

drylin®

Linear technology,

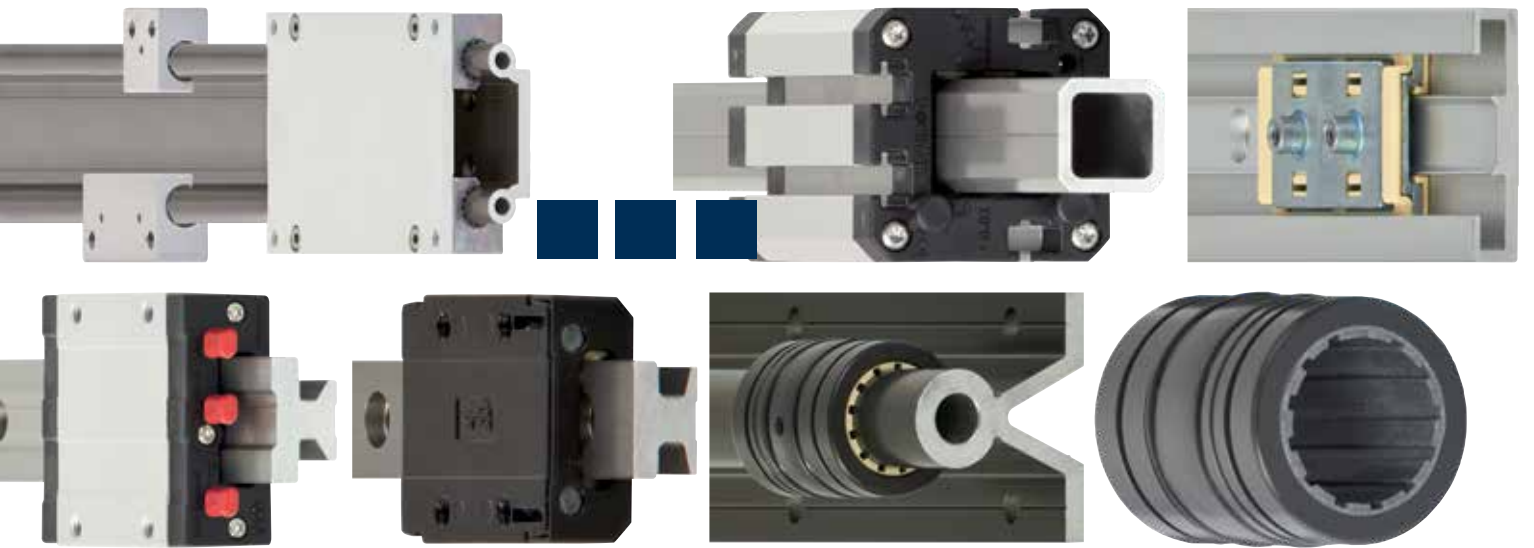

...plastics

drylin® linear technology | Application examples

Improve technology ... Reduce cost.

igus® produces innovative products with the goal of reducing maintenance, increasing lifetime and offering low-cost solutions for your equipment.



Label feeding system/Packaging technology

Quick and flexible format adjustment without external lubrication at lower costs using the drylin® T linear guide system.

drylin® linear technology | Application examples



CHAMPAGNE-BOTTLE SEALING MACHINE

With no required external lubrication and high chemical resistance, drylin® guides perform well in food industry applications

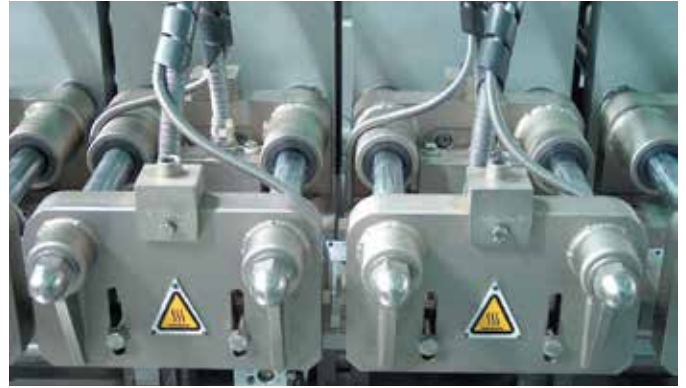

FORMING, FILLING AND SEALING MACHINE

Self-lubricating drylin® high temperature bearings up to 248°F (120°C), are used in welding jam of this form, fill and seal machine



DOOR ADJUSTMENT

Smooth, low-noise operation, as well as significant cost advantages are obtained by using drylin® W hybrid rolling bearings to guide the guards of machine tools



SYSTEMS FOR THE PRODUCTION OF ALUMINUM CARTRIDGES

The lack of external lubricants and the resistance to paint mist led to the use of drylin® R linear plain bearings

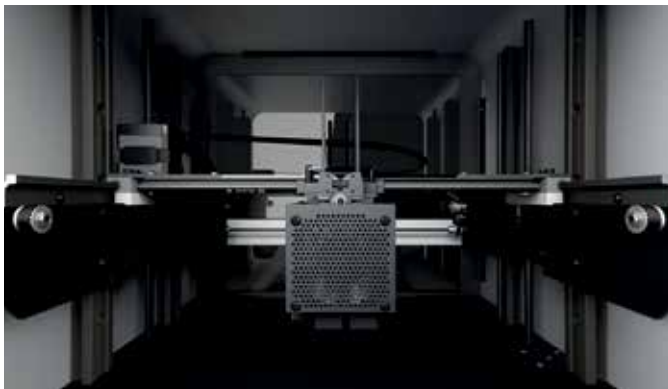

3D-PRINTER

drylin® T and W, as well as SD lead screw units travel without external lubrication, eliminating the risk of contaminating the housing, filament, and printed object in this 3D printer



MOBILE AND STATIONARY SAW MILLS

The drylin® W modular linear guide system with iglide® J liners smoothly adjust the saw blade guide of this mobile saw mill

drylin® linear technology | Product overview

drylin® W profile guides



Single rails, square:

WSQ-XX

▶ Page 1110



Pillow blocks, square:

Wj200QM

▶ Page 1111



Single rails, round:

WS-XX

▶ Page 1112



Single rails, round made of 316 stainless steel:

WS-XX-ES-(FG)

▶ Page 1113

drylin® W profile guides



With spring preload:

WJ(200)UM-XX-P

▶ Page 1117



Pillow blocks, single, round:

WJ200UMA-XX-AL

▶ Page 1118



Double rails square / round:

WSQ- / WS-XX-XX

▶ Page 1120 / 1126



High torsional rigidity: high profile rails

WSX-06 / WSX-10

▶ Page 1121 / 1127

drylin® W profile guides



Round double rail, made of 316 stainless steel:

WS-XX-XX-ES-(FG)

▶ Page 1128



Assembled stainless steel guide carriage, round:

WW-XX-XX-GESG-PES

▶ Page 1130



Curved rail profiles:

WSB

▶ Page 1132



Single bearings for curved rails:

WI3UBP-XX-LLZ

▶ Page 1134

drylin® W hybrid roller bearings



Single hybrid roller bearings:

WJRM-01

▶ Page 1146



Double hybrid roller bearings:

WJRM-21

▶ Page 1147



Hybrid single and double rollers, 316 stainless steel:

WRJM-XX-ES-FG

▶ Page 1148



Hybrid carriages for lateral installation:

WWR-21-XX

▶ Page 1149

drylin® linear technology - Accessories



Manual clamp for simple positioning:

WHKA-XX-(AL)/WHKAQ

▶ Page 1154



Manual clamp for higher holding force:

WHKD

▶ Page 1155



Manual clamp for drylin® W hybrid roller bearings:

WJRM-21-XX-HKA

▶ Page 1156



Liners made from dry-tech® polymers

▶ Page 1157

drylin® linear technology | Product overview



Pillow blocks, round:

WJ200UM

► Page 1114



Pillow blocks, round made of 316 stainless steel

WJUM-XX-ES-(FG)

► Page 1114



Tandem pillow blocks:

WJ200UMT-XX-AL

► Page 1115



Manual clearance adjustment:

WJ(200)UME

► Page 1116



Linear guides – lightweight, non-metallic:

WSPC

► Page 1122



Linear guides – lightweight, non-metallic:

WSPG

► Page 1123



Complete carriages: square/round

WWQ / WW

► Page 1124 / 1129



Mono-slide carriages:

WWC

► Page 1125



Carriages for curved rails:

WWB

► Page 1135



Double rails with machine recesses:

WS(Q)-XX-CAM

► Page 1136



Complete carriages for camera sliders:

WW-XX-SL

► Page 1137



Hybrid slider carriages with four double roller bearings:

WWH-XX-SL

► Page 1138



Hybrid carriages with four double roller bearings:

WWH-21

► Page 1150



Hybrid carriages for horizontal installation:

WWH-10

► Page 1151



Plastic liners:

J200UMA-XX

► Page 1158



End caps for drylin® high profile rails WSX:

WSX-XX-EC

► Page 1159

drylin® linear technology | Product overview

drylin® N low-profile linear guides



For small spaces:

Installation size 17

► Page 1168



The largest variety of carriages (options):

Installation size 27

► Page 1170



Suitable for aluminium construction profiles:

Installation size 40

► Page 1172



High loads with reduced height:

Installation size 80

► Page 1174

drylin® T guide rails and carriages



Guide rails:

► Page 1192



High performance series:

► Page 1195



Standard adjustable series

► Page 1193



Automatic clearance adjustment series:

► Page 1194

drylin® T rail guides



Accessories:

► Page 1199



Miniature guides:

► Page 1200



Adjustable miniature guides:

► Page 1201



Accessories:
End caps for guide rails and bores

► Page 1202

drylin® R liners made from iglide® J | inch / metric



Long, closed design for shafts:
JUI-01 / JUM-01

► Page 1214 / ► Page 1252



Long, open design for supported shafts:
JUIO-01 / JUMO-01

► Page 1215 / ► Page 1253



Long, closed design, low clearance:
JUI-11 / JUM-11

► Page 1216 / ► Page 1254



Works on all shafting

Long, open design, low clearance:
JUIO-11 / JUMO-11

► Page 1217 / ► Page 1255

... made from iglide® E7 | inch / metric



Long, closed design for shafts:
E7UI-01 / E7UM-01

► Page 1220 / ► Page 1260



Long, open design for supported shafts:
E7UIO-01 / E7UMO-01

► Page 1221 / ► Page 1261



Short, closed design for shafts:
E7UM-02

► Page 1262

Best match for steel and stainless shafting

drylin® linear technology | Product overview



Telescopic rails:

► Page 1180



Telescopic rails with detent:

► Page 1181



Accessories:
Manual clamp

► Page 1182



Accessories:
End cap

► Page 1183



With manual clamp:

► Page 1196



Heavy-duty version:

► Page 1197



Compact design:

► Page 1198



Accessories:

► Page 1199



Accessories:

Replacement plastic sliders

► Page 1202

... made from iglide® J200 | inch / metric



Short, closed design for shafts:
JUM-02

► Page 1256



Short, closed design low clearance:
JUM-12

► Page 1257



Long, closed design for shafts:
J200UI-01 / J200UM-01

► Page 1218 / ► Page 1258



Best match for aluminum shafts
Long, open design for shafts:
J200UIO-01 / J200UMO-01

► Page 1219 / ► Page 1259

... made from iglide® X | inch / metric



Long, closed design, high temperature:
XUI-01 / XUM-01

► Page 1222 / ► Page 1263



Long, open design, high temperature:
XUIO-01 / XUMO-01

► Page 1223 / ► Page 1264



For temperatures -148°F to 482°F and high chemical resistance
Short, closed design, high temperature:
XUM-02

► Page 1265

drylin® linear technology | Product overview

... made from iglide® A180 | metric

... made from iglide® A160 | metric



Long, closed design
for shafts:
A180UM-01

► Page 1266



FDA compliant

Long, open design
for supported shafts:
A180UMO-01

► Page 1267



Best match
for stainless
steel with FDA
compliant

Long, closed design
for shafts:
A160UM-01

► Page 1268

drylin® R all plastic bearings | inch / metric



Standard design
made from iglide®
RJI-01 / RJM-01

► Page 1224 / ► Page 1271



Standard design, precise,
made from iglide® J
RJIP-01 / RJMP-01

► Page 1225 / ► Page 1272



Japanese dimensions
made from iglide® J4
RJ4JP-01

► Page 1273



Low-cost
made from iglide® J260
RJ260UM-02

► Page 1274

drylin® R adapters | inch / metric



Closed, anodized
aluminum adapter
RE7UI-01 / RE7UM-01

► Page 1231 / ► Page 1282



Closed adapters made of
stainless steel 303
RJUI-ES / RJUM-ES

► Page 1233 / ► Page 1285



Split aluminum adapters
TJUI-01 / TJUM-01

► Page 1235 / ► Page 1286



Split aluminum adapters,
floating bearings
TJUI-03 / TJUM-03

► Page 1237 / ► Page 1287

drylin® R pillow blocks | inch



Closed pillow block
RJUI-XX

► Page 1246



Open pillow block
OJUI-XX

► Page 1247



Closed pillow block
Twin design
RJUI-XX-TW

► Page 1248



Open pillow block
Twin design
OJUI-XX-TW

► Page 1249

drylin® R shafts | inch



Aluminum shaft
AWI

► Page 1318



Supported aluminum
shaft
AWUI

► Page 1319



Steel shaft
SWI

► Page 1320



Supported steel shaft
SWUI

► Page 1321

drylin® linear technology | Product overview

drylin® R liners



Clip-on liners

JUCM

► Page 1270

Sliding disc



Sliding disc for large force displacement

RSDJ

► Page 1275

drylin® R adapters | inch / metric



Closed aluminum adapters

RJUI-01 / RJUM-01

► Page 1226 / ► Page 1276



Closed aluminum adapters, precise

RJUI-11 / RJUM-11

► Page 1227 / ► Page 1277



Closed aluminum adapters floating bearings

RJUI-03 / RJUM-03

► Page 1228 / ► Page 1278



Closed, anodized aluminum adapters, short design

RJUM-02

► Page 1279



Open, anodized aluminum adapters, for supported shafts

OJUI-01 / OJUM-01

► Page 1240 / ► Page 1288



Open aluminum adapters, floating bearing

OJUI-03 / OJUM-03

► Page 1242 / ► Page 1289



Closed, anodized aluminum adapters, short design

RE7UM-02

► Page 1283



Flanged pillow block Square

FJUI-XX

► Page 1250



Flanged pillow block Round, twin design

FJUIT

► Page 1250



Flanged pillow block Square, twin design

FJUI-XX-TW

► Page 1251



Stainless steel shafts

EWI - 440C

EEWI - 420C

► Page 1322



Stainless steel supported shaft

EWUI

► Page 1324

drylin® linear technology | Product overview

drylin® R pillow blocks | metric



Closed aluminum adapters, short design
RJUM-05

► Page 1290



Closed, adjustable aluminum adapters, short design
RJUME-05

► Page 1291



Split aluminum adapters, short design
TJUM-05

► Page 1292



Closed aluminum adapters, tandem design
RJUMT-05

► Page 1293

drylin® R pillow blocks | metric



Open aluminum adapters, long design
OJUM-06

► Page 1298



Open aluminum adapters, with manual clamp
OJUM-06-XX-HK

► Page 1299



Open, adjustable aluminum adapters, long design
OJUME-06

► Page 1300

drylin® R pillow blocks



Quad blocks, closed design
RQA

► Page 1306



Quad blocks, open design
OQA

► Page 1307



Closed tandem design
RTA

► Page 1308



Open tandem design
OTA

► Page 1309

drylin® R shafts | metric



Precision aluminum shafts
AWMP/AWMR

► Page 1328



Supported aluminum shafts
AWMU

► Page 1329



Steel shafts
SWM/SWMH

► Page 1330



Supported steel shafts
SWUM/SWUMN

► Page 1331

drylin® R shafts | metric



Low level partially supported stainless steel shafts
EWUMN-/EWUMSN-ES

► Page 1338



Carbon fiber shafts
CWM

► Page 1340

drylin® R shafts supports



Shaft end supports, floating
TA

► Page 1341



Shaft end supports, fixed
TAF

► Page 1342

drylin® linear technology | Product overview



Closed aluminum pillow block, long design
RJUM-06

► Page 1294



Closed aluminum pillow block, with manual clamp
RJUM-06-XX-HK

► Page 1295



Closed housings, floating bearings
RJUM-06-XX-LL

► Page 1296



Open housings, floating bearings
OJUM-06-XX-LL

► Page 1297

drylin® R flanged pillow blocks | inch / metric



Closed aluminum pillow block, round flange
FJUM-01

► Page 1301



Closed aluminum pillow block, square flange
FJUM-02

► Page 1302



Closed aluminum pillow block, round flange, tandem design
FJUIT-01 / FJUMT-01

► Page 1303



Closed aluminum pillow block, square flange, tandem design
FJUMT-02

► Page 1304



Closed, long design

RGA

► Page 1310



Open, long design

OGA

► Page 1311



Closed, short design

RGAS

► Page 1312



Open, short design

OGAS

► Page 1313



Stainless steel shafts
EWM/EEWM/EWMR

► Page 1332



Supported stainless steel shafts
EWUM

► Page 1334



Low level supported stainless steel shafts
EWUMN

► Page 1335



Partially supported stainless steel shafts
EWUM-ES/EWUMS-ES

► Page 1336



Shaft end blocks, standard design
WA

► Page 1343



Shaft end blocks, compact design
WAC

► Page 1344



Shaft end block, narrow design
WAS

► Page 1345



Flange shaft support
WAF

► Page 1346

drylin® linear technology | Product overview

drylin® Q square linear guides



Square section linear rails

AWMQ

► Page 1352



Adjustable linear carriages

QWE-01

► Page 1353



Adjustable linear carriages with manual clamp

QWE-01-XX-HKA

► Page 1354



Pillow blocks

QJRM(T)-05

► Page 1355

drylin® stop-motion preloaded linear guides



Prism rails

NSV

► Page 1362 / Page 1364



Preload prism slide, standard design

NWV-21-27-35

► Page 1363



Preload prism slide, long design

NWV-21-27-60

► Page 1365



Pillow blocks, round, with spring preload

WJ200UM-01-XX-P40

► Page 1366

drylin® digital measuring systems



Integrated measuring systems for drylin® Q

QKM

► Page 1376



Ready-to-install measuring systems for drylin® SLW linear modules

SLWM

► Page 1377



Digital measuring system for drylin® W

WKM2

► Page 1378



Measuring system with positionable readout display for drylin® W

WKMEDR

► Page 1379



**Fixed flange bearings
with round flange:**
QJFM(T)-01

► Page 1356



**Fixed flange bearings
with square flange:**
QJFM(T)-02

► Page 1356



**Solid plastic
linear bearings**
QJRMP-01

► Page 1357



**Accessories
for drylin® Q**

► Page 1358



**Measuring systems
with rail scale**
NKV-27-MES

► Page 1368



**Prism module for precise
adjustment**
SLNV

► Page 1369



**Telescopic rails
with locking mechanism**
NT-LM-35

► Page 1370



**Measuring systems for external
data output for drylin® W**
WKMEEX

► Page 1380

drylin® linear technology | Product overview

drylin® carbon fiber



Extremely lightweight linear guides
WSPC, WWPL

► Page 1386



Non-metallic toothed belt axis
ZLW-XX-P

► Page 1387



Linear module with carbon fibre high profile
SAW-XX-P

► Page 1388



Linear module with carbon fibre hollow shaft
SHTP-XX-CWM

► Page 1389

drylin® stainless steel



Closed, inch stainless steel (303) adapters
RJUI-01-ESR

► Page 1393



Closed, metric stainless steel (303) adapters
RJUM-XX-ES

► Page 1395



Stainless steel guides, single/double rails
WS-XX-ES-FG

► Page 1396



Pillow blocks, made from 316 stainless steel
WJUM-XX-ES-FG

► Page 1397

drylin® stainless steel



Low level supported stainless steel shafts
EWUMN

► Page 1409



Partially supported stainless steel shafts
EWUM-ES/EWUMS-ES

► Page 1410



Low level partially supported stainless steel shafts
EWUMN

► Page 1412



Stainless steel linear modules
SHT-ESJ

► Page 1414



**Carbon fiber
hollow shafts**
CWM

► Page 1390



**Hybrid roller bearings made
of stainless steel**
WJRM-01/WJRM-21

► Page 1398



**Assembled stainless steel
guide carriages, round**
WW-XX-GESG-PES

► Page 1400



**Stainless steel
shafts**
EWM/EEWM/EWMR

► Page 1402



**Supported stainless steel
shafts**
EWUM

► Page 1404

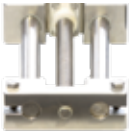

**“Hygienic design”
linear module**
SHTC-XX-HYD

► Page 1415



**Stainless steel linear
modules**
SLW-ES

► Page 1416



**XY-tables
Stainless steel version**
SLW-XY-ES

► Page 1417



Reverse modular axes
ZLW-20

► Page 1418

Self-lubricating drylin® linear guides

drylin® is a product range of self-lubricating linear plain bearings based on the principle of sliding instead of rolling. Tribologically optimized iglide® high-performance polymers are used as sliding surfaces. The drylin® linear systems use dry operation and are maintenance-free.

Besides the freedom from maintenance and external lubrication, the ruggedness and insensitivity to influences such as dirt, water, chemicals, heat or impacts, makes them ideal in many applications.

- Self-lubricating and resistant to dust and dirt
- High static load capacity
- Light, quiet and clean
- Durable and cost-effective

Typical application areas

- Lab and medical equipment
- On-board marine, aircraft, and automotive
- Kiosks
- Automation and robotics
- Packaging machinery
- Furniture

Available from stock

 Detailed information about delivery time online.

Price breaks online

 No minimum order value. No minimum order quantity.

Service life calculation

 www.igus.com/drylin-expert



Superior operating properties by combining iglide® bearing elements and anodized rails with round shaft profiles



Corrosion-resistant with anodized running surface



Quiet operation



Profiles available in various geometries, installation sizes and clearances



Clean with no lubricants required



Lightweight due to the use of plastics and aluminum

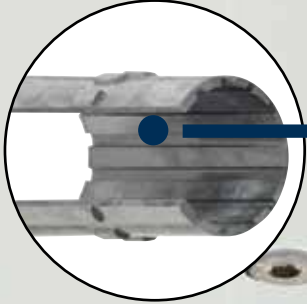

Maintenance-free due to integrated lubricants



Smooth operation with iglide® sliding elements



drylin® rail guides

drylin® W profile guides

- Highly flexible, modular systems with 14 different profiles and more than 50 carriage options
 - Versatile
 - Easy installation
- From page 1101

drylin® N low-profile linear guides

- Low profile installation heights from 6 to 12mm
 - Lightweight
 - Many carriage options – also with preload
- From page 1161

drylin® T rail guides

- Same dimensions as ball guide systems
 - Adjustable bearing clearance
 - Automatic clearance adjustment available
 - High static load capacity
- From page 1185

drylin® shaft guides

drylin® R shaft guides

- Same dimensions as recirculating ball bearings
 - For all shaft materials
 - Lightweight
 - Replaceable liners
- From page 1203

drylin® Q square linear guides

- Self-lubricating, torque-resistant square linear guides
 - Lightweight profiles made from hard-anodized aluminum
 - Manual adjustable carriages with/without manual clamp
 - Numerous fastening options
- From page 1349

Stop motion linear guides

► From page 1359

Measuring systems

► From page 1371

Carbon fiber

► From page 1383

Stainless steel

► From page 1391

drylin® linear technology | Slides instead of rolling!

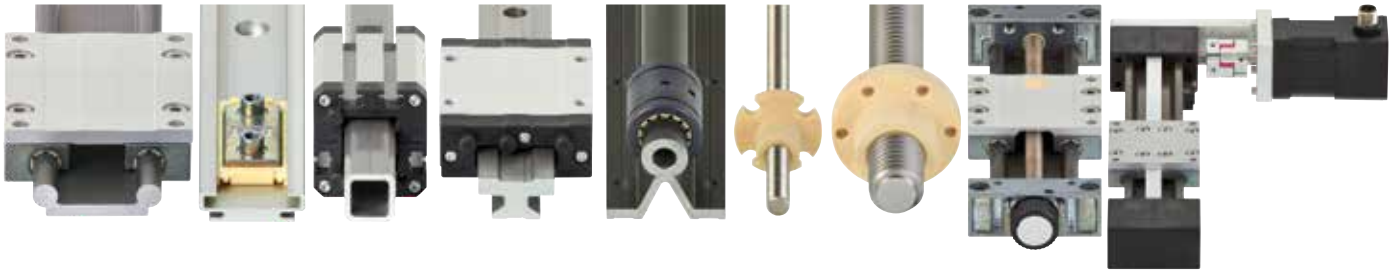

- Maintenance-free
- Wear-resistant
- Resistant to impacts and vibrations
- Corrosion-free
- Resistant to dirt, dust and humidity
- Low coefficient of friction
- Weight reduction
- Dry operation

- Suited for short-stroke applications
- High static load capacity
- High speeds and accelerations possible
- Self-lubricating
- Extremely quiet operation
- Low magnetism

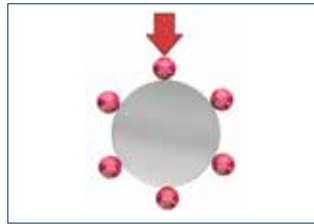
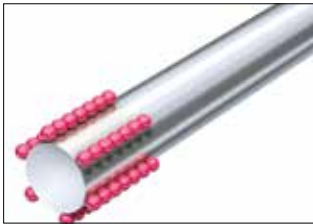

Rolling bearings – Point contact

Optimum load distribution

drylin® linear plain bearings operate on sliding elements unlike the traditional recirculating ball bearing systems. This gives a larger contact surface resulting in lower surface pressure. This leads to advantages which include:

- The use of non-hardened shafts
- The use of non-metallic shafts
- Scratching and shaft damage is completely excluded



Plain bearings – Surface contact

Shafts and rail materials

The large surface area of drylin® linear plain bearings, when compared to traditional ball bearings, means that under a given load the bearing pressure is greatly reduced. This allows soft shaft materials to be used, including hard-anodized aluminum, which in turn gives additional benefits in friction and wear rate values, carbon fiber shafts, which offer the lightest option and stainless steel for the highest chemical resistance. Hardened steel and stainless steel shafts as well as hard-chromed shafts can also be used with drylin® linear bearings.



Resistant to dirt, dust and moisture – By lubrication free insert and dirt channels.

Dry operation, without lubrication

drylin® linear bearing systems are designed for dry operation. As there is no grease or oil present, the application tends to naturally self clean, any particles are wiped away from the sliding surface by the ribbed design of the drylin® polymer bearing. This works well in coarse dirt or even sand. Particles are repelled from the contact surface by the movement itself. Here the front of the sliders works like a wiper. The contact surface remains clean.

drylin® linear technology | Slides instead of rolling!

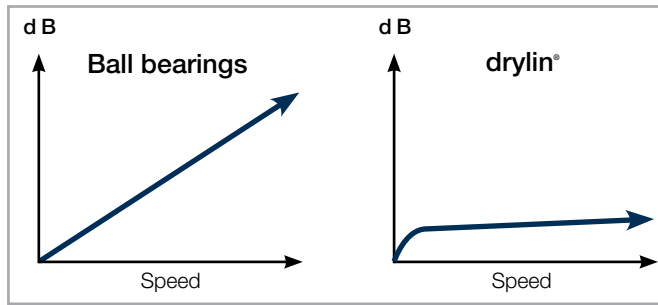
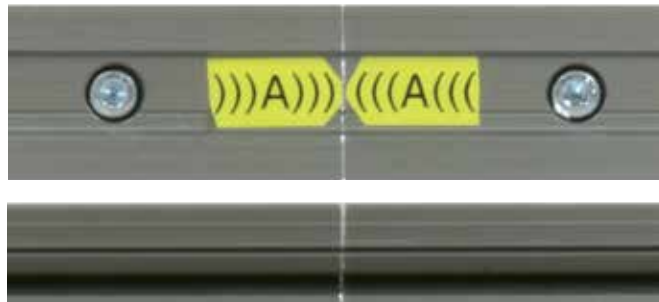

Figure 01: Comparison of noise development



Track joint



Thermal conductivity	[W / m · K]
Aluminum	235
Unalloyed steel	48–58
High-alloyed steel	15

Table 01: Thermal conductivity

Average surface speed

= Travel distance per cycle [m] / total cycle time [sec].

Quiet

The quiet operation is also a benefit of sliding rather than rolling. There are no loud collisions between a hard steel ball and the shaft or rail. The sliding motion is extremely quiet and only a light friction noise is audible.

Maximum stroke lengths

The joining or butting-up of multiple rails is easy with drylin®. The guide rails are slightly chamfered, aligned and simply mounted against each other. The joint can be passed over by the sliding element without problems. Assembly is simplified by the distinctive joint marking provided at the factory.

Permitted speeds/acceleration

drylin® linear plain bearings slide instead of roll. This makes the bearing independent of the mass inertia of this body and can be used with high speeds up to 10m/s and accelerations up to 100g.

drylin® linear bearings are especially suitable for applications with light loads with high speeds. The use of hard-anodized aluminum guide rails lowers the operating temperature in the bearing due to the high thermal conductivity of aluminum. This is an advantage with very short stroke application.

The maximum average surface speed results from the load on the bearings. With decreasing surface load, higher speeds can be achieved. More important than the maximum speed reached is the average speed over a period of time, because this has the most influence on the heating of the bearing system. In cases with breaks between the individual cycles, the maximum average surface speed is / critical, which is achieved during a period of 10 to 30 minutes.

drylin® linear technology | Slides instead of rolling!



Extreme application conditions in the offshore industry



Filling machine, Krones AG, Rosenheim



The iglide® X material in heavy-duty use under high temperatures in foundries



Self-lubricating and resistant to dirt

Corrosion resistance

The low humidity absorption of drylin® bearings and liners permit their use for underwater applications. The use of stainless steel or anodized aluminum shafts provides for a corrosion-resistant shaft partner. Anodized aluminum is resistant to neutral chemical substances, with a pH between 2 and 7. For special applications separate tests are recommended.

Chemical resistance

iglide® J is resistant to weak acids, diluted alkalis as well as to fuels and all types of lubricants. The intensive cleaning of machines with standard commercial cleaning agents, even in the food industry, is no problem for drylin® guides. For applications in environments with more aggressive cleaning agents, the use of the drylin® R or W bearings with iglide® X liners is recommended. The resistance of linear bearing systems is equally dependent on the shaft or rail material. For the highest resistance to chemicals, a 304 or 316 stainless shaft material is optimal.

Operating temperatures

Sliding elements made from iglide® J and J200 can be used in the temperature range between -58°F and +194°F (-50 and +90°C). In applications with aluminum shafts or rails, distinctly higher loads and speeds can be attained due to the excellent thermal conductivity. Sliding elements made of iglide® X can be used in temperatures ranging from -148°F to 482°F (-100°C to +250°C).







Resistance to dirt

Applications exposed to coarse dirt and sand are possible since debris is wiped away by the sliding of the plain bearing. The lack of required external lubrication means that seals are not required as there is no grease or oil to attract dust and dirt.

Hard anodized surfaces

For drylin® systems using iglide® J or J200 hard anodized shafts have optimized wear properties, high chemical resistance, and a high degree of hardness. Color alterations and slight crazing of the anodized surface may occur, but do not alter the wear resistance, corrosion resistance, or bearing properties. Cut surfaces will not be coated. If this is required please contact igus®.

drylin® linear technology | Slides instead of rolling!

	 The All-rounder – iglide® J	 The specialist – iglide® J200	 The extreme – iglide® X	 The endurance runner – iglide® E7	 The FDA-compliant – iglide® A180	 Blue Sky Thinking FDA/EU-compliant – iglide® A160
Application temperature	from -58°F to +194°F (-50°C to +90°C)	from -58°F to +194°F (-50°C to +90°C)	from -148°F to +482°F (-100°C to +250°C)	from -58°F to +158°F (-50°C to +70°C)	from -58°F to +194°F (-50°C to +90°C)	from -58°F to +194°F (-50°C to +90°C)
Best coefficient of friction with	Steel shaft	Hard-anodized aluminum	Hard-chromed steel	Steel/stainless steel shaft	Stainless steel shaft	Hardened stainless steel shafts
Volume resistance	> 10 ¹³ Ωcm	> 10 ⁹ Ωcm	< 10 ⁹ Ωcm	> 10 ⁹ Ωcm	> 10 ¹² Ωcm	> 10 ¹² Ωcm
Moisture absorption	1.3% weight	0.7% weight	0.5% weight	< 0.1% weight	0.2% weight	< 0.1% weight
Maximum service life with	Hard-anodized aluminum	Hard-anodized aluminum	Hardened stainless steel	Steel/stainless steel shaft	Stainless steel shaft	Hardened stainless steel shafts
Potential counter partner	All shaft materials	Hard-anodized aluminum	Hardened stainless steel	Steel/stainless steel shaft	All shaft materials	Stainless steel
Permissible stat. surface pressure	5,076 psi	3,336 psi	21,760 psi	2,611 psi	4,061 psi	2,176 psi
Part No.	JUI /JUM-...	J200UI / J200UM-...	XUI / XUM-...	E7UI / E7UM-...	A180UM-...	A160UM-...

Ideal material combinations

iglide® J:

- Maintenance-free, dry running
- Low coefficients of friction with all materials
- Excellent wear resistance
- Very low humidity absorption
- ▶ More about iglide® J ▶ [Page 193](#)

iglide® J200:

- Completely maintenance-free
- Extremely high service life on hard-anodized aluminum
- Low coefficients of friction with hard-anodized aluminum
- Excellent wear resistance with anodized aluminum
- ▶ More about iglide® J200 ▶ [Page 321](#)

iglide® X:

- Completely maintenance-free
- Temperature resistance -148°F to 482°F (-100°C to +250°C) in continuous operation
- Universal resistance to chemicals
- Very low humidity absorption
- ▶ More about iglide® X ▶ [Page 339](#)

Other possible materials:

iglide® A180 FDA-compliant

- ▶ More about iglide® A180 ▶ [Page 493](#)

iglide A160 FDA-compliant

- ▶ More about iglide® A160 ▶ [Page 515](#)

iglide® E7, steel and stainless shaft specialist

- ▶ More information about iglide® E7 ▶ [Page 327](#)

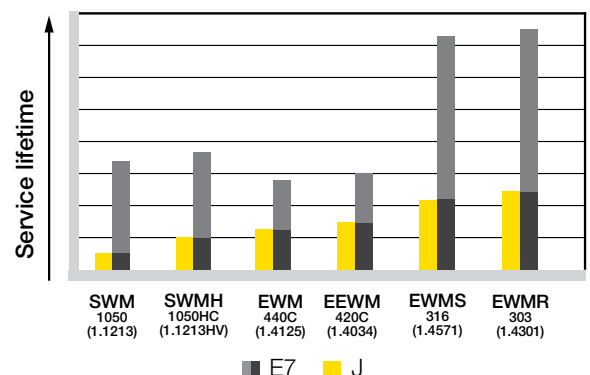
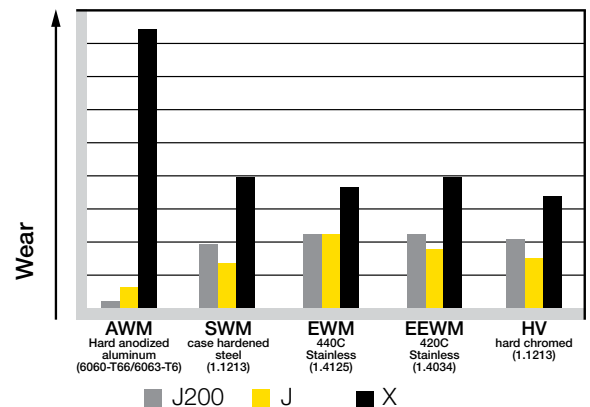
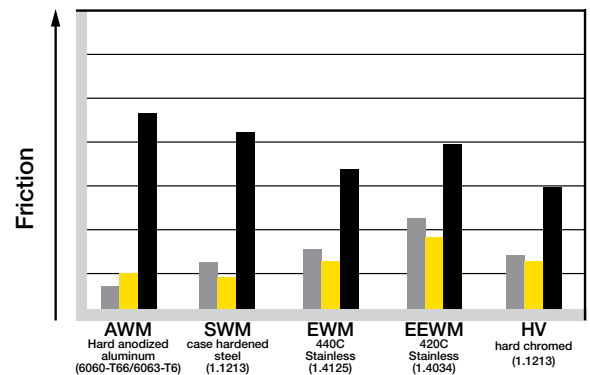

drylin® linear technology | Product selection

	Sizes	Self-lubricating and quiet operation	Dimensionally interchangeable with recirculating ball bearings	Profile rails	Shafts	Square profiles	Single pillow block	Complete carriage	Hybrid roller bearing
drylin® W	5	●		●			●	●	●
drylin® N	4	●		●				●	
drylin® Q	3	●				●	●	●	
drylin® T	4	●	●	●				●	
drylin® T mini	4	●	●	●				●	
drylin® R	12	●	●		●		●		

	Loads > 100 kg	High durability under shock loads	Resistant to dirt	Compact, space-saving	Particularly light weight	Torque-resistant	Torsionally stable	Unsupported installation
drylin® W	+	+	++	+	+	+	++	+
drylin® N			+	++	++	+		
drylin® Q			+	+	+	++	+	++
drylin® T	+	+	+			+	+	
drylin® T mini			+	++	++	+		
drylin® R	++	++	++					+

	Manual adjustable bearing clearance	Automatic adjustable bearing clearance	Automatic preload	Floating bearing function	Manual clamp	with measuring system	with lead screw drive	with toothed belt drive
drylin® W	+			+	+	+	+	+
drylin® N			++	+	+		+	
drylin® Q	+				+	+		
drylin® T	+	+		+	+			
drylin® T mini	+			+			+	
drylin® R				+			+	

	Stainless steel components	Temperatures above +194°F	Chemical-resistant	FDA-compliant	Cleanroom and ESD	Door/control panel adjustments	Camera slider	3D-print components
drylin® W	++	++	++	++	+	++	++	++
drylin® N		+			+	+	+	++
drylin® Q					+			
drylin® T		+			++			
drylin® T mini					+	+		++
drylin® R	++	++	++	++	+			++

⊕ suitable ⊕⊕ particularly suitable

Aluminum profiles

Aluminum, extruded section according to EN AW 6061/6060/6063

Shafts and rail profiles

Surfaces

drylin® W, drylin® T¹⁵⁵, drylin® R, drylin® Q

hard-anodized, bare surface

drylin® N, profile with CA marking

clear-anodized, bare surface

drylin® N, profile with AR marking

black-anodized (anti-reflect), bare surface

¹⁵⁵ Exception: TS-11-20 clear-anodized

Profile straightness tolerances

Shafts AWI

0.004"/ft

Shafts AWMP / AWMR

DIN 754-3; 2mm/m, local 0.6mm/300mm

DIN EN 12020-2

Profile rails AWMU / AWMQ, WS / NS / TS

Total length up to 1,000mm; Straightness 0.7mm

Total length up to 2,000mm; Straightness 1.3mm

Total length up to 3,000mm; Straightness 1.8mm

Total length up to 4,000mm; Straightness 2.2mm

drylin® linear technology | Curved rails and profiles

drylin® curved linear guide profiles

igus® provides standard and customized curved rails for the drylin® W product range. This is especially for the requirements in operating ergonomics, such as guiding monitors and control systems in a radius to ensure safe and easy accessibility.

- Self-lubricating drylin® W carriages for curved rails ► **Page 1135**
- Variable profile directions
- Torque-resistant alternative to curved tube profiles
- Bending option depending on the radius, rail length, bearing/carriage and mounting
- Customized project service

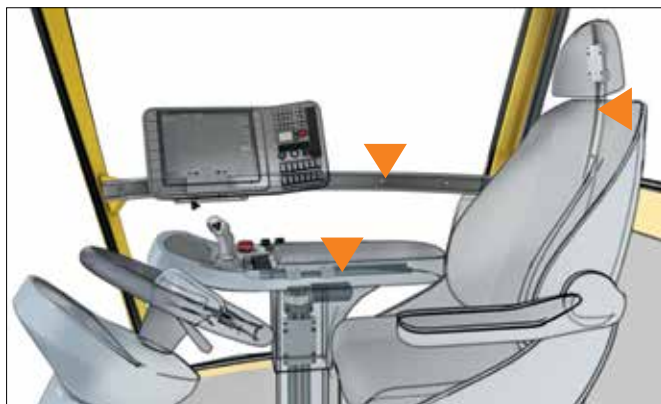

Curved drylin® linear technology – for ergonomic operation and optimal field of view

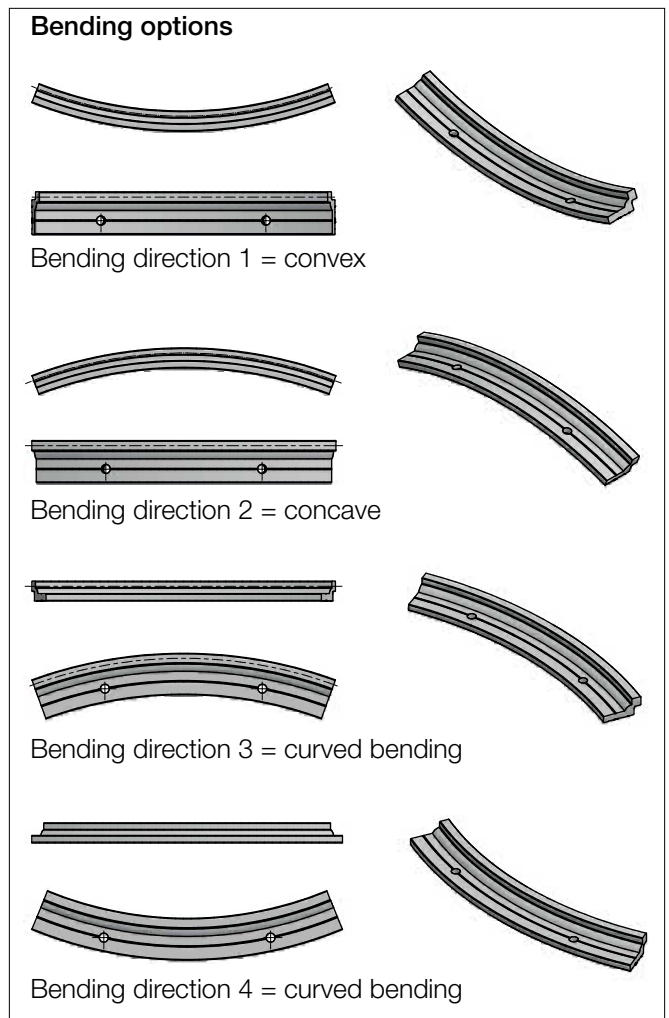

Different radii and bending directions available upon request

 More Information and checklist online
► www.igus.com/drylin/linear-guide

Fixed and Floating Bearing Mounting Instructions

When using systems with 2 parallel rails, one side must be designated as the “fixed” rail, and the opposite side as the “floating” rail.

Why use floating bearings?

- promotes smooth gliding performance and maximizes bearing life
- prevents binding caused by parallelism and angle errors
- decreases necessary drive force and wear by minimizing friction-forces
- Enhances the precision of the system over the bearings' lifetime.
- Reduce assembly time and cost

Fixed Bearings

The “fixed” bearing rail should be positioned closest to the drive force. This rail will determine the precision of the system; no system should contain more than two “fixed” bearings.

Floating/Self-Aligning Bearings

The “floating” rail should be the rail located furthest from the drive force. It is to act only as a guide, and will compensate for any misalignments or angle errors in the system ensuring proper functionality.

Mounting Surfaces

The mounting surfaces for rails and bearings should have a very flat surface (e.g milled surface) in order to enhance performance. Variations in these surfaces may be compensated for by using floating bearings.

Eccentric Forces

The 2:1 Rule

When using linear plain bearings it is important to ensure that the acting forces follow the 2:1 Rule (see drawing). If either the load or the drive force (F) is greater than twice the bearing length (1X), then a binding or interrupted motion may occur.

If the location of the drive force or load cannot be changed, simply increase the distance between the bearings, or create a counterbalance to move the center-of-gravity back within the 2 to 1 ratio.

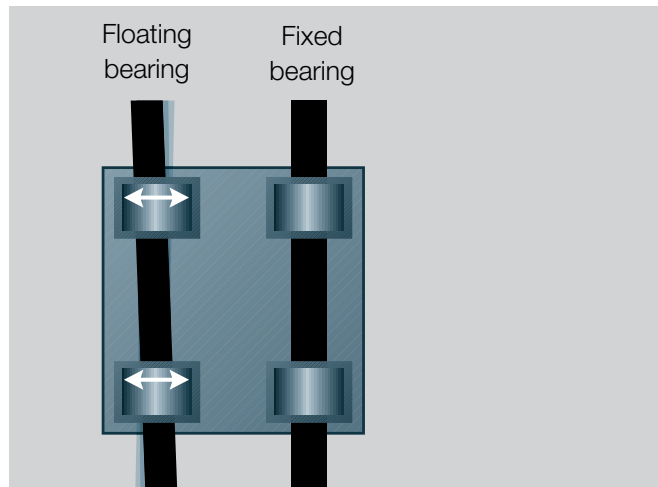

Figure 02: Automatic compensation of parallelism errors

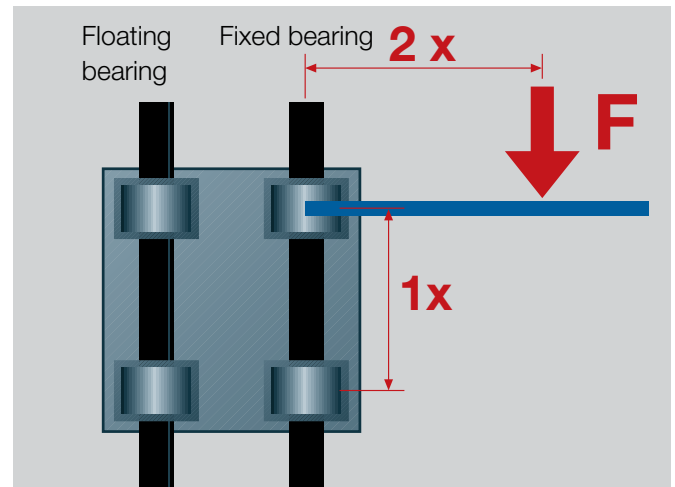

Figure 03: The 2:1 rule

Tightening torque for drylin® metallic screws

Metric thread (Da)	Tightening torque [Nm]	Recommended tightening torque [Nm]
M3	0.5 – 1.1	0.7
M4	1.0 – 2.8	1.5
M5	2.0 – 5.5	3.0
M6	4.0 – 10.0	6.0
M8	8.0 – 23.0	15.0
M10	22.0 – 46.0	30.0

Please be aware of the minimal screw-in depth for aluminum and zinc die-casting parts: 1.5 x Da

Cleanroom suitability and ESD compatibility of drylin®

drylin® linear guides by igus®

All drylin® guide systems are clearly qualified for clean room applications. The differentiation between the various clean room classes is only dependent on load and speed of the application. The combination of iglide® J and hard anodized aluminum is classified as level 1 in the ESD compatibility according to SEMI E78-0998 (Highest rank).

The following drylin® guides from igus® were tested: N40, W10, T25 and T30.

See below for detailed results.

Linear guide system drylin® TK-10-30-01

"For the linear guide system drylin® TK-10-30-01 by igus® GmbH, it is possible, on the calculations of the likelihood of violation of threshold values of the detection sizes 0.2 µm, 0.3 µm, 0.5 µm, and 5 µm with motion speed of $v = 0.1$ m/s, to clearly derive suitability for clean rooms classified as ISO Class 3 according to DIN EN ISO 14644-1."

Linear guide system drylin® NK-02-40-02

"For the linear guide system drylin® NK-02-40-02 by igus® GmbH, it is possible, on the calculations of the likelihood of violation of threshold values of the detection sizes 0.2 µm, 0.3 µm, 0.5 µm, and 5 µm with motion speed of $v = 1$ m/s, to clearly derive suitability for clean rooms classified as ISO Class 6 according to DIN EN ISO 14644-1."

The measurement results of the ESD compatibility according to SEMI E78-0998 show that the linear guide system drylin® NK-02-40-02 can be classified as "level 1" (Highest rank). See Fraunhofer IPA Report No.: IG 0308-295 73.



Linear guide system drylin® TK-01-25-02

"For the linear guide system drylin® TK-01-25-02 by igus® GmbH, it is possible, on the calculations of the likelihood of violation of threshold values of the detection sizes 0.2 µm, 0.3 µm, 0.5 µm, and 5 µm with motion speed of $v = 1$ m/s, to clearly derive suitability for clean rooms classified as ISO Class 5 according to DIN EN ISO 14644-1."

The measurement results of the ESD compatibility according to SEMI E78-0998 show that the linear guide system drylin® TK-01-25-02 can be classified as "level 1" (Highest rank).

Linear guide system drylin® WK-10-40-15-01

"For the linear guide system drylin® WK-10-40-15-01 by igus® GmbH, it is possible, on the calculations of the likelihood of violation of threshold values of the detection sizes 0.2 µm, 0.3 µm, 0.5 µm, and 5 µm with motion speed of $v = 1$ m/s, to clearly derive suitability for clean rooms classified as ISO Class 6 according to DIN EN ISO 14644-1."

The measurement results of the ESD compatibility according to SEMI E78-0998 show that the linear guide system drylin® WK-10-40-15-01 can be classified as "level 1" (Highest rank).

See Fraunhofer IPA Report No.: IG 0308-295 74.

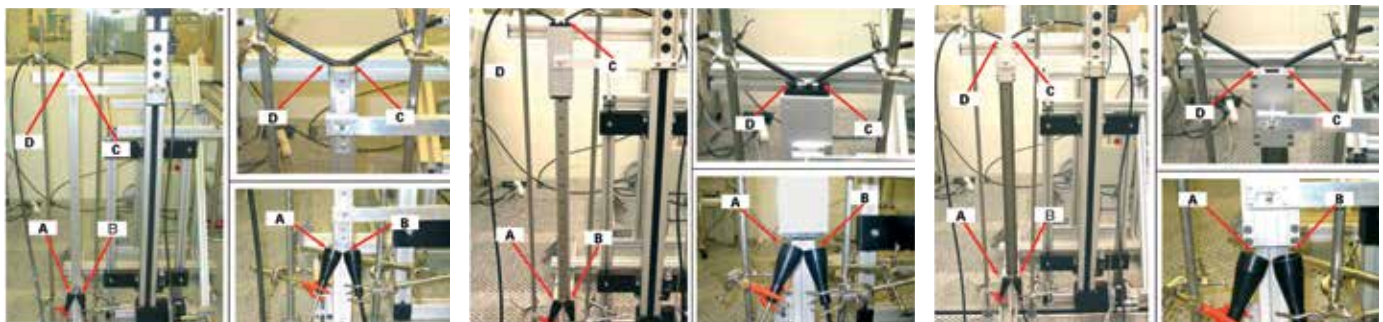

drylin® linear guides expert

With the drylin® linear guides expert, you can configure a linear guide to suit your particular application and, at the same time, calculate its service life. After this, you can simply order your configuration online or request further information.

Select series

 <p>drylin® T Profile guide rail system</p> <ul style="list-style-type: none"> Max. load capacity up to 14,000 N Strokes from 17 mm to 30 mm Installation dimensions from 8 mm to 42 mm Temperatures from -40°C to 90°C Adjustable clearance <p>Select</p>	 <p>drylin® N Low-profile guide</p> <ul style="list-style-type: none"> Max. load capacity up to 1,000 N Strokes from 17 mm to 80 mm Installation dimensions from 8 mm to 32 mm Temperatures from -40°C to 90°C Low weight <p>Select</p>	 <p>drylin® W Modular guide system kit</p> <ul style="list-style-type: none"> Max. load capacity up to 12,800 N Temperatures from -40°C to 90°C Quick and easy assembly Insensitive to dust & dirt Low installation height Easy installation <p>Select</p>
 <p>drylin® R Shaft guide</p> <ul style="list-style-type: none"> Max. load capacity up to 70,000 N Diameters from 8 mm to 50 mm Temperatures from -100°C to 250°C Round and tapered shafts 8 shaft materials Replaceable with ball bearings <p>Select</p>		

Expert for linear guides: System selection and service life calculation with CAD

Configure linear bearings and calculate their service life – constantly expanded by new sizes and products

Easily calculate the service life of your required linear guide and configure with a few clicks. Select a drylin® system and add the relevant environmental parameters. Select the bearing size, carriage, number and position. Then enter the distance between the rails and the mounting. Define more relevant parameter of the guidance and select a rail length. The results are displayed.



► www.igus.com/drylin-expert



Download the online tool app now



igus® plastics for longer life®

Search: _____

igus® CAD | Download center | My Products | Contact | Help

Product groups

- igus® CAD
- Energy Chain®
- igus® 3D printing service
- igus® PBT
- igus® bearings
- igus® spherical bearings
- igus® ball bearings
- DryLin® linear bearings**
 - W - Profile Linear Guide
 - N - Accessories & Shafts
 - DryLin® TAJUR CAD configurator
 - DryLin® Round Slide
 - E - drive technology
 - Screw drives
 - N - Low Profile Linear Guide System
 - Q - Linear square guide
 - R - Linear Flange Bearings
 - SH - Linear Slide Table
 - SUH - Spherical linear module
 - T - Linear slide guides

W-Profile Linear Guide | N-Accessories & Shafts | DryLin® TAJUR CAD configurator | DryLin® Round Slide | E-drive technology | SHW - Digital measuring system | SAW - light weight extension arm | ZUH - Ball Drive

drylin® CAD configurator: Generate complete 3D models for drylin® linear technology according to your specifications

The igus® CAD online configurator gives you the ability to design and save your linear guide as a system, individual components directly as a 3D model in all commonly used formats, or to have these sent by e-mail – free of charge and without registration.



► www.igus.com/drylin-CAD

Products | Service | Shopping Cart (0) | Order list | Company | Press | Fairs

Home > Downloads

Downloads

You have access to the latest downloads here. Left-click on the software symbol to display the file. Right-click on the software symbol to download the file.

Request and order brochures and catalogues

Download by categories

Catalogue
 Industry newsletters
 Certificates
 Product selection
 Industry sector
 Languages
 Search terms

Brochures
 Software
 Data sheets
 Assembly instructions
 News & notices
 All

English
 Polish
 Chinese
 Russian
 French
 Spanish
 German

igus® GmbH
 Spicher Str. 1a
 51147 Cologne
 Germany
 igus® contact
 if +49 (0) 2233-0440-0
 Send e-mail to igus®
 myigus
 myCatalog
 No minimum order value
 24h 365d Delivery-Consultation
 Free samples
 Is something not to your liking?
 Feedback
 More than 100,000 products available!
 Delivery and consultation
 Mon-Fri from 7am-6pm
 and Sat from 9am-12pm
 Newsletter Registration

More information about the products can be found in the igus® download area

- Assembly instructions
- Assembly videos
- System design
- Catalogs



► www.igus.com/downloads

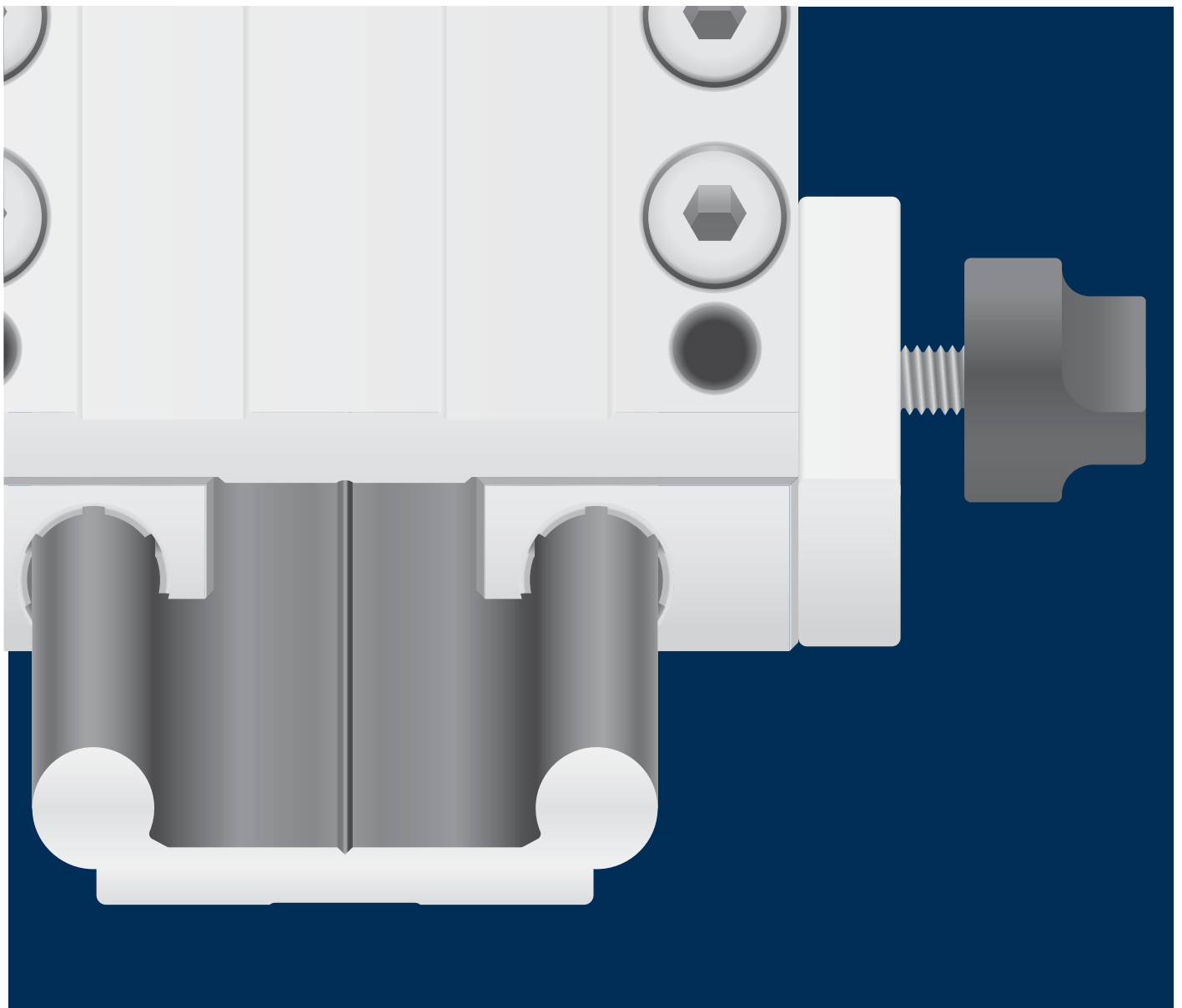

drylin® linear technology – drylin® W profile guides

Modular linear guides

Replaceable self-lubricating drylin® liners

Robust linear housings

Ready-to-install linear carriages

Single and double rails



drylin® W profile guides | Advantages

Self-lubricating, light, quiet, long service life, cost effective

Tribologically-optimized systems with iglide plastic bearing liners and anodized aluminum profiles

Corrosion resistant

Quiet operation

Clean, no external lubrication is required

Lightweight through the use of plastics and aluminum

Low friction iglide® J200 and iglide® J performance plastics

Maintenance free

Profiles with various geometries, installation sizes and clearances

Self-lubricating linear system - drylin® W

drylin® W profile guides are a cost-effective pre-assembled system. The design allows extremely high flexibility in the construction and installation due to the use of individual or double rails. Hard-anodized aluminum is used as rail material and provides the best friction and wear results. The absence of lubrication makes the profile guide system extremely insensitive to dirt and, due to its cleanliness, it is also suitable for applications in clean and hygienic environments.

- Easy installation, maintenance-free
- Resistant to dirt thanks to dry operation
- Lightweight and quiet
- Square rail with floating bearing function for 90° installation
- Bearing with manual clearance adjustment available

Typical application areas

- Agricultural machinery
- Automotive
- Medical technology
- Packaging industry
- Furniture



Available from stock

Detailed information about delivery time online.



Price breaks online

No minimum order value. No minimum order quantity



max. +392°F (200°C) depending on material
min. -40°F (-40°C)



Carriage lengths: 60-250 mm
Carriage widths: 54-195 mm
Rail length: up to 4,000 mm



Online product finder

► www.igus.com/drylin-expert

drylin® W profile guides | Product overview

Profile guides for almost unlimited design freedom



Single components: single and double rails

- Material: aluminum, hard-anodized
- Design freedom
- 316 stainless steel rails

► From Page 1110



Individual components: Pillow blocks

- Material: Zinc die-casting, aluminum or stainless steel
- Round or square design
- Liners made from iglide® high-performance polymers

► From Page 1111



Assembled systems: Complete carriages

- Pre-assembled
- Variable lengths and widths
- One-piece monoslide available in aluminum

► From Page 1124



Hybrid guides

- Linear housing with integrated single or double roller
- Low drive force
- Available as single housing or complete carriage

► From Page 1139



Accessories

- Manual clamp for single bearing housing and complete carriages
- End caps for high profile rails

► From Page 1153

Based on drylin® W



Measuring systems

► From Page 1371



Linear modules

SLW/SAW/GRW/ZLW

► From Page 1581

drylin® W profile guides | Application examples



drylin® linear bearings enable precise positioning at high speeds, and do not require external lubrication like traditional bearings.

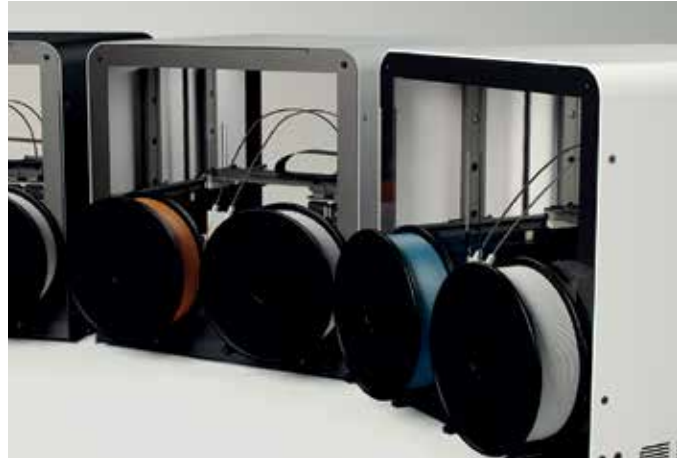

Low weight and quiet, precise movement, drylin® bearings are used in a number of 3D printing applications.

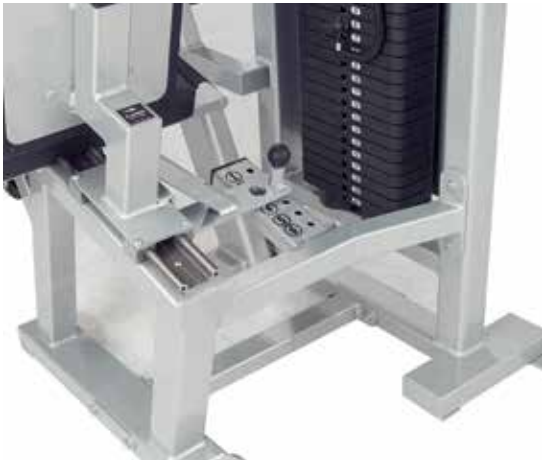

The adjustment mechanisms of fitness equipment require no maintenance when manufactured with drylin® profile guides.



drylin® W is used on this casting machine which is subject to high temperatures and debris



On this complex machine, the price advantage, coupled with resistance to dirt and dust were the customer's deciding factors for selecting drylin® W.



Stage technology's requirements for quiet, low-vibration adjustment are enabled through the use of steel drylin® W linear guide systems partnered with self-lubricating iglide® sliding elements.

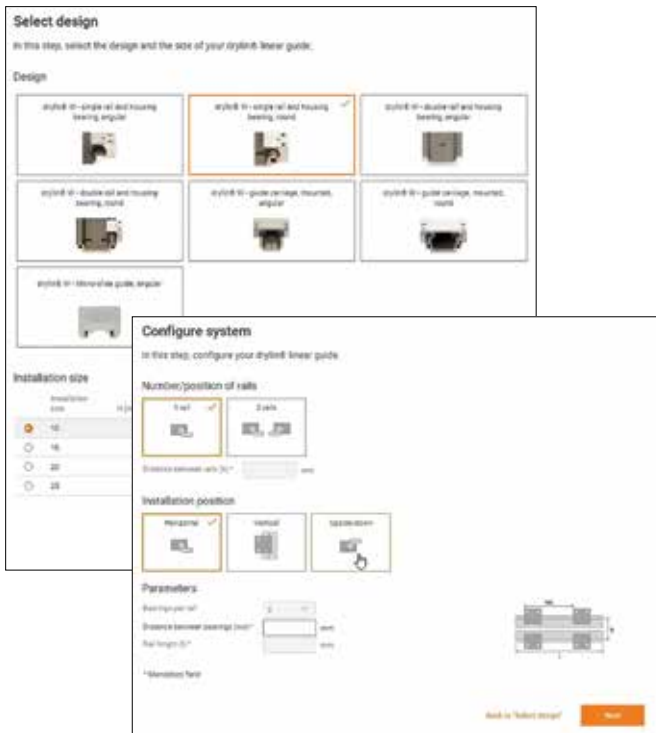

Expert for linear guides: System selection and service life calculation with CAD
 Configure and calculate the service life of linear bearings – constantly expanded by new sizes and products

Easily calculate the service life of your required linear guide and configure with a few clicks. Select a drylin® system and add the relevant environmental parameters. Select the bearing size, carriage, quantity and position. Then enter the distance between the rails and the mounting. Next, define more relevant parameters of the guidance and select the rail length. The results are then displayed.



► www.igus.com/drylin-expert



Download the online tool app now



drylin® CAD configurator: Generate complete 3D models for drylin® linear technology according to your specifications

The igus® CAD online configurator gives you the ability to design and save your linear guide as a system, as individual components directly as a 3D model in all commonly used formats, or to have these sent by e-mail – free of charge and without registration.



► www.igus.com/drylin-CAD



More information about the products can be found in the igus® download area

- Assembly instructions
- Assembly videos
- System design
- Catalogs



► www.igus.com/downloads



drylin® W profile guides | Product Selection

Subheading

Profiles	Installation size					Liners material				
	06	10	16	20	25	J	J200	X	A180	E7
Single rail, round		●	●	●	●	●	●	●	●	●
Single rail, square	●	●	●	●	●		●			
Double rail, round		●	●	●	●	●	●	●	●	●
Double rail, square	●	●	●	●			●			
High profile, round		●	●			●	●	●	●	●
High profile, square	●						●			
Stainless steel		●	●	●	●	●	●	●	●	●
Carbon fiber/fiberglass	●									
Curved rail	●	●								
Bearing housing – material										
Zinc die-cast	●	●	●	●	●	●	●	●	●	●
Aluminum	●	●	●	●	●	●	●	●	●	●
Stainless steel		●	●	●	●	●	●	●	●	●
Bearing housing – options										
With manual clamp	●	●	●	●	●	●	●	●	●	●
Clearance adjustment		●	●	●		●	●			
Hybrid roller bearing		●	●	●	●	●				
Pre-load		●	●	●						
Bearing can be changed on the rail		●					●			
Linear guides										
Pre-assembled carriages	●	●	●	●	●	●	●	●	●	●
Hybrid carriages		●	●	●		●				
Monoslide carriage	●	●	●	●		●				
Systems										
Lead screw modules	●	●	●	●	●	●	●	●	●	●
Toothed belt axis	●	●	●	●			●			
With measuring system		●				●				

- Standard
- Optional

drylin® W profile guides | Technical Data | Floating bearings

Subheading



Floating bearings for all directions compensate misalignments and parallelism errors

System Assembling: Rails

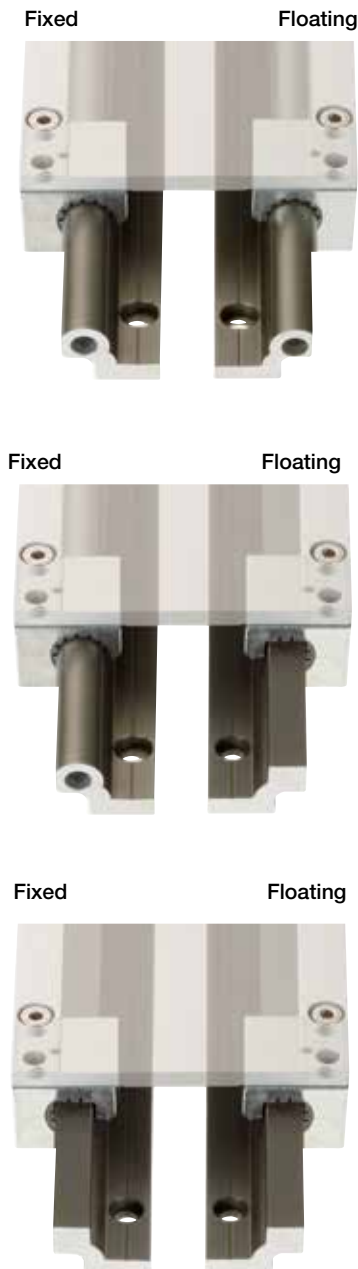

Floating bearings facilitate assembly – only necessary for individual rails.

Although drylin® W is a profile rail system, it is able to compensate angular rotation errors about the x-axis. An angular adjustment of $\pm 7^\circ$ is possible. This effectively eliminates the problems known to occur when fitting to sheet metal.

Assembly is made even easier with the drylin® WQ square profile. Floating bearings for all directions (± 1 mm) compensate for misalignments and parallelism errors between rails. Reduces time-consuming parallel alignment of the system.

Available floating bearing blocks

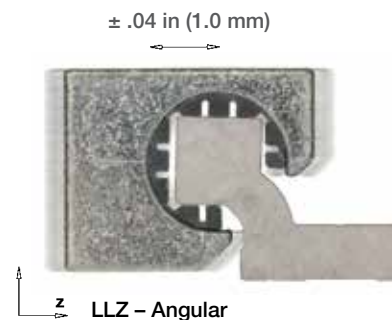
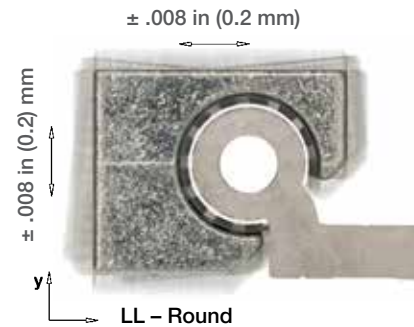

NOTE: Rail configuration not possible with WS-10 and WSQ-10, rail height is not equal



Self-lubricating iglide® high-performance polymers

Form-fit anti-rotation feature

Vibration-dampening

Low coefficient of friction, low wear

Corrosion-free

Form-fit locating spigot

Resistant to dirt

Integrated flute design for dirt to pass through

Open geometric design for rapid assembly

drylin® liners made from high-performance polymers

Extremely wear-resistant tribopolymers improved by precisely blended additions of strengthening materials and solid lubricants, tested a thousand times and proved a million times – that is iglide®. Further to the general properties, every iglide® bearing material has a series of special features, which account for its particular suitability for certain applications and requirements. The detailed description of the materials can be found in the respective sections.

- Self-lubricating
- Corrosion-free
- Low coefficient of friction
- Maintenance-free
- Dirt resistance
- Lightweight
- High wear resistance
- Excellent price-performance ratio



The All-rounder – iglide® J



The specialist – iglide® J200



The extreme – iglide® X



The endurance runner – iglide® E7



The FDA-compliant – iglide® A180



Blue Sky Thinking FDA/EU-compliant – iglide® A160

	The All-rounder – iglide® J	The specialist – iglide® J200	The extreme – iglide® X	The endurance runner – iglide® E7	The FDA-compliant – iglide® A180	Blue Sky Thinking FDA/EU-compliant – iglide® A160
Application temperature	from -58°F to +194°F	from -58°F to +194°F	from -148°F to +482°F	from -58°F to +158°F	from -58°F to +194°F	from -58°F to +194°F
Best coefficient of friction with	Steel shaft	Hard-anodized aluminum	Hard-chromed steel	Steel/stainless steel shaft	Stainless steel shaft	Hardened stainless steel shafts
Volume resistance	> 10 ¹⁰ Ωcm	> 10 ¹⁰ Ωcm	< 10 ¹⁰ Ωcm	> 10 ¹⁰ Ωcm	> 10 ¹⁰ Ωcm	> 10 ¹⁰ Ωcm
Moisture absorption	1.3% weight	0.7% weight	0.5% weight	< 0.1% weight	0.2% weight	< 0.1% weight
Maximum service life with	Hard-anodized aluminum	Hard-anodized aluminum	Hardened stainless steel	Steel/stainless steel shaft	Stainless steel shaft	Hardened stainless steel shafts
Potential counter partner	All shaft materials	Hard-anodized aluminum	Hardened stainless steel	Steel/stainless steel shaft	All shaft materials	Stainless steel
Permissible stat. surface pressure	5,076 psi	3,336 psi	21,760 psi	2,611 psi	4,061 psi	2,176 psi
Part No.	JUI /JUM-...	J200UI / J200UM-...	XUI / XUM-...	E7UI / E7UM-...	A180UM-...	A160UM-...

drylin® W profile guides | Liners

Available pillow blocks and carriages		Suitable liners				
		 iglide® J200	 iglide® J	 iglide® X	 iglide® E7	 iglide® A180
Pillow block, square						
	Standard	●				
	Aluminum	●				
Pillow block, round						
	Standard	●	●	●	●	●
	Stainless steel	●	●	●	●	●
	Aluminum	●	●	●	●	●
	Aluminum, tandem	●	●	●	●	●
	"Turn-to-fit"		●			
	Spring pre-load	●				
	Bearing can be changed on the rail	●				
	Hybrid – roll and slide		●			
Guide carriage, fitted						
	Standard, assembled, square	●				
	Standard, assembled, round	●	●	●	●	●
	Hybrid, round		●			
	"Turn-to-fit", round		●			
Complete carriages						
	Mono-slide, square		●			

● Standard ● Optional

drylin® W profile guides | Product Range

Single rail, square, hard-anodized aluminum



WSQ-06



WSQ-10



WSQ-16



WSQ-20



WSQ-25

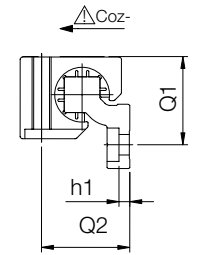
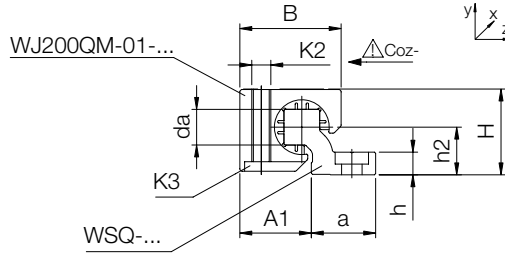
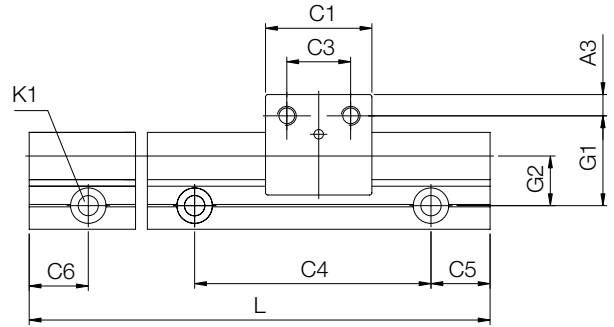

Hard-anodized surfaces
▶ Page 1092



Curved rail profiles
▶ Page 1096

Technical data and dimensions [mm]

Part No.	Weight [kg/m]	H ⁵⁷⁾	da	L	a	h	h1	h2	G1	G2	A1	Q1	Q2
		±0.25	-0.1	Max.									
WSQ-06	0.23	14	5	3,000	14	4	4 ⁵⁸⁾	7.5	18	10.5	13.5	17	15
WSQ-10	0.54	20	7.5	4,000	25	5.5	5.5 ⁵⁸⁾	11	27	17	18.5	26	21
WSQ-16	0.94	27	11.5	4,000	27	7.5	3.5	14	33	19	25	32	28
WSQ-20	1.41	36	15	4,000	27	9.5	4.5	20	38	21	30	37	37
WSQ-25	1.94	45	18.5	4,000	32	11.5	5.5	25	46.5	25.5	37.5	45.5	46

Part No.	C4	C5 Min.	C5 Max.	C6 Min.	C6 Max.	K1 for screw DIN 912	Geometrical moment of inertia		Moment of resistance	
							ly	lz	Wby	Wbz
							[mm ⁴]	[mm ⁴]	[mm ³]	[mm ³]
WSQ-06	60	20	49.5	20	49.5	M4 ⁵⁸⁾	2,200	640	220	100
WSQ-10	120	20	79.5	20	79.5	M6 ⁵⁸⁾	16,100	3,300	950	350
WSQ-16	120	20	79.5	20	79.5	M8	33,000	10,800	1,700	910
WSQ-20	120	20	79.5	20	79.5	M8	56,500	34,000	2,600	2,100
WSQ-25	150	25	99.5	25	99.5	M10	115,900	73,500	4,500	3,700

Standard hole pattern: C5 = C6, please order with drawing for C5 ≠ C6

⁵⁷⁾ Height dimension minus the bearing clearance tolerance

⁵⁸⁾ Through-holes

Can be combined with:



WJ200QM-...

1110 Lifetime calculation, configuration and more ▶ www.igus.com/drylinW

drylin® W profile guides | Product Range

Pillow blocks, square, made from zinc die-casting or aluminum

Order key –
single rail

Type Length

WSQ-06-3000

Guide rails	Square	Shafts Ø	Rail length [mm]
-------------	--------	----------	------------------

Order key –
pillow block

Type Size Options

WJ200QM-01-10-LLY

drylin® W	Liner material iglide® J200	Pillow block, square	Standard	Size	Floating bearing in y-direction
-----------	--------------------------------	----------------------	----------	------	------------------------------------

Options:

LLY: Floating bearing
in y-directionLLZ: Floating bearing
in z-directionAL: Pillow block made
from aluminum

Technical data and dimensions [mm]

Part No.	Floating bearing clearance	Floating bearing direction	Weight [g]	B	C1	C3	A3	K2	K3 for countersunk head screw	Static load capacity		
										Coy [N]	Coz+ [N]	Coz- [N]
WJ200QM-01-06	–	–	16	18	19	10	4.5	M4	M3	420	420	140
WJ200QM-01-06-AL	–	–	8	18	19	10	4.5	M4	M3	420	420	140
WJ200QM-01-06-LLY	± 0.5	y / z	16	18	19	10	4.5	M4	M3	420	420	140
WJ200QM-01-06-LLZ	± 0.5	y / z	16	18	19	10	4.5	M4	M3	420	420	140
WJ200QM-01-10	–	–	41	26	29	16	6.5	M6	M5	1,200	1,200	250
WJ200QM-01-10-AL	–	–	21	26	29	16	6.5	M6	M5	1,200	1,200	250
WJ200QM-01-10-LLY	± 0.7	y / z	41	26	29	16	6.5	M6	M5	1,200	1,200	250
WJ200QM-01-10-LLZ	± 0.7	y / z	41	26	29	16	6.5	M6	M5	1,200	1,200	250
WJ200QM-01-16	–	–	100	34.5	36	18	9	M8	M6	2,100	2,100	400
WJ200QM-01-16-AL	–	–	51	34.5	36	18	9	M8	M6	2,100	2,100	400
WJ200QM-01-16-LLY	± 1.0	y / z	100	34.5	36	18	9	M8	M6	2,100	2,100	400
WJ200QM-01-16-LLZ	± 1.0	y / z	100	34.5	36	18	9	M8	M6	2,100	2,100	400
WJ200QM-01-20	–	–	190	42.5	45	27	9	M8	M6	3,200	3,200	500
WJ200QM-01-20-AL	–	–	104	42.5	45	27	9	M8	M6	3,200	3,200	500
WJ200QM-01-20-LLY	± 1.0	y / z	190	42.5	45	27	9	M8	M6	3,200	3,200	500
WJ200QM-01-20-LLZ	± 1.0	y / z	190	42.5	45	27	9	M8	M6	3,200	3,200	500
WJ200QM-01-25	–	–	435	52.5	58	36	11	M10	M8	4,800	4,800	950
WJ200QM-01-25-AL	–	–	212	52.5	58	36	11	M10	M8	4,800	4,800	950
WJ200QM-01-25-LLY	± 1.0	y / z	435	52.5	58	36	11	M10	M8	4,800	4,800	950
WJ200QM-01-25-LLZ	± 1.0	y / z	435	52.5	58	36	11	M10	M8	4,800	4,800	950



Order example:

WJ200QM-01-06: Pillow block, square

WJ200QM-01-06-LLZ: Pillow block, square, with floating bearing in z-direction

WJ200QM-01-06-AL: Pillow block, square, made from aluminum

Can be combined with:



WSQ-...



WSQ-...



WSX-...

drylin® W profile guides | Product Range

Single rail, round, hard-anodized aluminum



WS-10



WS-16



WS-20



WS-25

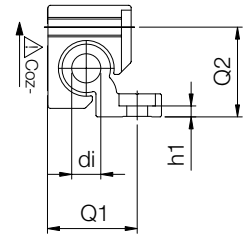
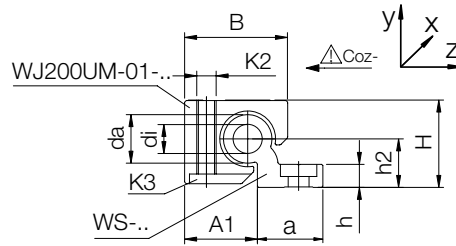
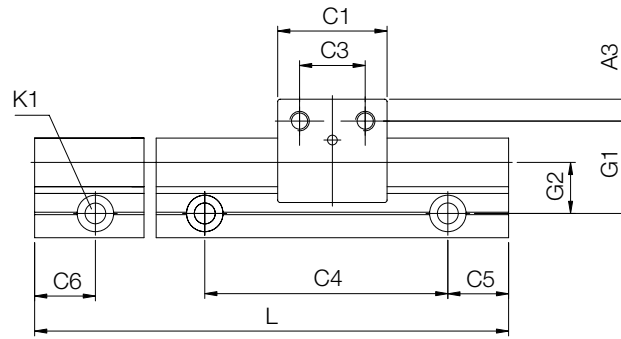

This assembled position not possible for WS-10



Hard-anodized surfaces
▶ Page 1092



Curved rail profiles
▶ Page 1096



Stainless steel version available
▶ Page 1396

Technical data and dimensions [mm]

Part No.	Weight [kg/m]	H ⁵⁷⁾ ±0.25	da -0.1	di	L Max.	a	h	h1	h2	G1	G2	A1	Q1	Q2
WS-10	0.62	18	10	-	4,000	27	5.5	5.5 ⁵⁸⁾	9	27	17	16.5	-	-
WS-16	0.98	27	16	8.0	4,000	27	7.5	3.5	14	33	19	25	32	28
WS-20	1.32	36	20	10.2	4,000	27	9.5	4.5	20	38	21	30	37	37
WS-25	2.03	45	25	14	4,000	32	11.5	5.5	25	46.5	25.5	37.5	45.5	46

Part No.	C1	C3	C4	C5 Min.	C5 Max.	C6 Min.	C6 Max.	A3	K1 for screw DIN 912	Geometrical moment of inertia		Moment of resistance	
										ly [mm ⁴]	lz [mm ⁴]	Wby [mm ³]	Wbz [mm ³]
WS-10	29	16	120	20	79.5	20	79.5	6.5	M6 ⁵⁸⁾	19,000	2,850	1,000	310
WS-16	36	18	120	20	79.5	20	79.5	9	M8	36,000	12,900	1,800	940
WS-20	45	27	120	20	79.5	20	79.5	9	M8	57,100	35,000	2,700	1,900
WS-25	58	36	150	25	99.5	25	99.5	11	M10	129,000	86,000	4,900	3,800

Standard hole pattern: C5 = C6, please order with drawing for C5 ≠ C6

⁵⁷⁾ Height dimension minus the bearing clearance tolerance

⁵⁸⁾ Through-holes

Can be combined with:



WJ200UM(T)-...



WJ200UME-...



WJUM-...-ES-FG



WJRM-...

drylin® W profile guides | Product Range

Single rails round, made of 316 stainless steel

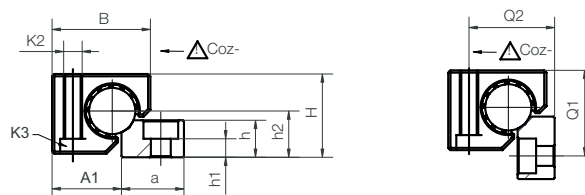
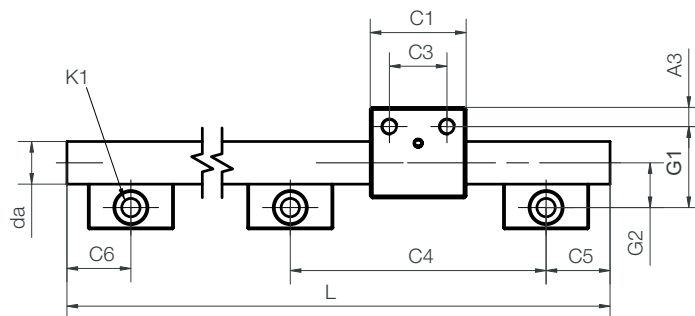

This assembled position is not possible for WS-10



Housing and shaft support material **AISI 316**
Shaft material **AISI 316Ti**
Installation size 25
Shaft, shaft support and housing material **AISI 316Ti**

Technical data and dimensions [mm]

Part No.	Weight [kg/m]	H ⁵⁷⁾ ±0.25	da -0.1	L Max.	a -0.3	h	h1	h2	G1	G2	A1	Q1	Q2
WS-10-ES-FG	0.87	18	10	3,000	27	5.5	5.5 ⁵⁸⁾	9	27	17	16.5	-	-
WS-16-ES-FG	2.22	27	16	3,000	27	12.0	4.5	14	33	19	25	32	28
WS-20-ES-FG	3.37	36	20	3,000	27	16.0	8.0	20	38	21	30	37	37
WS-25-ES-FG	5.21	45	25	3,000	32	20.0	9.0	25	46.5	25.5	37.5	45.5	46

Part No.	C1	C3	C4	C5		C6		A3	K1 for screw	Geometrical moment of inertia		Moment of resistance	
				Min.	Max.	Min.	Max.			ly [mm ²]	lz [mm ²]	Wby [mm ³]	Wbz [mm ³]
WS-10-ES-FG	29	16	120	20	79.5	20	79.5	6.5	M6 ⁵⁸⁾	491	491	98	98
WS-16-ES-FG	36	18	120	20	79.5	20	79.5	9.0	M8	3,217	3,217	402	402
WS-20-ES-FG	45	27	120	20	79.5	20	79.5	9.0	M8	7,854	7,854	785	785
WS-25-ES-FG	58	36	150	25	99.5	25	99.5	11.0	M10	19,175	19,175	1,534	1,534

⁵⁷⁾ Height dimension minus the bearing clearance tolerance

⁵⁸⁾ Through-holes

Can be combined with:



Suitable liner material:



drylin® W profile guides | Product Range

Pillow blocks, round, made from zinc die-casting or aluminum



Cast zinc



Machined
aluminum



Cast stainless steel



Order key –
single rail



Order key –
pillow block

Type	Length
------	--------

WS-10-4000

Guide rails	Shafts Ø	Rail length [mm]
-------------	----------	------------------

Type	Size	Options
------	------	---------

WJ200UM-01-10-LL

drylin® W	Liner material iglide® J200	Pillow block, round	Standard	Size	Floating bearing
-----------	--------------------------------	---------------------	----------	------	------------------

Options:
LL: Floating bearing
AL: Pillow block
 made from
 aluminum
ES: Stainless steel
ES-FG: Stainless steel
 precision
 casting

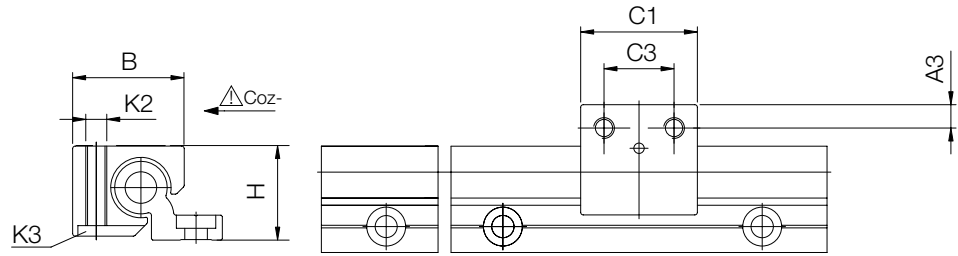

Note: H dimension can be found with rail/shafting selections

Technical data and dimensions [mm]

Part No.	Floating bearing clearance	Weight [g]	B	C1	C3	A3	K2	K3	Static load capacity		
									for countersunk head screw	Co _y [N]	Co _{z+} [N]
WJ200UM-01-10	–	41	26.0	29	16	6.5	M6	M5	1,200	1,200	250
WJ200UM-01-10-LL	±0.2	41	26.0	29	16	6.5	M6	M5	1,200	1,200	250
WJ200UM-01-10-AL	–	20	26.0	29	16	6.5	M6	M5	1,200	1,200	250
WJUM-01-10-ES-FG ⁹⁹	–	57	26.0	29	16	6.5	M6	M5	3,800	3,800	950
WJ200UM-01-16	–	100	34.5	36	18	9.0	M8	M6	2,100	2,100	400
WJ200UM-01-16-LL	±0.2	100	34.5	36	18	9.0	M8	M6	2,100	2,100	400
WJ200UM-01-16-AL	–	48	34.5	36	18	9.0	M8	M6	2,100	2,100	400
WJUM-01-16-ES-FG ⁹⁹	–	134	34.5	36	18	9.0	M8	M6	6,900	6,900	1,450
WJ200UM-01-20	–	190	42.5	45	27	9.0	M8	M6	3,200	3,200	500
WJ200UM-01-20-LL	±0.25	190	42.5	45	27	9.0	M8	M6	3,200	3,200	500
WJ200UM-01-20-AL	–	99	42.5	45	27	9.0	M8	M6	3,200	3,200	500
WJUM-01-20-ES-FG ⁹⁹	–	280	42.5	45	27	9.0	M8	M6	11,000	11,000	1,900
WJ200UM-01-25	–	425	52.5	58	36	11.0	M10	M8	4,800	4,800	950
WJ200UM-01-25-LL	±0.25	425	52.5	58	36	11.0	M10	M8	4,800	4,800	950
WJ200UM-01-25-AL	–	250	52.5	58	36	11.0	M10	M8	4,800	4,800	950
WJUM-01-25-ES-FG ⁹⁹	–	564	52.5	58	36	11.0	M10	M8	16,000	16,000	3,600

⁹⁹ Alternative with XUM0-01-... liners for high temperatures available. Part No.: WXUM-01-...



Order example:

WJ200UM-01-10: Pillow block, round

WJ200UM-01-10-LL: Pillow block, round, floating bearing

WJ200UM-01-10-AL: Pillow block, round, made from aluminum

drylin® W profile guides | Product Range

Pillow blocks, tandem, round, anodized aluminum

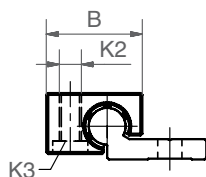

Order key

Type Size Material

WJ200UMT-01-10-AL

drylin® W	Liner material iglide® J200	Pillow block, round	Tandem	Standard	Size	Aluminum
-----------	--------------------------------	---------------------	--------	----------	------	----------

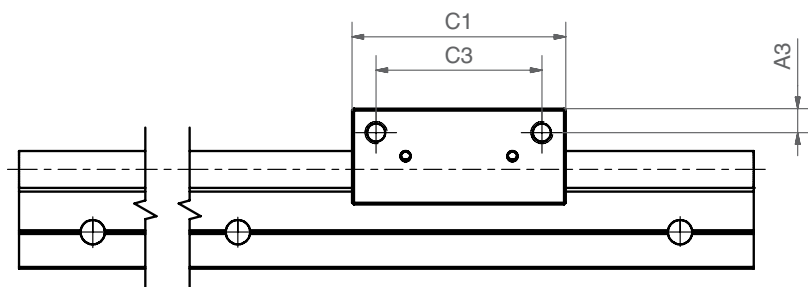

Technical data and dimensions [mm]

Part No.	Weight [g]	B	C1	C3	A3	K2	K3 for countersunk head screw	Static load capacity		
								Co _y [N]	Co _{z+} [N]	Co _{z-} [N]
WJ200UMT-01-10-AL	43	26	58	45	6.5	M6	M5	2,000	2,000	420
WJ200UMT-01-16-AL	102	34.5	72	54	9	M8	M6	3,400	3,400	670
WJ200UMT-01-20-AL	182	42.5	80	62	9	M8	M6	5,300	5,300	830

Can be combined with:



WS-... WS-...-ES-FG-... WS-... WS-...-ES-FG WSX-...

Suitable liner material:



J J200 X E7 A180

drylin® W profile guides | Product Range

Pillow blocks, round, adjustable bearing clearance



Cast zinc



Machined aluminum



Cast stainless steel



Order key

Type **WJ200UME-01-16** Size

drylin® W	Liner material iglide® J200	Pillow block, round	Adjustable	Standard	Size
-----------	--------------------------------	---------------------	------------	----------	------

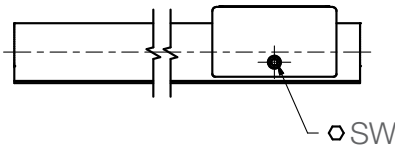
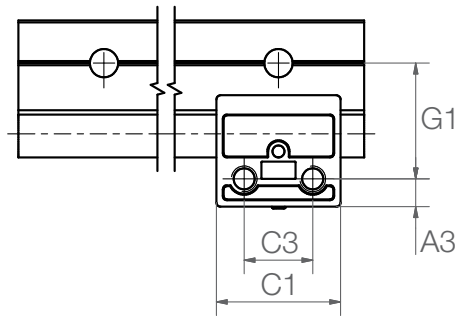
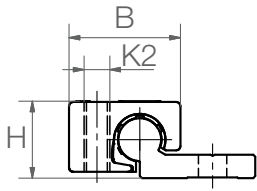

Allen key supplied



Technical data and dimensions [mm]

Part No.	Weight [g]	B	C1	C3	A3	K2	H	SW	G1	Static load capacity		
										Coy [N]	Coz+ [N]	Coz- [N]
WJUME-01-10	43	26	29	16	6.5	M6	±0.25 18	1.5	27	560	560	250
WXUME-01-10	43	26	29	16	6.5	M6	18	1.5	27	560	560	250
WJUME-01-10-AL	19	26	29	16	6.5	M6	18	1.5	27	560	560	250
WJUME-01-10-ES	56	26	29	16	6.5	M6	18	1.5	27	560	560	250
WJ200UME-01-16	110	34.5	36	18	9	M8	27	2.5	33	980	980	400
WJ200UME-01-16-AL	45	34.5	36	18	9	M8	27	2.5	33	980	980	400
WJ200UME-01-16-ES	132	34.5	36	18	9	M8	27	2.5	33	980	980	400
WJ200UME-01-20	222	42.5	45	27	9	M8	36	2.5	38	1,500	1,500	500
WJ200UME-01-20-AL	95	42.5	45	27	9	M8	36	2.5	38	1,500	1,500	500
WJ200UME-01-20-ES	275	42.5	45	27	9	M8	36	2.5	38	1,500	1,500	500
WJ200UME-01-25*	431	52.5	58	36	11	M10	45	2.5	46.5	2,250	2,250	950
WJ200UME-01-25-AL*	194	52.5	58	36	11	M10	45	2.5	46.5	2,250	2,250	950
WJ200UME-01-25-ES*	539	52.5	58	36	11	M10	45	2.5	46.5	2,250	2,250	950

Can be combined with:



Suitable liner material:



drylin® W profile guides | Product Range

Pillow blocks, round, with spring pre-load



Cast zinc

Machined aluminum

Cast stainless steel

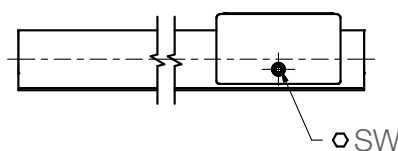
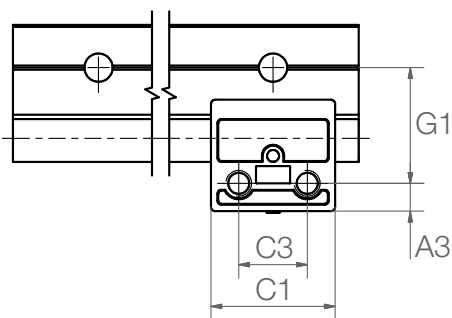
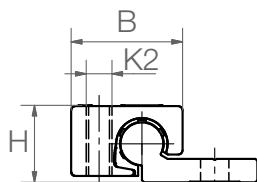

Order key

Type	Size	Material
WJ200UM-01-16-□-P40		
drylin® W	Liner material iglide® J200	Pillow block, round
Standard	Size	Housing material
		Pre-load

Housing material:

Blank = Zinc die-casting

AL = Aluminum

ES = Stainless steel

(AISI 316Ti, machined)

Technical data and dimensions [mm]

Part No.	Pre-load		Weight		B	C1	C3	A3	K2	H	SW	G1
	[N]	[g]	-ES [g]	-AL [g]								
WJ200UM-01-10-□-P40	4	43	56	19	26	29	16	6.5	M6	±0.25 18	1.5	27
WJ200UM-01-10-□-P90	9	43	56	19	26	29	16	6.5	M6	18	1.5	27
WJ200UM-01-10-□-P140	14	43	56	19	26	29	16	6.5	M6	18	1.5	27
WJ200UM-01-16-□-P40	4	110	132	46	34.5	36	18	9	M8	27	2.5	33
WJ200UM-01-16-□-P90	9	110	132	46	34.5	36	18	9	M8	27	2.5	33
WJ200UM-01-16-□-P140	14	110	132	46	34.5	36	18	9	M8	27	2.5	33
WJ200UM-01-16-□-P230	23	110	132	46	34.5	36	18	9	M8	27	2.5	33
WJ200UM-01-20-□-P40	4	222	275	95	42.5	45	27	9	M8	36	2.5	38
WJ200UM-01-20-□-P90	9	222	275	95	42.5	45	27	9	M8	36	2.5	38
WJ200UM-01-20-□-P140	14	222	275	95	42.5	45	27	9	M8	36	2.5	38
WJ200UM-01-20-□-P230	23	222	275	95	42.5	45	27	9	M8	36	2.5	38

Can be combined with:



WS-...

WS-...-ES-FG-...

WS-...

WS-...-ES-FG

WSX-...

Suitable liner material:



J

J200

drylin® W profile guides | Product Range

Pillow blocks, round; change the liner without disassembly



Order key



Type Size

WJ200UMA-01-10-AL

drylin® W	Liner material iglide® J200	Pillow block, round	Replaceable	Standard	Size	Aluminum
-----------	--------------------------------	---------------------	-------------	----------	------	----------

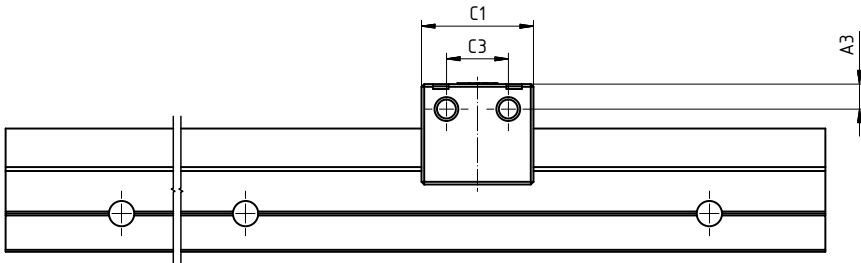
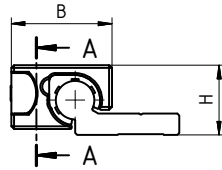
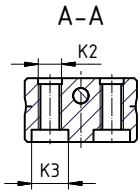

Technical data and dimensions [mm]

Part No.	Weight [g]	B	C1	C3	A3	K2	K3 ¹⁵⁰	H ±0.25	Static load capacity		
									Co _y [N]	Co _{z+} [N]	Co _{z-} [N]
WJ200UMA-01-10-AL	18	26	29	16	6.5	M6	M5	18	1,000	1,000	200
WJ200UMA-01-16-AL	44	34.5	36	18	9	M8	M6	27	1,250	1,250	275
WJ200UMA-01-20-AL	91	42.5	45	27	9	M8	M6	36	1,500	1,500	350

¹⁵⁰ Counterbore for socket cap bolt

Can be combined with:



Suitable liner material/accessories



Notes

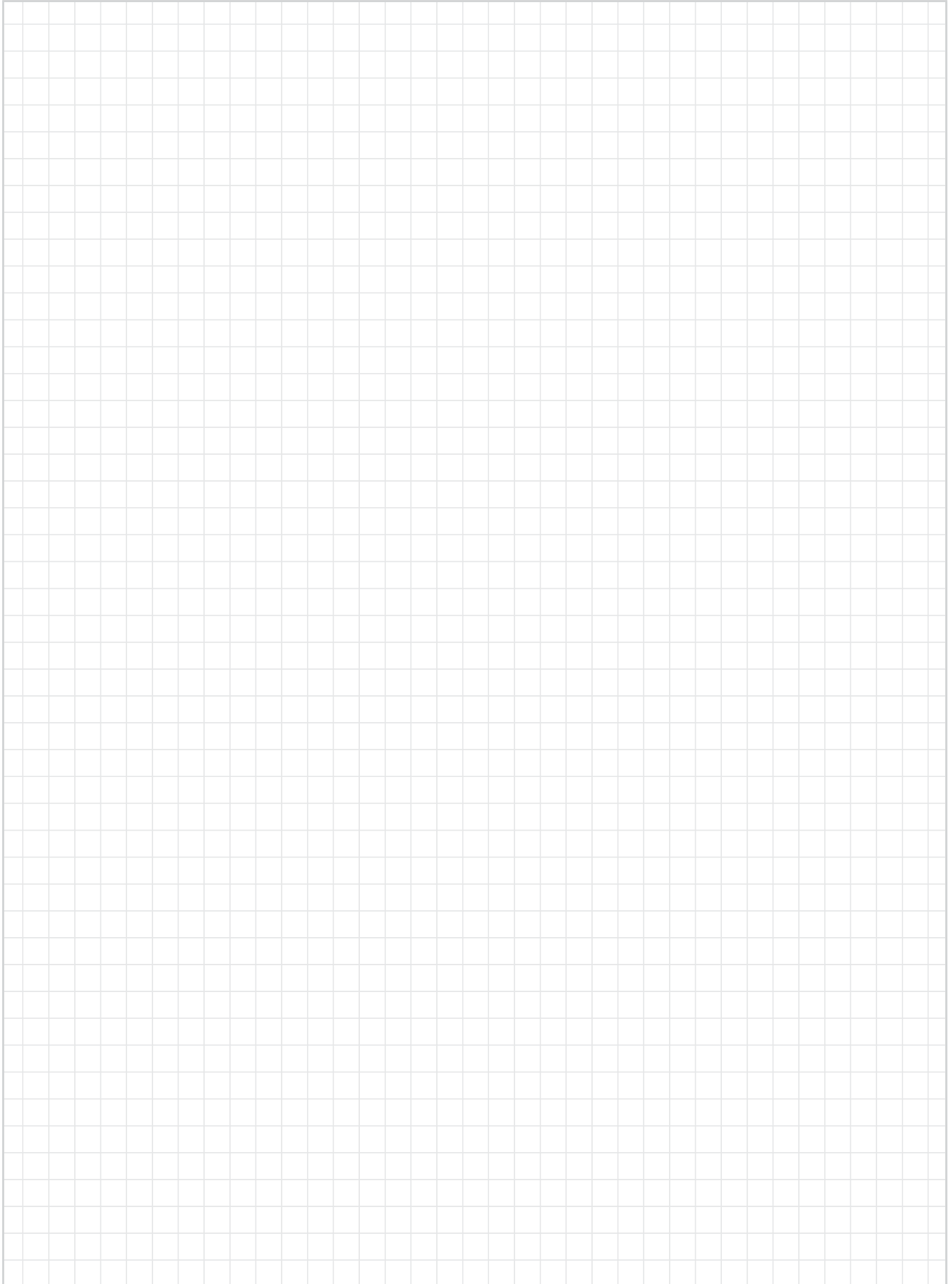

drylin® W profile guides | Product Range

Double rails, square, hard-anodized aluminum

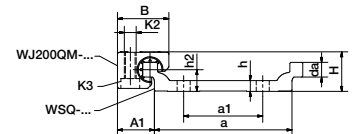
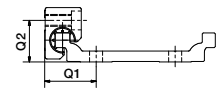
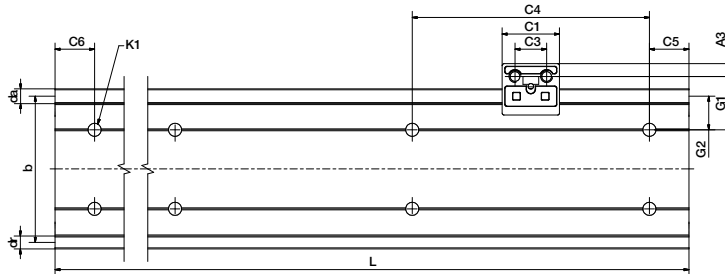
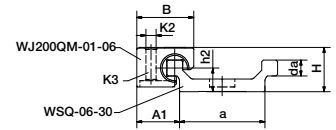
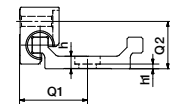
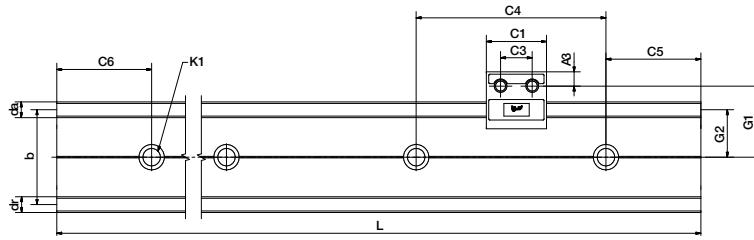

Hard-anodized surfaces
▶ Page 1092



Curved rail profiles
▶ Page 1096

Technical data and dimensions [mm]

Part No.	Weight [kg/m]	H ⁵⁷⁾ ±0.25	da -0.1	dr	L Max.	a	A1	b	h	h1	h2	G1	G2	a1 ⁵⁹⁾	Q1	Q2
WSQ-06-30	0.45	14	5	5	3,000	27-0.4	13.5	30	4	4 ⁵⁸⁾	7.5	22.5	15	-	21.5	15
WSQ-06-60	0.70	14	5	5	3,000	58-0.4	13.5	61	4	4 ⁵⁸⁾	7.0	42.5	30.5	40	17	15
WSQ-10-40	0.92	20	7.5	6.7	4,000	36-0.5	18.5	40	5.5	5.5 ⁵⁸⁾	11	30	20	-	29	21
WSQ-10-80	1.41	20	7.5	6.7	4,000	70-0.7	18.5	74	5.5	5.5 ⁵⁸⁾	11	27	17	40	26	21
WSQ-10-120	2.02	20	7.5	6.7	4,000	116-0.7	18.5	120	5.5	5.5 ⁵⁸⁾	11	30	20	80	29	21
WSQ-16-60	1.84	27	11.5	10.7	4,000	54-0.5	35.5	58	7.5	3.5	14	43	29	-	42	28
WSQ-20-80	3.30	36	15	14.1	4,000	74-0.7	30.0	82	9.5	4.5	20	38	21	40	37	37

Part No.	C4	C5		C6		K1 for screw DIN 912	Geometrical moment of inertia		Moment of resistance	
		Min.	Max.	Min.	Max.		I _y	I _z	W _{by}	W _{bz}
							[mm ⁴]	[mm ⁴]	[mm ³]	[mm ³]
WSQ-06-30	60	20	49.5	20	49.5	M5 ⁵⁹⁾	19,000	1,250	1,100	200
WSQ-06-60	60	20	49.5	20	49.5	M5 ⁵⁹⁾	117,900	1,600	3,500	290
WSQ-10-40	120	20	79.5	20	79.5	M6 ⁵⁹⁾	71,600	5,580	3,000	610
WSQ-10-80	120	20	79.5	20	79.5	M6 ⁵⁹⁾	335,000	7,070	8,300	700
WSQ-10-120	120	20	79.5	20	79.5	M6 ⁵⁹⁾	1,175,000	8,000	18,400	760
WSQ-16-60	120	20	79.5	20	79.5	M8	324,700	20,500	9,400	1,700
WSQ-20-80	120	20	79.5	20	79.5	M8	1,145,000	75,300	23,600	4,500

⁵⁷⁾ Height dimension minus the bearing clearance tolerance ⁵⁸⁾ With through-holes

⁵⁹⁾ WSQ-06-30/-10-40/-16-60 a single row of mounting holes down the centerline, WSQ-06-60/10-80/-10-120/-20-80 two parallel rows of mounting holes

Can be combined with:



WJQM...



WW...



WWC...

drylin® W profile guides | Product Range

High profile rails, square, hard-anodized aluminum

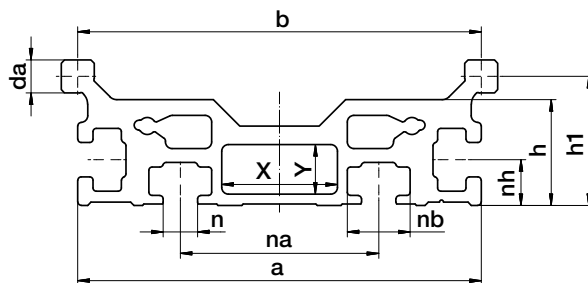
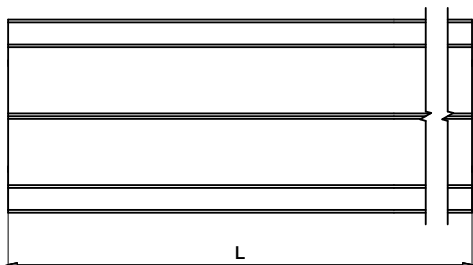
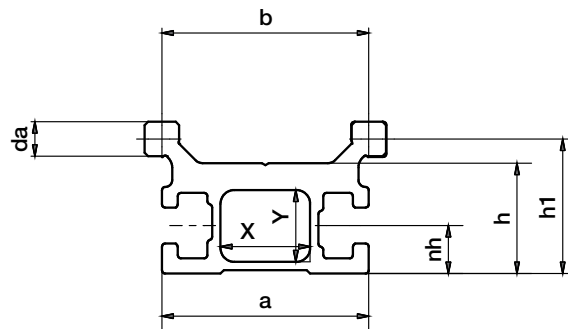

Suitable end caps

► Page 1159

Technical data and dimensions [mm]

Part No.	Weight [kg/m]	da	L	a	b	h	h1	nh	n	nb	na	X	Y	Geometrical moment of inertia		Moment of resistance	
														ly [mm ⁴]	lz [mm ⁴]	Wby [mm ³]	Wbz [mm ³]
WSX-06-30	0.76	5	4,000	29.7	30	16	19.5	7	-	-	-	12	10	30,391	11,674	1,736	845
WSX-06-60	1.39	5	4,000	61	61	16	19.5	6.9	5.2	9.5	30	17.5	7.5	212,826	17,018	6,448	1,398



Order key

Type Length

WS Q-06-30-3000

Profile rail	Square	Shaft Ø	Rail width [mm]	Rail length [mm]
--------------	--------	---------	-----------------	------------------



Order example:

WSX-06-30/06-60: High profile rail, square

WSQ-06-30: Standard double rail, square



Order key

Type Length

WS X-06-30-4000

Profile rail	High profile rail	Shaft Ø	Rail width [mm]	Rail length [mm]
--------------	-------------------	---------	-----------------	------------------

Can be combined with:



WJQM-...



WW-...



WWC-...

drylin® W profile guides | Product Range

Linear guides – lightweight, non-metallic, strong and X-ray transparent

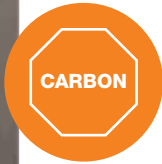

Order key

Type		Dimensions				
W S P C -06-30-1000						
drylin® W	Rail	Plastic	Carbon fiber	Shaft Ø	Rail width	Rail length

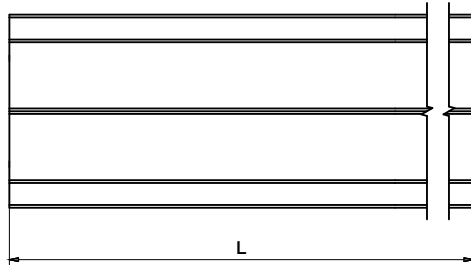
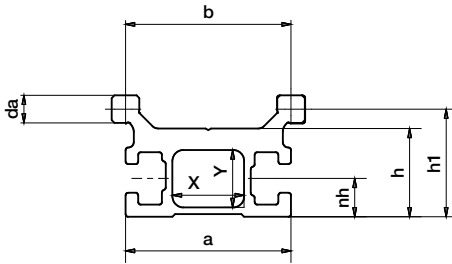

Technical data – guide rail

Part No.	F max. radial		Weight [g/m]	I _y [mm ⁴]	I _z [mm ⁴]
	stat. [N]	dyn. [N]			
WSPC-06-30	300	60	410	30,391	11,674

Dimensions [mm] – guide profile

Part No.	a	b	da -0.1	h	h1	nh	X	Y	L
WSPC-06-30	30	30	5	16	19.5	7	13	10	3,000

drylin® W profile guides | Product Range

Linear guides – lightweight, non-metallic, strong and cost-effective



Order key

Type		Dimensions				
drylin® W	Rail	Plastic	Fiberglass	Shaft Ø	Rail width	Rail length
W S P G-06-30-1000						

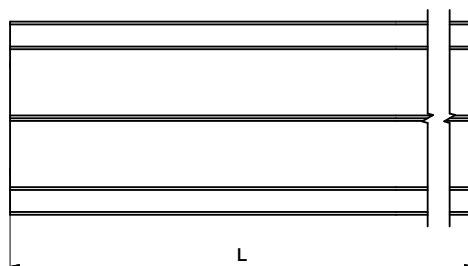
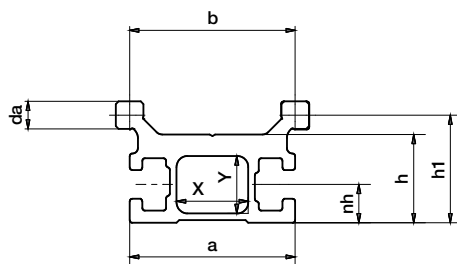

Technical data – guide rail

Part No.	F max. radial		Weight	I _y	I _z
	stat. [N]	dyn. [N]			
WSPG-063001	200	50	505	30,391	11,674

Dimensions [mm] – guide profile

Part No.	a	b	da	h	h1	nh	X	Y	L
WSPG-063001	30	30	5 -0.1	16	19.5	7	13	10	2,000

Dimensions [mm] – complete system

Part No.	H	A1	A	A2	C	C2
WSPG-063001	30	12	52	45	60	51

drylin® W profile guides | Product Range

Guide carriages, assembled, square

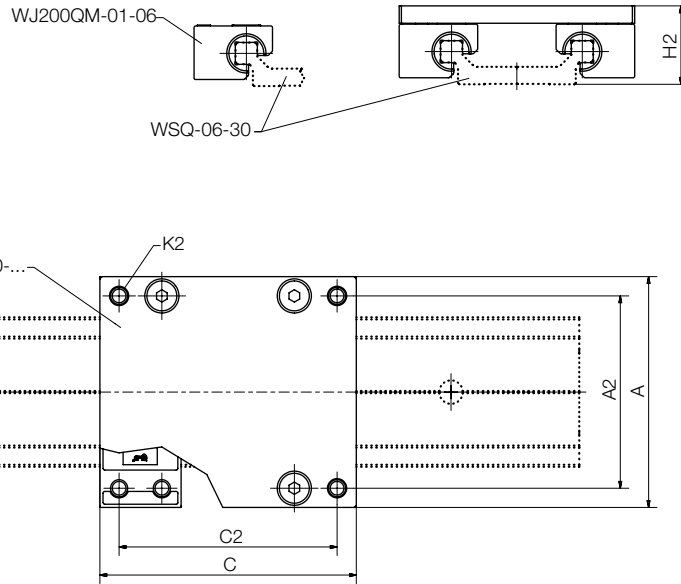

Order key

Type	Size
WWQ-06-30-06	

Guide carriage
Square
Shafts-Ø [mm]
Profile width
Carriage length

Technical data and dimensions [mm]

Part No. ⁵⁰⁾	Weight [kg]	A		A2	C2	K2	H2 ⁵¹⁾ ±0.25	Static load capacity				
		Width	Length					Coy [N]	Coz [N]	Mox [Nm]	Moy [Nm]	Moz [Nm]
WWQ-06-30-06	0.10	54	60	45	51	M4	18	1,680	840	25	34	34
WWQ-06-30-08	0.11	54	80	45	71	M4	18	1,680	840	25	51	51
WWQ-06-30-10	0.12	54	100	45	91	M4	18	1,680	840	25	68	68
WWQ-06-60-06	0.13	85	60	76	51	M4	18	1,680	840	50	34	34
WWQ-06-60-08	0.15	85	80	76	71	M4	18	1,680	840	50	51	51
WWQ-06-60-10	0.17	85	100	76	91	M4	18	1,680	840	50	68	68
WWQ-10-40-10	0.29	73	100	60	87	M6	26	4,800	2,400	96	170	170
WWQ-10-40-15	0.34	73	150	60	137	M6	26	4,800	2,400	96	290	290
WWQ-10-40-20	0.40	73	200	60	187	M6	26	4,800	2,400	96	410	410
WWQ-10-80-10	0.34	107	100	94	87	M6	26	4,800	2,400	178	170	170
WWQ-10-80-15	0.42	107	150	94	137	M6	26	4,800	2,400	178	290	290
WWQ-10-80-20	0.50	107	200	94	187	M6	26	4,800	2,400	178	410	410
WWQ-10-120-10	0.41	153	100	140	87	M6	26	4,800	2,400	288	170	170
WWQ-10-120-15	0.54	153	150	140	137	M6	26	4,800	2,400	288	290	290
WWQ-10-120-20	0.66	153	200	140	187	M6	26	4,800	2,400	288	410	410
WWQ-16-60-10	0.71	104	100	86	82	M8	35	8,400	4,200	240	270	270
WWQ-16-60-15	0.84	104	150	86	132	M8	35	8,400	4,200	240	480	480
WWQ-16-60-20	0.97	104	200	86	182	M8	35	8,400	4,200	240	690	690
WWQ-20-80-15	1.20	134	150	116	132	M8	44	12,800	6,400	525	670	670
WWQ-20-80-20	1.30	134	200	116	182	M8	44	12,800	6,400	525	990	990
WWQ-20-80-25	1.50	134	250	116	232	M8	44	12,800	6,400	525	1,250	1,250

⁵⁰⁾ Height dimension minus the bearing clearance tolerance ⁵¹⁾ Optionally available with manual clamp, suffix "-HKA"

Can be combined with:



WSQ-...



WSXQ-...

Suitable liner material:



J200

drylin® W profile guides | Product Range

Mono-slide carriages, anodized aluminum

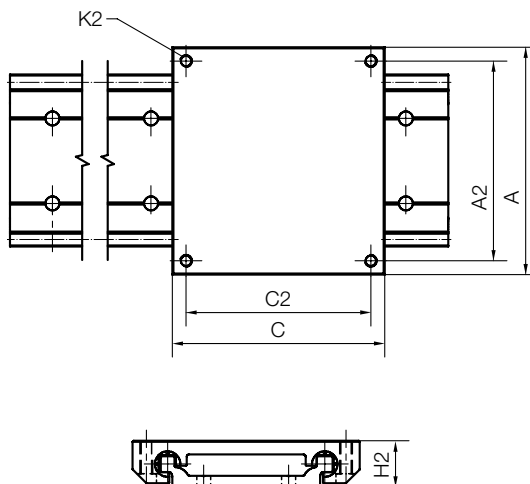

Order key

Type Size
WWC-10-40-10

Mono-Slide
guide carriage

Shafts-Ø [mm]

Profile width

Carriage length

Technical data and dimensions [mm]

Part No.	Weight [kg]	A Width	C Length	A2	C2	K2	H2 ^{m)} ±0.2	Static load capacity				
								Coy [N]	Coz [N]	Mox [Nm]	Moy [Nm]	Moz [Nm]
WWC-06-30-06	0.07	54	60	45	51	M4	16	1,680	840	25	34	34
WWC-06-30-08	0.09	54	80	45	71	M4	16	1,680	840	25	51	51
WWC-06-30-10	0.12	54	100	45	91	M4	16	1,680	840	25	68	68
WWC-10-40-10	0.21	73	100	60	87	M6	22	4,800	2,400	96	170	170
WWC-10-40-15	0.32	73	150	60	137	M6	22	4,800	2,400	96	290	290
WWC-10-40-20	0.42	73	200	60	187	M6	22	4,800	2,400	96	410	410
WWC-10-80-10	0.28	107	100	94	87	M6	22	4,800	2,400	178	170	170
WWC-10-80-15	0.42	107	150	94	137	M6	22	4,800	2,400	178	290	290
WWC-10-80-20	0.56	107	200	94	187	M6	22	4,800	2,400	178	410	410
WWC-10-120-10	0.36	153	100	140	87	M6	22	4,800	2,400	288	170	170
WWC-10-120-15	0.54	153	150	140	137	M6	22	4,800	2,400	288	290	290
WWC-10-120-20	0.72	153	200	140	187	M6	22	4,800	2,400	288	410	410
WWC-16-60-10	0.41	104	100	86	82	M8	30	8,400	4,200	240	270	270
WWC-16-60-15	0.61	104	150	86	132	M8	30	8,400	4,200	240	480	480
WWC-16-60-20	0.80	104	200	86	182	M8	30	8,400	4,200	240	690	690
WWC-20-80-15	0.99	134	150	116	132	M8	40	12,800	6,400	525	670	670
WWC-20-80-20	1.33	134	200	116	182	M8	40	12,800	6,400	525	990	990
WWC-20-80-25	1.66	134	250	116	232	M8	40	12,800	6,400	525	1,250	1,250

^{m)} Height dimension minus the bearing clearance tolerance

Can be combined with:



WSQ...



WSXQ...

Suitable liner material:



J

drylin® W profile guides | Product Range

Double rails, round, hard-anodized aluminum

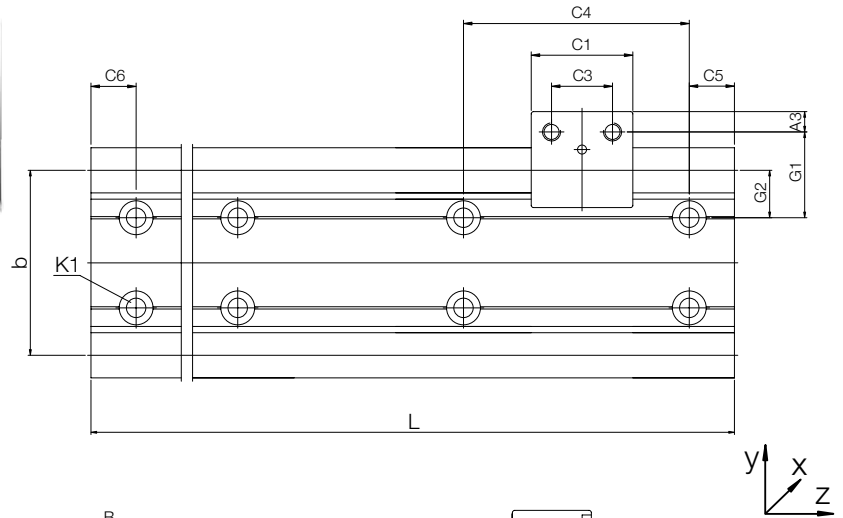

Hard-anodized surfaces
▶ Page 1092



Curved rail profiles
▶ Page 1096

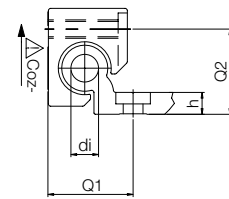
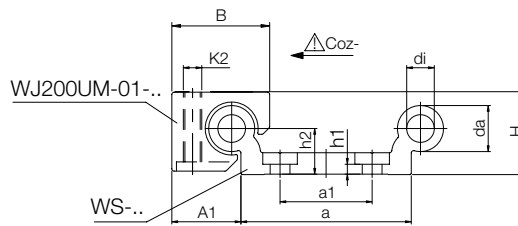

This orientation not possible for
WS-10-40/
WS-10-80/WS-10-120

Technical data and dimensions [mm]

Part No.	Weight [kg/m]	H ^{m)} ±0.25	da	di	L Max.	a	A1	b	h	h1	h2	G1	G2	a1 ^{o)}	Q1	Q2
WS-10-30	0.85	18	10-0.1	-	4,000	30-0.5	16.5	30	5.5	5.5 ^{o)}	9	25	15	-	-	-
WS-10-40	1.00	18	10-0.1	-	4,000	40-0.5	16.5	40	5.5	5.5 ^{o)}	9	30	20	-	-	-
WS-10-80	1.50	18	10-0.1	-	4,000	74-0.7	16.5	74	5.5	5.5 ^{o)}	9	27	17	40	-	-
WS-10-120	2.02	18	10-0.1	-	4,000	120-	16.5	120	5.5	5.5 ^{o)}	9	30	20	80	-	-
WS-16-60	1.96	27	16-0.1	8.0	4,000	54-0.5	25.0	58	7.5	3.5	14	43	29	-	32	28
WS-20-80	3.30	36	20-0.1	10.2	4,000	74-0.7	30.0	82	9.5	4.5	20	38	21	40	37	37
WS-25-120	5.8	45	25-0.15	14.0	4,000	120-0.7	37.5	131	11.5	5.5	25	46.5	25.5	80	45.5	46

^{m)} Height dimension minus the bearing clearance tolerance

^{o)} WS-10-40/-16-60 a single row of mounting holes down the centerline; WS-10-80/-10-120/-20-80/-25-120 two parallel rows of mounting holes

Part No.	C4		C5		C6		K1 for screw DIN 912	Geometrical moment of inertia		Moment of resistance	
	Min.	Max.	Min.	Max.	Min.	Max.		I _y [mm ⁴]	I _z [mm ⁴]	W _{by} [mm ³]	W _{bz} [mm ³]
WS-10-30	120	20	79.5	20	79.5	M5 ^{m)}	47,500	4,400	2,370	540	
WS-10-40	120	20	79.5	20	79.5	M6 ^{m)}	91,000	5,100	3,600	590	
WS-10-80	120	20	79.5	20	79.5	M6 ^{m)}	388,000	6,100	9,200	650	
WS-10-120	120	20	79.5	20	79.5	M6 ^{m)}	1,303,000	7,100	20,000	720	
WS-16-60	120	20	79.5	20	79.5	M8	367,600	26,100	9,900	1,900	
WS-20-80	120	20	79.5	20	79.5	M8	1,080,000	78,700	21,000	4,000	
WS-25-120	150	25	99.5	25	99.5	M10	4,867,000	215,000	62,400	8,500	

Standard hole pattern: C5 = C6, please order with drawing for C5 ≠ C6.

^{o)} Through-holes

drylin® W profile guides | Product Range

High profile rails, round, hard-anodized aluminum



WSX-10-40



WSX-10-80



WSX-16-60

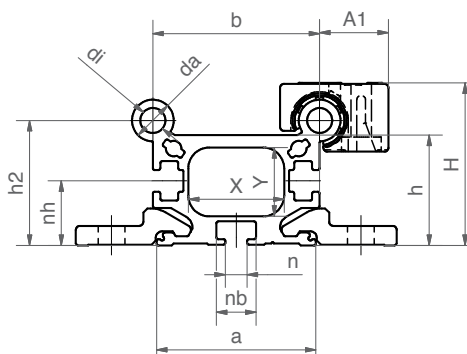

Technical data and dimensions [mm]

Part No.	Weight	H ^{*)}	da	di	L	a	A1	b	h	h2	s	K1	C1	C3	G1
	[kg/m]	±0.25	-0.1		Max.										
WSX-10-40	1.3	39 ±0.02	10	6	4,000	38.2	16.5	40	26.5	30	60	M6	29	16	30
WSX-10-80	2	39 ±0.02	10	6	4,000	72.2	16.5	74	26.5	30	94	M6	29	16	47
WSX-16-60	4.2	65 ±0.02	16	6	4,000	62	25	58	49	52	100	M8	36	18	50

nh	n	nb	X	Y	Surface inertia-moment		Moment of resistance		
					ly	lz	Wby	Wbz	
						[mm ²]	[mm ²]	[mm ³]	[mm ³]
15.5	5.2	9.5	23	16		97,560	54,910	3,902	3,074
15.5	5.2	9.5	55	16		483,653	83,613	11,515	4,684
27.6	10	15.4	40	27.0		540,876	773,489	14,618	24,586

^{*)} Height dimension minus the bearing clearance tolerance



Order key

Type	Length
------	--------

WS-10-40-3000

Profile rail, round
Shaft Ø
Rail width [mm]
Rail length [mm]



Order key

Type	Length
------	--------

WS X-10-40-4000

Profile rail
High profile rail
Shaft Ø
Rail width [mm]
Rail length [mm]

drylin® W profile guides | Product Range

Round double rails made of 316 stainless steel

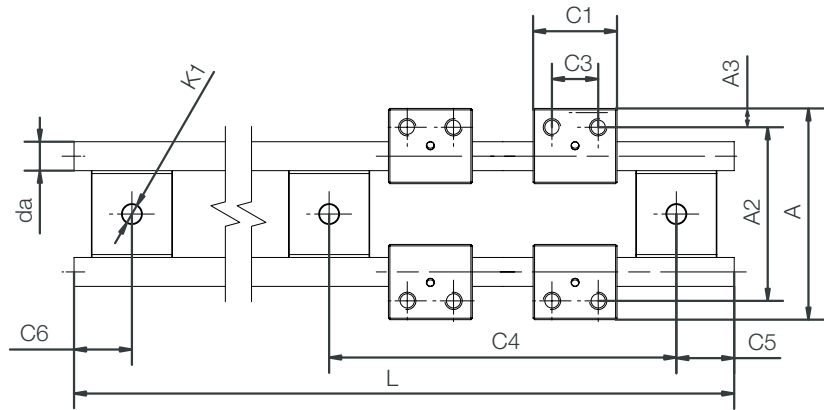

Installation size 10-20

Housing and shaft support material

Shaft material

Installation size 25

Shaft, shaft support and housing material

AISI 316

AISI 316Ti

AISI 316Ti

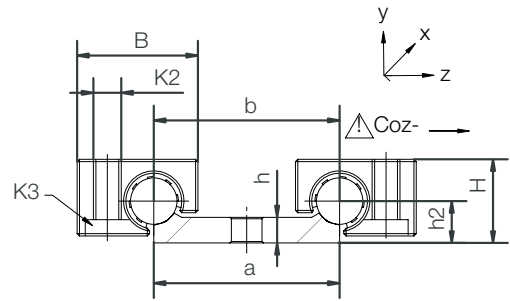

Technical data and dimensions [mm]

Part No.	Weight [kg/m]	H ⁵⁾ ±0.25	da h9	L Max.	a -0.3	b	h	h2	A	A2
WS-10-40-ES-FG	1.58	18	10	3,000	40	40	5.5	9	73	60
Part No.	C4	C5 Min.	C5 Max.	C6 Min.	C6 Max.	K1 for screw		DIN 912		
WS-10-40-ES-FG	120	20	79.5	20	79.5	M6				

⁵⁾ Height dimension minus the bearing clearance tolerance

drylin® W profile guides | Product Range

Assembled guide carriages, round

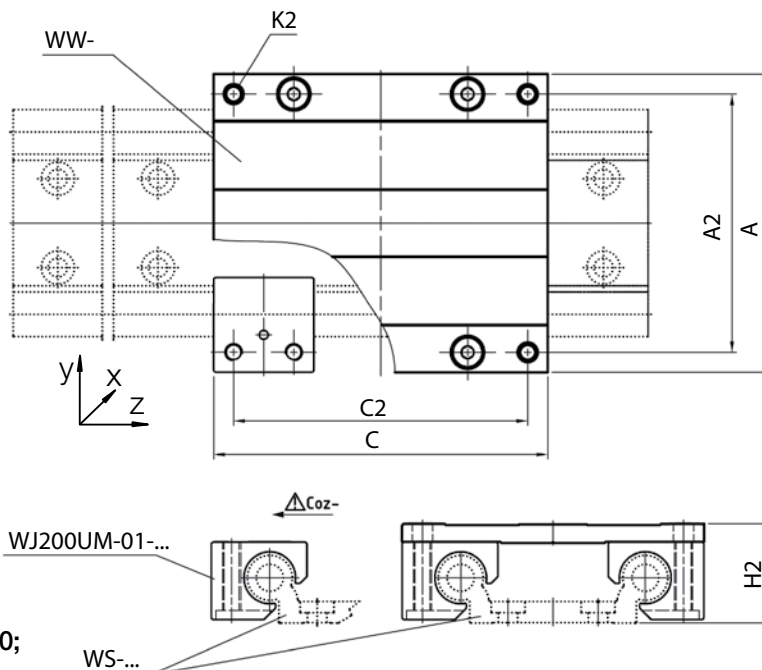

i In the following sizes, also available with adjustable bearing clearance: 10, 16 and 20; order example: WWE-10-40-15

Technical data and dimensions [mm]

Part No. ⁹⁰	Weight [kg]	A Width	C Length	A2	C2	K2	H2 ⁹¹ ±0.25	Static load capacity				
								Coy [N]	Coz [N]	Mox [Nm]	Moy [Nm]	Moz [Nm]
WW-10-30-08	0.26	63	80	50	67	M6	24	4,800	2,400	72	120	120
WW-10-30-10	0.28	63	100	50	87	M6	24	4,800	2,400	72	170	170
WW-10-30-15	0.32	63	150	50	137	M6	24	4,800	2,400	72	290	290
WW-10-40-10	0.29	73	100	60	87	M6	24	4,800	2,400	96	170	170
WW-10-40-15	0.34	73	150	60	137	M6	24	4,800	2,400	96	290	290
WW-10-40-20	0.40	73	200	60	187	M6	24	4,800	2,400	96	410	410
WW-10-80-10	0.34	107	100	94	87	M6	24	4,800	2,400	178	170	170
WW-10-80-15	0.42	107	150	94	137	M6	24	4,800	2,400	178	290	290
WW-10-80-20	0.50	107	200	94	187	M6	24	4,800	2,400	178	410	410
WW-10-120-10	0.41	153	100	140	87	M6	24	4,800	2,400	288	170	170
WW-10-120-15	0.54	153	150	140	137	M6	24	4,800	2,400	288	290	290
WW-10-120-20	0.66	153	200	140	187	M6	24	4,800	2,400	288	410	410
WW-16-60-10	0.71	104	100	86	82	M8	35	8,400	4,200	240	270	270
WW-16-60-15	0.84	104	150	86	132	M8	35	8,400	4,200	240	480	480
WW-16-60-20	0.97	104	200	86	182	M8	35	8,400	4,200	240	690	690
WW-20-80-15	1.20	134	150	116	132	M8	44	12,800	6,400	525	670	670
WW-20-80-20	1.30	134	200	116	182	M8	44	12,800	6,400	525	990	990
WW-20-80-25	1.50	134	250	116	232	M8	44	12,800	6,400	525	1,250	1,250
WW-25-120-15	2.54	195	150	173	128	M10	55	19,200	9,600	1,250	880	880
WW-25-120-20	2.80	195	200	173	178	M10	55	19,200	9,600	1,250	1,360	1,360
WW-25-120-25	3.07	195	250	173	228	M10	55	19,200	9,600	1,250	1,840	1,840

⁹⁰ Height dimension minus the bearing clearance tolerance ⁹¹ Optionally available with manual clamp, suffix "-HKA"

Can be combined with:



WS-... WS-...-ES-FG WSX-...

Suitable liner material:



J J200 X E7 A180

drylin® W profile guides | Product Range

Assembled stainless steel guide carriages, round

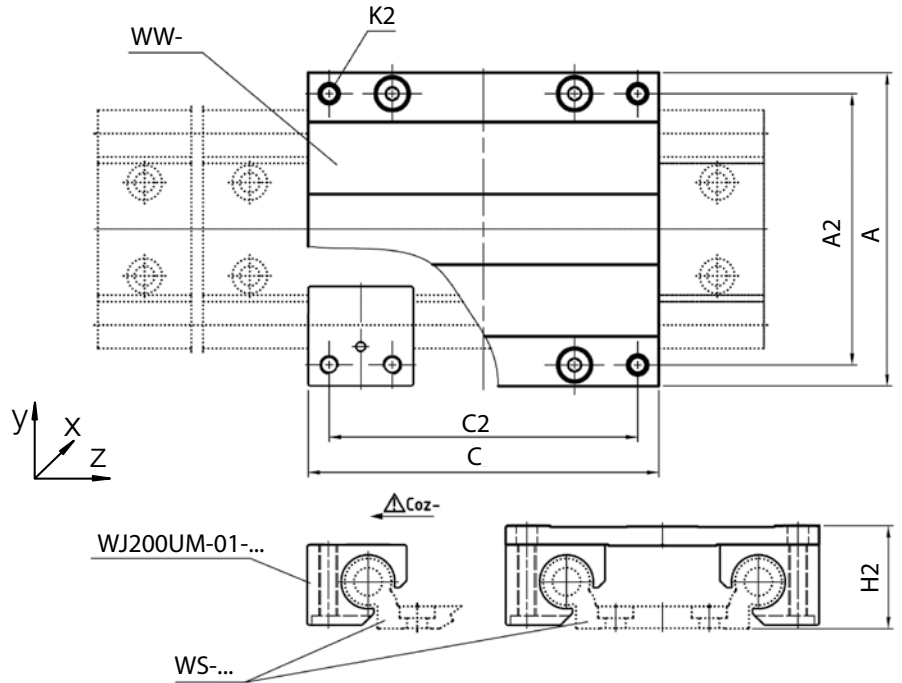

Technical data and dimensions [mm]

Part No. ⁵⁰	Weight [kg]	A		C2	K2	H2 ⁵¹	Static load capacity					
		Width	Length				±0.25	Coy	Coz	Mox	Moy	Moz
WW-10-40-10-J200-GESG-PES	0.29	73	100	60	87	M6	24	4,800	2,400	96	170	170
WW-10-40-15-J200-GESG-PES	0.34	73	150	60	137	M6	24	4,800	2,400	96	290	290
WW-10-40-20-J200-GESG-PES	0.40	73	200	60	187	M6	24	4,800	2,400	96	410	410

⁵¹ Height dimension minus the bearing clearance tolerance ⁵⁰ Optionally available with manual clamp, suffix "-HKA"

Notes

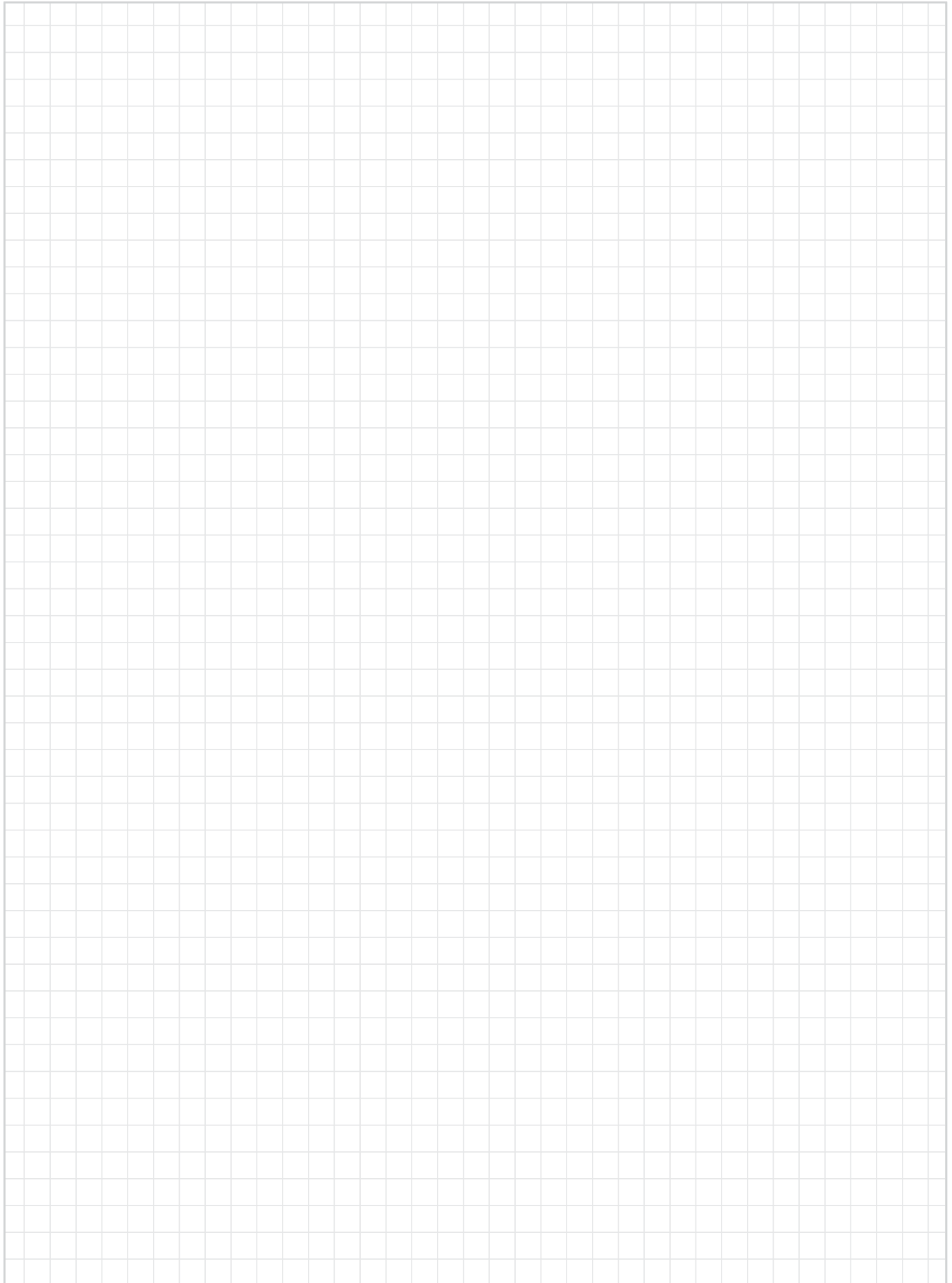

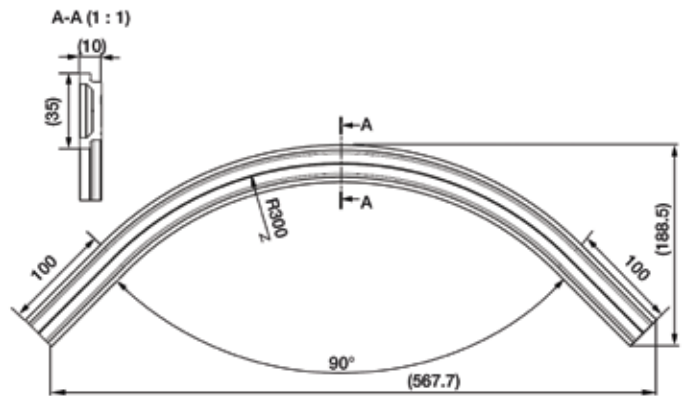
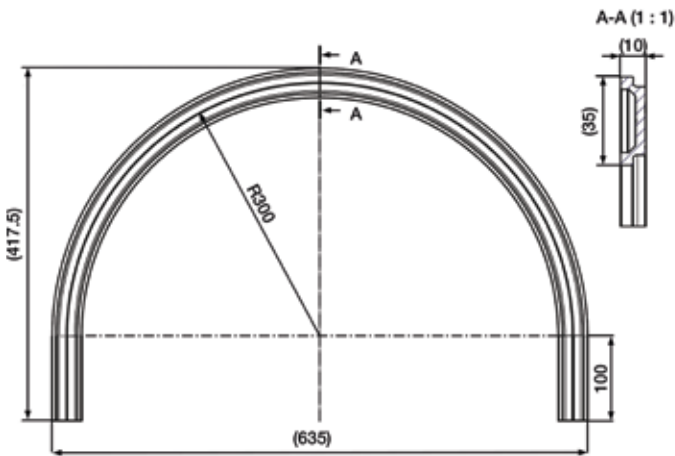
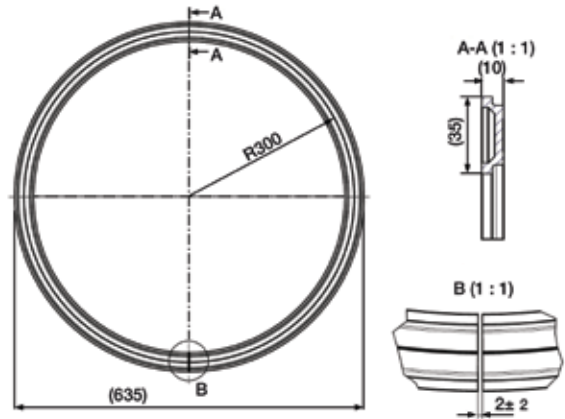

More information
▶ www.igus.com/drylin/linear-guide



Curved rail profiles
▶ Page 1096

Technical data and dimensions [mm]

Part No. ⁵⁰⁾	Matching carriage for curved rail	Design	Bend radius	End straight
WSB-06-30-RK300F ⁵⁰⁾	WWB-06-30-06-R175	Full circle	60	–
WSB-06-30-RK300HS	WWB-06-30-06-R175	Half circle	60	100
WSB-06-30-RK300QS	WWB-06-30-06-R175	Quarter circle	60	100
WSB-06-30-RK500HS	WWB-06-30-06-R400	Half circle	60	100
WSB-06-30-RK500QS	WWB-06-30-06-R400	Quarter circle	60	100

⁵⁰⁾ The F version (full circle) has a transition of 2mm (± 0.2). Due to the bending process, material displacement tolerances, which can be up to several millimeters depending on the bend direction and radius, must be taken into account.

RK: Radius curved bending

S: Straight rail ends in the case of semicircle and quarter circle

Can be combined with:



WWB-...

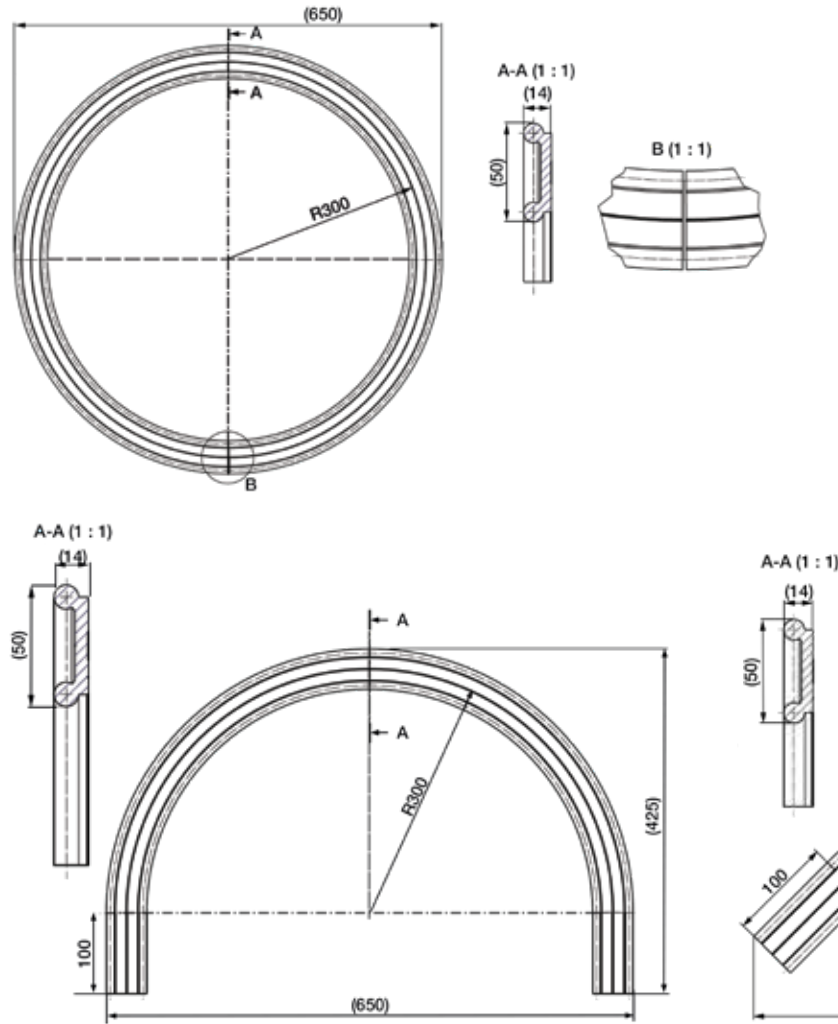

Order key

Type	Size	Option
WSB-06-30-RK300-F		
Curved rail profile		
Shaft Ø		
Profile width [mm]		
RK: Radius curved bending		
With spring pre-load		
Full circle		

Technical data and dimensions [mm]

Part No. ⁵⁰	Matching carriage for curved rail	Design	Bend radius	End straight
WSB-10-40-RK300F ⁵⁰⁾	WWB-10-40-10-R250	Full circle	60	-
WSB-10-40-RK300HS	WWB-10-40-10-R250	Half circle	60	100
WSB-10-40-RK300QS	WWB-10-40-10-R250	Quarter circle	60	100
WSB-10-40-RK500F ⁵⁰⁾	WWB-10-40-10-R400	Full circle	102	-
WSB-10-40-RK500HS	WWB-10-40-10-R400	Half circle	102	100
WSB-10-40-RK500QS	WWB-10-40-10-R400	Quarter circle	102	100

⁵⁰⁾ The F version (full circle) has a transition of 2mm (± 0.2). Due to the bending process, material displacement tolerances, which can be up to several millimeters depending on the bend direction and radius, must be taken into account.

RK: Radius curved bending

S: Straight rail ends in the case of semicircle and quarter circle



Order key

Type	Size	Option
------	------	--------

W I 3 U B P - 0 1 - 1 0 - L L Z

drylin® W	Liner material iglide® I3	Curved	Pre-load	Standard	Size	Floating bearing in y-direction
-----------	------------------------------	--------	----------	----------	------	------------------------------------

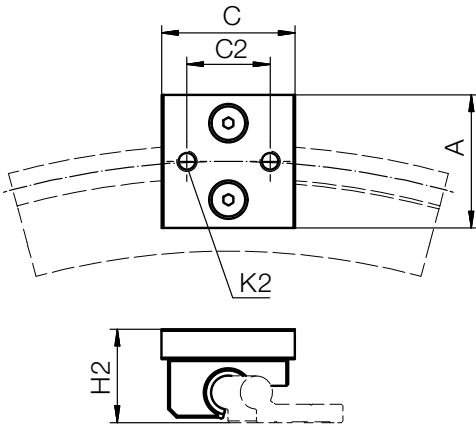

Dimensions [mm]

Part No.	Weight [g]	A	C	C2	K2	H2
W I 3 U B P - 0 1 - 1 0	50	40	40	25	M6	28
W I 3 U B P - 0 1 - 1 0 - R 3 0 0 - L L Z	44	40	40	25	M6	28
W I 3 U B P - 0 1 - 1 0 - R 5 0 0 - L L Z	44	40	40	25	M6	28
W I 3 U B P - 0 1 - 1 0 - L L Z	44	40	40	25	M6	28

Can be combined with:



WSB-...

drylin® W profile guides | Product Range

Carriage for curved rail



Order key

Type	Size	Option
WWB-10-40-10-P-HKA		
Guide carriages for curved rails	Shaft Ø	Profile width [mm]
		Carriage length [mm]
		With spring pre-load
		With manual clamp

Options:
Blank: Standard
HKA: With manual clamp

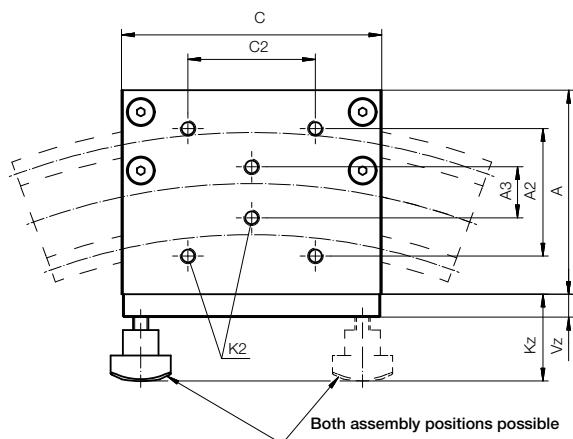

Curved rail profiles ▶ Page 1096

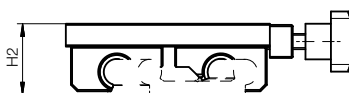

Technical data and dimensions [mm]

Part No. ⁵⁴⁾	Weight	A	C	A2	A3	C2	K2	H2	Vz	Kz
		±0.25	-0.1							
	[kg]									
WWB-06-30-06 ⁵⁴⁾	0.31	58	60	30	16	30	M4	20	9	34
WWB-06-30-06-P ⁵⁴⁾	0.31	58	60	30	16	30	M4	20	7.5	29
WWB-06-30-06-R300 ¹⁴³⁾ -P ⁵⁴⁾	0.31	58	60	30	16	30	M4	20	7.5	29
WWB-10-40-10 ⁵⁴⁾	0.35	80	102	50	20	50	M6	28	9	34
WWB-10-40-10-P ⁵⁴⁾	0.35	80	102	50	20	50	M6	28	9	34
WWB-10-40-10-R300 ¹⁴³⁾ -P ⁵⁴⁾	0.35	80	102	50	20	50	M6	28	9	34

⁵⁴⁾ Optionally available with manual clamp, suffix "-HKA"

¹⁴³⁾ Optional for 500mm radius = R500

Can be combined with:



WS-...



WS-...-ES-FG



WSB-...



More information

▶ www.igus.com/drylin/linear-guide

drylin® W profile guides | Product Range

Double rails, reduced weight, hard-anodized aluminum

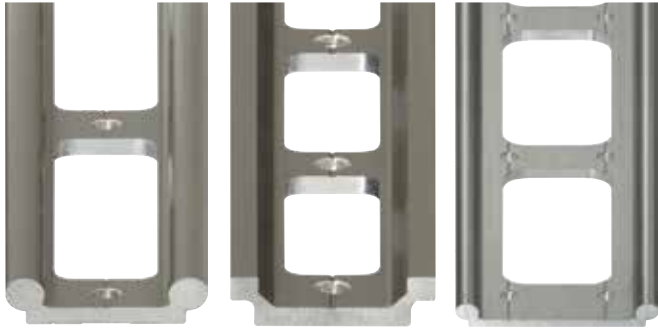

- 30% weight reduction through machined recesses
- Suitable pillow blocks and carriages made from plastic, aluminum, zinc die-casting or stainless steel

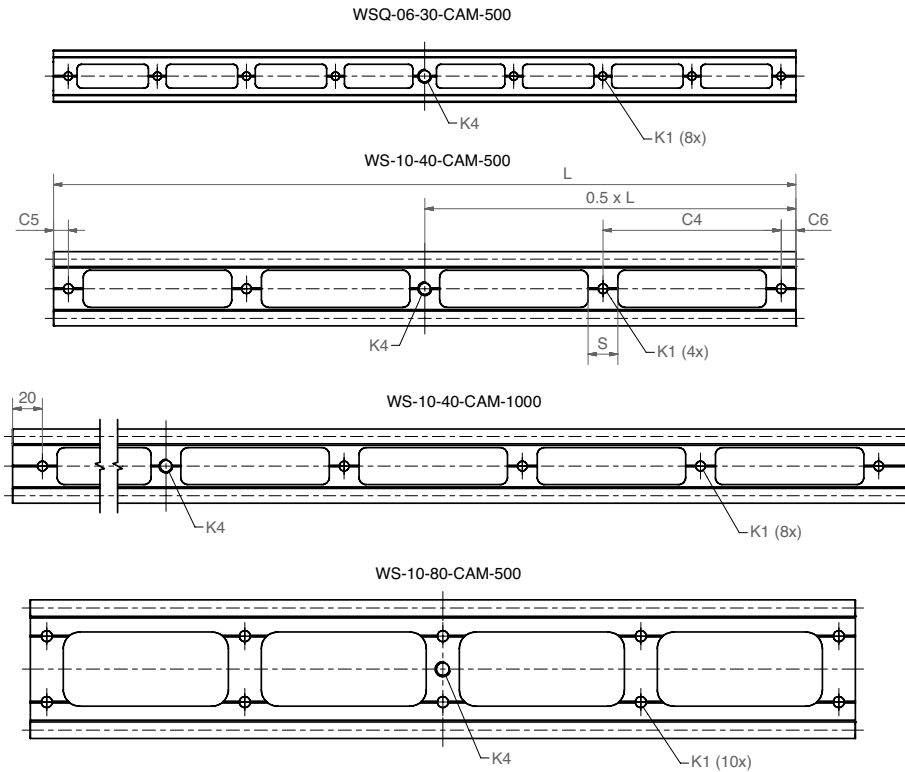

drylin® W guide rails – dimensions [mm]

Part No.	Identical profile	L	C4	C5	C6	S	K1 for screw DIN 192	K4	Weight [g]
WSQ-06-30-CAM-500	WSQ-06-30	500	60	10	10	12	M5	3/8" 16-UNC ⁶⁹	159
WS-10-40-CAM-500	WS-10-40	500	120	10	10	20	M6	3/8" 16-UNC ⁶⁹	353
WS-10-40-CAM-1000	WS-10-40	1,000	120	20	20	20	M6	3/8" 16-UNC ⁶⁹	706
WS-10-80-CAM-500	WS-10-80	500	120	10	10	20	M6	3/8" 16-UNC ⁶⁹	482

⁶⁹ * UNC = Unified National Coarse. Screw thread standard



Application example:
camera slider with standard
rail and carriage
► www.igus.com/camera

drylin® W profile guides | Product Range

Double rails/carriages for camera slider



- Wear-resistant, smooth and quiet motion
 - Adjustable brake level due to the turn-to-fit function
 - Easy and fast assembly
 - Further dimensions such as standard WS rails
- Page 1126

Technical options:

- Adjustable bearing housing ► Page 1116
- Manual clamp ► Page 1154

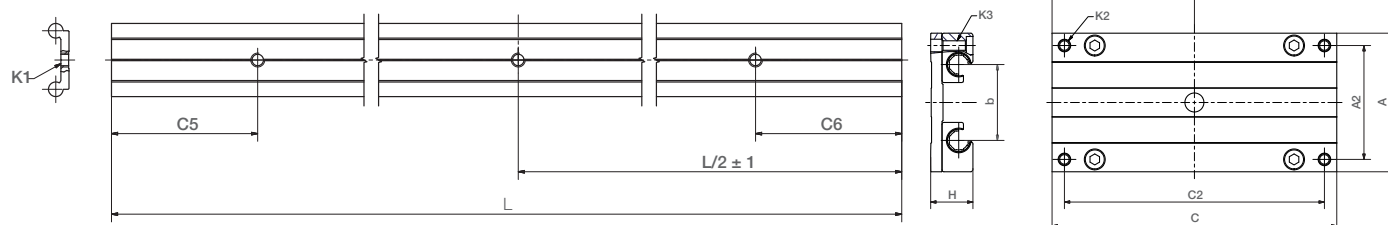

drylin® W special rails with 3 holes, 3/8" thread

Dimensions [mm]

Part No.	Size	L	C5 ± 1	C6 ± 1	Weight [kg/m]
WSQ-06-30-SL-1000	06	1,000	100	100	0.45
WSQ-06-30-SL-1500	06	1,500	100	100	0.45
WS-10-30-SL-1000	10	1,000	100	100	0.85
WS-10-30-SL-1500	10	1,500	100	100	0.85
WS-10-40-SL-1500	10	1,500	100	100	1.00
WS-10-80-SL-1000	10	1,000	100	100	1.50
WS-10-80-SL-1500	10	1,500	100	100	1.50
WS-16-60-SL-1000	16	1,000	100	100	1.96
WS-16-60-SL-1500	16	1,500	100	100	1.96
WS-20-80-SL-1000	20	1,000	100	100	3.30
WS-20-80-SL-1500	20	1,500	100	100	3.30

drylin® W complete carriage with ø10mm through hole for 3/8" thread

Dimensions [mm]

Part No.	Size	C	A	Part No.	Size	C	A
WW-06-30-06-SL	06	60	54	WW-10-80-15-SL ^{64 65}	10	150	107
WW-06-30-08-SL	06	80	54	WW-10-80-20-SL ^{64 65}	10	200	107
WW-06-30-10-SL	06	100	54	WW-16-60-10-SL ⁶⁵	16	100	104
WW-10-30-10-SL ^{64 65}	10	100	63	WW-16-60-15-SL ^{64 65}	16	150	104
WW-10-30-15-SL ^{64 65}	10	150	63	WW-16-60-20-SL ^{64 65}	16	200	104
WW-10-40-10-SL ^{64 65}	10	100	73	WW-20-80-15-SL ^{64 65}	20	150	134
WW-10-40-15-SL ^{64 65}	10	150	73	WW-20-80-20-SL ^{64 65}	20	200	134
WW-10-40-20-SL ^{64 65}	10	200	73	WW-20-80-25-SL ^{64 65}	20	250	134
WW-10-80-10-SL ^{64 65}	10	100	107				

⁶⁴ Optionally available with manual clamp, suffix "-HKA"

⁶⁵ Optional with adjustable "Turn-To-Fit" bearing (Order example: WWE-...)

drylin® W profile guides | Product Range

Hybrid slider carriages with four double roller bearings



Order key



Ø 10mm through hole for
3/8" thread for cameras

Type	Dimensions	Design
WWH-21-10-40-10-SL		
drylin® W	Hybrid carriages	Double roller bearing
	Installation size	Carriage length [mm]
		Slider carriage



Optionally available with
manual clamp,
suffix "-HKA"

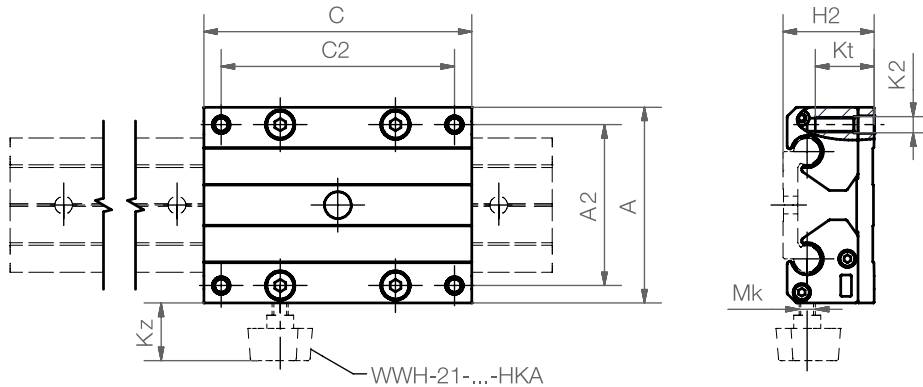

Technical data and dimensions [mm]

Part No.	Weight [kg]	A Width	C Length	A2	C2	K2	Kt	H2	Static load capacity
									Coy [N]
WWH-21-10-40-10-SL	0.59	73	100	60	87	M6	21	34	1,400
WWH-21-10-40-15-SL	0.64	73	150	60	137	M6	21	34	1,400
WWH-21-10-40-20-SL	0.70	73	200	60	187	M6	21	34	1,400
WWH-21-10-80-10-SL	0.64	107	100	94	87	M6	21	34	1,400
WWH-21-10-80-15-SL	0.72	107	150	94	137	M6	21	34	1,400
WWH-21-10-80-20-SL	0.80	107	200	94	187	M6	21	34	1,400
WWH-21-16-60-10-SL	1.31	104	100	86	82	M8	29	49	2,400
WWH-21-16-60-15-SL	1.44	104	150	86	132	M8	29	49	2,400
WWH-21-16-60-20-SL	1.57	104	200	86	182	M8	29	49	2,400
WWH-21-20-80-15-SL	1.72	134	150	116	132	M8	24	57	3,360
WWH-21-20-80-20-SL	1.82	134	200	116	182	M8	24	57	3,360
WWH-21-20-80-25-SL	2.02	134	250	116	232	M8	24	57	3,360

Can be combined with:



WS-20-80 WS-...-ES-FG WSX-...

Can be combined with camera slider rails

► Page 1136

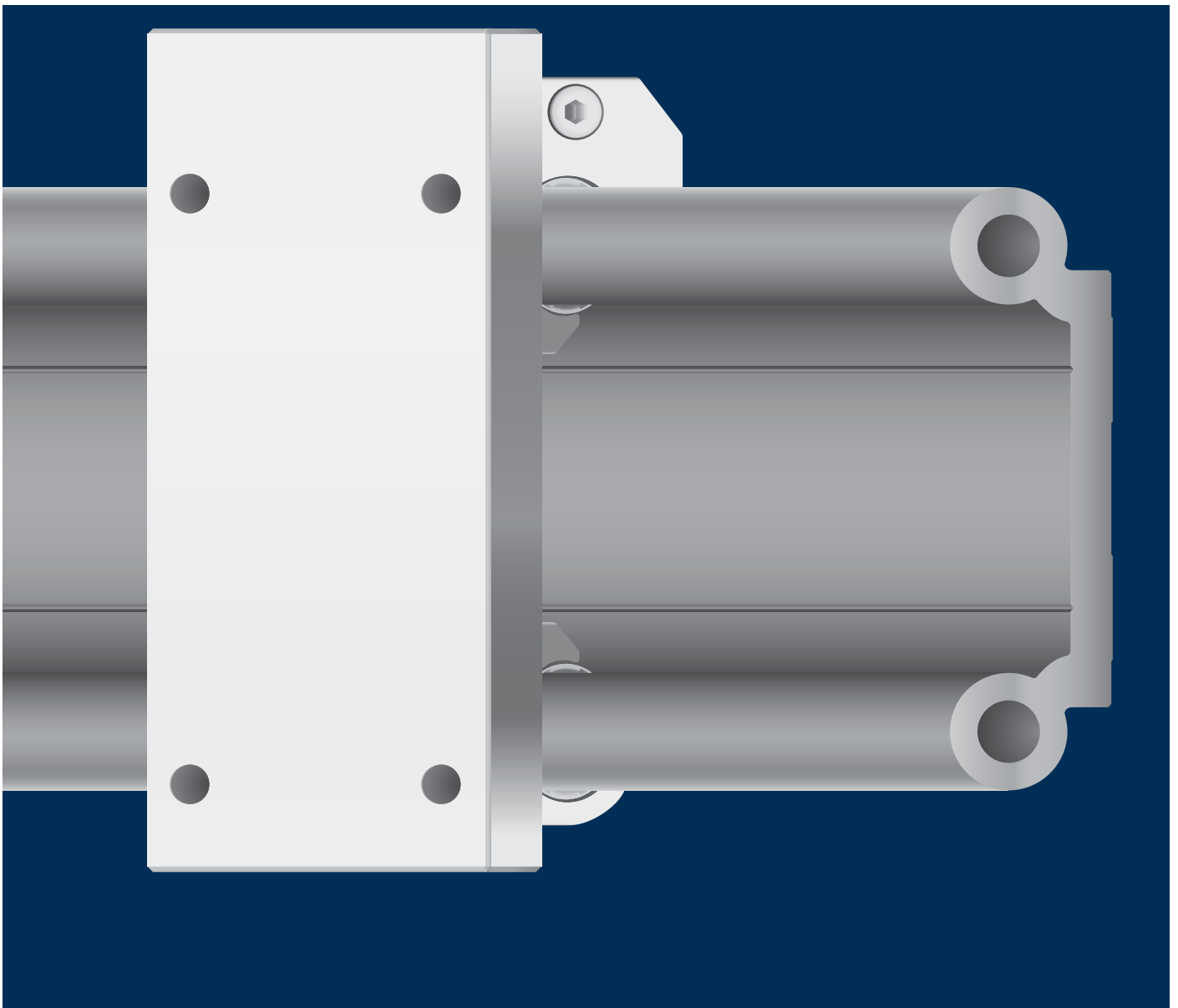

drylin[®] linear technology – drylin[®] W hybrid roller bearings

Self-lubricating roll and slide

Low drive force

For manual adjustment

Suitable for radial loads

Single bearings and complete carriages



drylin® W hybrid roller bearings | Advantages

Hybrid roller bearings from the drylin® W linear construction kit

Combined sliding and rolling for low driving forces

drylin® hybrid roller bearings offer a unique self-lubricating combination of plain and roller bearings. The integrated rollers achieve low driving forces, while the sliding effect simultaneously protect against radial loads. This makes drylin® hybrid roller bearings ideal for manual adjustments in door applications (e.g. machine doors, safety doors), but also in mobile control panels. The efficient design using plastics with zinc die-casting also cuts costs. hybrid roller bearings can be used on various hard-anodized aluminum profiles from the drylin® W linear construction kit.

- Smooth operation
- Low-profile
- Offset and abuse forces are easily absorbed by sliding elements
- Location on rail ensures reliability
- Matching guide rails made from hard-anodized aluminum
- Low driving force required
- Cost-effective

Typical application areas

- Machine doors
- Safety doors
- Operator panels



Available from stock

Detailed information about delivery time online.



Price breaks online

No minimum order value. No minimum order quantity.



Service life calculation

► www.igus.com/drylin-expert



Tightening torque for drylin® metallic screws

► Page 1097

drylin® W rail made from hard-anodized aluminum

Housing made of robust zinc die-casting or durable stainless steel

Self-lubricating and quiet operation

Compact aluminum carriage with assembled drylin® W hybrid roller bearing

Liners made from iglide® high-performance polymers

Can be combined with drylin® W linear profile rails

Easy to move thanks to the combination of rolling and sliding

Single and double rails

drylin® W hybrid roller bearings | Product overview

Slide and roll



Hybrid roller bearing rail

- Ideal for flat structures
- Geometry optimized for hybrid roller bearings
- Low-profile design with wide support

► Page 1144



Hybrid roller bearings with double rollers

- Low coefficient of rolling friction is still maintained with deviating load directions
- Increased load capacity
- Variable installation position

► Page 1145



Hybrid roller bearing with single roller

- Self-lubricating due to bearing supported plastic roller
- Low displacement force
- Can be combined with drylin® W single and double rails

► Page 1146 / 1148



Hybrid roller bearing with double rollers

- Low coefficient of rolling friction is still maintained with deviated load directions
- Increased load capacity
- Variable bearing removed, but the housing is now available in corrosion-resistant stainless steel

► Page 1147 / 1148



Complete carriages WWR

- Complete carriage for lateral applications
- Guidance via a double rail without support
- Also available as a short, compact carriage for variable multi-carriage solution

► Page 1149



Complete carriages WWH

- Complete carriage with 4 integrated hybrid roller bearings
- For horizontal installation
- Variable carriage lengths and widths

► Page 1150



Suitable rail profiles

► From Page 1112



Camera slider

► From Page 1138

drylin® W hybrid roller bearings | Application examples



The smooth, quiet operation and the enormous cost advantages are obtained by the use of the drylin® linear bearings on the hard-anodized guide shaft to guide the doors of machine tools.



Adjustment control panel unit



Camera stand with drylin® W hybrid roller bearings for far smoother running. Vertical movements are now also possible.

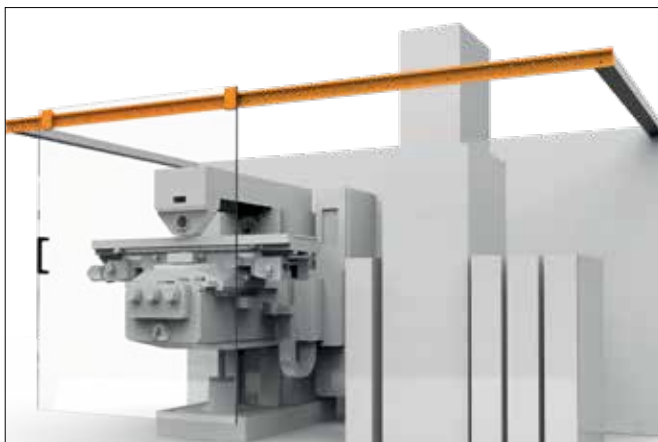

The new drylin® W hybrid carriage with "door opener" function.



drylin® W hybrid roller bearings in combination with drylin® W profile guides offer optimum opportunities to construct dollies and sliders.

drylin® W hybrid roller bearings | Technical data

drylin® W hybrid roller bearings type 01

The drylin® W hybrid roller bearings from the WJRM-01-... type series are each equipped with a bearing-supported plastic roller. The bearing housing is available in three installation sizes and can be used with drylin® W single or double shaft rails in two installation positions. The hybrid roller bearing should be installed so that the load capacity is applied normal to the roller. Different load directions are possible but causes higher displacement forces.

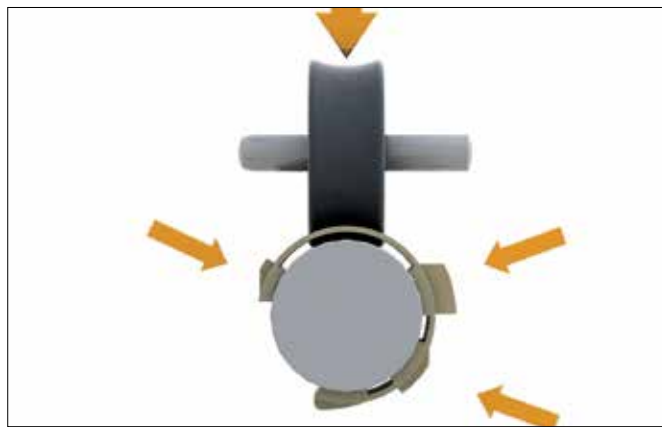

Forces absorbed by hybrid roller bearing

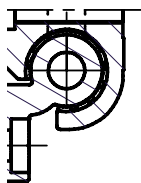

Installation position 01

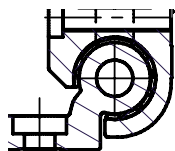

Installation position 02

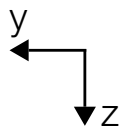

Installation position WJRM-01-...

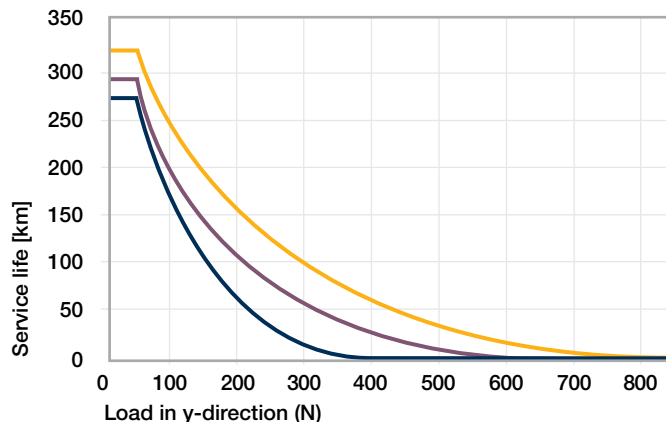

■ WJRM-01-10 ■ WJRM-01-16 ■ WJRM-01-20

drylin® W hybrid roller bearings type 21

The drylin® W hybrid roller bearings in the WJRM-21-... type series are each equipped with two bearing-supported plastic rollers at an angle of 70° or 80°. Available in three installation sizes, they can be combined with drylin® W single and double rails. The double roller bearings offer a higher load capacity than with a vertical bearing load on the installation area (y-direction). The low coefficient of rolling friction is still maintained with load directions that slightly deviate from this.

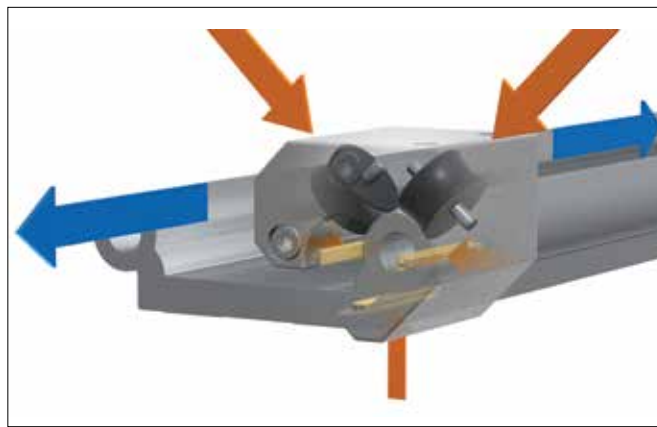

Hybrid double roller bearing applicable force absorption

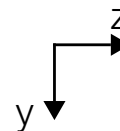
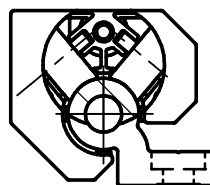

Installation position WJRM-21-...

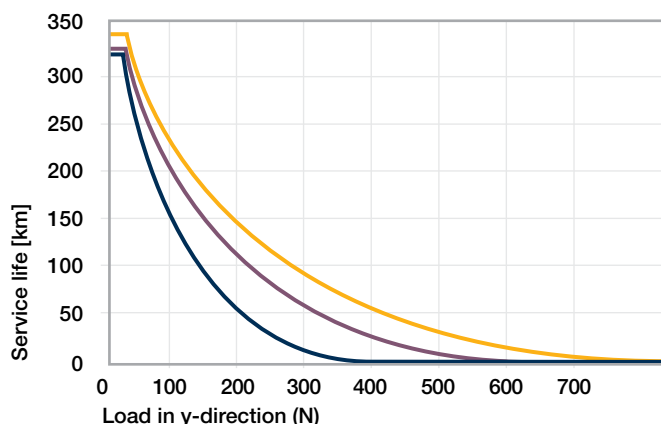

■ WJRM-21-10 ■ WJRM-21-16 ■ WJRM-21-20

drylin® W hybrid roller bearings | Product Range

Hybrid rail for lateral installation



Order key

Type Size
WSR-10-120-4000

Hybrid lateral rail	Shaft Ø	Rail width [mm]	Rail length [mm]
---------------------	---------	-----------------	------------------

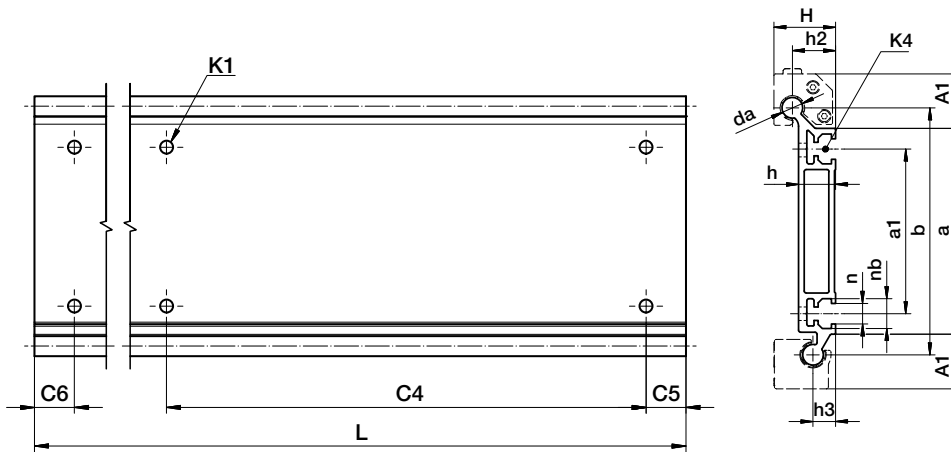

Dimensions [mm]

Part No.	H	da	L	a	A1	b	h	h2	h3	a1	n	nb	C4	C5 = C6	
	±0.25	-0.1	Max.	±0.6										Min.	Max.
WSR-10-120	30	10	4,000	100	26.5	120	18	21	11	80	10	14.5	240	20	199.5
WSR-10-120 no holes	30	10	4,000	100	26.5	120	18	21	11	80	10	14.5	-	-	-

Technical data [mm]

Part No.	Geometrical moment of inertia		Moment of resistance		K1 for screw	K4 for slot nut	Weight
	ly	lz	Wby	Wbz			
	[mm ⁴]	[mm ⁴]	[mm ³]	[mm ³]			
WSR-10-120	1,443,000	38,700	22,000	2,600	M6	-	2.58
WSR-10-120 no holes	1,443,000	38,700	22,000	2,600	-	MSX-B-0001-M6	2.58

Can be combined with:



WJRM-31...



WJRM-41...

1144 Lifetime calculation, configuration and more ► www.igus.com/drylinW-hybrid

drylin® W hybrid roller bearings | Product Range

Hybrid roller bearing for lateral rail

drylin® W
hybrid roller
bearings



Order key

Type

Size

WJRM-31-10

Hybrid roller bearings

Double roller bearing

Size 10

Options:

31: Single roller bearing, bottom assembly for better support

41: Double roller bearing, top assembly for better force absorption

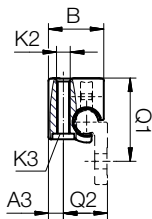

WJRM-31
Installation position 1

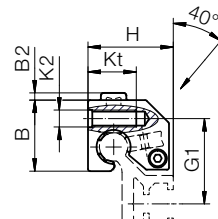
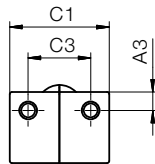

WJRM-41



Suitable mounting plate

► Page 1152



Dimensions [mm]

Part No.	A3	B	B2	C1	C3	H	G1	K2 for thread	K3 for screw	Q1	Q2	kt
WJRM-31-10	6.5	24	–	35	22	28	27	M6	M5	36	19	16
WJRM-41-16	6.5	24	2.5	35	22	30	30	M6	M5	–	–	–

Technical data [mm]

Part No.	Static load capacity	Dyn. load capacity Cz+ at total running distance [km]				F · v	Weight
	Co [N]	10 [N]	100 [N]	200 [N]	Max. [N · m/s]	[g]	
WJRM-31-10	250	250	90	50	< 0.1	91	
WJRM-41-16	250	250	90	50	< 0.1	97	

Can be combined with:



WSR...

drylin® W hybrid roller bearings | Product Range

Hybrid roller bearings with a plain bearing-supported plastic roller

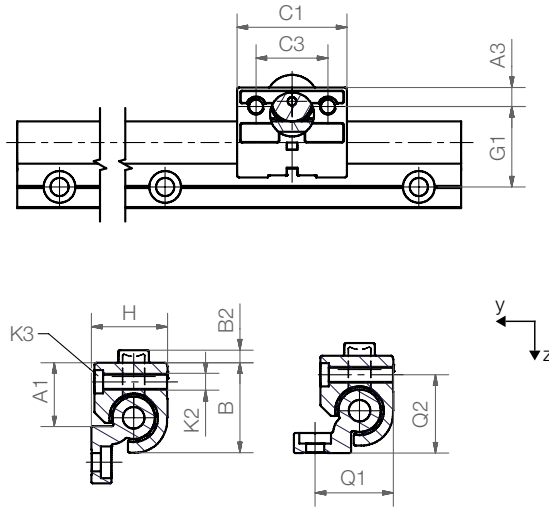

Installation position 01

Installation position 02



Order key

Type Size

WJRM-01-10

Hybrid roller bearings

Single roller bearing

Size 10



Installation position 02 in installation size $\varnothing 10$ when using a WJRM-02-10 hybrid roller bearing

Technical data and dimensions [mm]

Part No.	Static load capacity C_0	Dyn. load capacity C_{z+} at total running distance [km]			F · v
		10	100	200	
	[N]	[N]	[N]	[N]	Max. [N · m/s]
WJRM-01-10 ⁷⁾	250	250	90	50	50
WJRM-01-16	400	400	140	70	80
WJRM-01-20	550	550	200	100	80

Part No.	Coefficient of friction in z-direction	Weight	A1	A3	B	B2	C1	C3	G1	H	K2 for K3 for thread screw		Q1	Q2
											[μ]	[g]		
WJRM-01-10 ⁷⁾	< 0.1	46	16.5	6.5	26	2.5	35	22	27	18	M6	M5	-	-
WJRM-01-16	< 0.1	131	25	9	34.5	5	48	30	33	27	M8	M6	32	28
WJRM-01-20	< 0.1	232	30	9	42.5	6	52	34	38	36	M8	M6	37	37

⁷⁾ Deviating from WJRM-02-10, available with an expanded opening angle for installation position 02

Can be combined with:



WS-...



WS-...-ES-FG-...



WS-...



WS-...-ES-FG



WSX-...

drylin® W hybrid roller bearings | Product Range

Hybrid roller bearings with double angled plastic rollers

drylin® W
hybrid roller
bearings

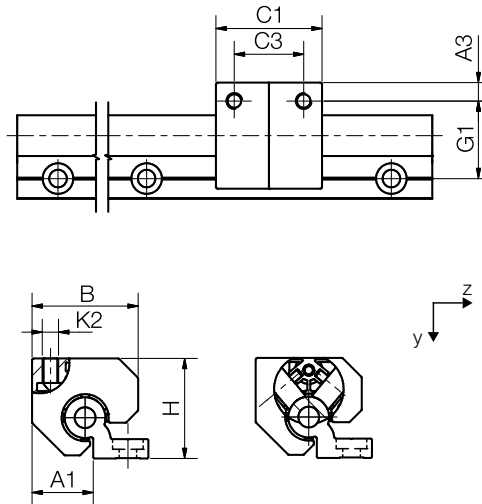

Order key

Type Size

WJRM-21-10

Hybrid roller bearings

Double roller bearing

Size 10

Technical data and dimensions [mm]

Part No.	Static load capacity C_0	Dyn. load capacity C_{z+} at total running distance [km]			F · v Max. [N · m/s]
		10	100	200	
	[N]	[N]	[N]	[N]	
WJRM-21-10	350	350	125	70	50
WJRM-21-16	600	600	210	105	80
WJRM-21-20	840	840	300	150	80

Part No.	Coefficient of friction in y-direction	Weight [g]	A1	A3	B	C1	C3	G1	H	K2 for screw
WJRM-21-10	< 0.1	115	16.5	6.5	31	35	22	27	28	M6
WJRM-21-16	< 0.1	250	25	9	44	48	30	33	41	M8
WJRM-21-20	< 0.1	320	30	9	52	52	34	38	49	M8

WJRM-21-10 and WJRM-21-16: 70° angle between the rollers / WJRM-21-20: 80° angle between the rollers



Optionally available with manual clamp, suffix "-HKA"



Can be combined with:



WS-...



WS-...-ES-FG-...



WS-...



WS-...-ES-FG



WSX-...

drylin® W hybrid roller bearings | Product Range

Hybrid roller bearing made from stainless steel

WJRM-01 with single roller

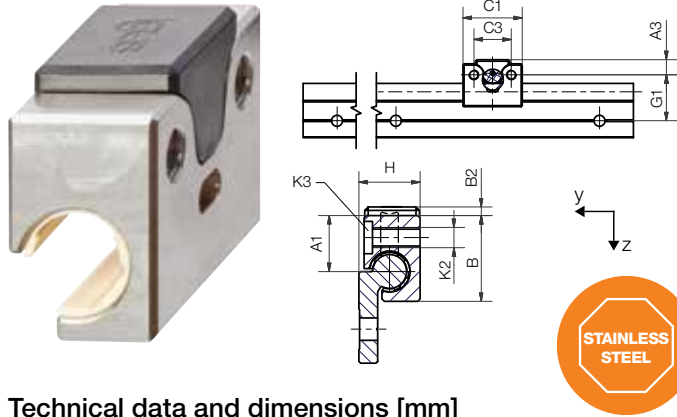

Order key

Type	Size	Material
WJRM-01-10 - ES		
Hybrid roller bearing	Single roller bearing	Size 10
		Stainless steel

Material
ES: Stainless steel (AISI 316Ti)
ES-FG: Stainless steel precision casting AISI 316
AL: Aluminum

Technical data and dimensions [mm]

Part No.	Static load capacity Co	Dyn. load capacity Cz+ at total running distance [km]			F · v Max.
		10	100	200	
	[N]	[N]	[N]	[N]	[N · m/s]
WJRM-01-10-ES-FG	250	250	90	50	50
WJRM-01-10-AL	250	250	90	50	50

Part No.	coefficient of friction in		Weight	A1	A3	B	B2	C1	C3	G1	H	K2	K3 for screw
	z-direction	y-direction											
	[μ]	[μ]	[g]										
WJRM-01-10-ES-FG	< 0.1	-	57	16.5	6.5	26	2.5	35	22	27	18	M6	M5
WJRM-01-10-AL	< 0.1	-	18	16.5	6.5	26	2.5	35	22	27	18	M6	M5

WJRM-21 with double roller

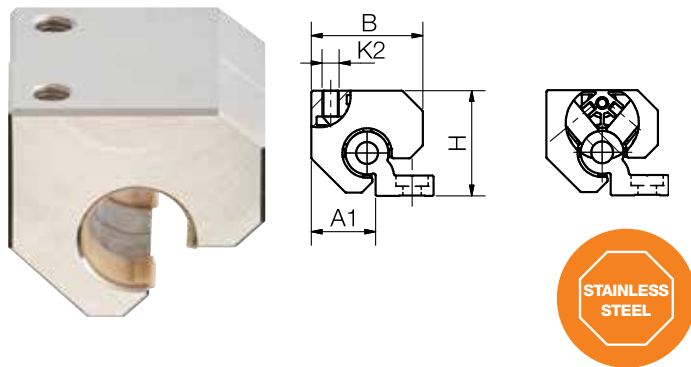

Order key

Type	Size	Material
WJRM-21-20 - ES		
Hybrid roller bearing	Double roller bearing	Size 20
		Stainless steel

Material
ES: Stainless steel (AISI 316Ti)
ES-FG: Stainless steel precision casting AISI 316

Technical data and dimensions [mm]

Part No.	Static load capacity Co	Dyn. load capacity Cz+ at total running distance [km]			F · v Max.
		10	100	200	
	[N]	[N]	[N]	[N]	[N · m/s]
WJRM-21-20-ES-FG	840	840	300	150	80

Part No.	coefficient of friction in		Weight	A1	A3	B	C1	C3	G1	H	K2	K3 for screw
	z-direction	y-direction										
	[μ]	[μ]	[g]									
WJRM-21-20-ES-FG	-	< 0.1	504	30	9	52	52	34	38	49	M8	M5

drylin® W hybrid roller bearings | Product Range

Hybrid carriages for lateral installation



Order key

Type Size Option

WWR-21-80 - 01

drylin® W	Hybrid carriages	Double roller bearing	Installation size	Compact
-----------	------------------	-----------------------	-------------------	----------------

Options:

01: Carriage, short design

15: Carriage, long design

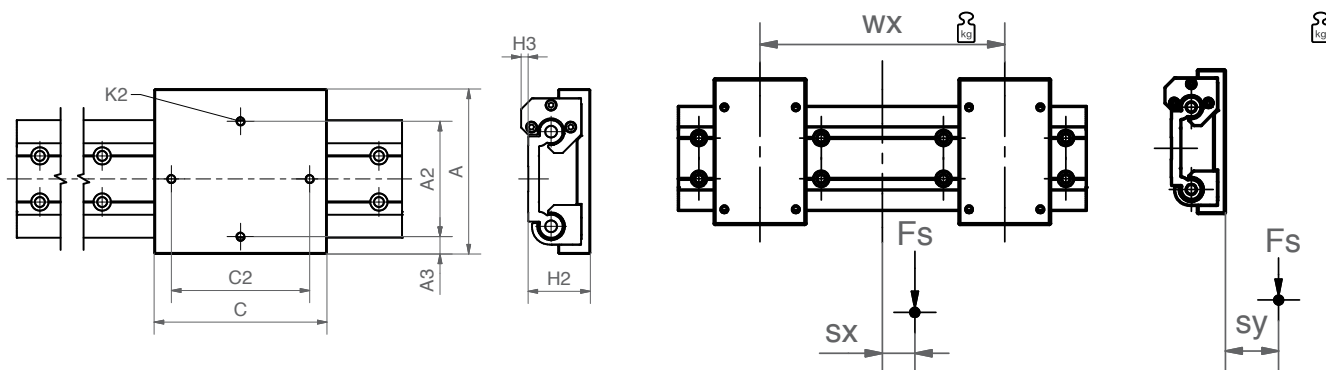

Technical data and dimensions [mm]

Part No.	A	C	A2	C2	K2	H2	A3	H3	sx min.	sx max.	sy min.	sy max.
	Width	Length				±0.17						
WWR-21-80-01	143	90	100	70	M8	54	15	6	-49	+49	-34	+34
WWR-21-80-15	143	150	100	120	M8	54	15	6	-wx/2	+wx/2	-34	+34



Order example:

WWR-21-80-01 = Assembled single hybrid carriage as a "door opener" with two single roller hybrid bearings and two double roller hybrid bearings

Can be combined with:



WS-20-80 WS-...-ES-FG WSX-...

drylin® W hybrid roller bearings | Product Range

Hybrid carriages with four double roller bearings



Order key

Type	Dimensions
WWH-21-10-40-10	
drylin® W	Carriage length [mm]
Hybrid carriages	
Double roller bearing	
Installation size	

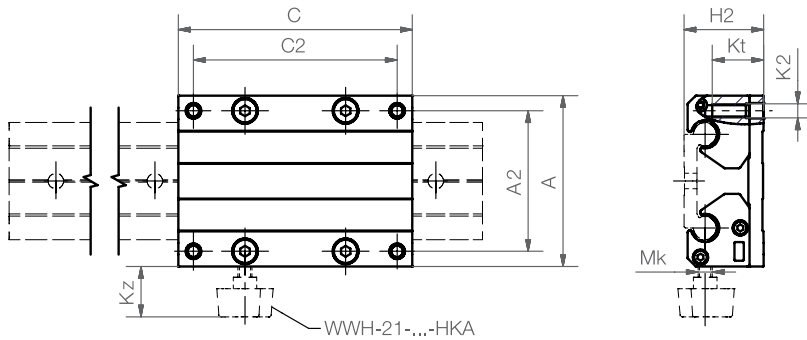

i Optionally available with manual clamp, suffix "-HKA"

Technical data and dimensions [mm]

Part No.	Weight [kg]	Dimensions		A2	C2	K2	Kt	H2	Static load capacity Coy [N]
		Width A	Length C						
WWH-21-10-40-10	0.59	73	100	60	87	M6	21	34	1,400
WWH-21-10-40-15	0.64	73	150	60	137	M6	21	34	1,400
WWH-21-10-40-20	0.70	73	200	60	187	M6	21	34	1,400
WWH-21-10-80-10	0.64	107	100	94	87	M6	21	34	1,400
WWH-21-10-80-15	0.72	107	150	94	137	M6	21	34	1,400
WWH-21-10-80-20	0.80	107	200	94	187	M6	21	34	1,400
WWH-21-10-120-10	0.71	153	100	140	87	M6	21	34	1,400
WWH-21-10-120-15	0.84	153	150	140	137	M6	21	34	1,400
WWH-21-10-120-20	0.96	153	200	140	187	M6	21	34	1,400
WWH-21-16-60-10	1.31	104	100	86	82	M8	29	49	2,400
WWH-21-16-60-15	1.44	104	150	86	132	M8	29	49	2,400
WWH-21-16-60-20	1.57	104	200	86	182	M8	29	49	2,400
WWH-21-20-80-15	1.72	134	150	116	132	M8	24	57	3,360
WWH-21-20-80-20	1.82	134	200	116	182	M8	24	57	3,360
WWH-21-20-80-25	2.02	134	250	116	232	M8	24	57	3,360

Can be combined with:



WS-20-80 WS-...-ES-FG WSX-...

drylin® W hybrid roller bearings | Product Range

Hybrid carriages with four single roller bearings for horizontal installation

drylin® W
hybrid roller
bearings



Order key

Type

Dimensions

WWH-10-40-10

drylin® W

Hybrid carriages

Installation size

Carriage length [mm]

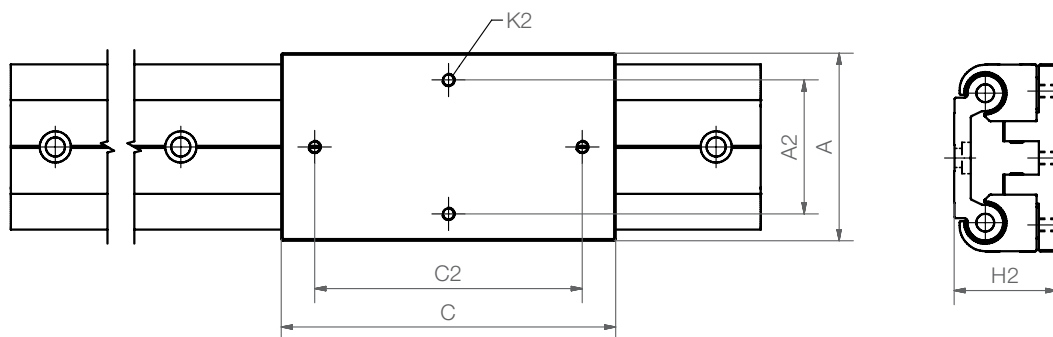

Technical data and dimensions [mm]

Part No.	Weight [kg]	A	A2	C	C2	K2	H2	Stat. load capacity				
								Coy [N]	Coz [N]	Mox [Nm]	Moy [Nm]	Moz [Nm]
WWH-10-40-10	0.35	58	40	100	80	M5	34	1,000	1,000	20	16	32
WWH-16-60-15	0.96	84	60	150	120	M6	46	1,600	1,600	45	38	77
WWH-20-80-25	1.78	114	90	250	220	M6	55	2,200	2,200	90	435	435

Can be combined with:



WS-...



WS-...-ES-FG



WSX-...



3D-CAD files, prices and delivery time ► www.igus.com/drylinW-hybrid

1151

drylin® W hybrid roller bearings | Product Range

Carriage plates for drylin® W hybrid roller bearings

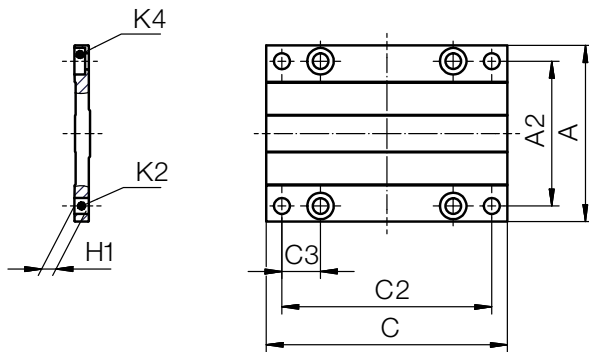

With four pillow blocks and the mounting plate, a linear carriage can be installed in less than a minute. Mounting plates are available in 3 lengths in each installation size and width.

- Robust corrosion-resistant anodized aluminum
- A variety of combinations of liners/bearings/slide plates are possible, also with manual clamp
- Required combination bearing and mounting plate also available pre-assembled



Modular system:

Can be combined with the complete drylin® linear bearing product range. 4 screws included in delivery

Technical data and dimensions [mm]

Part No.	C	A	H1	A2	K2	Mounting screws included
WWYR-10-30-08-AL	80	63	6.5	50	M6	M6
WWYR-10-30-10-AL	100	63	6.5	50	M6	M6
WWYR-10-30-15-AL	150	63	6.5	50	M6	M6
WWYR-10-40-10-AL	100	73	6.5	60	M6	M6
WWYR-10-40-15-AL	150	73	6.5	60	M6	M6
WWYR-10-40-20-AL	200	73	6.5	60	M6	M6
WWYR-10-80-10-AL	100	107	6.5	94	M6	M6
WWYR-10-80-15-AL	150	107	6.5	94	M6	M6
WWYR-10-80-20-AL	200	107	6.5	94	M6	M6
WWYR-10-120-10-AL	100	153	6.5	140	M6	M6
WWYR-10-120-15-AL	150	153	6.5	140	M6	M6
WWYR-10-120-20-AL	200	153	6.5	140	M6	M6
WWYR-16-60-10-AL	100	104	8.5	86	M8	M8
WWYR-16-60-15-AL	150	104	8.5	86	M8	M8
WWYR-16-60-20-AL	200	104	8.5	86	M8	M8
WWYR-20-80-15-AL	150	134	8.5	116	M8	M8
WWYR-20-80-20-AL	200	134	8.5	116	M8	M8
WWYR-20-80-25-AL	250	134	8.5	116	M8	M8

Suitable for rails ► Page 1126, 1127, 1144

Suitable for bearings ► Page 1145, 1146, 1147, 1148



Available from stock

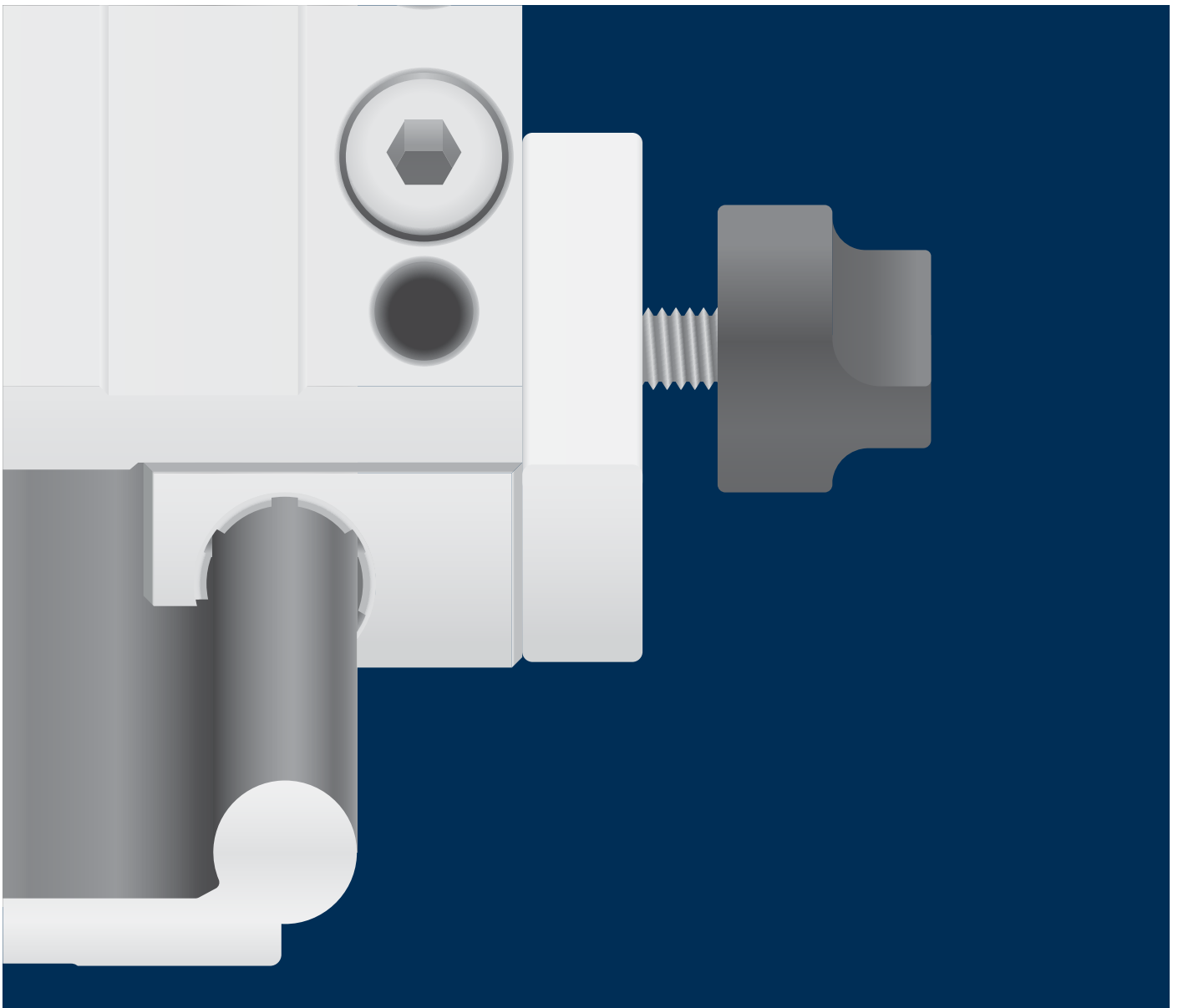

drylin® linear technology – Accessories

Manual clamps

Liners

End caps

Slot nuts

Clamps



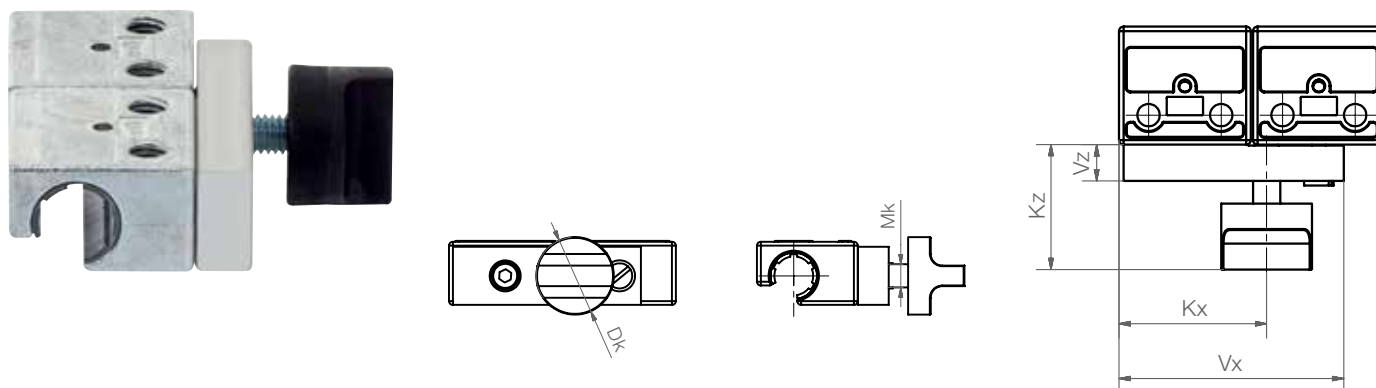

Technical data and dimensions [mm]

Part No.	Mk	Vx	Kx	Vz	Kz	Dk	Min. holding force ⁶⁷⁾	Min. tightening torque
WHKA-10 ⁶⁸⁾	M6	50	33	8	28	20	30N	0.8Nm
WHKA-16 ⁶⁸⁾	M8	72	41	10	31	28	60N	1.5Nm
WHKA-20 ⁶⁸⁾	M8	90	62	10	31	28	70N	1.5Nm
WHKA-25 ⁶⁸⁾	M8	96	65	12	31	28	70N	1.5Nm

⁶⁷⁾ Condition: dry rail surface

⁶⁸⁾ The manual clamp is also available assembled as a complete carriage (suffix "-HKA", order example: WW-10-40-10-HKA). Dimensions complete carriage WWQ ► Page 1124

Accessories: aluminum manual clamp



Technical data and dimensions [mm]

Part No.	Mk	Vx	Kx	Vz	Kz	Dk	Min. holding force ⁶⁷⁾	Min. tightening torque
WHKA-10-AL ⁶⁸⁾	M6	50	33	8	28	20	30N	0.8Nm
WHKA-16-AL ⁶⁸⁾	M8	72	41	10	31	28	60N	1.5Nm
WHKA-20-AL ⁶⁸⁾	M8	90	62	10	31	28	70N	1.5Nm
WHKA-25-AL ⁶⁸⁾	M8	96	65	12	31	28	70N	1.5Nm

⁶⁷⁾ Condition: dry rail surface

⁶⁸⁾ The manual clamp is also available assembled as a complete carriage (suffix "-AL-HKA", order example: WW-10-40-10-HKA). Dimensions complete carriage WWQ ► Page 1124

drylin® W profile guides | Product Range

Accessories: Manual clamp for square rails

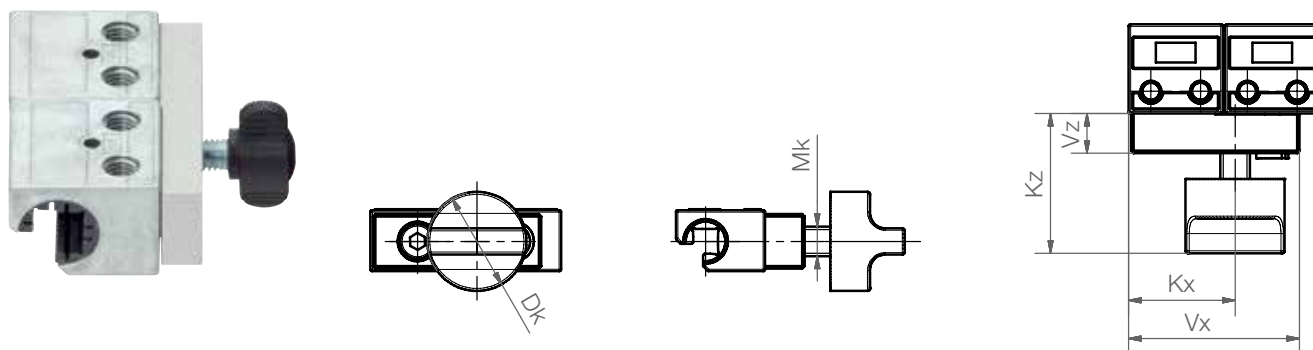

Technical data and dimensions [mm]

Part No.	Mk	Vx	Kx	Vz	Kz	Dk	Min. holding force ⁶⁷⁾	Min. tightening torque
WHKAQ-06 ¹³³⁾ 137)	M6	34.5	21.5	8	28	20	30N	0.8Nm
WHKAQ-10 ¹³⁷⁾	M6	50	33	8	28	20	30N	0.8Nm
WHKAQ-16 ¹³⁷⁾	M8	72	41	10	31	28	60N	1.5Nm
WHKAQ-20 ¹³⁷⁾	M8	90	62	10	31	28	70N	1.5Nm

⁶⁷⁾ Condition: dry rail surface

¹³³⁾ Aluminum version available, suffix "-AL"

¹³⁷⁾ The manual clamp is also available assembled as a complete carriage (suffix "-HKAQ", order example: WW-06-30-06-HKAQ). Dimensions complete carriage WWQ ► Page 1124

Accessories: Manual clamp for higher holding forces

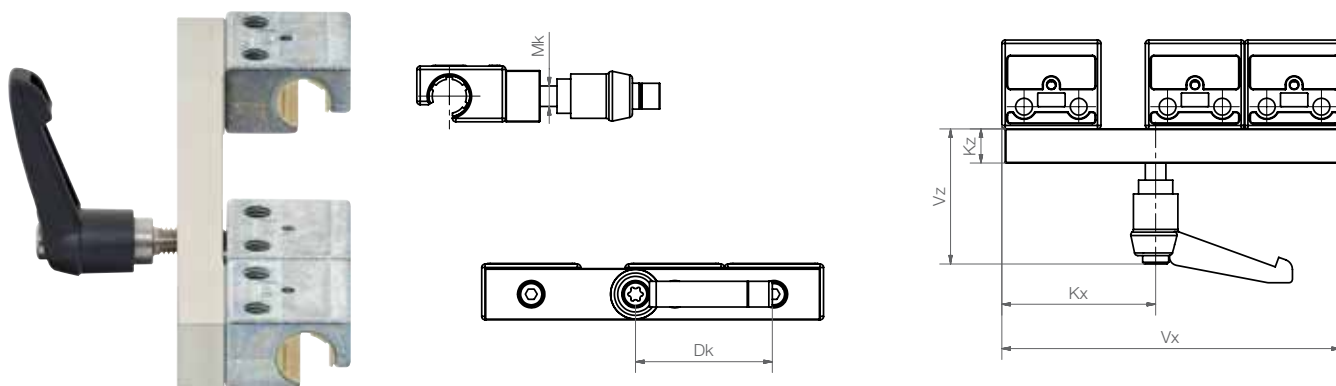

Technical data and dimensions [mm]

Part No.	Mk	Vx	Kx	Vz	Kz	Dk	Min. holding force ⁶⁷⁾	Min. tightening torque
WHKD-1010 ⁶⁹⁾	M6	100	45	40	10	40	70N	2.5Nm
WHKD-1015 ⁶⁹⁾	M6	150	95	40	10	40	70N	2.5Nm
WHKD-1615 ⁶⁹⁾	M8	150	81	40	12	40	90N	3.5Nm
WHKD-1620 ⁶⁹⁾	M8	200	131	40	12	40	90N	3.5Nm
WHKD-2015 ⁶⁹⁾	M8	150	63	40	12	40	90N	3.5Nm
WHKD-2020 ⁶⁹⁾	M8	200	113	40	12	40	90N	3.5Nm

⁶⁷⁾ Condition: dry rail surface

⁶⁹⁾ The manual clamp is also available assembled as a complete carriage (suffix "-HKA", order example: WW-10-40-10-HKD). Dimensions complete carriage WW ► Page 1124

drylin® W profile guides | Product Range

Accessories: Manual clamp for drylin® W hybrid roller bearings



Order key

Type	Size	Material	Option
WJRM-21-10 -			HKA*
Hybrid roller bearing	Single roller bearing	Size 10	Stainless steel
			Hand Clamp

Material

Blank: standard Zinc

ES-FG:

Stainless steel precision casting AISI 316

AL: Aluminum

Option:

*HKA Hand clamp - Contact igus® for availability

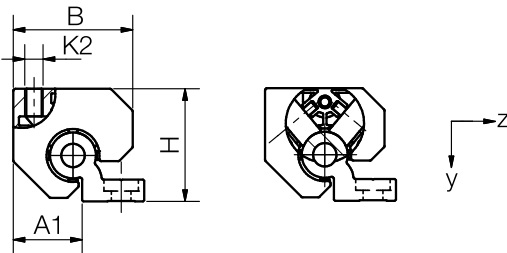
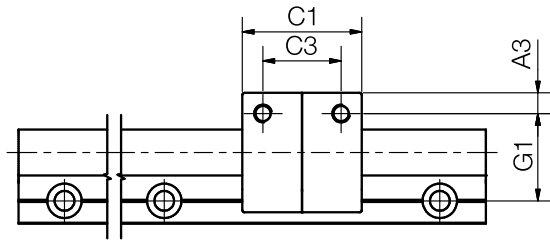

Technical data and dimensions [mm]

Part No.	Weight	A1	A3	B	C1	C3	G1	H	K2 for screw	Kz
	[g]									Max.
WJRM-21-10- HKA	115	16.5	6.5	31	35	22	27	28	M6	25
WJRM-21-16- HKA	250	25	9	44	48	30	32	41	M8	25
WJRM-21-20- HKA	320	30	9	52	52	34	38	49	M8	25

drylin® W profile guides | Product Range

Accessories: Liners and end caps for high profile rails

drylin® W plastic liners – long, open design



Liners Part No.	Pillow blocks	Size	Material	in the drylin® R-Chapter
JUMO-01-Ø	WJUM-01-Ø	10/16/20/25	iglide® J	► Page 1253
J200UMO-01-Ø™	WJ200UM-01-Ø	10/16/20/25 (standard)	iglide® J200	► Page 1259
E7UMO-01-Ø	WE7UM-01-Ø	10/16/20/25	iglide® E7	► Page 1261
XUMO-01-Ø	WXUM-01-Ø	10/16/20/25 (High temperature)	iglide® X	► Page 1264

™ Available also as floating bearing, Part No. J200UMO-01-Ø-LL

drylin® W liners – long design, square

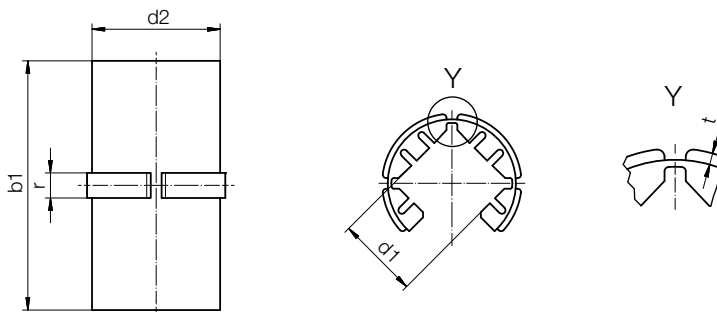

Dimensions [mm]

Part No.	d1 tolerance						
J200QM-01-06	5.0	+0.020 +0.080	8	19	3.0	0.5	
J200QM-01-10	7.5	+0.020 +0.080	12	28	3.0	0.8	
J200QM-01-16	11.5	+0.020 +0.080	18	35	3.0	0.8	
J200QM-01-20	15.0	+0.020 +0.080	23	44	3.5	0.8	

Available also as floating bearing J200QM-01-Ø-LLZ (z-direction), J200QM-01-Ø-LLY (y-direction)

drylin® W plastic liners – adjustable



Liners Part No.	Pillow blocks	Size	Material
JUME-01-10	WJUME-01-10	10 (adjustable)	iglide® J
J200UME-01-Ø	WJ200UME-01-Ø	16/20 (adjustable)	iglide® J200

drylin® W plastic liners

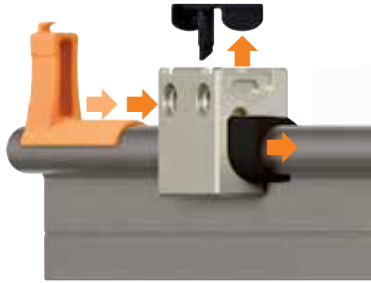

Liners Part No.	Pillow blocks	Size	Material
J200UMA-01-10	WJ200UMA-01-10-AL	10	iglide® J200
J200UMA-01-16	WJ200UMA-01-16-AL	16	iglide® J200
J200UMA-01-20	WJ200UMA-01-20-AL	20	iglide® J200

Replacement kit for WJ200UMA-01-10-AL pillow block



Consisting of

- 4 liners **J200UMA-01-10**
- 4 housing end caps **WRZ-0110071**
- Assembly tool **MAT0051290**



Part No.:

WEKA-01-10-J200



End caps for drylin® high profile rails WSX



- For drylin® W high profile rails WSX

► Page 1127

- 4 installation sizes
- Protection of the hollow chambers against the entry of foreign particle
- Easy to fit, easy sideways
- End caps for cutting edges



Part No.:

WSX-063001-EC
WSX-104001-EC
WSX-108001-EC
WSX-166001-EC

Slot nuts for mounting



- Variable positionable
- Ideal for drylin® limit and reference switches
- Suitable for T-slots of the drylin® WSX high-profile rails

► Page 1121, 1127

- Secure retention
- Can be retrofitted



Part No.:

WSX-06-30
WSX-06-60
WSX-10-40
WSX-10-80
WSX-16-60
WSX-16-60

Clamps for WSX high profile rails



- Secure mounting
- Variable positionable
- For drylin® SAW linear modules and ZLW toothed belt axes
- For drylin® WSX high-profile rails

► Page 1121, 1127



Part No.:

ZLW-0630
ZLW-0660
ZLW-1040
ZLW-1080
ZLW-1660

Rail connectors



- Join two lengths of drylin® W profile rails WS
- Machine rail with an inner bevel of 0.7 x 45° for a seamless joint or join as is
- Suitable for drylin® WS rails

► Page 1112



Part No.:

WSZ-011601
for use with
WS-16, WS-16-60
WSZ-012001
for use with
WS-20, WS-20-80
WSZ-012501
for use with
WS-25, WS-25-120



Notes

A large grid of graph paper for taking notes, consisting of 20 columns and 30 rows of small squares.



drylin® linear technology – drylin® N low-profile linear guides

Low profile and lightweight

Self-lubricating **dry-tech®** sliding elements

Anodized aluminum rail

High speed and acceleration possible

Quiet operation



drylin® N low-profile linear guides | Advantages

Lightweight, maintenance-free, corrosion-resistant and low wear

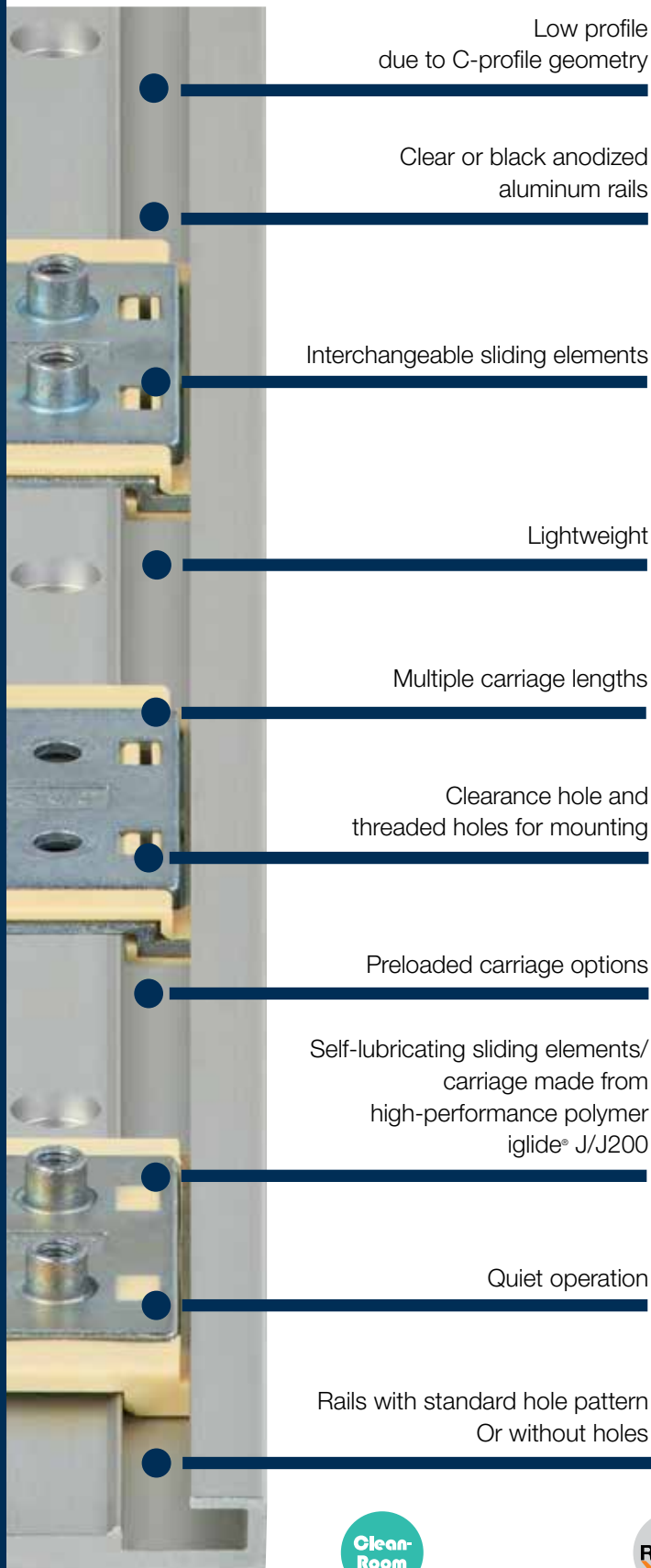

Low profile
due to C-profile geometry

Clear or black anodized
aluminum rails

Interchangeable sliding elements

Lightweight

Multiple carriage lengths

Clearance hole and
threaded holes for mounting

Preloaded carriage options

Self-lubricating sliding elements/
carriage made from
high-performance polymer
iglide® J/J200

Quiet operation

Rails with standard hole pattern
Or without holes

Self-lubricating low-profile linear guides – drylin® N

The low-profile range drylin® N offers extremely low profiles in several widths. Like all drylin® products, the carriages run without lubrication on an anodized aluminum profile. The selected materials and the unique design make drylin® N a cost-effective and flexible guide system.

- Low profile between 6 and 12mm
- Lightweight
- Many carriage options – also with preload
- Maintenance-free dry operation
- Corrosion-free
- Low wear with low coefficient of friction
- Silver or black-anodized rails

Typical application areas

- Agricultural machinery
- Automotive
- Medical technology
- Facade construction
- Packaging industry



Available from stock

Detailed information about delivery time online.



Price breaks online

No minimum order value. No minimum order quantity.



Max. +194°F

(+122°F for overmolded sliding elements)

Min. -40°F



17mm – 80mm



Service life calculation

► www.igus.com/drylin-expert



Cleanroom certified
IPA Fraunhofer



Free from toxins
2011/65/EU (RoHS)



ESD-compatible
(electrostatic discharge)

drylin® N low-profile linear guides | Product overview

Lightweight, maintenance-free, corrosion-resistant and low wear



Guide rails

- Four installation sizes: 17, 27, 40 and 80mm
 - Low profile, lightweight design
 - Clear anodized (silver) or black anodized surfaces
- From page 1168



Guide carriage – installation size 17mm (base width)

► Page 1169



Guide carriage – (installation size 27mm base width)

► Page 1170

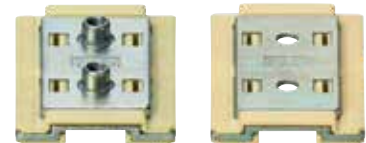

Guide carriage – installation size 40mm (base width)

► Page 1172-1173



Guide carriage – installation size 80mm (base width)

► Page 1174-1175



Telescopic system

- Continuous lengths up to 1,200mm (total extension)
 - Available with detents
 - With locking mechanism if required
- Page 1180



Preload prism slides

- Easy positioning of carriage
 - Four preload classes
 - Guaranteed drive force and holding force
 - Extremely lightweight low-profile
- From page 1176



Based on drylin® N

drylin® SLN miniature linear actuator
► from page 1619

drylin® N low-profile linear guides | Application examples



drylin® N is used for its very low-profile in this 3D printer

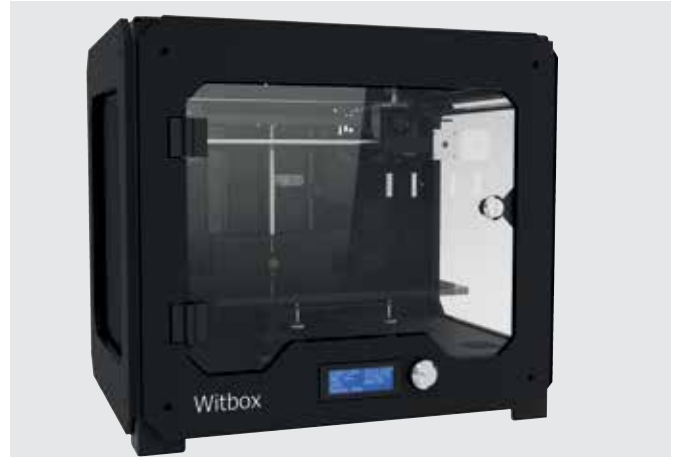

drylin® N low-profile linear guides and drylin® SD lead screw drives perform the height adjustments on this 3D printer. drylin® N with black anodize blends into the machine for aesthetics.



In the redesigning of the table guidance for this automated teller, the focus was on a ready-to-install, cost-effective, durable and self-lubricating bearing and system.



The quiet, self-lubricating, low-profile design of drylin® N made it the ideal solution and enabled it to fulfill all relevant safety requirements.



The pick-and-place unit is moved along the X-Y axis using the space-saving and cost-saving drylin® N low-profile linear guide. The drylin® T guide system is used for vertical guidance.



This sampling device uses drylin® linear plain bearings to remove the products precisely and smoothly.

drylin® N low-profile linear guides | online tools

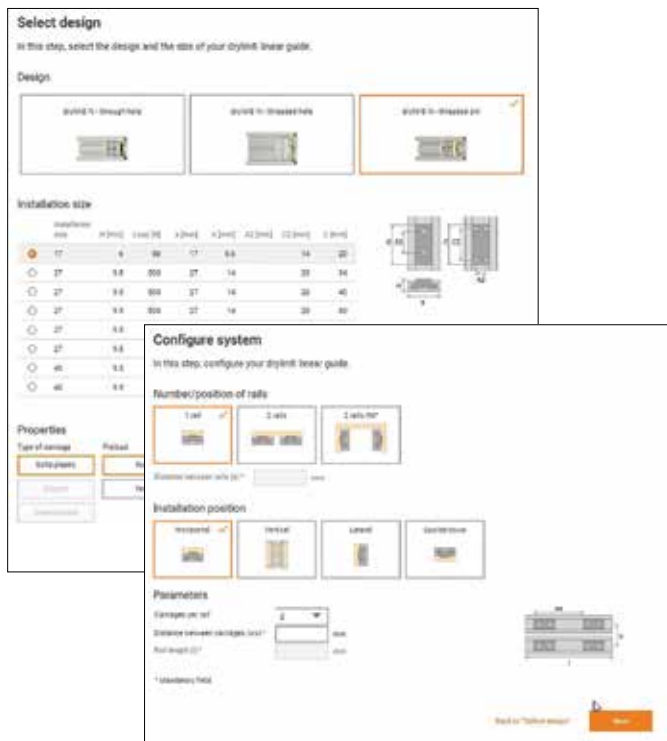

Expert for linear guides: System selection & service life calculation with CAD

Configure and calculate the service life of linear bearings – constantly expanded by new sizes and products

Easily calculate the service life of your required linear guide and configure with a few clicks. Select a drylin® system and add the relevant environmental parameters. Select the bearing size, carriage, number and position. Then enter the distance between the rails and the mounting. Define more relevant parameter of the guidance and select a rail length. The results are displayed.



► www.igus.com/drylin-expert



Download the online tool app now

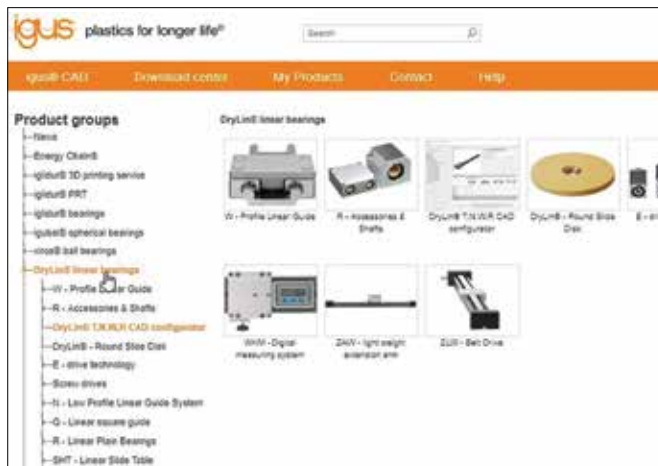

drylin® CAD configurator: Generate complete 3D models for drylin® linear technology according to your specifications

The igus® CAD online configurator gives you the ability to design and save your linear guide as a system, individual components directly as a 3D model in all commonly used formats, or to have these sent by e-mail – free of charge and without registration.



► www.igus.com/drylin-CAD

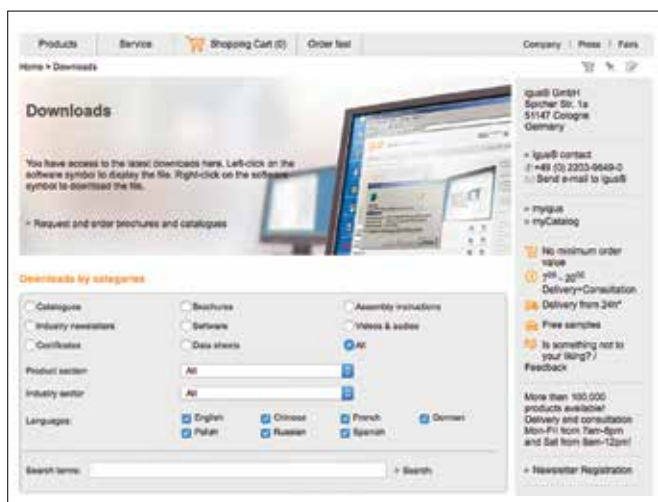

More information about the products can be found in the igus® download area

- Assembly instructions
- Assembly videos
- System design
- Catalogs



► www.igus.com/downloads

drylin® N low-profile linear guides | Design rules

Floating bearings version



- LLZ Floating bearing in z-direction
- LLY Floating bearing in y-direction
- LLZ Floating bearing in yz-direction

Floating bearing	NW-17	NW-27	NW-40	NW-80
LLY	0.6	0.45	0.4	0.6
LLZ	0.5	0.8	0.8	0.8
LLYZ	Y: 0.6 Z: 0.5	Y: 0.3 Y: 0.4	Y: 0.4 Y: 0.8	Y: 0.6 Y: 0.8

 **Technical details on floating bearings** ► Page 1097
The 2:1 Rule ► Page 1097

Technical options for drylin® low-profile linear guides

Clip-on sliding elements

Depending on the installation size, up to three self-lubricating sliding elements made from the high-performance polymer iglide® J are clipped on around the zinc die-casting carriage body. These can be changed any time simply and fast, the zinc die-casting carriage can be reused. A set of appropriate sliding elements is available for every clip-on carriage (Part No. NEK... ► Page 1184

Overmolded sliding elements

With this carriage type, the zinc die-cast body is overmolded with high-performance iglide® J or J200 during the production process. This makes it quicker to install the carriages in the profile. It is not possible to retrofit sliding elements; the carriages must be entirely replaced at the end of their service life. The continuous operating temperature for overmolded sliding elements is +122°F (+50°C).

Preload function

The use of sliding elements with an integrated spring preload function prevents the carriages in the rail profile from rattling. Adjustment occurs silently using the preload principle, making the guide suitable for use in noise-sensitive environments such as the automotive, medical or furniture sectors. Preload increases the displacement force by max. 10N.

Anodized surfaces

All drylin® N guide rails are anodized and are distinguished by good wear properties and corrosion resistance. All rail sizes are available as clear-anodized version (silver) as well as anti-reflect version with black-anodized surface. These are technical surfaces and not decorative. Slight crack formations and color variations cannot be prevented during production, but they do not affect the resistance, the corrosion behavior or the sliding properties. Cutting surfaces and machined surfaces are uncoated.

Tightening torque for drylin® connections between metal parts

Metric thread (Da)	Tightening torque [Nm]	Recommended tightening torque [Nm]
M3	0.5 – 1.1	0.7
M4	1.0 – 2.8	1.5
M5	2.0 – 5.5	3.0
M6	4.0 – 10.0	6.0
M8	8.0 – 23.0	15.0
M10	22.0 – 46.0	30.0

Please be aware of the minimal screw-in depth for aluminum and zinc die-casting parts: 1.5 x Da

drylin® N low-profile linear guides | Technical Data

System selection				
System	N17	N27	N40	N80
Rail width	17mm	27mm	40mm	80mm
Installation height	6mm	9.5mm	9.5mm	12mm
General properties				
Rail weight	150g/m	290g/m	450g/m	1,140g/m
Carriage weight	1.7g	9–12.5g	30g	100g
Max. rail length	2,000mm	3,000mm	3,000mm	4,000mm
Load capacity, static				
F _y	50N	500N	700N	1,000N
F _z	50N	500N	700N	1,000N
M _x	0.31Nm	5Nm	10Nm	32.4Nm
M _y , M _z	0.18Nm	2.5Nm	6Nm	15Nm
Carriage options				
Floating bearing in y-direction	●	●	●	●
Floating bearing in z-direction	●	●	●	●
Floating bearing in yz-direction	●	●	●	●
Preload (1N)	●	●	●	–
Overmolded version	–	●	●	●
Carriage with through hole	–	●	●	–
Carriage with threaded pin	●	●	●	–
Carriage with threaded hole	–	–	–	●

Table 01: System selection ● available – not available

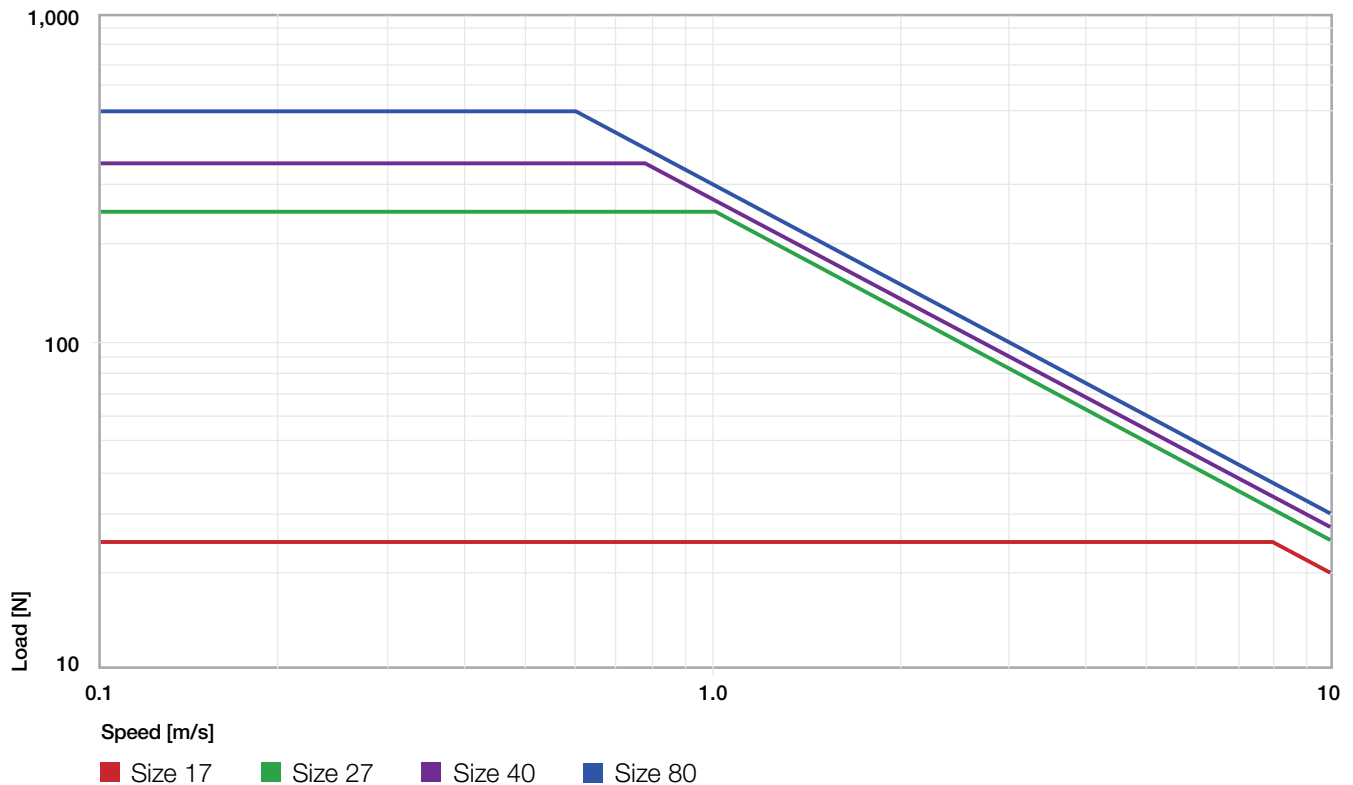

Diagram 01: F v diagram, maximum permissible dynamic load

drylin® N low-profile linear guides | Product Range

Guide rails and carriages – installation size 17



Order key

Type	Installation size	Options
NW - 22 - 17 - 30 - LLY		
drylin® N		
Guide carriages		
Type of carriage		
Rail width		
Carriage length		
Floating bearing in y-direction		

Type of carriage:
02: Carriage with threaded pin
22: Double carriage with threaded pin

Options:
P: Preload

Floating bearing:
LLY: y-direction
(not possible with the "P" version)
LLZ: z-direction
LLYZ: yz-direction

Guide rail – dimensions [mm]

Part No.	L	a	C4	C5	C6	h	h1	K1 ⁷²⁾	ly	lz	Weight
	Max.			Min.	Max.				[mm ²]	[mm ²]	[g/m]
NS-01-17- <input type="text"/> ⁷²⁾	2,000	17	60	20	49.5	5.5	0.9	Ø3.5	1,700	120	150
NS-01-17-S- <input type="text"/> ⁷²⁾ (no mounting holes)	2,000	17	–	–	–	5.5	0.9	–	1,700	120	150
NS-01-17-AR- <input type="text"/> ⁷²⁾ (black anodized)	2,000	17	60	20	49.5	5.5	0.9	Ø3.5	1,700	120	150

Guide carriage – dimensions [mm]

Part No.	H	A	C	C2	K3 ⁷⁴⁾	Sp	Dp ¹⁵⁹⁾	Weight [g]
	±0.35							
NW-02-17	6.0	9.6	20	14	M3	2.5	5.0	1.7
NW-02-17-P	6.0	9.6	20	14	M3	2.5	5.0	1.7
NW-22-17-30	6.0	9.6	30	18	M3	2.5	5.0	2.4
NW-22-17-40	6.0	9.6	40	28	M3	2.5	5.0	2.6

⁷²⁾ Please give the required length in mm, symmetrical standard hole pattern C5=C6

⁷³⁾ For cap screw with low head (e.g. DIN 7984, DIN 6912, DIN 84, EN ISO 1707)

⁷⁴⁾ Metal thread

¹⁵⁹⁾ Hole min. Ø



NS-01-17-1500: Guide rail, installation size 17, 1,500mm length

drylin® N low-profile linear guides | Product Range

The linear guide for the smallest installation space

drylin® N
low-profile
linear
guides



NW-02-17



NW-02-17-P



NW-22-17-30



NW-22-17-40

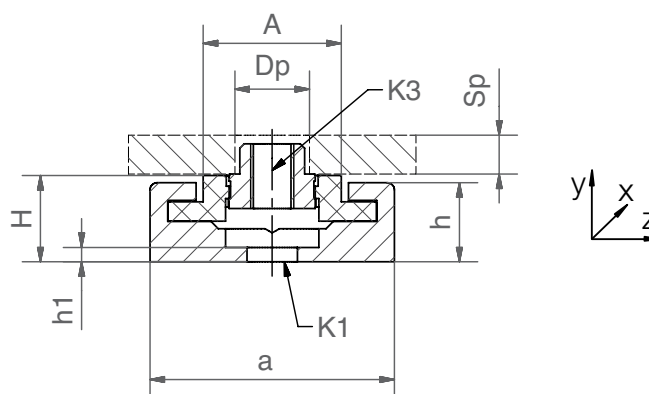
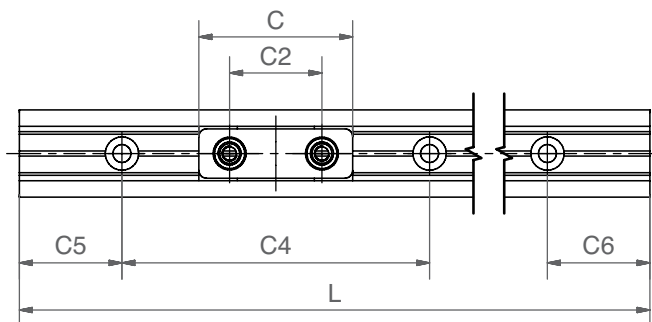

Selection aid – guide carriage

Part No.	Standard length	Longer length	Through hole	Threaded pin	Threaded hole	Preload	Solid plastic	Clipped on	Over-molded	High temp.
NW-02-17	●			●			●			
NW-02-17-P	●			●		●	●			
NW-22-17-30		●		●			●			
NW-22-17-40		●		●			●			

drylin® N low-profile linear guides | Product Range

Guide rails and carriages – installation size 27



Order key

Type	Size	Options
NW - 01 - 27 - HT - LLY		
drylin® Guide carriages	Type of carriage	Rail width
	High temperature	Floating bearing in y-direction

Type of carriage:
See selection aid

Options:
P: Preload
HT: High temperature
Floating bearing:
LLY: y-direction
LLZ: z-direction
LLYZ: yz-direction

Guide rail – dimensions [mm]

Part No.	L	a	C4	C5 C6	h	h1	K1 ⁷⁵⁾	ly	lz	Weight [g/m]
	Max.			Min. Max.				[mm ²]	[mm ²]	
NS-01-27- <input type="text"/> ⁷⁵⁾	3,000	27	60	20 49.5	9	1.1	Ø4.5	6,524	588	290
NS-01-27-S- <input type="text"/> ⁷⁵⁾ (no mounting holes)	3,000	27	–	– –	9	1.1	–	6,524	588	290
NS-01-27-AR- <input type="text"/> ⁷⁵⁾ (black anodized)	3,000	27	60	20 49.5	9	1.1	Ø4.5	6,524	588	290

Guide carriage – dimensions [mm]

Part No.	H	A	C	C1	C2	H2	K ⁷⁵⁾	K3 ⁷⁶⁾	M ⁷⁵⁾	Sp	Dp ¹⁵⁸⁾	Weight [g]
	±0.35								[Nm]			
NW-01-27	9.5	14.0	40	30	20	1.2	Ø4.5	–	–	–	–	10.8
NW-11-27	9.5	14.0	34	30	20	1.2	Ø4.5	–	–	–	–	10.8
NW-01-27-P	9.5	14.0	40	30	20	1.2	Ø4.5	–	–	–	–	10.8
NW-01-27-HT	9.5	14.0	40	30	20	1.2	Ø4.5	–	–	–	–	11.0
NW-02-27	9.5	14.0	40	30	20	–	–	M4	1.2	5.0	6.5	12.5
NW-12-27	9.5	14.0	34	30	20	–	–	M4	1.2	5.0	6.5	12.5
NW-02-27-P	9.5	14.0	40	30	20	–	–	M4	1.2	5.0	6.5	12.5
NW-02-27-HT	9.5	14.0	40	30	20	–	–	M4	–	5.0	6.5	13.0
NW-21-27-60-P	9.5	14.0	60	60	20	0.7	Ø4.5	–	–	–	–	9.0
NW-22-27-60-P	9.5	14.0	60	60	20	–	–	M4	1.2	5.0	6.5	12.0
NW-31-27-60-P	9.5	14.0	60	60	40	0.7	–	M4	–	–	–	9
NW-32-27-60-P	9.5	14.0	60	60	40	–	–	M4	1.2	5	6.5	12
NW-11-27-80	9.5	14.0	80	76	60	1.2	Ø4.5	–	–	–	–	25.0
NW-12-27-80	9.5	14.0	80	76	60	–	–	M4	1.2	5.0	6.5	25.0

⁷⁵⁾ Please give the required length in mm, symmetrical standard hole pattern C5=C6

⁷⁶⁾ For cap screw with low head (e.g. DIN 7984, DIN 6912, DIN 84, EN ISO 1707)

⁷⁶⁾ Metal thread ⁷⁵⁾ Max. screw tightening torque ¹⁵⁸⁾ Hole min. Ø



NS-01-27-1500: Guide rail, installation size 27, 1,500mm length

NW-02-27-P-LLY: Guide carriage with threaded pin, installation size 27, preload, floating bearing in y-direction

drylin® N low-profile linear guides | Product Range

The installation size with the largest variety of carriages

drylin® N
low-profile
linear
guides



NW-01-27



NW-01-27-P



NW-01-27-HT



NW-02-27



NW-02-27-P



NW-02-27-HT



NW-21-27-60-P



NW-22-27-60-P



NW-11-27



NW-12-27



NW-32-27-60-P



NW-11-27-80



NW-12-27-80

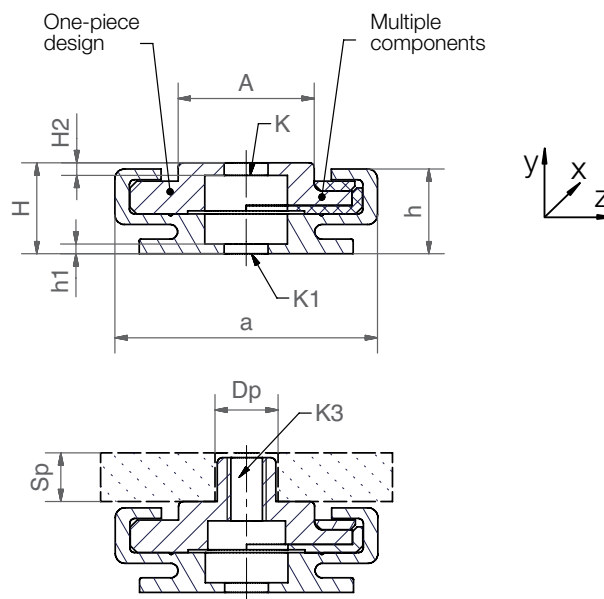
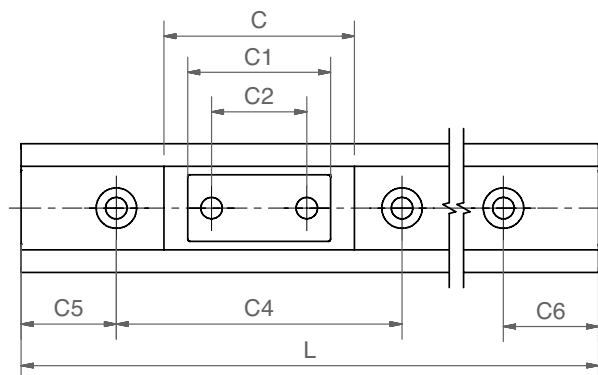

Selection aid – guide carriage

Part No.	Standard length	Longer length	Through hole	Threaded pin	Threaded hole	Preload	Solid plastic	Clipped on	Overmolded	High temp.
NW-01-27	•		•					•		
NW-11-27	•		•						•	
NW-01-27-P	•		•			•		•		
NW-01-27-HT	•		•					•		•
NW-02-27	•			•				•		
NW-12-27	•			•					•	
NW-02-27-P	•			•		•		•		
NW-02-27-HT	•			•				•		•
NW-21-27-60-P	•		•			•	•			
NW-22-27-60-P	•			•		•	•			
NW-31-27-60-P	•		•			•	•			
NW-32-27-60-P	•			•		•	•			
NW-11-27-80		•	•						•	
NW-12-27-80		•		•					•	

drylin® N low-profile linear guides | Product Range

Guide rails and carriages – installation size 40

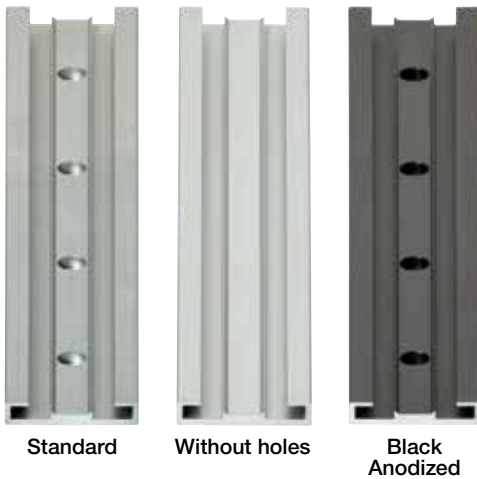

Type	Size	Options
NW - 01 - 40 - P - LLY		
drylin® N	Guide carriages	Type of carriage: See selection aid
Type of carriage	Rail width	Options: P: Preload
Preload	Floating bearing in y-direction	Floating bearing: LLY: y-direction LLZ: z-direction LLYZ: yz-direction

Guide rail – dimensions [mm]

Part No.	L	a	C4	C5 C6	h	h1	K1 ^{7a)}	ly	lz	Weight
	Max.			Min. Max.				[mm]	[mm]	[g/m]
NS-01-40- <input type="text"/> ^{7a)}	3,000	40	60	20 49.5	8.7	1.3	Ø4.5	26,400	970	450
NS-01-40-S- <input type="text"/> ^{7a)} (no mounting holes)	3,000	40	–	–	8.7	1.3	–	26,400	970	450
NS-01-40-AR- <input type="text"/> ^{7a)} (black anodized)	3,000	40	60	20 49.5	8.7	1.3	Ø4.5	26,400	970	450

Guide carriage – dimensions [mm]

Part No.	H	A	C	C1	C2	H2	K ^{7a)}	K3 ^{7a)}	Sp	Dp ^{15a)}	Weight
	±0.35										[g]
NW-01-40	9.5	23.0	50	40	20	1.3	Ø4.5	–	–	–	30.0
NW-01-40-P	9.5	23.0	50	40	20	1.3	Ø4.5	–	–	–	30.0
NW-11-40	9.5	23.0	52	40	20	1.3	Ø4.5	–	–	–	30.0
NW-02-40	9.5	23.0	50	40	20	–	–	M4	5.0	6.5	30.0
NW-02-40-P	9.5	23.0	50	40	20	–	–	M4	5.0	6.5	30.0
NW-12-40	9.5	23.0	52	40	20	–	–	M4	5.0	6.5	30.0

^{7a)} Please give the required length in mm, symmetrical standard hole pattern C5=C6

^{7a)} For cap screw with low head (e.g. DIN 7984, DIN 6912, DIN 84, EN ISO 1707)

^{7a)} Metal thread

^{15a)} Hole min. Ø



NS-01-40-1500: Guide rail, installation size 40, 1,500mm length

NW-02-40-P-LLY: Guide carriage with threaded pin, installation size 40, preload, floating bearing in y-direction

drylin® N low-profile linear guides | Product Range

Suitable for aluminum construction profiles

drylin® N
low-profile
linear
guides

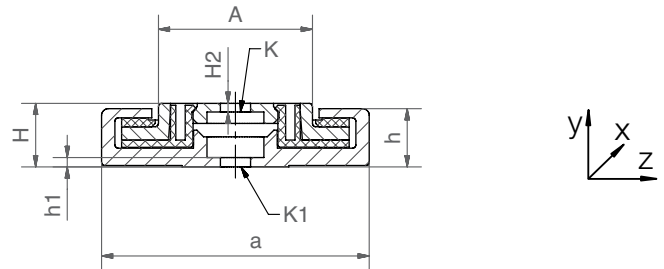
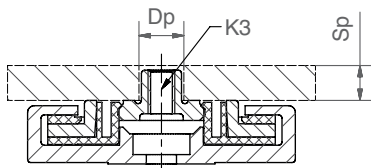
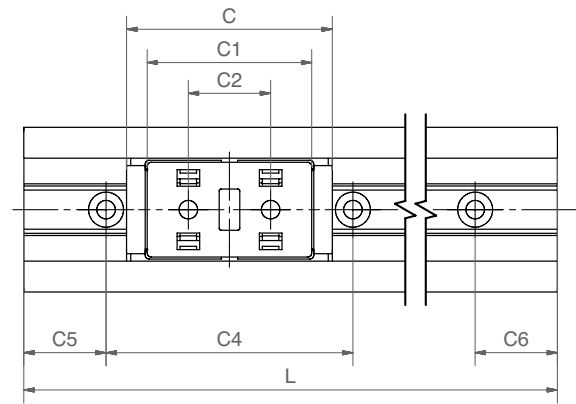
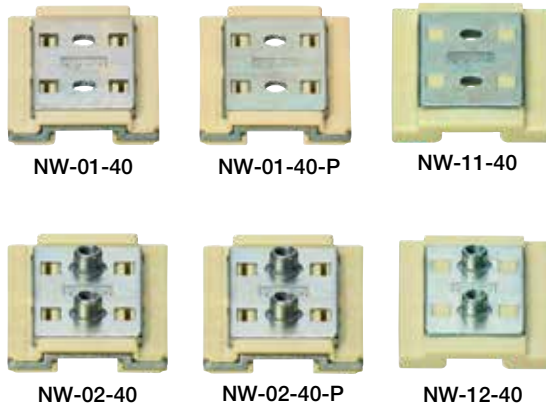

Selection aid – guide carriage

Part No.	Standard length	Longer length	Through hole	Threaded pin	Threaded hole	Preload	Solid plastic	Clipped on	Overmolded	High temp.
NW-01-40	●		●					●		
NW-01-40-P	●		●			●		●		
NW-11-40	●		●						●	
NW-02-40	●			●				●		
NW-02-40-P	●			●		●		●		
NW-12-40	●			●					●	

drylin® N low-profile linear guides | Product Range

Guide rails and carriages – installation size 80



Order key

Type	Size	Options
NW - 02 - 80 - LLY		
drylin® N Guide carriages	Type of carriage	Floating bearing in y-direction
	Rail width	Type of carriage: See selection aid Options: Floating bearing: LLY: y-direction LLZ: z-direction LLYZ: yz-direction

Guide rail (standard/without holes/AR anti-reflect) – Dimensions [mm]

Part No.	L	a	C4	A3	C5	C6	h	h1	K1 ^{7a)}	ly	lz	Weight
	Max.				Min.	Max.				[mm ²]	[mm ²]	[g/m]
NS-01-80- <input type="checkbox"/> ^{7a)}	4,000	80	150	40	25	99.5	11	1.5	Ø4.5	27,120	2,900	1,140
NS-01-80-S- <input type="checkbox"/> ^{7a)} (no mounting holes)	4,000	80	–	–	–	–	11	1.5	–	27,120	2,900	1,140
NS-01-80-AR- <input type="checkbox"/> ^{7a)} (black anodized)	4,000	80	150	40	25	99.5	11	1.5	Ø4.5	27,120	2,900	1,140

Guide carriage – dimensions [mm]

Part No.	H	A	C	C1	C2	A2	K4 ^{7a)}	Weight
	±0.35							[g]
NW-02-80	12.0	57.0	80	68	56	45	M4	100.0
NW-12-80	12.0	57.0	83	68	56	45	M4	146.3

^{7a)} Please give the required length in mm, symmetrical standard hole pattern C5=C6

^{7b)} For cap screw with low head (e.g. DIN 7984, DIN 6912, DIN 84, EN ISO 1707)

^{7c)} Metal thread



NS-01-80-1500: Guide rail, size 80, 1,500mm length

NW-02-80-LLY: Guide carriage, clip-on, installation size 80, floating bearing in y-direction,

drylin® N low-profile linear guides | Product Range

For high speeds at low loads

drylin® N
low-profile
linear
guides



NW-02-80



NW-12-80

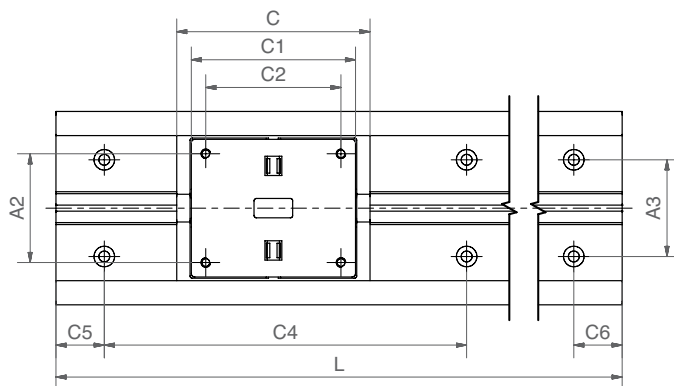
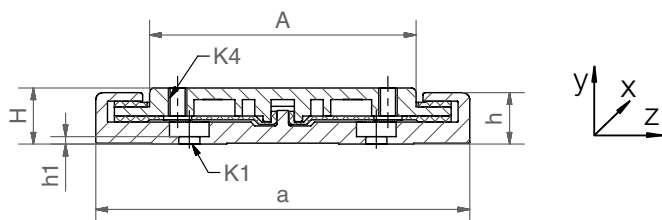

Selection aid – guide carriage

Part No.	Standard length	Longer length	Through hole	Threaded pin	Threaded hole	Preload	Solid plastic	Clipped on	Overmolded	High temp.
NW-02-80	●				●			●		
NW-12-80	●				●				●	

drylin® N low-profile linear guides | Product Range

Prism guides with preload



Standard

Without holes



Order key

Type Installation size Options

NSV - 01 - 27 - S

Guide rails for
preload prism slide

Type

Installation size

Without holes

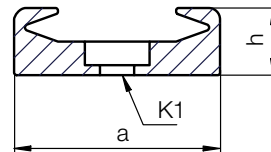
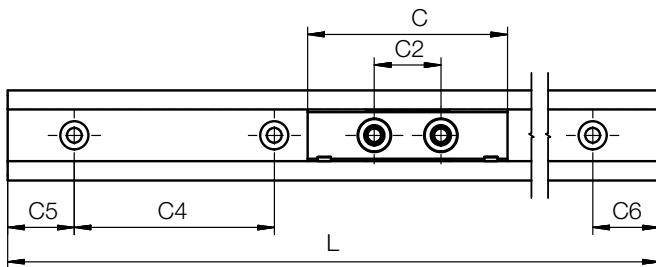

Guide rail – dimensions [mm]

Part No.	C	C2	h	L	C4	C5	C6	a	K1	ly	lz	Weight
	Carriage length	Carriage hole distance on center	Rail height	Length Max.		Min.	Max.	Rail width		[mm']	[mm']	[g/m]
NSV-01-27	35	20	8.8	3,000	60	20	49.5	27	Ø4.5	11,250	766	409
NSV-01-27-S ^{7a}	35	20	8.8	3,000	-	-	-	27	-	11,250	766	409

^{7a} For rails without mounting holes, please use part number suffix "S"

^{7a} Please give the required length in mm, symmetrical standard hole pattern C5=C6

drylin® N low-profile linear guides | Product Range

Preload prism slide, standard design

drylin® N
low-profile
linear
guides

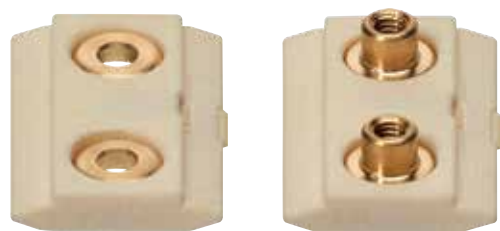

Type 21

Type 22

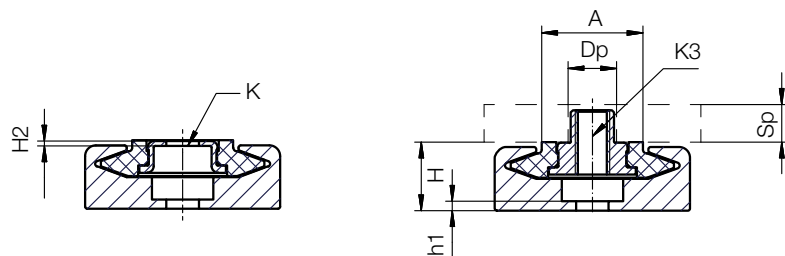

Order key

Type Installation size Options

NWV - 21 - 27 - 35 - P05

Preload prism slide

Type of carriage

Rail width

Carriage length

Preload

Guide carriage – dimensions [mm]

Part No.	Preload [N]	A	H ±0.35	h1	H2	K	K3	M ⁷⁵⁾ [Nm]	Sp Min.	Dp ¹⁵⁹⁾	Weight [g]
NWV-21-27-35-P05	5	14	9.5	1.1	0.7	Ø4.5	–	–	–	–	6
NWV-21-27-35-P11	11	14	9.5	1.1	0.7	Ø4.5	–	–	–	–	6
NWV-21-27-35-P23	23	14	9.5	1.1	0.7	Ø4.5	–	–	–	–	6
NWV-21-27-35-P38	38	14	9.5	1.1	0.7	Ø4.5	–	–	–	–	6
NWV-22-27-35-P05	5	14	9.5	1.1	–	–	M4	1.2	5	5	11
NWV-22-27-35-P11	11	14	9.5	1.1	–	–	M4	1.2	5	5	11
NWV-22-27-35-P23	23	14	9.5	1.1	–	–	M4	1.2	5	5	11
NWV-22-27-35-P38	38	14	9.5	1.1	–	–	M4	1.2	5	5	11

⁷⁵⁾ Max. screw tightening torque

¹⁵⁹⁾ Hole min. Ø

Part No.	Average displacement force	Guaranteed holding force
	[N]	[N]
NWV-21/22-27-35 P05	1.0	0.5
NWV-21/22-27-35 P11	2.2	1.1
NWV-21/22-27-35 P23	4.6	2.3
NWV-21/22-27-35 P38	7.6	3.8



Note:

The average displacement force values apply to unloaded carriages at centric drive. The real displacement forces depend to a large extent on the displacement speed. At creep movement (few mm/min.), the values are slightly over the guaranteed holding force. At higher displacement forces, the values can considerably exceed the average displacement force. The values do not apply for applications in which dirt and moisture ingress into the system.

drylin® N low-profile linear guides | Product Range

Prism rails



Standard

Without holes



Order key

Type Installation size Options

NSV - 01 - 27 - S

Guide rails for
preload prism slide

Type

Installation size

Without holes

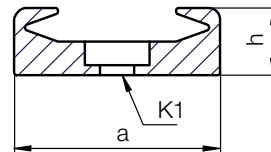
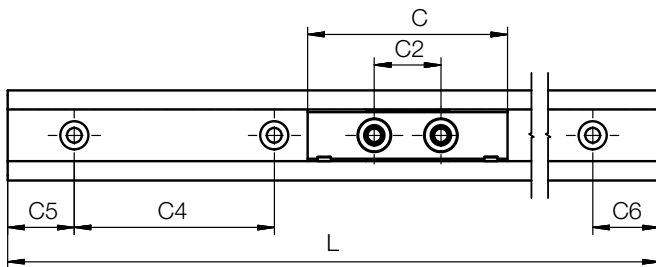

Guide rail – dimensions [mm]

Part No.	C	C2	h	L	C4	C5	C6	a	K1	ly	lz	Weight
	Carriage length	Carriage hole distance on center	Rail height	Length Max.		Min.	Max.	Rail width		[mm']	[mm']	[g/m]
NSV-01-27	60	20	8.8	3,000	60	20	49.5	27	Ø4.5	11,250	766	409
NSV-01-27-S ^{7a}	60	20	8.8	3,000	-	-	-	27	-	11,250	766	409

^{7a} For rails without mounting holes, please use part number suffix "S"

^{7a} Please give the required length in mm, symmetrical standard hole pattern C5=C6

drylin® N low-profile linear guides | Technical Data

Preload prism slide, long design



Type 21

Type 22

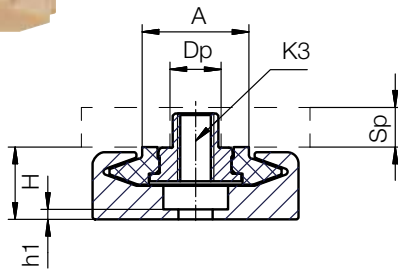
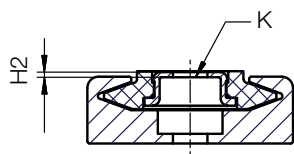

Order key

Type Installation size Options

NWV - 21 - 27 - 60 - P10

Preload prism slide	Type of carriage	Rail width	Carriage length	Preload
---------------------	------------------	------------	-----------------	---------

Guide carriage – dimensions [mm]

Part No.	Preload [N]	A	H ±0.35	h1	H2	K	K3	M ⁷⁹⁾ [Nm]	Sp Min.	Dp ¹⁹⁹⁾	Weight [g]
NWV-21-27-60-P10	1.0	14	9.5	1.1	0.7	Ø4.5	–	–	–	–	10
NWV-21-27-60-P22	2.2	14	9.5	1.1	0.7	Ø4.5	–	–	–	–	10
NWV-21-27-60-P46	4.6	14	9.5	1.1	0.7	Ø4.5	–	–	–	–	10
NWV-21-27-60-P76	7.6	14	9.5	1.1	0.7	Ø4.5	–	–	–	–	10
NWV-22-27-60-P10	1.0	14	9.5	1.1	–	–	M4	1.2	5	6.5	13
NWV-22-27-60-P22	2.2	14	9.5	1.1	–	–	M4	1.2	5	6.5	13
NWV-22-27-60-P46	4.6	14	9.5	1.1	–	–	M4	1.2	5	6.5	13
NWV-22-27-60-P76	7.6	14	9.5	1.1	–	–	M4	1.2	5	6.5	13

⁷⁹⁾ Max. screw tightening torque

¹⁹⁹⁾ Hole min. Ø

Part No.	Average displacement force	Guaranteed holding force
	[N]	[N]
NWV-21/22-27-60-P10	2.0	1.3
NWV-21/22-27-60-P22	4.4	4.2
NWV-21/22-27-60-P46	9.2	6.2
NWV-21/22-27-60-P76	15.2	11.7



Note:

The average displacement force values apply to unloaded carriages at centric drive. The real displacement forces depend to a large extent on the displacement speed. At creep movement (few mm/min.), the values are slightly over the guaranteed holding force. At higher displacement forces, the values can considerably exceed the average displacement force. The values do not apply for applications in which dirt and moisture ingress into the system.

drylin® N low-profile linear guides | Product Range

Telescopic rails

- Robust plastic/aluminum version
- Lightweight
- Cost-effective
- Corrosion-free
- Continuous lengths up to 1,200mm (total extension)

NT-35-"L" – Total extension

C5: 20–49.5mm

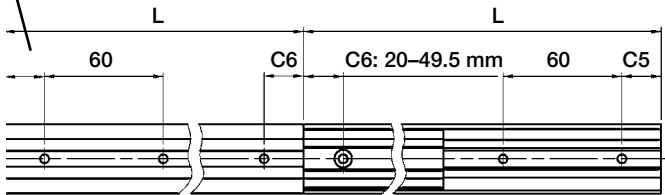

NT-35-"L"-"L+20" – Over extension

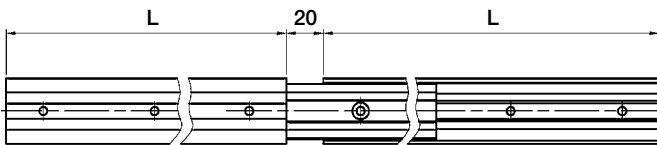

NT-35-"L"-"B" – Partial extension

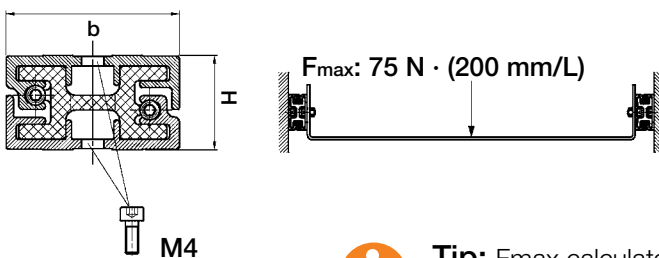
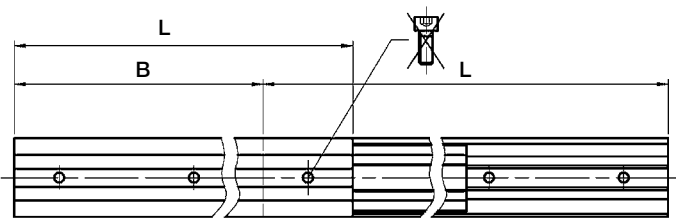

Tip: F_{max} calculated using this formula allows an easy manual use. Higher loads can be taken up by the system, but need a higher drive force.

Dimensions [mm]

Part No.	b	H	L min.	L max.
NT-35-... mm	35	19	100	600



Order key

Type	Size
N T - 35 - 300	
drylin® N	Telescopic system
Rail width	Length [mm]



Order key over-extension

Type	Size	Option
N T - 35 - 300 - 320		
drylin® N	Telescopic system	Rail width
Rail width	Length [mm]	Over-extension [mm]



Order key partial extension

Type	Size	Option
N T - 35 - 300 - 200		
drylin® N	Telescopic system	Rail width
Rail width	Length [mm]	Partial extension [mm]

Option:
Partial extension
(e.g.: telescoped
length 300mm,
extended length
500mm)

drylin® N low-profile linear guides | Product Range

Telescopic rails with locking mechanism

drylin® N
low-profile
linear
guides



Order key

Type	Size	Option
drylin® N	NT - LM - 35 - 300	
Telescopic system		
Locking mechanism		
Rail width		
Length [mm]		



C5 = 20-49.5mm

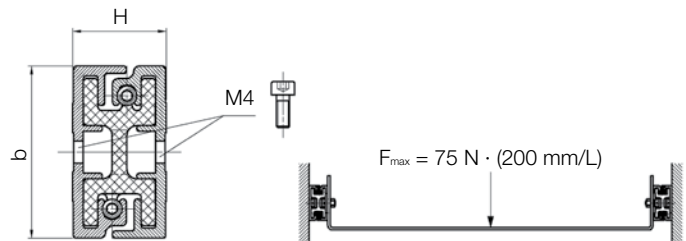
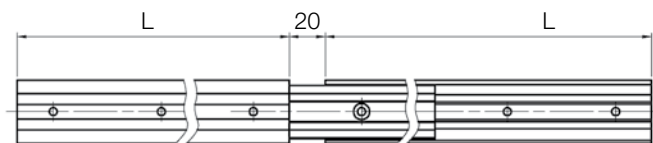
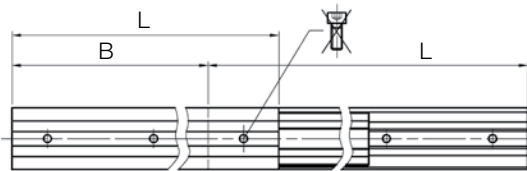
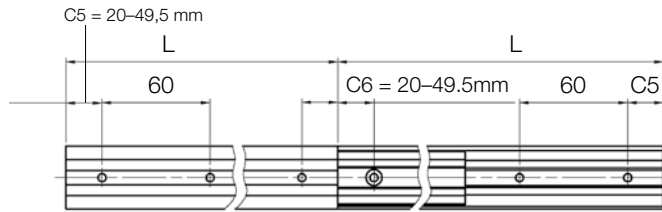

drylin® NT LM in adjustment of Perspex guard



drylin® NT LM in guard door adjustment in a machine tool

drylin® detent in end and center position at full extension – dimensions [mm]

Part No.	b	H	Lmin	Lmax.
NT-LM-35-...mm	35	19	140	600

Individual position detent upon request; The length divided by the locking distance must be an even number.
e.g. Length 250mm, latching in 62.5mm step: $250/62.5 = 4$



Order example:

NT-LM-35-300: drylin® N telescopic rail with locking mechanism, 35mm width, retracted length 300mm



Order key

Type	Size	Version
NW - 12 - 27 - 80 - HKA		
drylin® N Guide carriages	Type of carriage	Rail width
		Carriage length
		Manual clamp

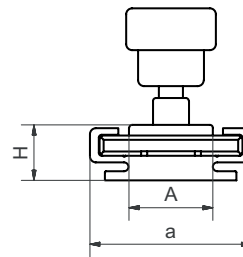
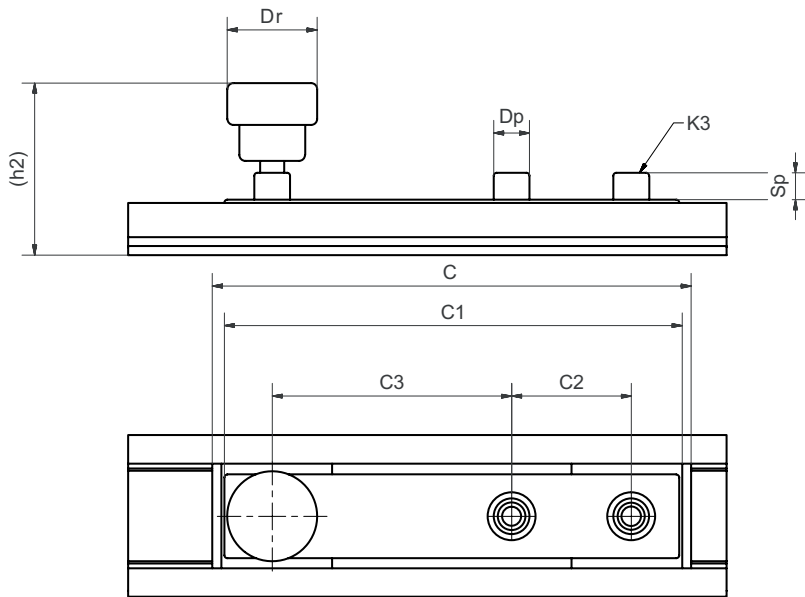

Dimensions [mm]

Part No.	H	(h2)	A	a	C	C1	C2	C3	K3	M	Sp	Dp	Dr	Weight
										[Nm]				[g]
NW-12-27-80-HKA	9.5	32	14	27	80	76	20	40	M4	1.2	5	6.5	15	32

M: Permissible torque of the complete system



Order example:

NW-12-27-80-HKA: Manual clamp for NW-12-27-80 carriage

drylin® N low-profile linear guides | Product Range

Accessories: End caps

drylin® N
low-profile
linear
guides



Order key

Type Size

NSKB - 40

drylin® N -
End cap

Push-fit

Rail width

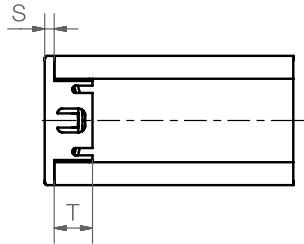

Dimensions [mm]

Part No.	S	T	For rail
NSKB-17	1.5	7	NS-01-17
NSKB-27	2.0	8	NS-01-27
NSK-40	1.5	8	NS-01-40
NSKB-80	2.0	17	NS-01-80



Order example:

NSK-40: End caps for guide rail size 40, bolted



Easily assembled and disassembled by hand using a screwdriver.
Part No.: NSKB



End caps for rail size 40, screwed
Part No.: NSK-40

drylin® N replacement plastic sliders (set)

Material iglide® J

Carriage type	Part No.
NW-01/02/27	NEK-01-27
NW-01/02-27P	NEK-01-27-P
NW-01/02-27-LLY	NEK-01-27-LLY
NW-01/02-27-LLZ	NEK-01-27-LLZ
NW-01/02-40	NEK-02-40
NW-01/02-40P	NEK-01-40-P
NW-01/02-40-LLY	NEK-02-40-LLY
NW-01/02-40-LLZ	NEK-02-40-LLZ
NW-02-80	NEK-02-80
NW-02-80-LLY	NEK-02-80-LLY
NW-02-80-LLZ	NEK-02-80-LLZ



drylin[®] linear technology – drylin[®] T rail guides

Robust linear guides

Adjustable bearing clearance

Wear-resistant and durable

Dimensionally identical to recirculating
ball-bearing guides

Self-lubricating and maintenance-free



drylin® T rail guides | Advantages

Resistant to dirt, low vibration, low noise, long service life



Profile rail with
hard-anodized surface

Clear, anodized aluminum
carriage body

Sliding elements made from
high-performance polymer
iglide® J and J200 serve as a
guide bearing and ensure
optimum running properties

End cap made of solid plastic
or stainless steel

Automatic clearance adjustment

Self-lubricating rail guides – drylin® T

drylin® T rail guides were originally developed for applications in both automation and materials handling. The goal was to create a durable linear guide for use in the most diverse, even extreme environments. Their dimensions are identical to most recirculating ball bearing guides.

- 100% self-lubricating
- Adjustable bearing clearance
- Automatic clearance adjustment
- High static load capacity
- Long service life
- Resistant to dirt
- Low vibration and quiet

Typical application areas

- Machine building
- Wood working industry
- Automation
- Handling



Available from stock

Detailed information about delivery time online.



Price breaks online

No minimum order value. No minimum order quantity.



Max. +194°F (+90°C)

Min. -40°F (-40°C)



7 carriage types

Rail length up to 4,000mm



Service life calculation

► www.igus.com/drylin-expert



Cleanroom certificated
IPA Fraunhofer



Free from toxins
2011/65/EU (RoHS)



ESD-compatible
(electrostatic discharge)

drylin® T rail guides | Product overview

Dimensionally identical to most recirculating ball-bearing guides



drylin® T rails

- Lightweight, aluminum extruded section
- Robust and corrosion-resistant hard-anodized surfaces
- Shaft length delivered with millimeter precision up to max. 4,000mm

► Page 1192



Standard / with manual clamp

- Manual clearance adjustment
- Long service life with iglide® J sliding elements
- Optional manual clamp

► From page 1193



Automatic

- Automatic clearance adjustment
- Easy assembly with preload key
- Long service life with iglide® J sliding elements

► Page 1194



High performance

- iglide® J200 for higher service life
- Fast assembly
- Adjustable bearing clearance

► From page 1195



Heavy duty

- Durable design, factory clearance adjustment
- Long service life with iglide® J-sliding elements
- Quick assembly

► Page 1197



Compact

- Narrow guide carriages for small spaces
- Captive plastic sliders
- Corrosion-free

► Page 1198

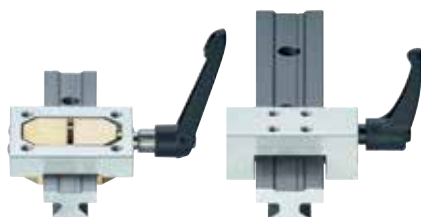

Clamps

- Compact or heavy duty design
- Available for installation sizes 15-30mm
- Holding force up to 500N

► Page 1199



Miniature guides / Adjustable miniature guides

- Small compact design
- Easy to fit
- Individual clearance adjustment on carriage

► Page 1200-1201



Based on drylin® T drylin® SLT linear module

► From page 1615

drylin® T rail guides | Application examples



Food processing application using drylin® T in a caustic wash-down environment



drylin® T replaced ball bearings on this grinding machine exposed to metal shavings



The drylin® T linear guides are used in these enveloping machines to guide an envelope suction opener that is mounted on one side.



Due to the welding spatter and dust, the use of the extremely dirt-resistant drylin® T linear guide finds the balance between high service life and low costs.



drylin® T rail guides with adjustable clearance change the height of this work table silently and precisely.



Time saving: Reduced tool changing time due to this measuring system. The gauge is guided on a drylin® T rail. This solution works also without problems in dusty environments.

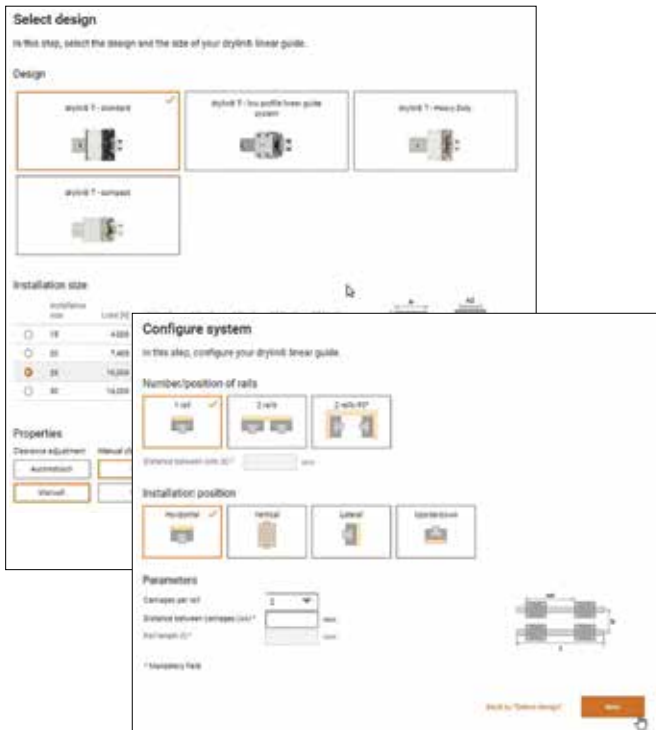

Expert for linear guides: System selection and service life calculation with CAD

Configure linear bearings and calculate their service life – constantly expanded by new sizes and products

Easily calculate the service life of your required linear guide and configure with a few clicks. Select a drylin® system and add the relevant environmental parameters. Select the bearing size, carriage, number and position. Then enter the distance between the rails and the mounting. Define the coordinates for the drive location and the center of gravity, or enter these via the keyboard. Define the weight, acceleration, and distance of the bearing and select a rail length. The results are displayed.



► www.igus.com/drylin-expert



drylin® CAD configurator: Generate complete 3D models for drylin® linear technology according to your specifications

The igus® CAD online configurator gives you the ability to design and save your linear guide as a system, individual components directly as a 3D model in all commonly used formats, or to have these sent by e-mail – free of charge and without registration.



► www.igus.com/drylin-CAD



More information about the products can be found in the igus® download area

- Assembly instructions
- Assembly videos
- System design
- Catalogs



► www.igus.com/downloads

drylin® T rail guides | Design rules

Design tip

The compensation of parallelism errors up to a maximum of 0.5mm between mounted rails is possible with a fixed/floating bearing. During installation, make sure that the floating bearing has approximately the same clearance on both sides.

In the adjacent designs you can see the version of the fixed/floating bearing system recommended by us.

The mounting surfaces of the rails and guide carriages should be very flat (e.g. machined surface) to prevent twisting in the system. Small discrepancies in the mounting surfaces can be compensated up to a certain amount (0.5mm) by a greater clearance adjustment. The clearance adjustment is possible only in unloaded state. If you have any questions on design and/or assembly, please make use of our technical support.



Technical details on floating bearings

► Page 1097

The 2:1 Rule ► Page 1097

Installation drylin® T linear guide system

Make sure to assemble the side of the carriage saying "Reset Clearance" onto the rail first (see picture).



TW series, adjustable clearance

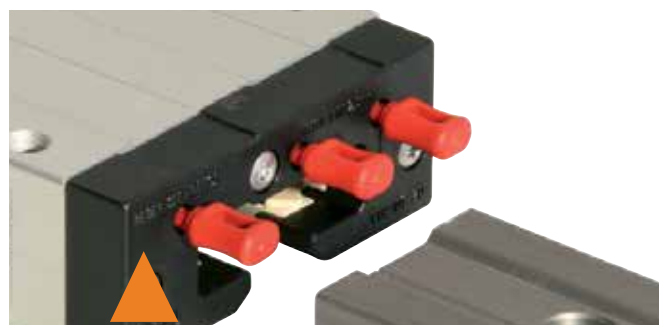

TWA series, automatic

Tightening torque for drylin® connections between metal parts

Metric thread (Da)	Torque	Recommended tightening torque
	[Nm]	[Nm]
M3	0.5 – 1.1	0.7
M4	1.0 – 2.8	1.5
M5	2.0 – 5.5	3.0
M6	4.0 – 10.0	6.0
M8	8.0 – 23.0	15.0
M10	22.0 – 46.0	30.0

Minimal screw-in depth for aluminum and zinc die-casting parts: 1.5 x Da

Version with floating bearing in z-direction

- ① Rail
 - ② Slide elements
 - ③ Carriage with fixed bearings
 - ④ Carriage with floating bearings
- LLZ or LLY

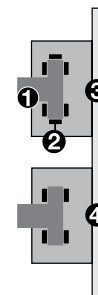

Horizontal version with floating bearing in z-direction

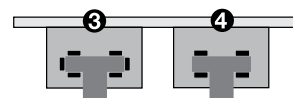

Horizontal version with floating bearing in the y-direction and lateral guide carriage

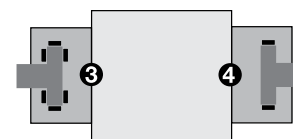

Floating bearing clearances for drylin® T miniature guides

LLZ: Floating bearing in z-direction

LLY: Floating bearing in y-direction

Floating bearing clearances	TW-04-07	TW-04-09	TW-04-12	TW-04-15
LLY	–	0.4	0.5	0.7
LLZ	0.4	0.4	0.5	0.7

drylin® T rail guides | Technical Data

Guide rail	
Material	Aluminum, extruded section
Material	EN AW-6060 T66 or 6063 T6
Coating	Hard-anodized aluminum, 50 µm
Hardness	500 HV
Guide carriages	
Base structure	Aluminum, extruded section
Material	EN AW-6060 T66
Coating	Anodized aluminum
Sliding elements	Maintenance-free plain bearings materials iglide® J, iglide® J200 (TW-12/TW-04-07)
Bolts, springs	Stainless steel
End cap	Plastic (TW-01/TWA-01), steel (TW-02)/TW-03/TW-12
Max. surface speed	5m/s
Temperature range	from -40°F to +194°F

Table 01: drylin® – technical data

Type	C_{0Y} [kN]	$C_{0(-Y)}$ [kN]	C_{0Z} [kN]	M_{0X} [Nm]	M_{0Y} [Nm]	M_{0Z} [Nm]
04-07	0.2	0.2	0.1	1.2	0.6	0.6
04-09	0.48	0.48	0.24	3.4	1.8	1.8
04-12	0.96	0.96	0.48	9.2	4.4	4.4
04-12 (TWE)	0.48	0.48	0.24	4.6	2.2	2.2
04-15	1.4	1.4	0.7	17	8	8
04-15 (TWE)	0.7	0.7	0.35	8.5	4	4
01-/12-15	4	4	2	32	25	25
01-/02-/12-20	7.4	7.4	3.7	85	45	45
01-/02-/03-/12-25	10	10	5	125	65	65
01-/02-/12-30	14	14	7	200	100	100

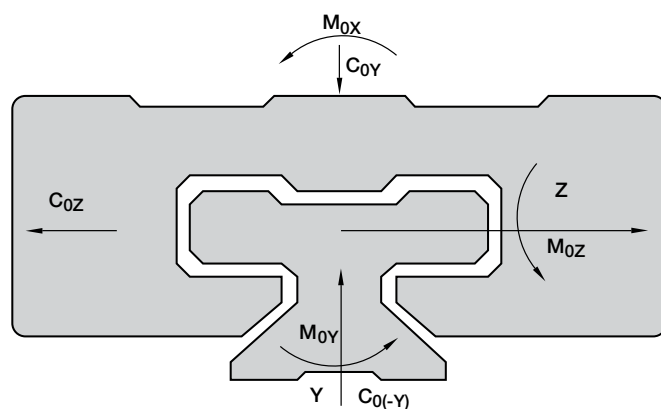

Table 02: drylin® – permissible static load capacity

Diagram 01: Marking of the directions

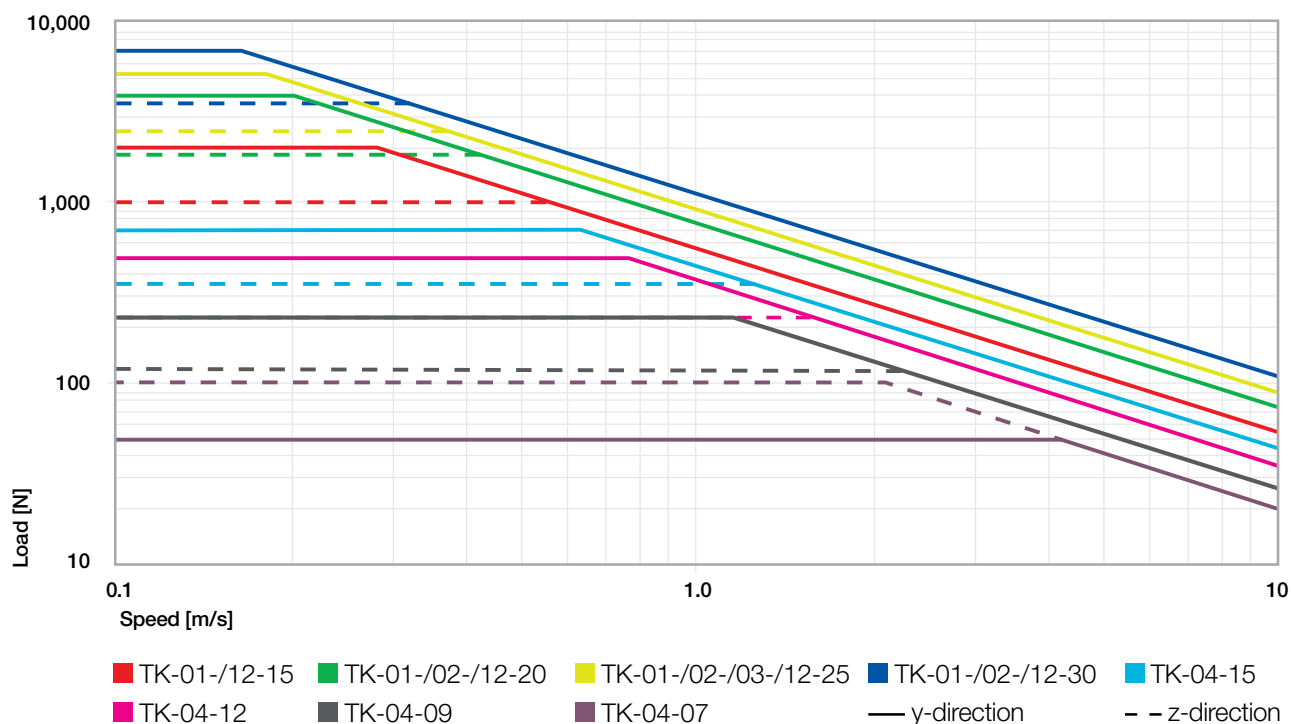

Diagram 02: drylin® T- permissible dynamic load capacity

drylin® T rail guides | Product Range

Guide rails



TS-01



TS-11



Order key

Type	Options
Guide rails	Standard
Installation size	
Rail length [mm]	

TS - 01 - 15 - 1000

Options:

TS-01: Standard rail, hard-anodized

TS-11: hollow rail, clear-anodized

Hard anodized surfaces

► Page 1092

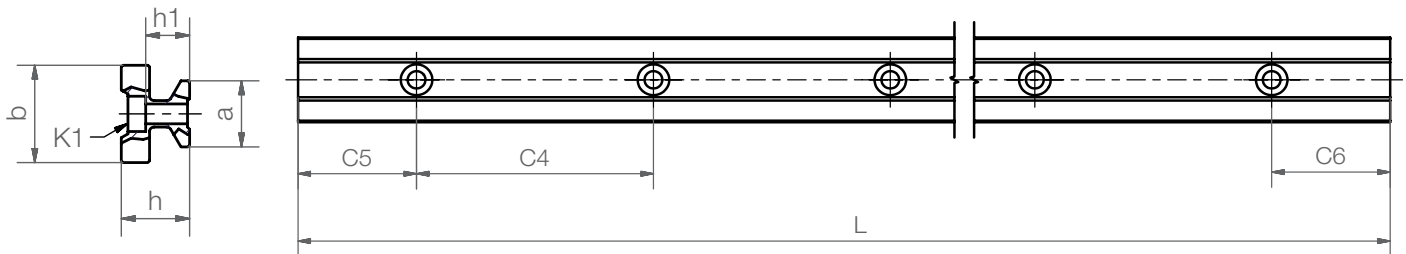

Dimensions [mm]

Part No.	Weight [kg/m]	L Max.	a -0.2	C4	C5		C6		h	h1	K1 for screw DIN 912	b	ly [mm²]	lz [mm²]	Wby [mm²]	Wbz [mm²]
					Min.	Max.	Min.	Max.								
TS-01-15	0.6	4,000	15	60	20	49.5	20	49.5	15.5	10.0	M4	22	6,440	4,290	585	488
TS-01-20	1.0	4,000	20	60	20	49.5	20	49.5	19.0	12.3	M5	31	22,570	11,520	1,456	1,067
TS-11-20	0.5	4,000	20	120	20	79.5	20	79.5	19.0	12.3	M5	31	12,140	6,360	780	620
TS-01-25	1.3	4,000	23	60	20	49.5	20	49.5	21.5	13.8	M6	34	34,700	19,300	2,041	1,608
TS-01-30	1.9	4,000	28	80	20	59.5	20	59.5	26.0	15.8	M8	40	70,040	40,780	3,502	2,832

Standard hole pattern symmetric C5 = C6

For rails without mounting holes, please use part number suffix "S"

Can be combined with:



TW-01-...



TWA-01-...



TW-01-HKA



TW-02-...



TW-03-...



Technical data

► Page 1191

drylin® T rail guides | Product Range

Guide carriage – manual clearance adjustment



TW-01



Order key

Type	Options
TW - 01 - 15 - LLY	
Guide carriages	Options
Standard	
Installation size	
Floating bearing	

Options:

LLY: Floating bearing in y-direction

LLZ: Floating bearing in z-direction

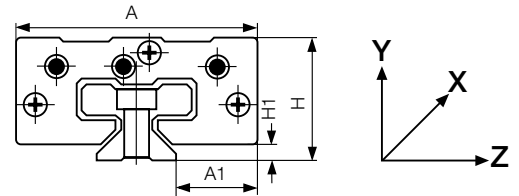
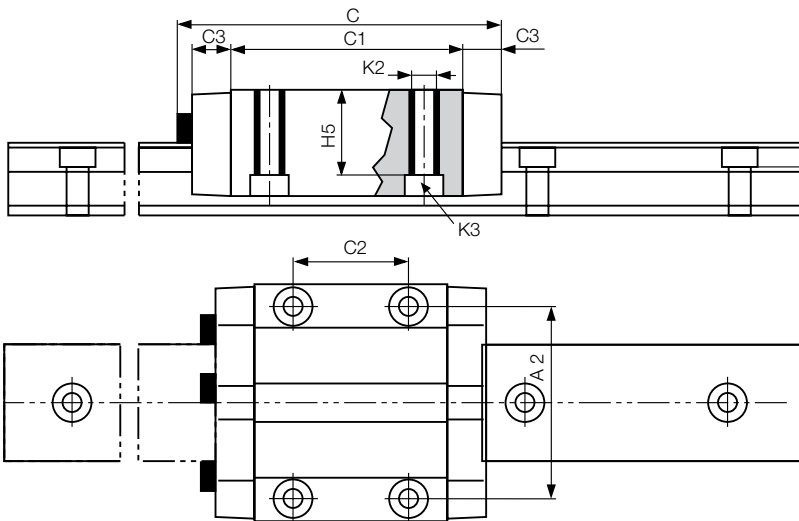

Dimensions [mm]

Part No.	Weight	H	A	C	A1	A2	C1	C2	C3	H1	H5	K2- thread	Tightening torque	K3 for screw
	[kg]	±0.35			±0.35					±0.35			Max.	DIN 912
													[Nm]	
TW-01-15	0.11	24	47	74	16.0	38	50	30	9	4.0	16.0	M5	1.5	M4
TW-01-20	0.19	30	63	87	21.5	53	61	40	10	5.0	19.8	M6	2.5	M5
TW-01-25	0.29	36	70	96	23.5	57	68	45	11	5.0	24.8	M8	6.0	M6
TW-01-30	0.50	42	90	109	31.0	72	79	52	12	6.5	27.0	M10	15.0	M8



All elements can be ordered individually or as assembled systems

TW-01-20-LLY: Standard guide carriage with manually adjustable clearance, installation size 20 and floating bearing in y-direction

Can be combined with:



TS-01-...



Technical data

▶ Page 1191

drylin® T rail guides | Product Range

Guide carriages – automatic clearance adjustment



TWA-01



Order key

Type	Options
TWA - 01 - 15 - LLY	
Guide carriages Automatic version	
Standard	
Installation size	
Floating bearing	

Options:

LLY: Floating bearing in y-direction

LLZ: Floating bearing in z-direction

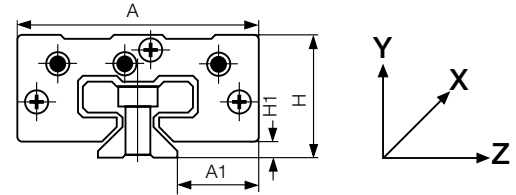
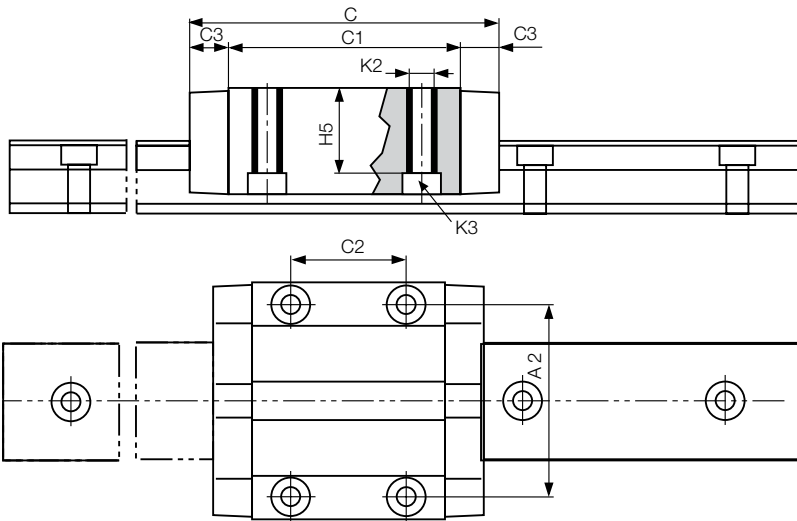

Dimensions [mm]

Part No.	Weight	H	A	C	A1	A2	C1	C2	C3	H1	H5	K2- Weight	Tightening torque Max.	K3 for screw DIN 912
	[kg]	±0.35			±0.35					±0.35			[Nm]	
TWA-01-15	0.11	24	47	68	16.0	38	50	30	9	4.0	16.0	M5	1.5	M4
TWA-01-20	0.19	30	63	81	21.5	53	61	40	10	5.0	19.8	M6	2.5	M5
TWA-01-25	0.29	36	70	90	23.5	57	68	45	11	5.0	24.8	M8	6.0	M6
TWA-01-30	0.50	42	90	103	31.0	72	79	52	12	6.5	27.0	M10	15.0	M8



All elements can be ordered individually or as assembled systems

TW-01-20-LLY: Guide carriage with automatic clearance adjustment, installation size 20 and floating bearing in y-direction

Can be combined with:



TS-01-...



Technical data
▶ Page 1191

drylin® T rail guides | Product Range

High performance carriage with clearance adjustment

drylin® N
low-profile
linear
guides



Order key

Type

TW - 12 - 15

Guide carriages

High performance

Installation size

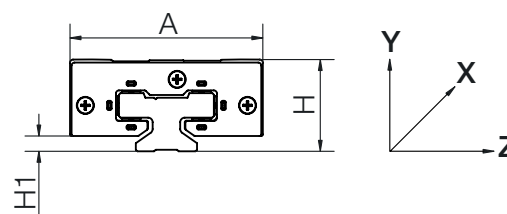
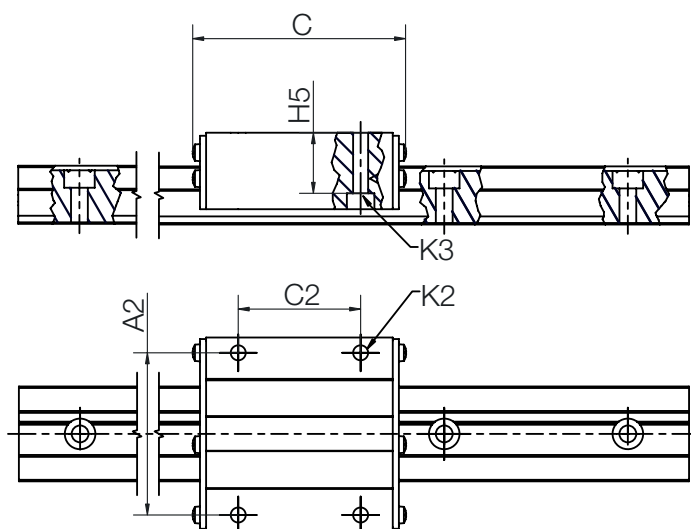

Dimensions [mm]

Part No.	Weight [kg]	H ±0.35	H5	A	C	A2	C2	H1 ±0.35	K2- thread	K3 for cap screw	Sliding elements
TW-12-15	0.11	24	16.0	47	63	38	30	4.0	M5	M4	iglide® J200
TW-12-20	0.19	30	19.8	63	72	53	40	5.0	M6	M5	iglide® J200
TW-12-25	0.29	36	24.8	70	82	57	45	5.0	M8	M6	iglide® J200
TW-12-30	0.50	42	27.0	90	94	72	52	6.5	M10	M8	iglide® J200

Can only be combined with:



TS-01-...



TS-11-...



Technical data

► Page 1191

drylin® T rail guides | Product Range

Guide carriage – with manual clamp



TW-01-HKA

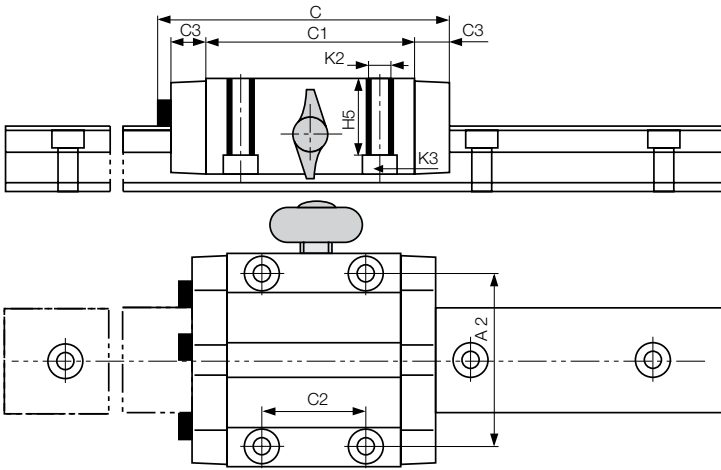

Dimensions [mm]

Part No.	Size	Kz	Ky	Dk	Manual clamp thread
TW-01-15-HKA	15	19.0	11.5	20.0	M6
TW-01-20-HKA	20	18.0	15.0	28.0	M8
TW-01-25-HKA	25	17.0	19.0	28.0	M8
TW-01-30-HKA	30	20.0	21.5	28.0	M8



Order key

Type Options

TW - 01 - 15 - HKA

Guide carriages

Standard

Installation size

Manual clamp



Other dimensions as standard design
TW-01-... ► Page 1193



All elements can be ordered individually or as assembled systems

TW-01-20-HKA: Guide carriage with manually adjustable clearance, installation size 20 and manual clamp



The manual clamp thread was developed for simple tasks. The creep behavior of the clamped plastic causes a reduction in clamping force over time (up to 70%). Therefore no safety-relevant parts may be clamped. Please contact our technical consultant, if you require other options for the clamping.

Can be combined with:



TS-01-...



Technical data

► Page 1191

1196 Lifetime calculation, configuration and more ► www.igus.com/drylinT

drylin® T rail guides | Product Range

Guide carriage – heavy duty for extreme conditions



TW-02



Order key

Type

TW - 02 - 20

Guide carriages

Heavy duty

Installation size

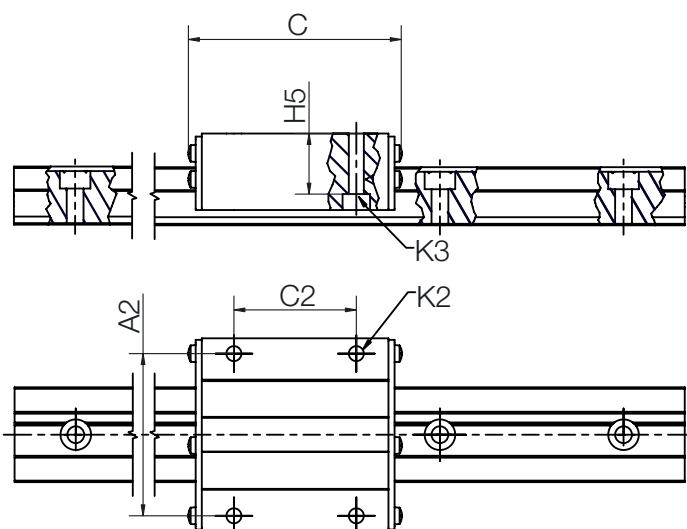

Floating bearing upon request

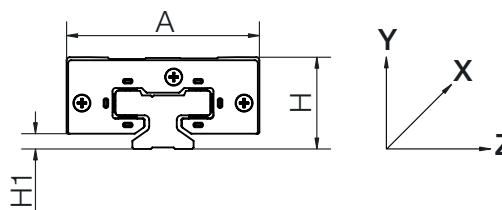

Dimensions [mm]

Part No.	Weight [kg]	H ±0.35	H5	A	C	A2	C2	H1 ±0.35	K2	K3
TW-02-20	0.19	30	19.8	63	70	53	40	5.0	M6	M5
TW-02-25	0.29	36	24.8	70	77	57	45	5.0	M8	M6
TW-02-30	0.50	42	27.0	90	92	72	52	6.5	M10	M8



All elements can be ordered individually or as assembled systems

TW-02-20: Heavy duty guide carriage, installation size 20

Can be combined with:



TS-01-...



Technical data

► Page 1191

drylin® T rail guides | Product Range

Compact for tough applications



TW-03



Order key

Type

TW - 03 - 25

Guide carriages

Reduced weight

Installation size

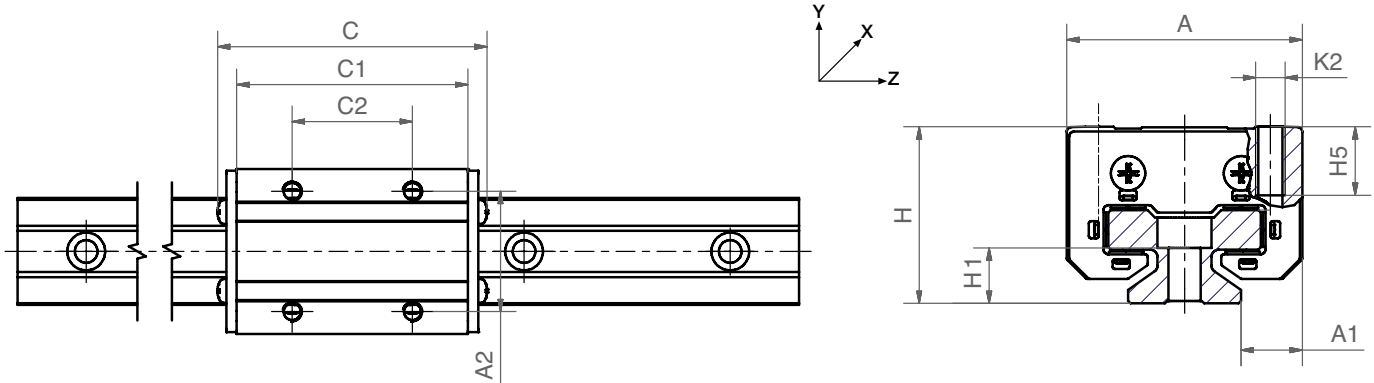

Dimensions [mm]

Part No.	Weight	H	A	C	A1	A2	C1	C2	H1	H5	K2	Tightening torque
	[kg]	±0.35						±0.35				Max.
												[Nm]
TW-03-25	0.16	36	48	81	14	35	67.4	35	5	13	M6	6.0



All elements can be ordered individually or as assembled systems

TW-03-25: Compact guide carriage, installation size 25

Can only be combined with:



TS-01-20



TS-11-20



Technical data

► Page 1191

Compact design

Plastic clamping elements

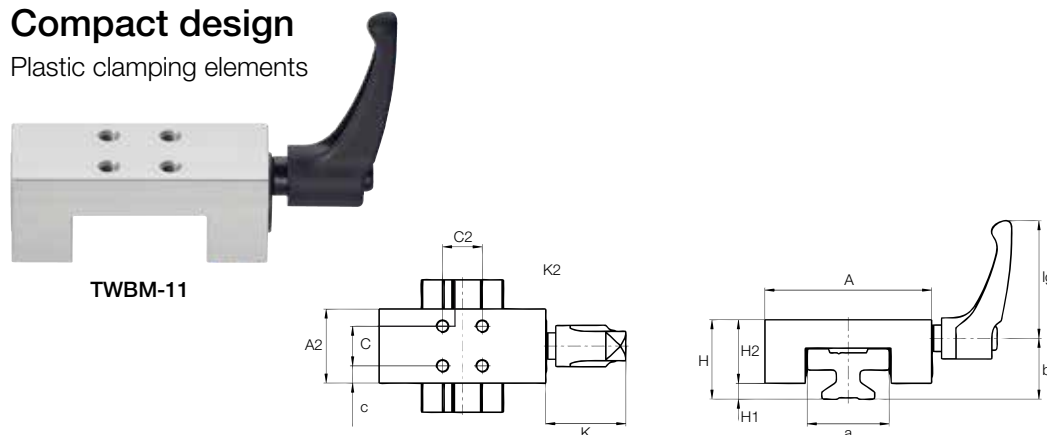

TWBM-11



Order key

Type

TWBM - 11 - 15

Manual clamp

Compact

Installation size

Dimensions [mm]

Part No.	Clamp force [N]	A	a	A2	H	H1	H2	K	K2	C	C2	c	lg	b
TWBM-11-15	180	47	22	23	24	4	20	30	M4	15	15	4	44	18.9
TWBM-11-20	180	63	31	28	30	5	24	30	M5	15	15	6.5	44	23.0
TWBM-11-25	400	70	34	35	36	5	31	39	M6	20	20	7.5	63.63	26.2
TWBM-11-30	500	90	40	38	42	6.5	35.5	47	M6	20	20	9	78	32.4

Standard design

with brass clamp

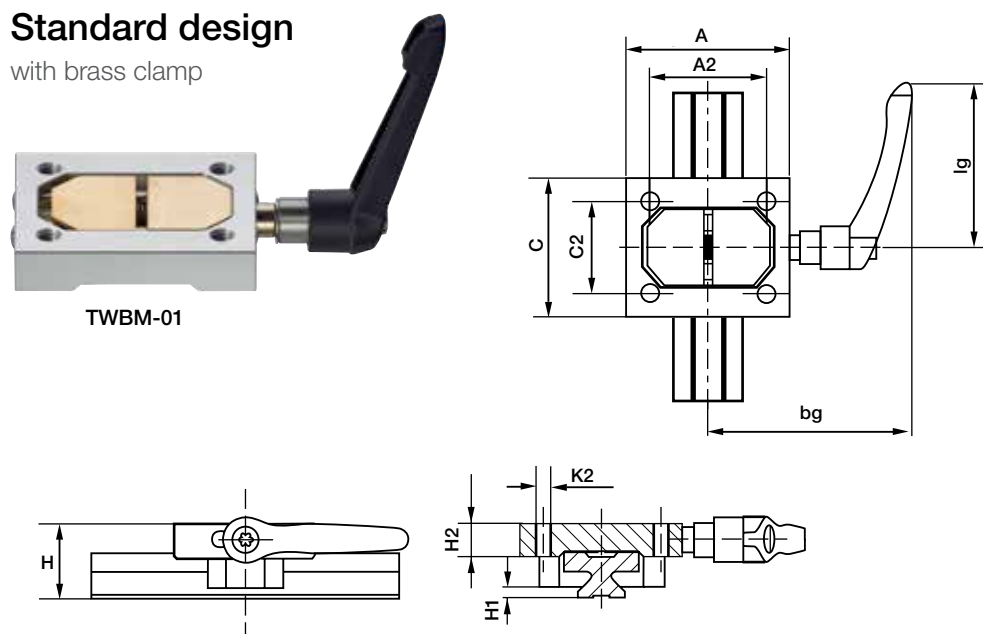

TWBM-01



Order key

Type

TWBM - 01 - 25

Manual clamp

Standard

Installation size

Dimensions [mm]

Part No.	Clamp force [N]	A	A2	H	H1	H2	K2	C	C2	lg	bg
TWBM-01-25	500	80	57	36	5	16	M8	68	45	80	99

Can only be combined with:



TS-01-...

drylin® T rail guides | Product Range

Miniature guide rails



TS-04

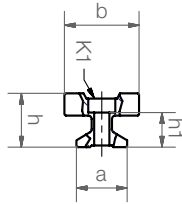
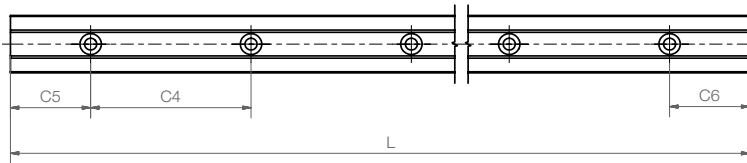

Order key

Type

TS - 04 - 07

Guide rail

Miniature

Installation size

Dimensions [mm]

Part No.	Weight [kg/m]	L	a	C4	C5		C6		h	h1	K1 for screw DIN 912	b	ly [mm²]	lz [mm²]	Wby [mm²]	Wbz [mm²]
					Min.	Max.	Min.	Max.								
TS-04-07	0.08	2,000	7	15	5	12	5	12	5.5	3.7	M2	8	131	90	32	29
TS-04-09	0.11	2,000	9	20	5	14.5	5	14.5	6.3	4.6	M2	9.6	252	169	52	49
TS-04-12	0.20	2,000	12	25	5	17.0	5	17.0	8.6	5.9	M3	13	856	574	132	120
TS-04-15	0.33	3,000	15	40	10	29.5	10	29.5	10.8	7.0	M3	17	2,420	1,410	285	239

Miniature guide carriage – standard



TW-04

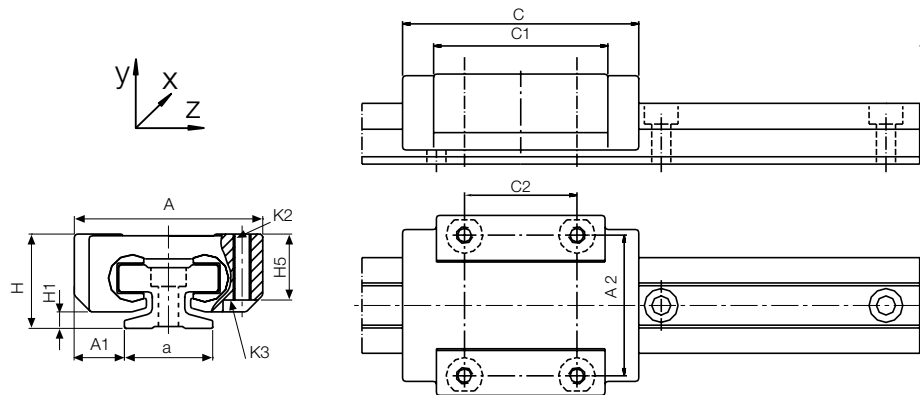

Dimensions [mm]

Part No.	Weight [g]	H ±0.2	A -0.2	C ±0.3	A1 ±0.35	A2	C1	C2	H1 ±0.35	H5	K2 thread	tightening torque [Nm]	K3 for screw DIN 912
TW-04-07	8	8	17	23	5	12	21	8	1.5	-	M2	0.25	-
TW-04-09	17	10	20	29	5.5	15	18	13	1.7	7.2	M2	0.25	M2
TW-04-12	34	13	27	34	7.5	20	22	15	2.2	9.5	M3	0.50	M2 (M3) ^m
TW-04-15	61	16	32	42	8.5	25	31	20	2.8	11	M3	0.50	M2 (M3) ^m

^m (M...) = bored out

drylin® T rail guides | Product Range

Adjustable miniature guide carriage

 **Order key**

Type
TW E - 04 - 12

Guide carriages
Adjustable clearance
Miniature
Installation size



TWE-04

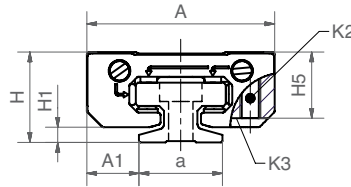

 E-coated for high corrosion resistance

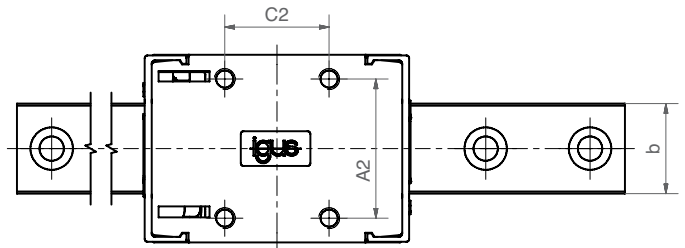
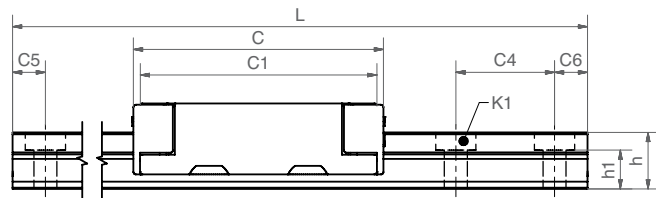

Dimensions [mm]

Part No.	Weight	H	A	C	A1	A2	C1	C2	H1	H5	K2 thread	K3 for screw
	[g]	±0.2	-0.2	±0.3	±0.35				±0.35			DIN 912
TWE-04-12	36	13	27	38	7.5	20	36	15	2.2	9.5	M3	M2
TWE-04-15	61	16	32	45	8.5	25	31	20	2.8	11	M3	M2

-  Clearance adjustment steps:
1. Press the screw in with light force
 2. Turn left or right to increase or decrease clearance
 3. Remove screwdriver



Tool: screwdriver with 3mm edge wide



Right side: setting the height clearance



Left side: setting the lateral clearance

Can be combined with:



TS-04-...



Technical data

► Page 1191

drylin® T rail guides | Ordering options



drylin® T replacement plastic slide elements (set)
 iglide® J material ▶ Page 193
 iglide® A180 material ▶ Page 493

Guide carriages	Part No. Sliding part set
TW-01-15	TEK-01-15
TW-01-20	TEK-01-20
TW-01-25	TEK-01-25
TW-01-30	TEK-01-30
TW-02-20	TEK-02-20
TW-02-25	TEK-02-25
TW-02-30	TEK-02-30
TW-12-20	TEK-12-20
TW-04-09	TEK-04-09
TW-04-12	TEK-04-12
TW-04-15	TEK-04-15



drylin® T end caps for series 01 guide rail holes:

Rail	Part No. End cap
TS-01-15	TSZ-011501
TS-01-20	TSZ-012001
TS-01-25	TSZ-012501
TS-01-30	TSZ-013001

When using the end caps, screws with a low screw head must be used to attach the rail.

drylin® T – system design

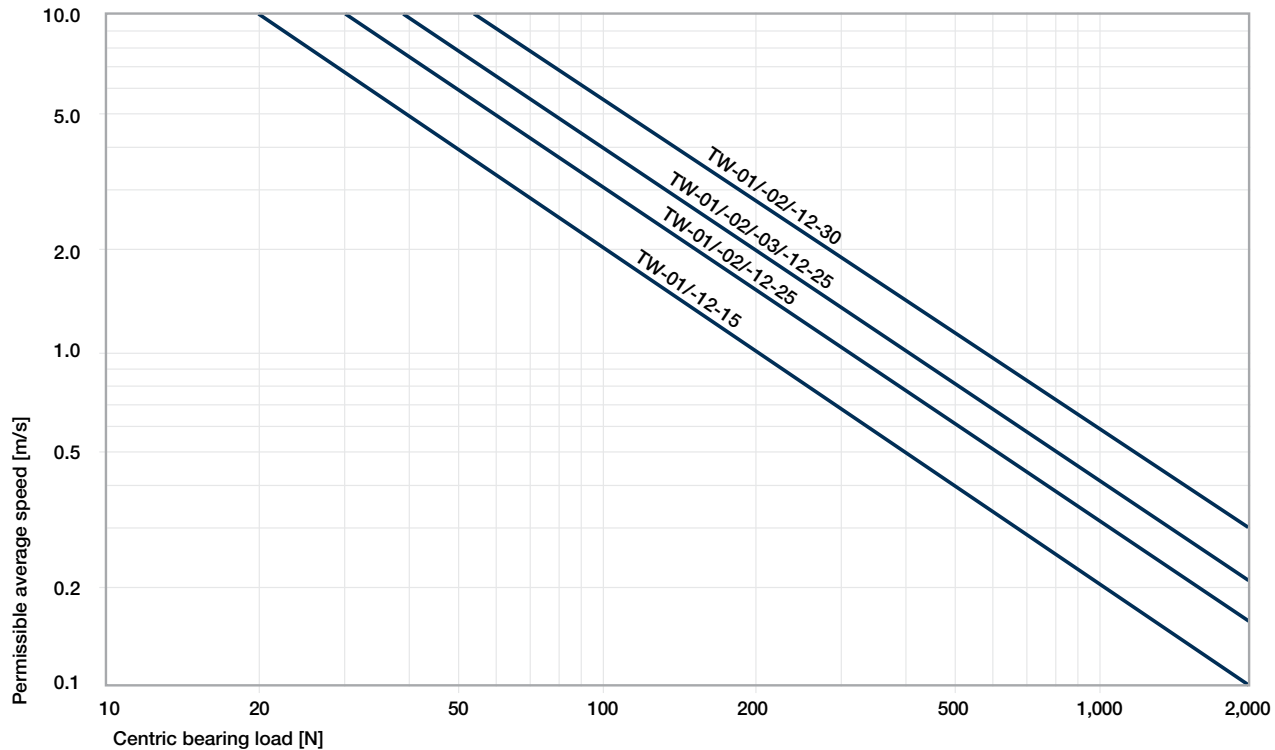

Diagram 04: Determination of the maximum permitted speed for the load

Part No.	F _{ymax.} , F _{zmax.} [N]
TW-01/-12-15	2,000
TW-01/-02/-12-20	3,700
TW-01/-02/-03/-12-25	5,000
TW-01/-02/-12-30	7,000



drylin[®] linear technology – drylin[®] R shaft guides

Inch and metric options

Self-lubricating drylin[®] liners

Resistance to dust and dirt

Low coefficient of friction

Extremely quiet operation

Many adapter and housing options



drylin® R shaft guides | Advantages

Extremely wear-resistant, robust in challenging environments and lightweight



Hard-anodized aluminum shafts guarantee optimum running properties

Shafts made from steel, stainless steel or carbon fiber

Shafts and supported shafts available

Linear adapter made from solid plastic or aluminum

Complete housing made from anodized aluminum

drylin® liners made from five different self-lubricating iglide® high-performance polymers

Hard-anodized aluminum tubes – lightweight

Self-lubricating shaft guides – drylin® R

drylin® R shaft guides are based on extremely wear-resistant polymers specially developed for the linear technology. The dimensions are compatible with standard ball bearings. The special geometry guarantees reliability even in extreme environments.

- 100% self-lubricating
- Dimensionally interchangeable with standard recirculating ball bearings
- Shafts, shaft end blocks and accessories available from stock
- Replaceable liners

Typical application areas

- Agricultural machinery
- 3D printing
- Medical technology
- Packaging industry



Available from stock

Detailed information about delivery time online.



Price breaks online

No minimum order value. No minimum order quantity.



Up to Ø 2" / 60 mm

More dimensions upon request.



Service life calculation

► www.igus.com/drylin-expert



Cleanroom certificated
IPA Fraunhofer



Free from toxins
2011/65/EU (RoHS)



ESD-compatible
(electrostatic discharge)

drylin® R shaft guides | Product overview

Dimensions correspond to standard for recirculating ball bearings with replaceable liners



Liners

- Made from iglide® high-performance polymers
- Easy to assemble
- Unaffected by dirt and dust
- Low coefficient of friction, optimized wear quality

Inch sizes ► Page 1214

Metric sizes ► Page 1252



Linear plain bearings

- Dimensionally interchangeable with standard recirculating ball bearings
- Extremely lightweight solid plastic bearing
- Aluminum and stainless steel adapters

Inch sizes ► Page 1224

Metric sizes ► Page 1271



Closed pillow blocks

- Pre-assembled linear housing with drylin® liners
- Material: Anodized aluminum
- Fixed and floating bearing version available

Inch sizes ► Page 1246

Metric sizes ► Page 1290



Linear bearings and pillow blocks, open design

- For supported shafts
- Round or with housing
- Clearance adjustment (optional)

Inch sizes ► Page 1247

Metric sizes ► Page 1297



Flanged linear plain bearings

- Pre-assembled housings with drylin® liners
- Round or square flange
- Tandem flange housing for additional stability

Inch sizes ► Page 1250

Metric sizes ► Page 1301

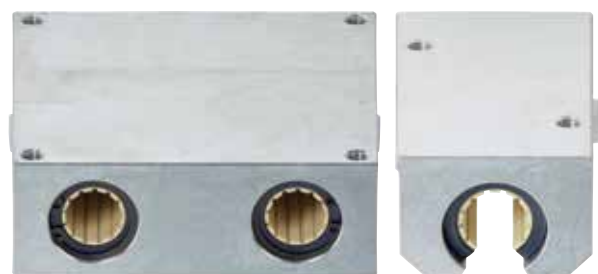

Quad block

- Closed and open design
- Torque-resistant quad block housing with four linear adapters

● Also available as tandem housing

► Page 1306

drylin® R shaft guides | Application examples

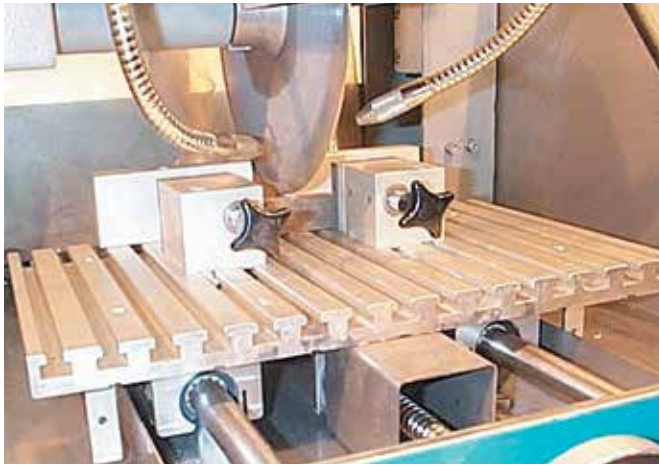

drylin® R linear plain bearings on supported aluminum shafts are used in this grinder to guide the cutting table. The drylin® components stand for extreme dirt resistance, accurate guidance and smooth operation.



Saw mill: linear guide with iglide® J plastic liner for the angle stops. iglide® J liners are best suited for most linear applications due to their low wear and low friction properties.



The machine now runs entirely free of troubles for multiple years with drylin® RJUM-01 linear bearings despite the extremely heavy – duty operation.



By changing over to the drylin® R linear plain bearing, the maintenance rate of this compaction unit could be extended by two years, despite high stressing from powder particles and abrasive agents.



Since the sliding bearing should be maintenance-free, precise, compact, durable and very resilient, liners were mounted directly in the passages of the machine frame.



The production line should be adjusted without setup time being required. drylin® linear guides, which enable precise and fast adjustment, were used for this.



Expert for linear guides: System selection & service life calculation with CAD

Configure linear bearings and calculate their service life – constantly expanded by new sizes and products

Easily calculate the service life of your required linear guide and configure with a few clicks. Select a drylin® system and add the relevant environmental parameters. Select the bearing size, carriage, number and position. Then enter the distance between the rails and the mounting. Define more relevant parameter of the guidance and select a rail length. The results are displayed.



► www.igus.com/drylin-expert



Download the online tool app now

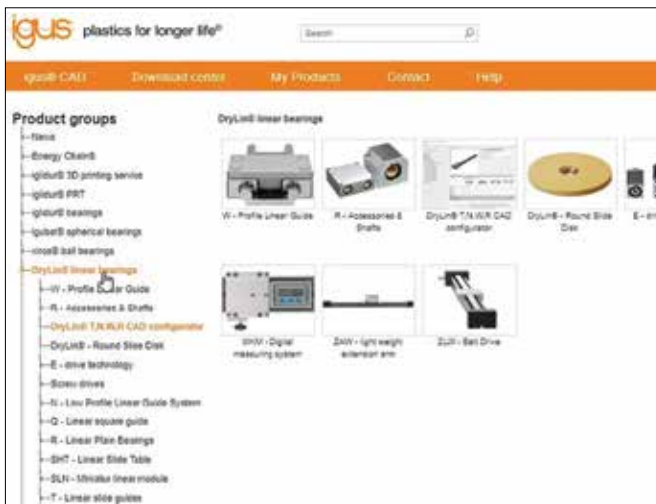

drylin® CAD configurator: Generate complete 3D models for drylin® linear technology according to your specifications

The igus® CAD online configurator gives you the ability to design and save your linear guide as a system, individual components directly as a 3D model in all commonly used formats, or to have these sent by e-mail – free of charge and without registration.



► www.igus.com/drylin-CAD

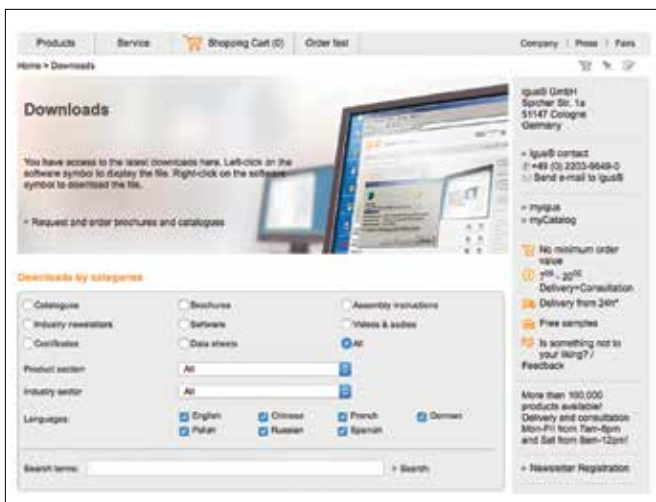

More information about the products can be found in the igus® download area

- Assembly instructions
- Assembly videos
- System design
- Catalogs



► www.igus.com/downloads

drylin® R shaft guides | Technical Data

drylin® R linear plain bearings

The drylin® standard round bearings consist of an interchangeable iglide® J liner that is manufactured to be a mechanical fit into an anodized aluminum adapter. The locating spigot of the liner is carried out by a snap ring groove. drylin® R linear plain bearings, made from solid plastic, are dimensionally equivalent to standard ball bearings. They are made entirely out of wear-resistant iglide® J material and can offer technical advantages in addition to the clear price advantage. Thus, applications in which machine parts are primarily stainless steel, e.g. food and filling equipment, are well suited for the use of solid plastic bearings. An additional weight-saving is also easily obtained.

Both versions are designed for the installation in housing holes with the tolerance H7. The mounting is done like in ball bearings with snap ring according to DIN 471/472.

The narrow design of the 02 series linear plain bearings, is clipped into the H7 housing hole. Standard commercial 2-component adhesives can be used for this purpose.

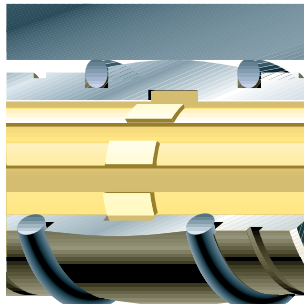







Dirt, dust, fibers

An important feature of all the available linear bearings is their tolerance of dirt. For most systems the application of wipers or seals is recommended for even low dirt accumulation. No other system features such a high safety with dust, lint and coarse dirt as drylin®. The patented design of the bearing surface using individual slide pads connected by thin film sections, provides performance benefits for dirty environments. Dirt, even when it becomes wet on the shaft, is wiped away by the individual glide pads and is moved into the open areas. The running sections of the drylin® bearing then slide on the shaft that has been cleared of all contaminants.

Split linear bearings

Applications that are on the edge of technical feasibility or in extremely harsh environments often require frequent replacement of the bearings. In many cases, drylin® can give a multiple increase in the service life. However, in extreme applications, replacement of the bearings is necessary, even with drylin®. drylin® linear plain bearings can provide considerable cost reductions in such cases as only the polymer bearing liner has to be replaced. This often means a reduction of more than 90% in replacement part costs. In addition the dismantling of the shafts is avoided.



	 The All-rounder – iglide® J	 The specialist – iglide® J200	 The extreme – iglide® X	 The endurance runner – iglide® E7	 The FDA-compliant – iglide® A180	 Blue Sky Thinking FDA/EU-compliant – iglide® A160
Application temperature	from –58°F to +194°F (–50°C to +90°C)	from –58°F to +194°F (–50°C to +90°C)	from –148°F to +482°F (–100°C to +250°C)	from –58°F to +158°F (–50°C to +70°C)	from –58°F to +194°F (–50°C to +90°C)	from –58°F to +194°F (–50°C to +90°C)
Best coefficient of friction with	Steel shaft	Hard-anodized aluminum	Hard-chromed steel	Steel/stainless steel shaft	Stainless steel shaft	Hardened stainless steel shafts
Volume resistance	> 10 ¹⁰ Ωcm	> 10 ¹⁰ Ωcm	< 10 ¹⁰ Ωcm	> 10 ¹⁰ Ωcm	> 10 ¹⁰ Ωcm	> 10 ¹⁰ Ωcm
Moisture absorption	1.3% weight	0.7% weight	0.5% weight	< 0.1% weight	0.2% weight	< 0.1% weight
Maximum service life with	Hard-anodized aluminum	Hard-anodized aluminum	Hardened stainless steel	Steel/stainless steel shaft	Stainless steel shaft	Hardened stainless steel shafts
Potential counter partner	All shaft materials	Hard-anodized aluminum	Hardened stainless steel	Steel/stainless steel shaft	All shaft materials	Stainless steel
Permissible stat. surface pressure	5,076 psi (35MPa)	3,336 psi (23MPa)	21,760 psi (150MPa)	2,611 psi (18MPa)	4,061 psi (28MPa)	2,176 psi (15MPa)
Part No.	JUI / JUM-...	J200UI / J200UM-...	XUI / XUM-...	E7UI / E7UM-...	A180UM-...	A160UM-...

Floating bearings for linear plain bearings

drylin® O3 series linear plain bearings offer great advantages in applications with parallel shafts. With their geometry, they are able to compensate for alignment and parallelism errors and should be used on the shaft located furthest from the drive mechanism. The design provides a spherical area on the outside diameter of the aluminum adapter for self-alignment. Reductions in load capacity are prevented, since the shaft always lies on the total projected surface. Due to the even load distribution over the entire bearing, edge pressure is not possible with the self-aligning drylin® linear bearings. In order to compensate parallelism errors between two shafts, the outer diameter is designed to be smaller than the housing hole diameter by 0.2 to 0.3mm (depending on the size). With the use of mounted O-rings, these bearings have an elastic bearing seat. The clearance between the bearing and housing allows for the maximum compensation of possible shaft miss-alignment.

The drylin® R self-aligning bearings are supplied hard-anodized. These surfaces guarantee the highest wear resistance if the aluminum bearing moves in the housing during compensation adjustments. Another option are the pillow blocks in the OJUM-06 LL and RJUM-06 LL design series. The mounting of the bearing allows a parallelism adjustment between the shafts by $\pm 3\text{mm}$. The particular suspension of the supporting housing on an axis running in the z-direction enables an angular error compensation of up to 3.5° .

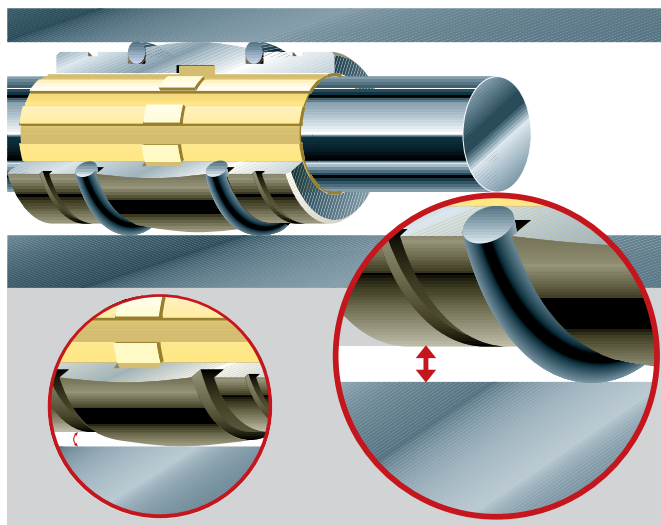

Diagram 02: By defined installation clearance and externally mounted O-rings, the self-aligning drylin® R bearings of the type series 03 can compensate parallelism errors. The spherical drylin® adapter can compensate for parallelism errors. A hard-anodization protects the aluminum adapter from wear.

The 2:1 Rule

When using linear plain bearings it is important to ensure that the acting forces follow the 2:1 Rule (see drawing). If either the load or the drive force (F) is greater than twice the bearing length ($1X$), then a binding or interrupted motion may occur.

If the location of the drive force or load cannot be changed, simply increase the distance between the bearings, or create a counterbalance to move the center-of-gravity back within the 2 to 1 ratio.

2:1 Rule = permissible distances of the applied forces

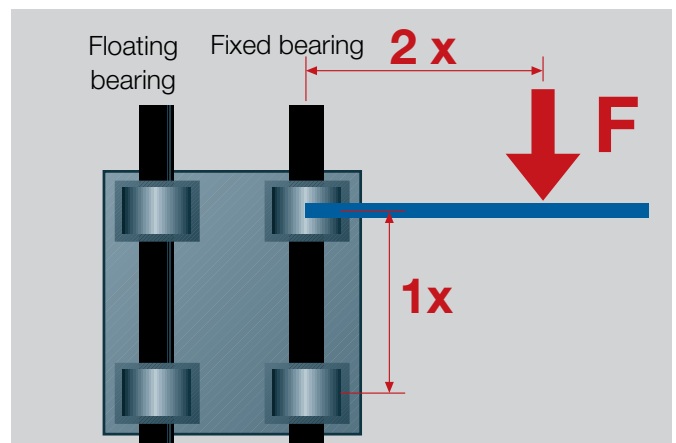
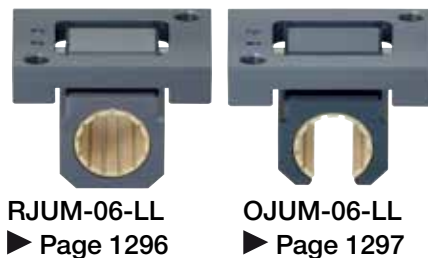

Figure 03: The 2:1 rule



RJUM-03/OJUM-03 series	$\pm 0.5^\circ$
RJUM-06-LL/OJUM-06-LL series	$\pm 3.5^\circ$

Table 04: Compensation of misalignment errors

RJUM-03/OJUM-03 series	$\pm 0.1\text{mm}$
RJUM-06-LL/OJUM-06-LL series	$\pm 3.0\text{mm}$

Table 05: Compensation of parallelism errors

drylin® R shaft guides | igus® testing method

igus® testing method for measuring the tolerance of drylin® plain bearings

In order to ensure the function of the drylin® linear plain bearing, it is necessary to use the bearing with a defined clearance. The quality control of this product line is performed with a cylinder gauge test. For this purpose, a certain force is defined, with which the cylinder gauge is loaded when the plain bearing is tested.

Part No.	Test force [N]	Øi test housing	Min. bearing Øi (c. gauge-free)	Max. bearing Øi (with c. gauge)
J / J200 / E7 / A180 / A160UM-01/02-10	0.981	12.000 mm	10.030 mm	10.070 mm
J / J200 / E7 / A180 / A160UM-01/02-12	1.373	14.000 mm	12.030 mm	12.070 mm
J / J200 / E7 / A180 / A160UM-01/02-16	1.864	18.000 mm	16.030 mm	16.070 mm
J / J200 / E7 / A180 / A160UM-01/02-20	2.649	23.000 mm	20.030 mm	20.070 mm
J / J200 / E7 / A180 / A160UM-01/02-25	3.729	28.000 mm	25.030 mm	25.070 mm
J / J200 / E7 / A180 / A160UM-01/02-30	4.807	34.000 mm	30.040 mm	30.090 mm
J / J200 / E7 / A180 / A160UM-01/02-40	7.063	44.000 mm	40.040 mm	40.090 mm
J / J200 / E7 / A180 / A160UM-01/02-50	9.810	55.000 mm	50.050 mm	50.100 mm
J / J200 / E7UM-01/02-650	13.047	65,000 mm	60.050 mm	60.150 mm
JUI-01-06	0.981	0.4684 Inch	0.3768 Inch	0.3776 Inch
JUI-01-08	1.373	0.5934 Inch	0.5016 Inch	0.5024 Inch
JUI-01-10	1.864	0.7184 Inch	0.6268 Inch	0.6276 Inch
JUI-01-12	2.649	0.8747 Inch	0.7516 Inch	0.7524 Inch
JUI-01-16	3.729	1.1247 Inch	1.0016 Inch	1.0024 Inch
JUI-01-20	4.807	1.4058 Inch	1.2520 Inch	1.2531 Inch
JUI-01-24	7.063	1.6558 Inch	1.5020 Inch	1.5031 Inch
JUI-01-32	9.810	2.1870 Inch	2.0024 Inch	2.0039 Inch
RJM / RJMP / RJ4JP-01-08	0.981	16.000 mm	8.025 mm	8.061 mm
RJM / RJMP / RJ4JP-01-10	0.981	19.000 mm	10.025 mm	10.061 mm
RJM / RJMP / RJ4JP-01-12	1.373	22.000 mm	12.032 mm	12.075 mm
RJM / RJMP / RJ4JP-01-16	1.864	26.000 mm	16.032 mm	16.075 mm
RJM / RJMP / RJ4JP-01-20	2.649	32.000 mm	20.040 mm	20.092 mm
RJM / RJMP / RJ4JP-01-25	3.729	40.000 mm	25.040 mm	25.092 mm
RJM / RJMP / RJ4JP-01-30	4.807	47.000 mm	30.040 mm	30.092 mm
RJM / RJMP-01-40	7.063	62.000 mm	40.050 mm	40.112 mm
RJI-01-06	0.981	0.6250 Inch	0.3762 Inch	0.3776 Inch
RJI-01-08	1.373	0.8750 Inch	0.5013 Inch	0.5030 Inch
RJI-01-10	1.864	1.1250 Inch	0.6265 Inch	0.6282 Inch
RJI-01-12	2.649	1.2500 Inch	0.7516 Inch	0.7536 Inch
RJI-01-16	3.729	1.5625 Inch	1.0035 Inch	1.0056 Inch
RJI-01-20	4.807	2.0000 Inch	1.2520 Inch	1.2544 Inch
RJI-01-24	7.063	2.3750 Inch	1.5020 Inch	1.5044 Inch
RJI-01-32	9.810	3.0000 Inch	2.0024 Inch	2.0053 Inch
RJ260(U)M-02-12	1.373	19.000 mm	12.032 mm	12.084 mm
RJ260(U)M-02-16	1.864	24.000 mm	16.032 mm	16.084 mm
RJ260(U)M-02-20	2.649	28.000 mm	20.040 mm	20.100 mm
RJ260(U)M-02-25	3.729	35.000 mm	25.040 mm	25.100 mm

drylin® R shaft guides | igus® testing method

Part No.	Test force [N]	Øi test housing	Min. bearing Øi (c. gauge-free)	Max. bearing Øi (with c. gauge)
XUMO-01-10	0.981	12.000 mm	9.98 mm	10.02 mm
XUM-01/02-12	1.373	14.000 mm	12.02 mm	12.06 mm
XUM-01-14	1.5	16.000 mm	14.02 mm	14.06 mm
XUM-01/02-16	1.864	18.000 mm	16.02 mm	16.06 mm
XUM-01/02-20	2.649	23.000 mm	20.03 mm	20.07 mm
XUM-01/02-25	3.729	28.000 mm	24.97 mm	25.01 mm
XUM-01/02-30	4.807	34.000 mm	29.96 mm	30.01 mm
XUM-01/02-40	7.063	44.000 mm	40.00 mm	40.05 mm

Explanation:

The iglide® X material has a higher stiffness than iglide® J. This causes shifts – depending on the diameter – compared to the ratio of test force to LD diameter. The parts are designed in such a way that under load the clearance between the iglide® X and iglide® J bearings is as identical as possible. Thereby in the use of iglide® X liners, increased shifting forces can occur in the unloaded new condition on an h-toleranced shaft.

When using a plain bearing (JUM/RJM) in connection with a housing (RJUM, OJUM, RGA) the factory tolerance of the housing bore (standard case: H7) is also added to the minimum clearance stated above. The total from these two values then produces the maximum possible bearing tolerance.

The effective clearance is also influenced by the shaft tolerance. The maximum shaft undersize value should be added to give the maximum possible clearance.

Fmax dynamic:

The maximum values are the result of the projected surface and 5 MPa surface pressure.

Fmax static:

The maximum values are the result of the projected surface and 35 MPa surface pressure.



Installation instructions ► 1212

Tightening torque for drylin® connections between metal parts

Metric thread (Da)	Torque [Nm]	Recommended torque [Nm]
M3	0.5 - 1.1	0.7
M4	1.0 - 2.8	1.5
M5	2.0 - 5.5	3.0
M6	4.0 - 10.0	6.0
M8	8.0 - 23.0	15.0
M10	22.0 - 46.0	30.0

Note the minimal screw in depth for aluminum and zinc parts: 1.5 x Da

*X is the European equivalent material for iglide® X

drylin® R shaft guides | Installation instructions

drylin® R shaft guides are designed for completely self-lubricating operation. The dimensions of the respective linear adapter and housing meet the standard for recirculating ball bearings. During assembly, please note the following installation instructions:

Design tips for drylin® linear plain bearings:

The mentioned values for "F_{max}." relate to the performance of the iglide® liners made from high-performance plastics and cannot be used as the only selection tool for the calculation of an application. The maximum carrying capacity of the entire bearing system depends on the geometry, housing shape, the housing material, the connection including the screws used and requires a separate inspection. For a detailed analysis, please use our online configurator at

► www.igus.com/drylin-expert

Recommended tolerance for the shaft: h6-h10

Surface roughness [Ra]: 0.15-0.6

Guide shafts round/supported

Inch shaft ► Page 1316

Metric shaft ► Page 1326



Liners:
_UI-01, _UIO-01, _UM-01,
_UMO-01, _UM-20, _UMO-20,
_UM-02



Linear plain bearings:
R_UI-01, R_UI-03, R_UI-21
T_UI-01, T_UI-03
R_UM-01, R_UM-21, R_UM-ES,
T_UM-01, R_UM-03, T_UM-03,



Solid plastic bearings:
RJM, RJJ



Solid plastic bearings:
RJIP, RJMP



Linear plain bearings:
RJUM-02



Compact bearings:
RJ260(UM-02)



Linear plain bearings:
OJUI-01, OJUI-03,
OJUM-01, OJUM-03

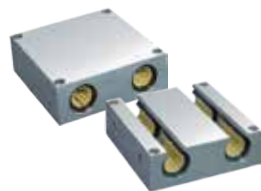

Quad blocks:
RQA, OQA



Aluminum pillow blocks:
RTA, OTA, RGA, OGA, RGAS,
OGAS



Flanged pillow blocks:
FJUI-XX, FJUI-XX TW, FJUIT
FJUM-01/02, FJUMT-01,



Anodized aluminum
pillow blocks:
RJUI-XX, OJUI-XX,
RJUI-XX TW, OJUI-XX TW,
RJUM-05/06, OJUM-05/06,
RJUME-05, RJUMT-05,
TJUM-05, OJUME-06
RJUM / OJUM-06-XX-LL

Notes

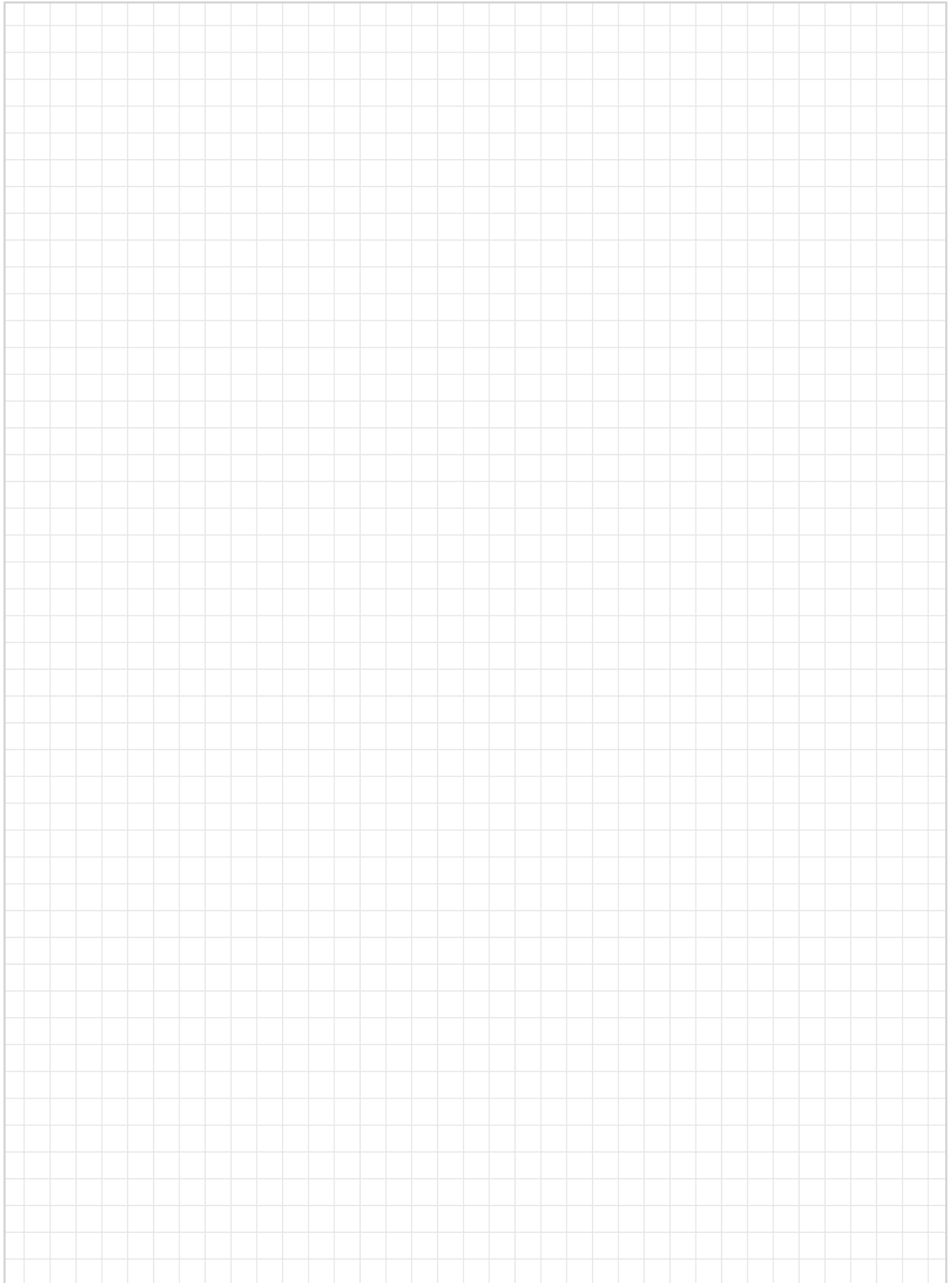

drylin® R liners | Product Range

Closed design for unsupported shafts – made from iglide® J

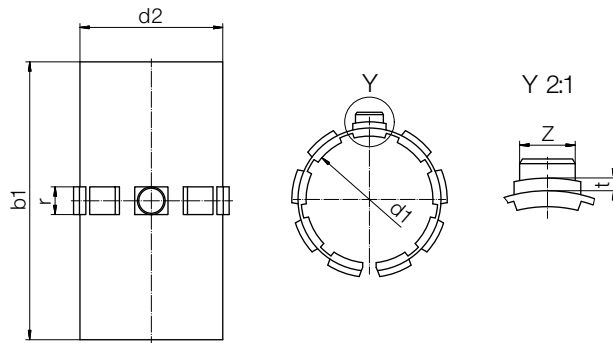

Order key

Type	Size
J U I -01 -10	
iglide® J	
Liner	
Inch	
Standard	
Inner Ø d1	

Best Shaft Material: drylin® AWI hard anodized aluminum, case hardened steel, 300 series stainless, 400 series stainless, hard chrome plated steel

Maximum static psi = 5,076 (35MPa)



⁷⁸⁾ According to igus® testing method ▶ Page 1210
Please note: Installation instructions ▶ Page 1212



Min. -58°F (-50°C)
Max. +194°F (+90°C)

Dimensions [inch]

Part No.	Nominal Size	Tolerance ⁷⁸⁾	d2	b1	r	t	z
					-0.004 -0.008	-0.004	-0.020
JUI-01-06	3/8	.0016-.0024	0.4684	0.846	.1250	.0311	.0866
JUI-01-08	1/2	.0016-.0024	0.5934	1.220	.1250	.0391	.1024
JUI-01-10	5/8	.0016-.0024	0.7184	1.460	.1406	.0391	.1181
JUI-01-12	3/4	.0016-.0024	0.8747	1.575	.1875	.0391	.1339
JUI-01-16	1	.0016-.0024	1.1247	2.205	.1875	.0391	.1496
JUI-01-20	1 1/4	.0020-.0032	1.4058	2.573	.1875	.0391	.1496
JUI-01-24	1 1/2	.0020-.0032	1.6558	2.953	.2500	.0625	.1811
JUI-01-32	2	.0024-.0040	2.1871	3.937	.2813	.0625	.2280

Installation drawings housing bore for Liner JUI-01

Dimensions [inch]

Part No.	Nominal Size	di Max.	di Min.	B *h10	r +0.002	t +0.004	f +0.02	z +0.008
JUI-01-06	3/8	.4680	.4684	.875	.1250	.031	.039	.102
JUI-01-08	1/2	.5940	.5934	1.250	.1250	.0391	.059	.122
JUI-01-10	5/8	.7190	.7184	1.500	.1406	.0391	.067	.142
JUI-01-12	3/4	.8755	.8747	1.625	.1875	.0391	.079	.142
JUI-01-16	1	1.1255	1.1247	2.250	.1875	.0391	.079	.161
JUI-01-20	1 1/4	1.4068	1.4058	2.625	.1875	.0391	.079	.161
JUI-01-24	1 1/2	1.6568	1.6558	3.000	.2500	.051	.098	.200
JUI-01-32	2	2.1881	2.1871	4.000	.2813	.051	.098	.240

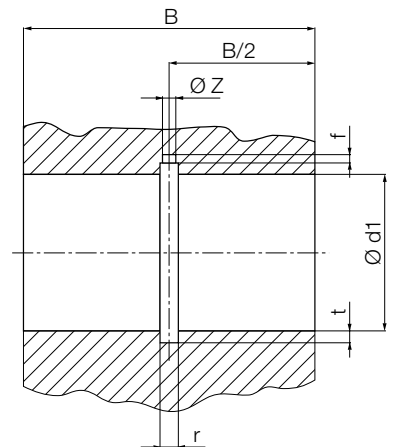

Can be combined with:



RJUI-01/-03



TJUI-01/-03

drylin® R liners | Product range

Open design for supported shafts – made from iglide® J

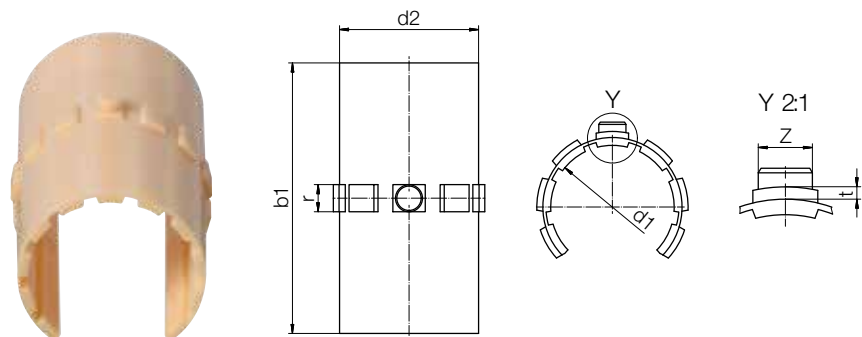



Order key

Type	Size
J U I O -01 -10	
iglide® J	
Liner	
Inch	
Open	
Standard	
Inner Ø d1	

Best Shaft Material: drylin® AWUI hard anodized aluminum, case hardened steel, 300 series stainless, 400 series stainless, hard chrome plated steel

Maximum static psi = 5,076 (35MPa)

 ⁷⁸⁾ According to igus® testing method ▶ Page 1210
Please note: Installation instructions ▶ Page 1212

 **Min. -58°F (-50°C)**
Max. +194°F (+90°C)

Dimensions [mm]

Part No.	Nominal Size	Tolerance ⁷⁸⁾	d2	b1	W	r	t	z
						-0.004 -0.008	-0.004	-0.020
JUIO-01-06	3/8	.0016-.0024	0.4684	0.846	0.250	.1250	.0311	.0866
JUIO-01-08	1/2	.0016-.0024	0.5934	1.220	0.394	.1250	.0391	.1024
JUIO-01-10	5/8	.0016-.0024	0.7184	1.460	0.433	.1406	.0391	.1181
JUIO-01-12	3/4	.0016-.0024	0.8747	1.575	0.492	.1875	.0391	.1339
JUIO-01-16	1	.0016-.0024	1.1247	2.205	0.630	.1875	.0391	.1496
JUIO-01-20	1 1/4	.0020-.0032	1.4058	2.573	0.709	.1875	.0391	.1496
JUIO-01-24	1 1/2	.0020-.0032	1.6558	2.953	0.866	.2500	.0625	.1811
JUIO-01-32	2	.0024-.0040	2.1871	4.937	1.181	.2813	.0625	.2280

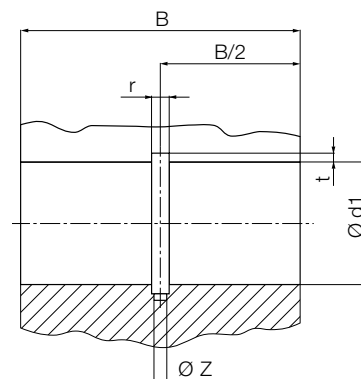

Installation drawings housing bore for Liner JUIO-01

Dimensions [Inch]

Part No.	Shaft Size Ø	di		B	r	t	f	z	W
		Min.	Max.						
JUIO-01-06	3/8	.4680	.4684	.875	.1250	.031	.039	.102	0.250
JUIO-01-08	1/2	.5940	.5934	1.250	.1250	.031	.059	.122	0.394
JUIO-01-10	5/8	.7190	.7184	1.500	.1406	.039	.067	.142	0.433
JUIO-01-12	3/4	.8755	.8747	1.625	.1875	.039	.079	.142	0.492
JUIO-01-16	1	1.1255	1.1247	2.250	.1875	.039	.079	.161	0.630
JUIO-01-20	1 1/4	1.4068	1.4058	2.625	.1875	.039	.079	.161	0.709
JUIO-01-24	1 1/2	1.6568	1.6558	3.000	.2500	.062	.089	.200	0.866
JUIO-01-32	2	2.1881	2.1871	4.000	.2813	.062	.098	.240	1.181

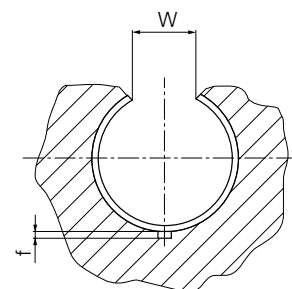

Can be combined with:



OJUI-01



OJUI-03

drylin® R liners | Product Range

Closed design, low clearance – made from iglide® J

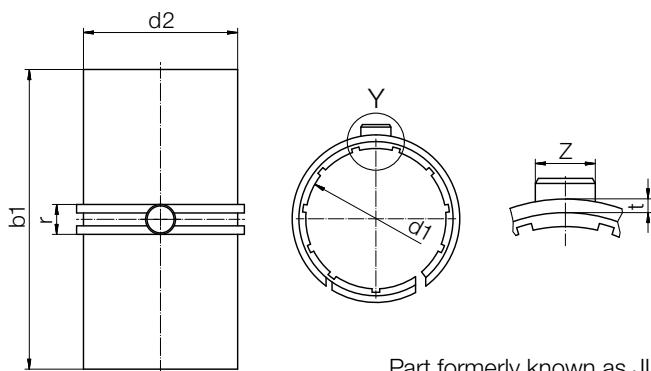

Part formerly known as JUI-20-XX



Order key

Type	Size
J U I -11-10	
iglide® J	
Liner	
Inch	
Low-clearance	
Inner Ø d1	

Best Shaft Material: drylin® AWI hard anodized aluminum, case hardened steel, 300 series stainless, 400 series stainless, hard chrome plated steel

Maximum static psi = 5,076 (35MPa)

Tighter tolerance than JUI-01-XX



™ According to igus® testing method ▶ Page 1210
Please note: Installation instructions ▶ Page 1212



Min. -58°F (-50°C)
Max. +194°F (+90°C)

Dimensions [inch]

Part No.	Nominal Size	Tolerance™	d2	b1	r	t	z
					-0.004 -0.008	-0.004	-0.020
JUI-11-06	3/8	.0008-.0012	0.4684	0.846	.1250	.0311	.0866
JUI-11-08	1/2	.0008-.0012	0.5934	1.220	.1250	.0391	.1024
JUI-11-10	5/8	.0008-.0012	0.7184	1.460	.1406	.0391	.1181
JUI-11-12	3/4	.0008-.0012	0.8747	1.575	.1875	.0391	.1339
JUI-11-16	1	.0008-.0012	1.1247	2.205	.1875	.0391	.1496
JUI-11-20	1 1/4	.0010-.0016	1.4058	2.573	.1875	.0391	.1496
JUI-11-24	1 1/2	.0010-.0016	1.6558	2.953	.2500	.0625	.1811
JUI-11-32	2	.0012-.0020	2.1871	3.937	.2813	.0625	.2280

Installation drawings housing bore for Liner JUI-20

Dimensions [inch]

Part No.	Nominal Size	di	B	r	t	f	z	
		Max.	Min.	*h10	+0.002	+0.004	+0.02	+0.008
JUI-11-06	3/8	.4680	.4684	.875	.1250	.031	.039	.102
JUI-11-08	1/2	.5940	.5934	1.250	.1250	.0391	.059	.122
JUI-11-10	5/8	.7190	.7184	1.500	.1406	.0391	.067	.142
JUI-11-12	3/4	.8755	.8747	1.625	.1875	.0391	.079	.142
JUI-11-16	1	1.1255	1.1247	2.250	.1875	.0391	.079	.161
JUI-11-20	1 1/4	1.4068	1.4058	2.625	.1875	.0391	.079	.161
JUI-11-24	1 1/2	1.6568	1.6558	3.000	.2500	.051	.098	.200
JUI-11-32	2	2.1881	2.1871	4.000	.2813	.051	.098	.240

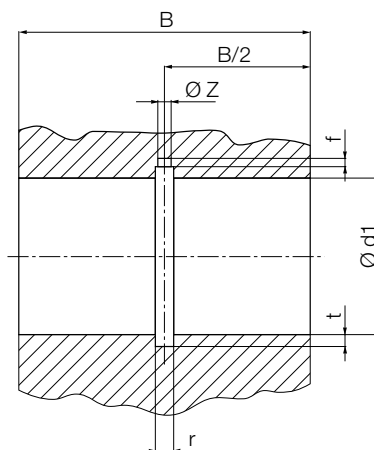

Can be combined with:



RJUI-01/-03



TJUI-01/-03

drylin® R liners | Product range

Open design, low clearance, for supported shafts – made from iglide® J

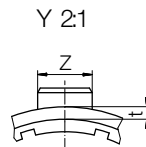
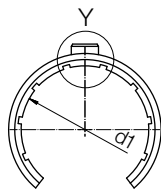
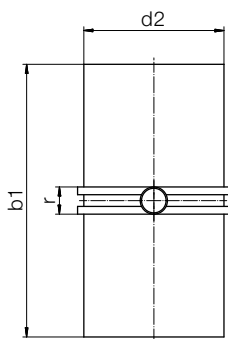

Order key

Type	Size
J U I O - 11 - 10	
iglide® J	
Liner	
Inch	
Open	
Low-clearance	
Inner Ø d1	

Part formerly known as JUIO-20-XX

Best Shaft Material: drylin® AWUI hard anodized aluminum, case hardened steel, 300 series stainless, 400 series stainless, hard chrome plated steel

Maximum static psi = 5,076 (35MPa)



⁷⁸⁾ According to igus® testing method ▶ Page 1210
Please note: Installation instructions ▶ Page 1212



Min. -58°F (-50°C)
Max. +194°F (+90°C)

Dimensions [inch]

Part No.	Nominal Size	Tolerance ⁷⁸⁾	d2	b1	W	r	t	z
						-0.004 -0.008	-0.004	-0.020
JUIO-11-06	3/8	.0008-.0012	0.4684	0.846	0.250	.1250	.0311	.0866
JUIO-11-08	1/2	.0008-.0012	0.5934	1.220	0.394	.1250	.0391	.1024
JUIO-11-10	5/8	.0008-.0012	0.7184	1.460	0.433	.1406	.0391	.1181
JUIO-11-12	3/4	.0008-.0012	0.8747	1.575	0.492	.1875	.0391	.1339
JUIO-11-16	1	.0008-.0012	1.1247	2.205	0.630	.1875	.0391	.1496
JUIO-11-20	1 1/4	.0010-.0016	1.4058	2.573	0.709	.1875	.0391	.1496
JUIO-11-24	1 1/2	.0010-.0016	1.6558	2.953	0.866	.2500	.0625	.1811
JUIO-11-32	2	.0012-.0020	2.1871	4.937	1.181	.2813	.0625	.2280

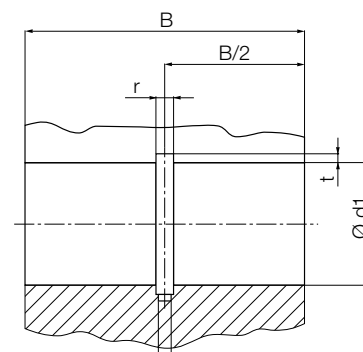

Installation drawings housing bore for Liner JUIO-20

Dimensions [Inch]

Part No.	Shaft Size Ø	di Min.	di Max.	B *h10	r	t	f	z	W
Standard					+0.002	+0.004	+0.02	+0.008	+0.008
JUIO-11-06	3/8	.4680	.4684	.875	.1250	.031	.039	.102	0.250
JUIO-11-08	1/2	.5940	.5934	1.250	.1250	.031	.059	.122	0.394
JUIO-11-10	5/8	.7190	.7184	1.500	.1406	.039	.067	.142	0.433
JUIO-11-12	3/4	.8755	.8747	1.625	.1875	.039	.079	.142	0.492
JUIO-11-16	1	1.1255	1.1247	2.250	.1875	.039	.079	.161	0.630
JUIO-11-20	1 1/4	1.4068	1.4058	2.625	.1875	.039	.079	.161	0.709
JUIO-11-24	1 1/2	1.6568	1.6558	3.000	.2500	.062	.089	.200	0.866
JUIO-11-32	2	2.1881	2.1871	4.000	.2813	.062	.098	.240	1.181

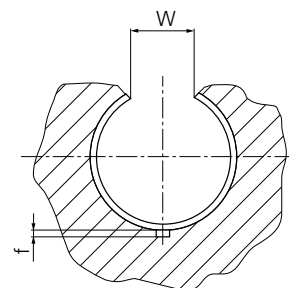

Can be combined with:



OJUI-01



OJUI-03

drylin® R liners | Product Range

Closed design for shafts – made from iglide® J200

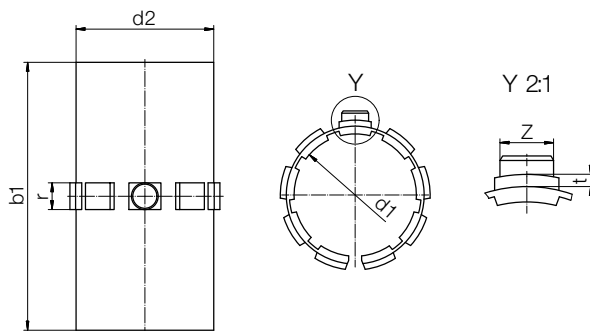

Order key

Type	Size
J200 U I -01-10	
iglide® J200	
Liner	
Inch	
Standard	
Inner Ø d1	

Best Shaft Material: drylin® AWUI hard anodized aluminum

Maximum static psi = 3,336



™ According to igus® testing method ▶ Page 1210
Please note: Installation instructions ▶ Page 1212



Min. -58°F (-50°C)
Max. +194°F (+90°C)

Dimensions [inch]

Part No.	Nominal Size	Tolerance [®]	d2	b1	r	t	z
					-0.004 -0.008	-0.004	-0.020
J200UI-01-06	3/8	.0016-.0024	0.4684	0.846	.1250	.0311	.0866
J200UI-01-08	1/2	.0016-.0024	0.5934	1.220	.1250	.0391	.1024
J200UI-01-10	5/8	.0016-.0024	0.7184	1.460	.1406	.0391	.1181
J200UI-01-12	3/4	.0016-.0024	0.8747	1.575	.1875	.0391	.1339
J200UI-01-16	1	.0016-.0024	1.1247	2.205	.1875	.0391	.1496
J200UI-01-20	1 1/4	.0020-.0032	1.4058	2.573	.1875	.0391	.1496
J200UI-01-24	1 1/2	.0020-.0032	1.6558	2.953	.2500	.0625	.1811

Installation drawings housing bore for Liner J200UI-01

Dimensions [inch]

Part No.	Nominal Size	d1 Max.	d1 Min.	B *h10	r +0.002	t +0.004	f +0.02	z +0.008
J200UI-01-06	3/8	.4680	.4684	.875	.1250	.031	.039	.102
J200UI-01-08	1/2	.5940	.5934	1.250	.1250	.0391	.059	.122
J200UI-01-10	5/8	.7190	.7184	1.500	.1406	.0391	.067	.142
J200UI-01-12	3/4	.8755	.8747	1.625	.1875	.0391	.079	.142
J200UI-01-16	1	1.1255	1.1247	2.250	.1875	.0391	.079	.161
J200UI-01-20	1 1/4	1.4068	1.4058	2.625	.1875	.0391	.079	.161
J200UI-01-24	1 1/2	1.6568	1.6558	3.000	.2500	.051	.098	.200

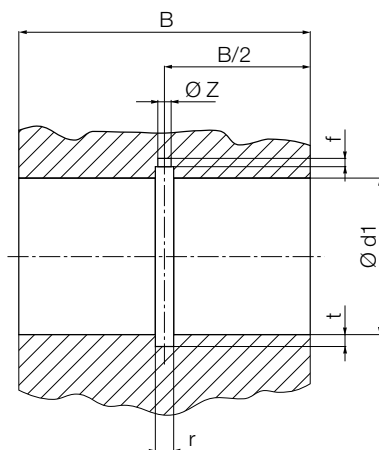

Can be combined with:



RJUI-01/-03



TJUI-01/-03

drylin® R liners | Product range

Open design for supported shafts – made from iglide® J200

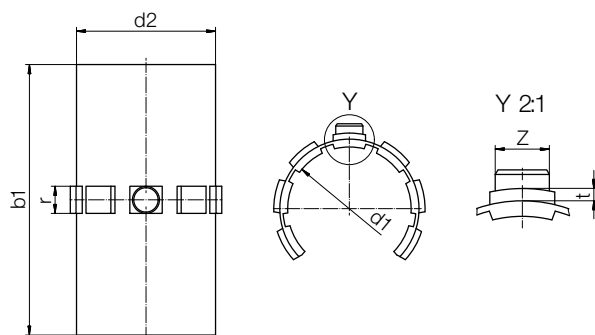

Order key

Type	Size
J200 U I O -01 -10	
iglide® J200	
Liner	
Inch	
Open	
Standard	
Inner Ø d1	

Best Shaft Material: drylin® AWUI hard anodized aluminum

Maximum static psi = 3,336



⁷⁸⁾ According to igus® testing method ▶ Page 1210
Please note: Installation instructions ▶ Page 1212



Min. -58°F (-50°C)
Max. +194°F (+90°C)

Dimensions [inch]

Part No.	Nominal Size	Tolerance ⁷⁸⁾	d2	b1	W	r	t	z
						-0.004 -0.008	-0.004	-0.020
J200UIO-01-06	3/8	.0016-.0024	0.4684	0.846	0.250	.1250	.0311	.0866
J200UIO-01-08	1/2	.0016-.0024	0.5934	1.220	0.394	.1250	.0391	.1024
J200UIO-01-10	5/8	.0016-.0024	0.7184	1.460	0.433	.1406	.0391	.1181
J200UIO-01-12	3/4	.0016-.0024	0.8747	1.575	0.492	.1875	.0391	.1339
J200UIO-01-16	1	.0016-.0024	1.1247	2.205	0.630	.1875	.0391	.1496
J200UIO-01-20	1 1/4	.0020-.0032	1.4058	2.573	0.709	.1875	.0391	.1496
J200UIO-01-24	1 1/2	.0020-.0032	1.6558	2.953	0.866	.2500	.0625	.1811

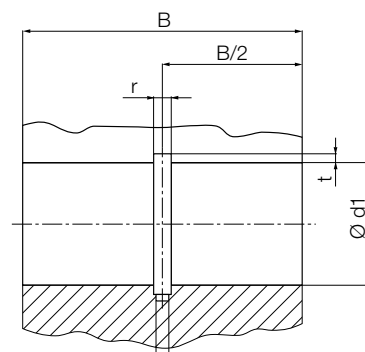

Installation drawings housing bore for Liner J200UIO-01

Dimensions [Inch]

Part No.	Shaft Size Ø	di		B	r	t	f	z	W
		Min.	Max.						
J200UIO-01-06	3/8	.4680	.4684	.875	.1250	.031	.039	.102	0.250
J200UIO-01-08	1/2	.5940	.5934	1.250	.1250	.031	.059	.122	0.394
J200UIO-01-10	5/8	.7190	.7184	1.500	.1406	.039	.067	.142	0.433
J200UIO-01-12	3/4	.8755	.8747	1.625	.1875	.039	.079	.142	0.492
J200UIO-01-16	1	1.1255	1.1247	2.250	.1875	.039	.079	.161	0.630
J200UIO-01-20	1 1/4	1.4068	1.4058	2.625	.1875	.039	.079	.161	0.709
J200UIO-01-24	1 1/2	1.6568	1.6558	3.000	.2500	.062	.089	.200	0.866

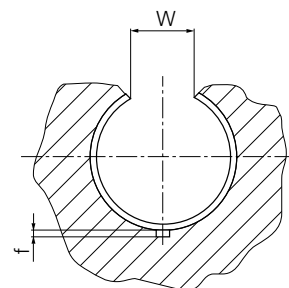

Can be combined with: Can replace liners in these series (most sizes)



OJUI-01



OJUI-03

drylin® R linear | Product Range

Closed design for shafts – made from iglide® E7

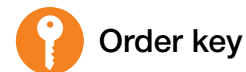
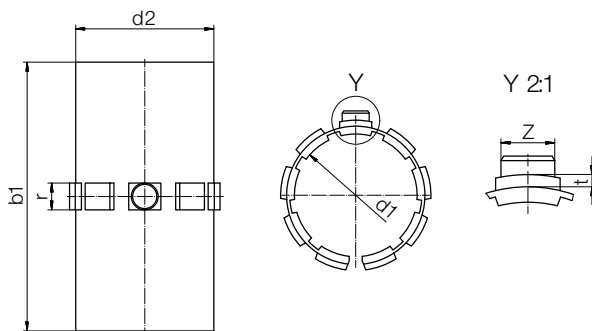

Type	Size
E7 U I -01 -10	
iglide® E7	Liner
Inch	Standard
	Inner Ø d1

Best Shaft Material: case hardened steel, 300 series stainless, 400 series stainless, SWI/SWI2 Case hardened steel, EEWI/EWI Hardened stainless steel as well as 300 series stainless

Maximum static psi = 2,611



™ According to igus® testing method ▶ Page 1210
Please note: Installation instructions ▶ Page 1212



Min. -58°F (-50°C)
Max. +158°F

Dimensions [inch]

Part No.	Nominal Size	Tolerance ⁷⁸	d2	b1	r	t	z
					-0.004 -0.008	-0.004	-0.020
E7UI-01-08	1/2	.0016 - .0024	0.5934	1.220	.1250	.0391	.1024
E7UI-01-10	5/8	.0016 - .0024	0.7184	1.460	.1406	.0391	.1181
E7UI-01-12	3/4	.0016 - .0024	0.8747	1.575	.1875	.0391	.1339
E7UI-01-16	1	.0016 - .0024	1.1247	2.205	.1875	.0391	.1496
E7UI-01-20	1 1/4	.0020 - .0032	1.4058	2.573	.1875	.0391	.1496
E7UI-01-24	1 1/2	.0020 - .0032	1.6558	2.953	.2500	.0625	.1811
E7UI-01-32	2	.0024 - .0040	2.1871	3.937	.2813	.0625	.2280

Installation drawings housing bore for Liner JUI-01

Dimensions [inch]

Part No.	Nominal Size	di		B	r	t	f	z
		Max.	Min.					
E7UI-01-08	1/2	.5940	.5934	1.250	.1250	.0391	.059	.122
E7UI-01-10	5/8	.7190	.7184	1.500	.1406	.0391	.067	.142
E7UI-01-12	3/4	.8755	.8747	1.625	.1875	.0391	.079	.142
E7UI-01-16	1	1.1255	1.1247	2.250	.1875	.0391	.079	.161
E7UI-01-20	1 1/4	1.4068	1.4058	2.625	.1875	.0391	.079	.161
E7UI-01-24	1 1/2	1.6568	1.6558	3.000	.2500	.051	.098	.200
E7UI-01-32	2	2.1881	2.1871	4.000	.2813	.051	.098	.240

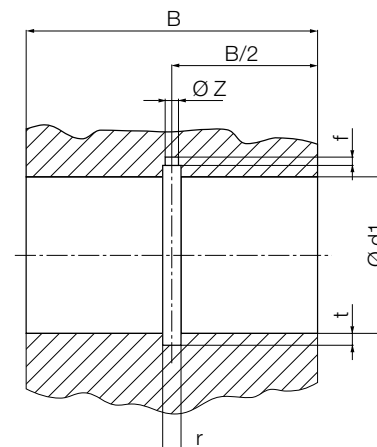

Can be combined with: Can replace liners in these series (most sizes)



RJUI-01/-03



TJUI-01/-03

drylin® R linear | Product Range

Open design for supported shafts – made from iglide® E7

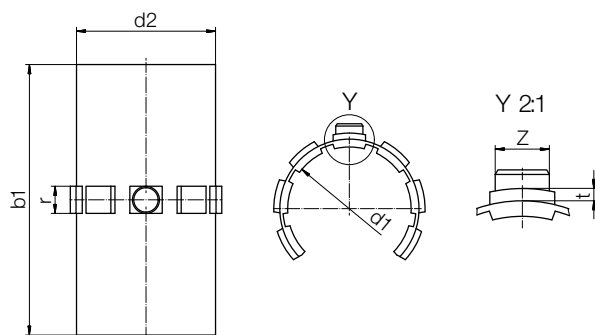

Order key

Type	Size
E7 U I O -01 -10	
iglide® E7	
Liner	
Inch	
Open	
Standard	
Inner Ø d1	

Best Shaft Material: case hardened steel, 300 series stainless, 400 series stainless, SWUI Case hardened steel, EWUI Hardened stainless steel as well as chrome plated steel

Maximum static psi = 2,611



⁷⁸⁾ According to igus® testing method ▶ Page 1210
Please note: Installation instructions ▶ Page 1212



Min. -58°F (-50°C)
Max. +158°F

Dimensions [inch]

Part No.	Nominal Size	Tolerance ⁷⁸⁾	d2	b1	W	r	t	z
						-0.004 -0.008	-0.004	-0.020
E7UIO-01-08	1/2	.0016-.0024	0.5934	1.220	0.394	.1250	.0391	.1024
E7UIO-01-10	5/8	.0016-.0024	0.7184	1.460	0.433	.1406	.0391	.1181
E7UIO-01-12	3/4	.0016-.0024	0.8747	1.575	0.492	.1875	.0391	.1339
E7UIO-01-16	1	.0016-.0024	1.1247	2.205	0.630	.1875	.0391	.1496
E7UIO-01-20	1 1/4	.0020-.0032	1.4058	2.573	0.709	.1875	.0391	.1496
E7UIO-01-24	1 1/2	.0020-.0032	1.6558	2.953	0.866	.2500	.0625	.1811
E7UIO-01-32	2	.0024-.0040	2.1871	4.937	1.181	.2813	.0625	.2280

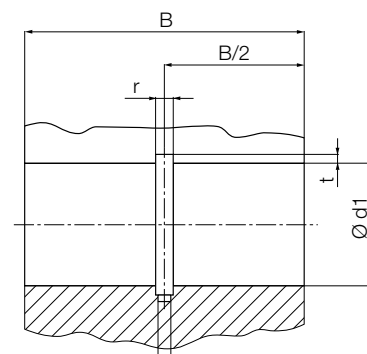

Installation drawings housing bore for Liner JUIO-01

Dimensions [Inch]

Part No.	Shaft Size Ø	di Min.	di Max.	B *h10	r	t	f	z	W
Standard					+0.002	+0.004	+0.02	+0.008	+0.008
E7UIO-01-08	1/2	.5940	.5934	1.250	.1250	.031	.059	.122	0.394
E7UIO-01-10	5/8	.7190	.7184	1.500	.1406	.039	.067	.142	0.433
E7UIO-01-12	3/4	.8755	.8747	1.625	.1875	.039	.079	.142	0.492
E7UIO-01-16	1	1.1255	1.1247	2.250	.1875	.039	.079	.161	0.630
E7UIO-01-20	1 1/4	1.4068	1.4058	2.625	.1875	.039	.079	.161	0.709
E7UIO-01-24	1 1/2	1.6568	1.6558	3.000	.2500	.062	.089	.200	0.866
E7UIO-01-32	2	2.1881	2.1871	4.000	.2813	.062	.098	.240	1.181

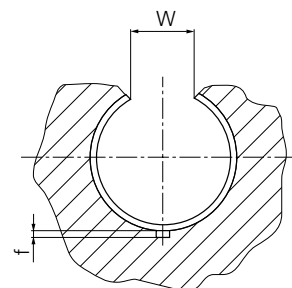

Can be combined with: Can replace liners in these series (most sizes)



OJUI-01



OJUI-03

drylin® R linear | Product Range

Closed design for shafts – made from iglide® X

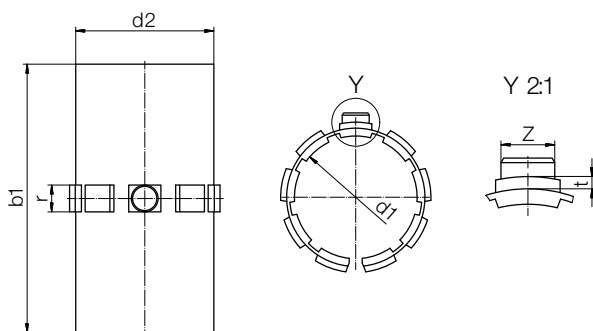

Order key

Type		Size		
X U I -01 -10				
iglide® X	Liner	Inch	Standard	Inner Ø d1

Material: iglide® X

Temp. range: -148°F to +482°F in steel housing, up to 356°F in aluminum adapter

Best Shaft Material: Hardened stainless and hard chrome plated steel. EEWI/EWI Hardened stainless steel, as well as chrome-plated steel

Maximum static psi = 21,760



™ According to igus® testing method ▶ Page 1210
Please note: Installation instructions ▶ Page 1212



Min. -148°F
Max. +482°F

Note: this liner is made of two pieces used together as one part number

Dimensions [inch]

Part No.	Nominal Size	Tolerance*	d2	b1	r	t	z
					-0.004 -0.008	-0.004	-0.020
XUI-01-08	1/2	.0016-.0024	0.5934	1.220	.1250	.0391	.1024
XUI-01-12	3/4	.0016-.0024	0.8747	1.545	.1875	.0391	.1339
XUI-01-16	1	.0016-.0024	1.1247	2.205	.1875	.0391	.1496
XUI-01-20	1 1/4	.0020-.0032	1.4058	2.573	.1875	.0391	.1496
XUI-01-24	1 1/2	.0020-.0032	1.6558	2.953	.2500	.0625	.1811

Installation drawings housing bore for Liner XUI-01

Dimensions [inch]

Part No.	Nominal Size	di	B	r	t	f	z
		Max.	*h10	+0.002	+0.004	+0.02	+0.008
XUI-01-08	1/2	.5940	.5934	1.250	.1250	.0391	.122
XUI-01-12	3/4	.8755	.8747	1.625	.1875	.0391	.142
XUI-01-16	1	1.1255	1.1247	2.250	.1875	.0391	.161
XUI-01-20	1 1/4	1.4068	1.4058	2.625	.1875	.0391	.161
XUI-01-24	1 1/2	1.6568	1.6558	3.000	.2500	.051	.200

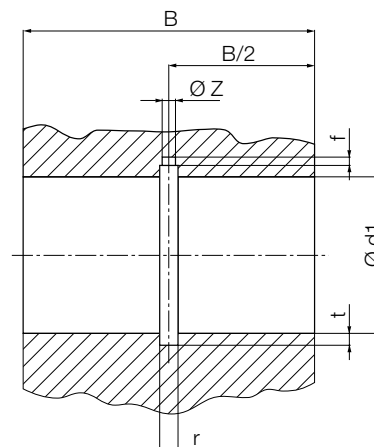

Can be combined with: Can replace liners in these series (most sizes)



RJUI-01/-03



TJUI-01/-03

drylin® R linear | Product Range

Open design for shafts – made from iglide® X



Type	Size
X U I O -01 -10	
iglide® X	
Liner	
Inch	
Open	
Standard	
Inner Ø d1	

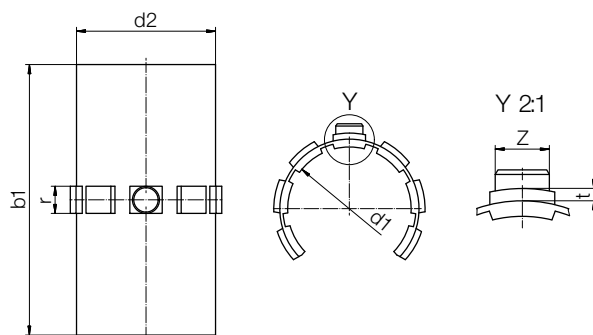

Material: iglide® X

Temp. range: -148°F to +482°F in steel housing, up to 356°F in aluminum adapter

Best Shaft Material: Hardened stainless and hard chrome plated steel. EWUI Hardened stainless steel, as well as chrome-plated steel

Maximum static psi = 21,760



⁷⁸⁾ According to igus® testing method ► Page 1210
Please note: Installation instructions ► Page 1212



Min. -148°F
Max. +482°F

Note: this liner is made of two pieces used together as one part number

Dimensions [inch]

Part No.	Nominal Size	Tolerance ^{a)}	d2	b1	W	r	t	z
						-0.004 -0.008	-0.004	-0.020
XUIO-01-08	1/2	.0016-.0024	0.5934	1.220	0.394	.1250	.0391	.1024
XUIO-01-12	3/4	.0016-.0024	0.8747	1.575	0.492	.1875	.0391	.1339
XUIO-01-16	1	.0016-.0024	1.1247	2.205	0.630	.1875	.0391	.1496
XUIO-01-20	1 1/4	.0020-.0032	1.4058	2.573	0.709	.1875	.0391	.1496
XUIO-01-24	1 1/2	.0020-.0032	1.6558	2.953	0.866	.2500	.0625	.1811

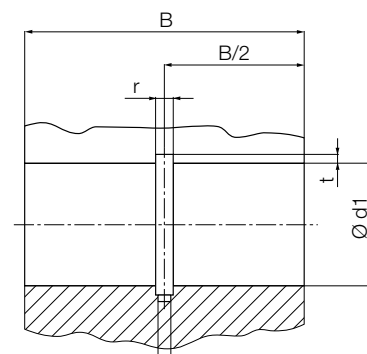

Installation drawings housing bore for XUIO-01 | dimensions [inch]

Part No.	Shaft Size Ø	di		B	r	t	f	z	W
		Min.	Max.						
Standard				*h10	+0.002	+0.004	+0.02	+0.008	+0.008
XUIO-01-08	1/2	.5940	.5934	1.250	.1250	.031	.059	.122	0.394
XUIO-01-12	3/4	.8755	.8747	1.625	.1875	.039	.079	.142	0.492
XUIO-01-16	1	1.1255	1.1247	2.250	.1875	.039	.079	.161	0.630
XUIO-01-20	1 1/4	1.4068	1.4058	2.625	.1875	.039	.079	.161	0.709
XUIO-01-24	1 1/2	1.6568	1.6558	3.000	.2500	.062	.089	.200	0.866

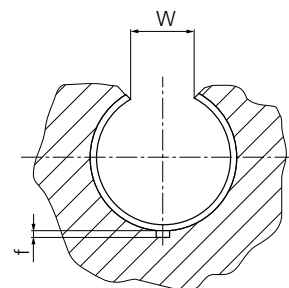

Can be combined with: Can replace liners in these series (most sizes)



OJUI-01/03

drylin® R solid plastic bearings | Product Range

Standard design made from iglide® J

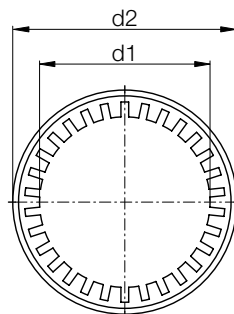
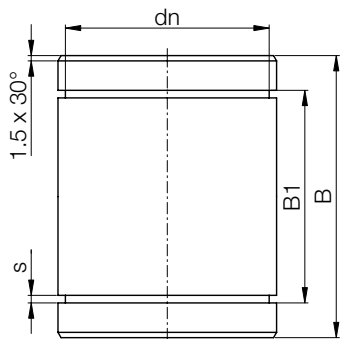

Order key

Type Size

R J I - 01 - 12

Closed	iglide® J	Inch	Standard	Inner Ø d1
--------	-----------	------	----------	------------

- Assembly by press-fitting using arbor press
Secured by snap ring
- NOTE: Parts are oversized prior to pressfit, and must be measured in a housing for accurate ID tolerance



⁷⁸⁾ According to igus® testing method ► Page 1210

⁸²⁾ Design standards ► Page 1209

⁸³⁾ Applies to room temperature: press-fit decreases with time depending on the temperature

Please note: Installation instructions ► Page 1212



Min. -68°F
Max. +140°F

Technical Data

Part No.	Shaft Ø	d1-Tolerance ⁷⁸⁾ after pressfit in housing	Fmax. dyn. ⁸²⁾ P = 2.5 MPa [N]	Fmax. stat. ⁸²⁾ P = 17.5 MPa [N]	Housing bore Recommendations		Weight [g]	Pressfit force ⁸³⁾ [N]
					Min	Max		
RJI-01-06	3/8	+0.0010 +0.0024	265	1.855	0.6250	0.6257	3	400
RJI-01-08	1/2	+0.0013 +0.0030	505	3.535	0.8750	0.8758	8.8	700
RJI-01-10	5/8	+0.0013 +0.0030	755	5.285	1.1250	1.1258	17.4	1,300
RJI-01-12	3/4	+0.0016 +0.0036	982	6.877	1.2500	1.2510	22.2	1,100
RJI-01-16	1	+0.0016 +0.0036	1.815	12.705	1.5620	1.5630	42.5	1,500
RJI-01-20	1 1/4	+0.0020 +0.0044	2.645	18.515	2.0000	2.0010	81.1	3,500
RJI-01-24	1 1/2	+0.0020 +0.0044	3.630	25.410	2.3750	2.3760	127.1	4,500
RJI-01-32	2	+0.0024 +0.0053	6.452	45.167	3.0000	3.0010	249	4,200

Dimensions [inch]

Part No.	d1	d2	B	B1	s	dn
RJI-01-06	3/8	0.625	0.875	0.689	0.0410	0.587
RJI-01-08	1/2	0.875	1.25	1.0125	0.0480	0.82
RJI-01-10	5/8	1.125	1.50	1.0950	0.0580	1.0600
RJI-01-12	3/4	1.25	1.625	1.25	0.0580	1.177
RJI-01-16	1	1.5625	2.25	1.864	0.0700	1.471
RJI-01-20	1 1/4	2.00	2.625	1.984	0.0700	1.889
RJI-01-24	1 1/2	2.375	3.00	2.39	0.0890	2.241
RJI-01-32	2	3.00	4.00	3.163	0.1050	2.839

drylin® R solid plastic bearings | Product Range

Standard design, low-clearance / precision, made from iglide® J

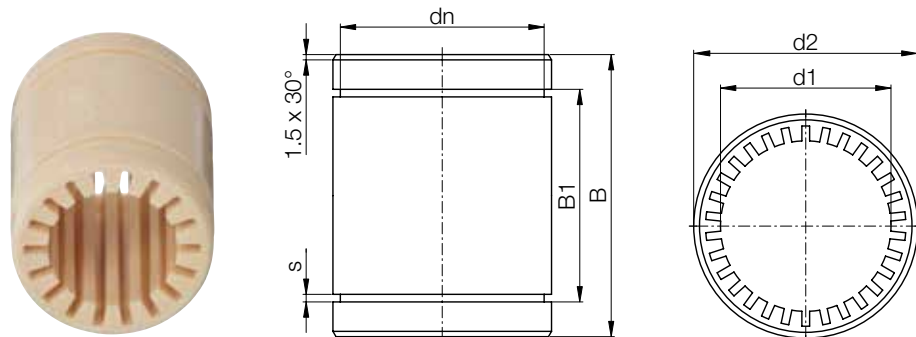

- Easy assembly by light press-fit
- Reduced bearing clearance
- Secured by snap ring

 Order key

Type				Size	
R	J	I	P	-01	-10
Closed	iglide® J	Inch	Low clearance	Standard	Inner Ø d1

⁷⁸⁾ According to igus® testing method ► Page 1210

⁸²⁾ Design standards ► Page 1209

Please note: Installation instructions ► Page 1212



Min. -68°F

Max. +140°F

Technical Data

Part No.	Shaft Ø	d1-Tolerance ⁷⁸⁾	Fmax. dyn. ⁸²⁾ P = 2.5 MPa [N]	Fmax. stat. ⁸²⁾ P = 2.5 MPa [N]	Housing bore Recommendations		Weight [g]
					Min	Max	
RJIP-01-04	1/4	+ 0.0010 +0.0027	180	1.267	0.5000	0.5007	2
RJIP-01-06	3/8	+ 0.0010 +0.0027	265	1.855	0.6250	0.6257	2
RJIP-01-08	1/2	+ 0.0012 +0.0030	505	3.535	0.8750	0.8758	4
RJIP-01-10	5/8	+ 0.0000 +0.0015	755	5.285	1.1250	1.1258	7
RJIP-01-12	3/4	+ 0.0015 +0.0036	982	6.877	1.2500	1.2510	9
RJIP-01-16	1	+ 0.0000 +0.0020	1.815	12.705	1.5620	1.5630	13
RJIP-01-20	1 1/4	+ 0.0000 +0.0024	2.645	18.515	2.0000	2.0010	24

Dimensions [inch]

Part No.	d1	d2	B	B1	s	dn
RJIP-01-04	1/4	0.4999	0.74803	0.5188	0.0409	0.4669
RJIP-01-06	3/8	0.625	0.875	0.689	0.0410	0.587
RJIP-01-08	1/2	0.875	1.25	1.0125	0.0480	0.82
RJIP-01-10	5/8	1.125	1.50	1.0950	0.0580	1.0600
RJIP-01-12	3/4	1.25	1.625	1.25	0.0580	1.177
RJIP-01-16	1	1.5625	2.25	1.864	0.0700	1.471
RJIP-01-20	1 1/4	2.00	2.625	1.984	0.0700	1.889

drylin® R linear | Product Range

Closed, anodized aluminum adapter - iglide® J liner

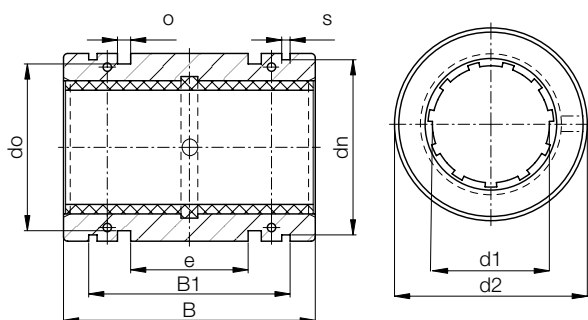

Order key

Type					Size
R J U I - 01 - 10					
Closed	iglide® J	Liner	Inch	Standard	Inner Ø d1

- Suitable shafting for iglide® J: drylin® AWI aluminum, SWI/SWI2 hardened steel, 300 series stainless Best shafting for X: hard-chrome and hard-stainless steel
- Secured by snap ring
- Dimensionally interchangeable with linear ball bearings



⁷⁸⁾ According to igus® testing method ▶ Page 1210

⁸²⁾ Design standards ▶ Page 1209

Please note: Installation instructions ▶ Page 1212

Dimensions (inch)

Part No.	Nominal Size	Tolerance ⁷⁸⁾	d2 ISO h7	B ISO h10	B1 ISO H10	s	dn	e	o +.004	do
RJZI-01-04*	1/4	.0016 - .0032	.5000	.7500	.518	.0410	.4670	.125	.0800	.3990
RJUI-01-06	3/8	.0016 - .0032	.6250	.8700	.644	.0410	.5870	.243	.0610	.5660
RJUI-01-08	1/2	.0016 - .0032	.8750	1.2500	.979	.0520	.8200	.281	.1250	.7120
RJUI-01-10	5/8	.0016 - .0032	1.1250	1.5000	1.124	.0620	1.0600	.312	.1250	.9620
RJUI-01-12	3/4	.0016 - .0032	1.2500	1.6200	1.186	.0620	1.1770	.312	.1250	1.0870
RJUI-01-16	1	.0016 - .0032	1.5625	2.2500	1.773	.0740	1.4710	.500	.1250	1.3990
RJUI-01-20	1-1/4	.0020 - .0041	2.0000	2.6200	2.023	.0740	1.8890	.625	.1250	1.8370
RJUI-01-24	1-1/2	.0020 - .0041	2.3750	3.0000	2.440	.0950	2.2410	.750	.1620	2.1520
RJUI-01-32	2	.0024 - .0051	3.0000	4.0000	3.222	.1110	2.8390	1.000	.1890	2.7750

*Size -04 available with press-fit bushing only. J material standard

Housing Bore Recommendations

Nominal ID Size	Min.	Max.
1/4	0.5000	0.5007
3/8	0.6250	0.6257
1/2	0.8750	0.8758
5/8	1.1250	1.1258
3/4	1.2500	1.2510
1	1.5625	1.5635
1-1/4	2.0000	2.0010
1-1/2	2.3750	2.3760
2	3.0000	3.0010

Technical Data

Part No.	F max, dynamic ⁸²⁾ p = 725 psi (lbs)	F max, static ⁸²⁾ p = 5075 psi (lbs)
RJZI-01-04*	135	946
RJUI-01-06	118	828
RJUI-01-08	225	1575
RJUI-01-10	338	2365
RJUI-01-12	439	3077
RJUI-01-16	811	5678
RJUI-01-20	1184	8287
RJUI-01-24	1622	11358
RJUI-01-32	2885	20198

Available with drylin® liners (most sizes)



E7



X

- X liner optional for chemicals/high temps up to +482°F (+250°C) for steel housing, up to +356°F (+180°C) for aluminum

Optional



J200



A180

drylin® R linear | Product Range

Closed, anodized aluminum adapter, low clearance - iglide® J liner

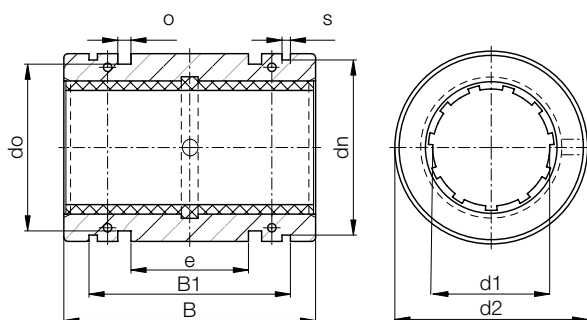

Order key

Type	Size
R J U I - 11 - 10	
Closed	
iglide® J	
Liner	
Inch	
Low-clearance	
Inner Ø d1	

Part formerly known as
RJUI-21-XX

- Max. bearing clearance reduced by 50%
- Suitable shafting for iglide® J: drylin® AWI aluminum, SWI/SWI2 hardened steel, 300 series stainless Best shafting for X: hard-chrome and hard-stainless steel
- Secured by snap ring
- Dimensionally interchangeable with linear ball bearings

⁷⁸ According to igus® testing method ► Page 1210⁸² Design standards ► Page 1209

Please note: Installation instructions ► Page 1212

Dimensions (inch)

Part No.	Nominal Size	Tolerance ⁷⁸	d2 ISO h7	B ISO h10	B1 ISO H10	s	dn	e	o +.004	do
RJUI-11-06	3/8	.0008 - .0016	.6250	.8700	.644	.0410	.5870	.243	.0610	.5660
RJUI-11-08	1/2	.0008 - .0016	.8750	1.2500	.979	.0520	.8200	.281	.1250	.7120
RJUI-11-10	5/8	.0008 - .0016	1.1250	1.5000	1.124	.0620	1.0600	.312	.1250	.9620
RJUI-11-12	3/4	.0008 - .0016	1.2500	1.6200	1.186	.0620	1.1770	.312	.1250	1.0870
RJUI-11-16	1	.0008 - .0016	1.5625	2.2500	1.773	.0740	1.4710	.500	.1250	1.3990
RJUI-11-20	1-1/4	.0010 - .0021	2.0000	2.6200	2.023	.0740	1.8890	.625	.1250	1.8370
RJUI-11-24	1-1/2	.0010 - .0021	2.3750	3.0000	2.440	.0950	2.2410	.750	.1620	2.1520
RJUI-11-32	2	.0012 - .0026	3.0000	4.0000	3.222	.1110	2.8390	1.000	.1890	2.7750

Housing Bore Recommendations

Nominal ID Size	Min.	Max.
3/8	0.6250	0.6257
1/2	0.8750	0.8758
5/8	1.1250	1.1258
3/4	1.2500	1.2510
1	1.5625	1.5635
1-1/4	2.0000	2.0010
1-1/2	2.3750	2.3760
2	3.0000	3.0010

Technical Data

Part No.	F max, dynamic ⁸² p = 725 psi (lbs)	F max, static ⁸² p = 5075 psi (lbs)
RJUI-11-06	118	828
RJUI-11-08	225	1575
RJUI-11-10	338	2365
RJUI-11-12	439	3077
RJUI-11-16	811	5678
RJUI-11-20	1184	8287
RJUI-11-24	1622	11358
RJUI-11-32	2885	20198

drylin® R linear | Product Range

Closed, anodized aluminum adapter, Self-aligning - iglide® J liner

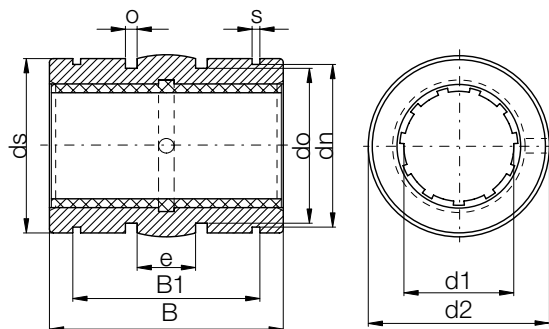

Order key

Type	Size
R J U I -03-10	
Closed	
iglide® J	
Liner	
Inch	
Self-aligning	
Inner Ø d1	

- Suitable shafting for iglide® J: drylin® AWI aluminum, SWI/SWI2 hardened steel, 300 series stainless Best shafting for X: hard-chrome and hard-stainless steel
- Secured by snap ring
- Dimensionally interchangeable with linear ball bearings



⁷⁸⁾ According to igus® testing method ► Page 1210

⁸²⁾ Design standards ► Page 1209

Please note: Installation instructions ► Page 1212

Dimensions (inch)

Part No.	Nominal Size	Tolerance ⁷⁸⁾	d2 ISO h8	B ISO h10	B1 ISO H10	s	ds	dn ISO h10	do	o -0.004	e
RJZI-03-04*	1/4	.0016-.0032	.4921	.7460	.5270	.0410	.4803	.4660	.3990	.0800	.1250
RJUI-03-06	3/8	.0016-.0032	.6173	.8713	.6520	.0410	.6055	.5870	.5240	.0610	.2430
RJUI-03-08	1/2	.0016-.0032	.8673	1.2461	.9870	.0520	.8556	.8200	.7120	.1250	.2815
RJUI-03-10	5/8	.0016-.0032	1.1173	1.4961	1.1360	.0620	1.1055	1.0600	.9620	.1250	.3125
RJUI-03-12	3/4	.0016-.0032	1.2421	1.6173	1.1980	.0620	1.2300	1.1770	1.0870	.1250	.3125
RJUI-03-16	1	.0016-.0032	1.5547	2.2421	1.7890	.0740	1.5271	1.4710	1.3990	.1250	.5000
RJUI-03-20	1-1/4	.0020-.0041	1.9881	2.6173	2.0390	.0740	1.9606	1.8890	1.8370	.1250	.6250
RJUI-03-24	1-1/2	.0020-.0041	2.3634	2.9921	2.4630	.0950	2.3358	2.2410	2.1520	.1620	.7500
RJUI-03-32	2	.0024-.0051	2.9881	3.9921	3.2490	.1110	2.9606	2.8390	2.7750	.1890	1.0000

*Size -04 available with press-fit bushing only. J material standard

Housing Bore Recommendations

Nominal ID Size	Min.	Max.
1/4	0.5000	0.5007
3/8	0.6250	0.6257
1/2	0.8750	0.8758
5/8	1.1250	1.1258
3/4	1.2500	1.2510
1	1.5625	1.5635
1-1/4	2.0000	2.0010
1-1/2	2.3750	2.3760
2	3.0000	3.0010

Technical Data

Part No.	F max, dynamic ⁸²⁾ p = 725 psi (lbs)	F max, static ⁸²⁾ p = 5075 psi (lbs)
RJZI-03-04*	135	946
RJUI-03-06	118	828
RJUI-03-08	225	1575
RJUI-03-10	338	2365
RJUI-03-12	439	3077
RJUI-03-16	811	5678
RJUI-03-20	1184	8287
RJUI-03-24	1622	11358
RJUI-03-32	2885	20198

Available with drylin® liners (most sizes)



J200



E7



X

- X liner optional for chemicals/high temps up to +482°F (+250°C) for steel housing, up to +356°F (+180°C) for aluminum

drylin® R linear | Product Range

Closed, anodized aluminum adapter - iglide® J200 liner

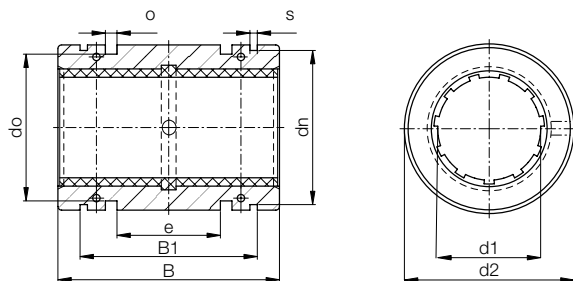

Order key

Type	Size
R J200 U I -01 -10	
Closed	Inner Ø d1
iglide® J200	
Liner	
Inch	
Standard	

- Suitable shafting: AWI Hard anodized aluminum shafting
- Secured by snap ring
- Dimensionally interchangeable with linear ball bearings



⁷⁸⁾ According to igus® testing method ▶ Page 1210

⁸²⁾ Design standards ▶ Page 1209

Please note: Installation instructions ▶ Page 1212

Dimensions (inch)

Part No.	Nominal Size	Tolerance ⁷⁸⁾	d2 ISO h7	B ISO h10	B1 ISO H10	s	dn	e	o +.004	do
RJ200UI-01-06	3/8	.0016 - .0032	.6250	.8700	.644	.0410	.5870	.243	.0610	.5660
RJ200UI-01-08	1/2	.0016 - .0032	.8750	1.2500	.979	.0520	.8200	.281	.1250	.7120
RJ200UI-01-10	5/8	.0016 - .0032	1.1250	1.5000	1.124	.0620	1.0600	.312	.1250	.9620
RJ200UI-01-12	3/4	.0016 - .0032	1.2500	1.6200	1.186	.0620	1.1770	.312	.1250	1.0870
RJ200UI-01-16	1	.0016 - .0032	1.5625	2.2500	1.773	.0740	1.4710	.500	.1250	1.3990
RJ200UI-01-20	1-1/4	.0020 - .0041	2.0000	2.6200	2.023	.0740	1.8890	.625	.1250	1.8370
RJ200UI-01-24	1-1/2	.0020 - .0041	2.3750	3.0000	2.440	.0950	2.2410	.750	.1620	2.1520

Housing Bore Recommendations

Nominal ID Size	Min.	Max.
3/8	0.6250	0.6257
1/2	0.8750	0.8758
5/8	1.1250	1.1258
3/4	1.2500	1.2510
1	1.5625	1.5635
1-1/4	2.0000	2.0010
1-1/2	2.3750	2.3760

Technical Data

Part No.	F max, dynamic ⁸²⁾ p = 725 psi (lbs)	F max, static ⁸²⁾ p = 3336 psi (lbs)
RJ200UI-01-06	118	546
RJ200UI-01-08	225	1039
RJ200UI-01-10	338	1560
RJ200UI-01-12	439	2030
RJ200UI-01-16	811	3747
RJ200UI-01-20	1184	5469
RJ200UI-01-24	1622	7496

Available with drylin® liners (most sizes)



J



E7



X

- X liner optional for chemicals/high temps up to +482°F (+250°C) for steel housing, up to +356°F (+180°C) for aluminum

drylin® R linear | Product Range

Closed, anodized aluminum adapter, Self-aligning - iglide® J200 liner
For aluminum shafting

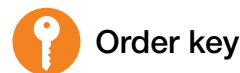
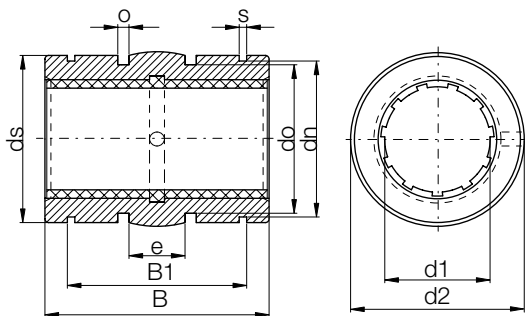

Type					Size
R J200 U I -03-10					
Closed	iglide® J200	Liner	Inch	Self-aligning	Inner Ø d1

- Suitable shafting: AWI Hard anodized aluminum shafting
- Secured by snap ring
- Dimensionally interchangeable with linear ball bearings



⁷⁸⁾ According to igus® testing method ▶ Page 1210
⁸²⁾ Design standards ▶ Page 1209
Please note: Installation instructions ▶ Page 1212

Dimensions (inch)

Part No.	Nominal	Tolerance ⁷⁸⁾	d2	B	B1	s	ds	dn	do	o	e
	Size		ISO h8	ISO h10	ISO H10			ISO h10	-0.004		
RJ200UI-03-06	3/8	.0016-.0032	.6173	.8713	.6520	.0410	.6055	.5870	.5240	.0610	.2430
RJ200UI-03-08	1/2	.0016-.0032	.8673	1.2461	.9870	.0520	.8556	.8200	.7120	.1250	.2815
RJ200UI-03-10	5/8	.0016-.0032	1.1173	1.4961	1.1360	.0620	1.1055	1.0600	.9620	.1250	.3125
RJ200UI-03-12	3/4	.0016-.0032	1.2421	1.6173	1.1980	.0620	1.2300	1.1770	1.0870	.1250	.3125
RJ200UI-03-16	1	.0016-.0032	1.5547	2.2421	1.7890	.0740	1.5271	1.4710	1.3990	.1250	.5000
RJ200UI-03-20	1-1/4	.0020-.0041	1.9881	2.6173	2.0390	.0740	1.9606	1.8890	1.8370	.1250	.6250
RJ200UI-03-24	1-1/2	.0020-.0041	2.3634	2.9921	2.4630	.0950	2.3358	2.2410	2.1520	.1620	.7500

Housing Bore Recommendations

Nominal ID Size	Min. Max.	
	3/8	0.6250
1/2	0.8750	0.8758
5/8	1.1250	1.1258
3/4	1.2500	1.2510
1	1.5625	1.5635
1-1/4	2.0000	2.0010
1-1/2	2.3750	2.3760

Technical Data

Part No.	F max, dynamic ⁸²⁾	F max, static ⁸²⁾
	p = 725 psi (lbs)	p = 3336 psi (lbs)
RJ200UI-03-06	118	546
RJ200UI-03-08	225	1039
RJ200UI-03-10	338	1560
RJ200UI-03-12	439	2030
RJ200UI-03-16	811	3747
RJ200UI-03-20	1184	5469
RJ200UI-03-24	1622	7496

Available with drylin® liners (most sizes)



J



E7



X

- X liner optional for chemicals/high temps up to +482°F (+250°C) for steel housing, up to +356°F (+180°C) for aluminum

drylin® R linear | Product Range

Closed, anodized aluminum adapter - iglide® E7 liner
For steel, hard chromed steel, and stainless steel shafting

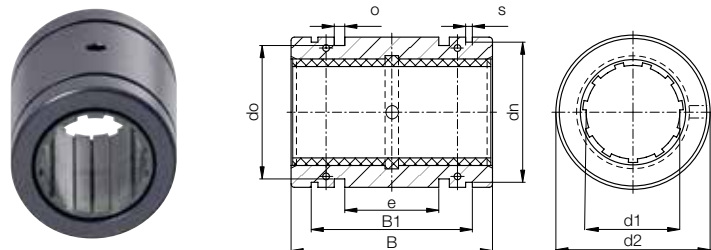

Type					Size	
R	E7	U	I	-01	-10	
Closed	iglide® E7	Liner	Inch	Standard	Diameter	

- Suitable shafting: SWI case-hardened, 300 series stainless, hard-chrome and EWI/EEWI hard-stainless steel
- Secured by snap ring
- Dimensionally interchangeable with linear ball bearings



⁷⁸⁾ According to igus® testing method ▶ Page 1210
⁸²⁾ Design standards ▶ Page 1209
Please note: Installation instructions ▶ Page 1212

Dimensions (inch)

Part No.	Nominal Size	Tolerance ⁷⁸⁾	d2 ISO h7	B ISO h10	B1 ISO H10	s	dn	e	o +.004	do
RE7UI-01-08	1/2	.0016 - .0032	.8750	1.2500	.979	.0520	.8200	.281	.1250	.7120
RE7UI-01-10	5/8	.0016 - .0032	1.1250	1.5000	1.124	.0620	1.0600	.312	.1250	.9620
RE7UI-01-12	3/4	.0016 - .0032	1.2500	1.6200	1.186	.0620	1.1770	.312	.1250	1.0870
RE7UI-01-16	1	.0016 - .0032	1.5625	2.2500	1.773	.0740	1.4710	.500	.1250	1.3990
RE7UI-01-20	1-1/4	.0020 - .0041	2.0000	2.6200	2.023	.0740	1.8890	.625	.1250	1.8370
RE7UI-01-24	1-1/2	.0020 - .0041	2.3750	3.0000	2.440	.0950	2.2410	.750	.1620	2.1520
RE7UI-01-32	2	.0024 - .0051	3.0000	4.0000	3.222	.1110	2.8390	1.000	.1890	2.7750

Housing Bore Recommendations

Nominal ID Size	Min.	Max.
1/2	0.8750	0.8758
5/8	1.1250	1.1258
3/4	1.2500	1.2510
1	1.5625	1.5635
1-1/4	2.0000	2.0010
1-1/2	2.3750	2.3760
2	3.0000	3.0010

Technical Data

Part No.	F max, dynamic ⁸²⁾ p = 362 psi (lbs)	F max, static ⁸²⁾ p = 2611 psi (lbs)
RE7UI-01-08	113	788
RE7UI-01-10	169	1183
RE7UI-01-12	220	1538
RE7UI-01-16	406	2839
RE7UI-01-20	596	4143
RE7UI-01-24	811	5679
RE7UI-01-32	1443	10099

Available with drylin® liners (most sizes)



J



J200



X

- X liner optional for chemicals/high temps up to +482°F (+250°C) for steel housing, up to +356°F (+180°C) for aluminum

drylin® R linear | Product Range

Closed, aluminum adapter - Self-aligning - iglide® E7 liner
For steel, hard chromed steel, and stainless steel



Order key

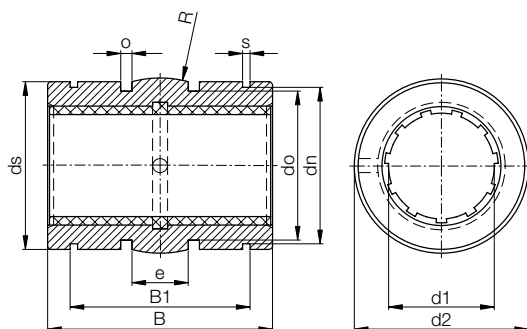

Type					Size
R E7 U I -03-10					
Closed	iglide® E7	Liner	Inch	Self-aligning	Diameter

- Suitable shafting: SWI case-hardened, 300 series stainless, hard-chrome and EWI/EEWI hard-stainless steel
- Secured by snap ring
- Dimensionally interchangeable with linear ball bearings



⁷⁸⁾ According to igus® testing method ▶ Page 1210

⁸²⁾ Design standards ▶ Page 1209

Please note: Installation instructions ▶ Page 1212

Dimensions (inch)

Part No.	Nominal Size	Tolerance ⁷⁸⁾	d2 ISO h8	B ISO h10	B1 ISO H10	s	ds	dn ISO h10	do	o -0.004	e
RE7UI-03-08	1/2	.0016-.0032	.8673	1.2461	.9870	.0520	.8556	.8200	.7120	.1250	.2815
RE7UI-03-10	5/8	.0016-.0032	1.1173	1.4961	1.1360	.0620	1.1055	1.0600	.9620	.1250	.3125
RE7UI-03-12	3/4	.0016-.0032	1.2421	1.6173	1.1980	.0620	1.2300	1.1770	1.0870	.1250	.3125
RE7UI-03-16	1	.0016-.0032	1.5547	2.2421	1.7890	.0740	1.5271	1.4710	1.3990	.1250	.5000
RE7UI-03-20	1-1/4	.0020-.0041	1.9881	2.6173	2.0390	.0740	1.9606	1.8890	1.8370	.1250	.6250
RE7UI-03-24	1-1/2	.0020-.0041	2.3634	2.9921	2.4630	.0950	2.3358	2.2410	2.1520	.1620	.7500
RE7UI-03-32	2	.0024-.0051	2.9881	3.9921	3.2490	.1110	2.9606	2.8390	2.7750	.1890	1.0000

Housing Bore Recommendations

Nominal ID Size	Min.	Max.
3/8	0.6250	0.6257
1/2	0.8750	0.8758
5/8	1.1250	1.1258
3/4	1.2500	1.2510
1	1.5625	1.5635
1-1/4	2.0000	2.0010
1-1/2	2.3750	2.3760
2	3.0000	3.0010

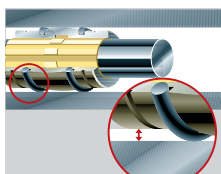

Technical Data

Part No.	F max, dynamic ⁸²⁾ p = 112 psi (lbs)	F max, static ⁸²⁾ p = 2611 psi (lbs)
RE7UI-03-08	169	788
RE7UI-03-10	220	1183
RE7UI-03-12	406	1538
RE7UI-03-16	596	2839
RE7UI-03-20	811	4143
RE7UI-03-24	1443	5679
RE7UI-03-32	2885	10099

Available with drylin® liners (most sizes)



J



E7



X

- X liner optional for chemicals/high temps up to +482°F (+250°C) for steel housing, up to +356°F (+180°C) for aluminum

drylin® R linear | Product Range

Closed, 303 stainless steel adapter (1.4305) - iglide® J liner

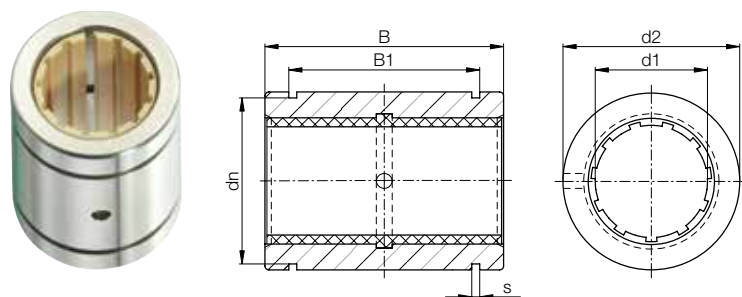

Order key

Type				Size	Option
R	J	U	I	-01-12	-ESR
Closed	iglide® J	Liner	Inch	Standard	Diameter
					Stainless steel

- Suitable shafting for iglide® J: drylin® AWI aluminum, SWI/SWI2 hardened steel, 300 series stainless Best shafting for X: hard-chrome and hard-stainless steel
- Secured by snap ring
- Dimensionally interchangeable with linear ball bearings

i ⁷⁸⁾ According to igus® testing method ► Page 1210
⁸²⁾ Design standards ► Page 1209
 Please note: Installation instructions ► Page 1212

Dimensions (inch)

Part No.	Nominal Size	Tolerance ⁷⁸⁾	d2 ISO h7	B ISO h10	B1 ISO H10	s	dn
RJUI-01-08ESR	1/2	.0016 - .0032	.8750	1.2500	.979	.0520	.8200
RJUI-01-10ESR	5/8	.0016 - .0032	1.1250	1.5000	1.124	.0620	1.0600
RJUI-01-12ESR	3/4	.0016 - .0032	1.2500	1.6200	1.186	.0620	1.1770
RJUI-01-16ESR	1	.0016 - .0032	1.5625	2.2500	1.773	.0740	1.4710
RJUI-01-20ESR	1-1/4	.0020 - .0041	2.0000	2.6200	2.023	.0740	1.8890
RJUI-01-24ESR	1-1/2	.0020 - .0041	2.3750	3.0000	2.440	.0950	2.2410

Housing Bore Recommendations

Nominal ID Size	Min.	Max.
1/2	0.8750	0.8758
5/8	1.1250	1.1258
3/4	1.2500	1.2510
1	1.5625	1.5635
1-1/4	2.0000	2.0010
1-1/2	2.3750	2.3760

Technical Data

Part No.	F max, dynamic ⁸²⁾ p = 725 psi (lbs)	F max, static ⁸²⁾ p = 5075 psi (lbs)
RJUI-01-08ESR	225	1575
RJUI-01-10ESR	338	2365
RJUI-01-12ESR	439	3077
RJUI-01-16ESR	811	5678
RJUI-01-20ESR	1184	8287
RJUI-01-24ESR	1622	11358

Available with drylin® liners (most sizes)



- X liner optional for chemicals/high temps up to +482°F (+250°C) for steel housing, up to +356°F (+180°C) for aluminum

drylin® R linear | Product Range

Closed, 303 stainless steel adapter (1.4305), Self-aligning - iglide® J liner

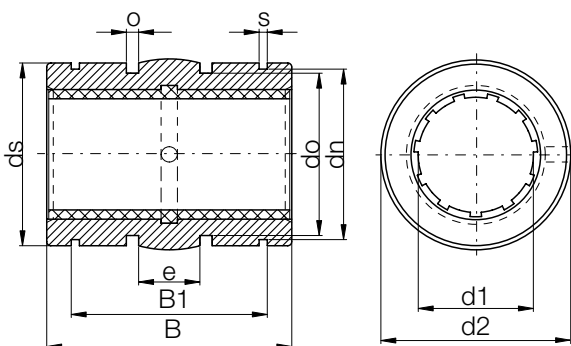

Order key

Type	Size	Option
R J U I -03-12-ESR		
Closed	iglide® J	Liner
	Inch	Self-aligning
	Diameter	Stainless steel

- Suitable shafting for iglide® J: drylin® AWI aluminum, SWI/SWI2 hardened steel, 300 series stainless Best shafting for X: hard-chrome and hard-stainless steel
- Secured by snap ring
- Dimensionally interchangeable with linear ball bearings



⁷⁸⁾ According to igus® testing method ► Page 1210

⁸²⁾ Design standards ► Page 1209

Please note: Installation instructions ► Page 1212

Dimensions (inch)

Part No.	Nominal Size	Tolerance ⁷⁸⁾	d2 ISO h8	B ISO h10	B1 ISO H10	s	ds	dn ISO h10	do	o -0.004	e
RJUI-03-08ESR	1/2	.0016-.0032	.8673	1.2461	.9870	.0520	.8556	.8200	.7120	.1250	.2815
RJUI-03-10ESR	5/8	.0016-.0032	1.1173	1.4961	1.1360	.0620	1.1055	1.0600	.9620	.1250	.3125
RJUI-03-12ESR	3/4	.0016-.0032	1.2421	1.6173	1.1980	.0620	1.2300	1.1770	1.0870	.1250	.3125
RJUI-03-16ESR	1	.0016-.0032	1.5547	2.2421	1.7890	.0740	1.5271	1.4710	1.3990	.1250	.5000
RJUI-03-20ESR	1-1/4	.0020-.0041	1.9881	2.6173	2.0390	.0740	1.9606	1.8890	1.8370	.1250	.6250
RJUI-03-24ESR	1-1/2	.0020-.0041	2.3634	2.9921	2.4630	.0950	2.3358	2.2410	2.1520	.1620	.7500

Housing Bore Recommendations

Nominal ID Size	Min.	Max.
1/2	0.8750	0.8758
5/8	1.1250	1.1258
3/4	1.2500	1.2510
1	1.5625	1.5635
1-1/4	2.0000	2.0010
1-1/2	2.3750	2.3760

Technical Data

Part No.	F max, dynamic ⁸²⁾ p = 725 psi (lbs)	F max, static ⁸²⁾ p = 5075 psi (lbs)
RJUI-03-08ESR	225	1575
RJUI-03-10ESR	338	2365
RJUI-03-12ESR	439	3077
RJUI-03-16ESR	811	5678
RJUI-03-20ESR	1184	8287
RJUI-03-24ESR	1622	11358

Available with drylin® liners (most sizes)



J



E7



X

- X liner optional for chemicals/high temps up to +482°F (+250°C) for steel housing, up to +356°F (+180°C) for aluminum

drylin® R linear | Product Range

Split, anodized aluminum adapter - iglide® J liner

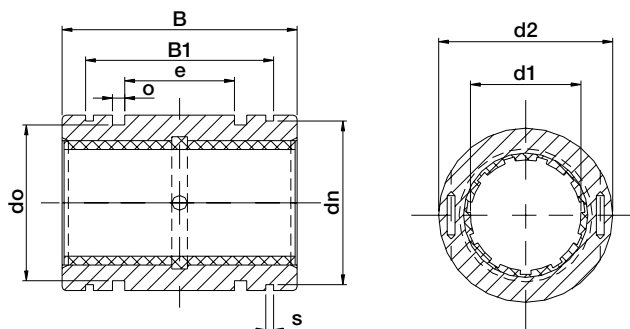

Size					Size
T	J	U	I	-01-10	
Split	iglide® J	Liner	Inch	Standard	Inner Ø d1

- Suitable shafting for iglide® J: drylin® AWI aluminum, SWI/SWI2 hardened steel, 300 series stainless Best shafting for X: hard-chrome and hard-stainless steel
- Secured by snap ring
- Dimensionally interchangeable with linear ball bearings

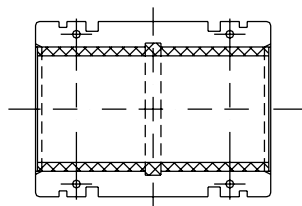

⁷⁸⁾ According to igus® testing method ► Page 1210
⁸²⁾ Design standards ► Page 1209
 Please note: Installation instructions ► Page 1212

Dimensions (inch)

Part No.	Nominal Size	Tolerance ⁷⁸⁾	d2 ISO h7	B ISO h10	B1 ISO H10	s	dn	e	o +.004	do
TJUI-01-08	1/2	.0016 - .0036	.8750	1.2500	.979	.0520	.8200	.281	.1250	.7120
TJUI-01-12	3/4	.0016 - .0036	1.2500	1.6200	1.186	.0620	1.1770	.312	.1250	1.0870
TJUI-01-16	1	.0016 - .0036	1.5625	2.2500	1.773	.0740	1.4710	.500	.1250	1.3990
TJUI-01-20	1-1/4	.0020 - .0039	2.0000	2.6200	2.023	.0740	1.8890	.625	.1250	1.8370
TJUI-01-24	1-1/2	.0024 - .0051	2.3750	3.0000	2.440	.0950	2.2410	.750	.1620	2.1520

Housing Bore Recommendations

Nominal ID Size	Min.	Max.
1/2	0.8750	0.8758
3/4	1.2500	1.2510
1	1.5625	1.5635
1-1/4	2.0000	2.0010
1-1/2	2.3750	2.3760

Technical Data

Part No.	F max, dynamic ⁸²⁾ p = 725 psi (lbs)	F max, static ⁸²⁾ p = 5075 psi (lbs)
TJUI-01-08	225	1575
TJUI-01-12	439	3077
TJUI-01-16	811	5678
TJUI-01-20	1184	8287
TJUI-01-24	1622	11358

Available with drylin® liners



J200



E7



X

- X liner optional for chemicals/high temps up to +482°F (+250°C) for steel housing, up to +356°F (+180°C) for aluminum

drylin® R linear | Product Range

Split, anodized aluminum adapter, low clearance - iglide® J liner

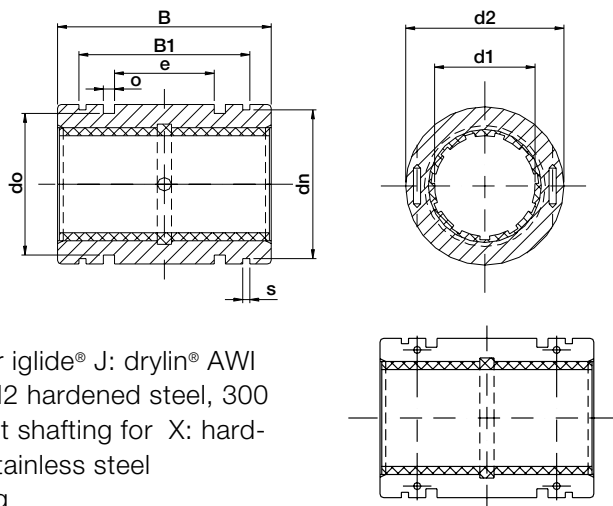

Order key

Size	Size
T	J
U	I
-11	-10
Split	iglide® J
Liner	Inch
Low clearance	Inner Ø d1

Part formerly known as TJUI-21-XX

- Suitable shafting for iglide® J: drylin® AWI aluminum, SWI/SWI2 hardened steel, 300 series stainless Best shafting for X: hard-chrome and hard-stainless steel
- Secured by snap ring
- Dimensionally interchangeable with linear ball bearings



⁷⁸⁾ According to igus® testing method ▶ Page 1210

⁸²⁾ Design standards ▶ Page 1209

Please note: Installation instructions ▶ Page 1212

Dimensions (inch)

Part No.	Nominal Size	Tolerance ⁷⁸⁾	d2 ISO h7	B ISO h10	B1 ISO H10	s	dn	e	o +.004	do
TJUI-11-08	1/2	.0008 -.0018	.8750	1.2500	.979	.0520	.8200	.281	.1250	.7120
TJUI-11-10	5/8	.0008 -.0018	1.1250	1.5000	1.124	.0620	1.0600	.312	.1250	.9620
TJUI-11-12	3/4	.0008 -.0018	1.2500	1.6200	1.186	.0620	1.1770	.312	.1250	1.0870
TJUI-11-16	1	.0008 -.0018	1.5625	2.2500	1.773	.0740	1.4710	.500	.1250	1.3990
TJUI-11-20	1-1/4	.0010 -.0020	2.0000	2.6200	2.023	.0740	1.8890	.625	.1250	1.8370
TJUI-11-24	1-1/2	.0010 -.0024	2.3750	3.0000	2.440	.0950	2.2410	.750	.1620	2.1520
TJUI-11-32	2	.0012 -.0029	3.0000	4.0000	3.222	.1110	2.8390	1.000	.1890	2.7750

Housing Bore Recommendations

Nominal ID Size	Min.	Max.
1/2	0.8750	0.8758
5/8	1.1250	1.1258
3/4	1.2500	1.2510
1	1.5625	1.5635
1-1/4	2.0000	2.0010
1-1/2	2.3750	2.3760
2	3.0000	3.0010

Technical Data

Part No.	F max, dynamic ⁸²⁾ p = 725 psi (lbs)	F max, static ⁸²⁾ p = 5075 psi (lbs)
TJUI-11-08	225	1575
TJUI-11-10	338	2365
TJUI-11-12	439	3077
TJUI-11-16	811	5678
TJUI-11-20	1184	8287
TJUI-11-24	1622	11358
TJUI-11-32	2885	20198

Available with drylin® liners (most sizes)



J200



E7



X

- X liner optional for chemicals/high temps up to +482°F (+250°C) for steel housing, up to +356°F (+180°C) for aluminum

drylin® R linear | Product Range

Split, anodized aluminum adapter, self-aligning - iglide® J liner

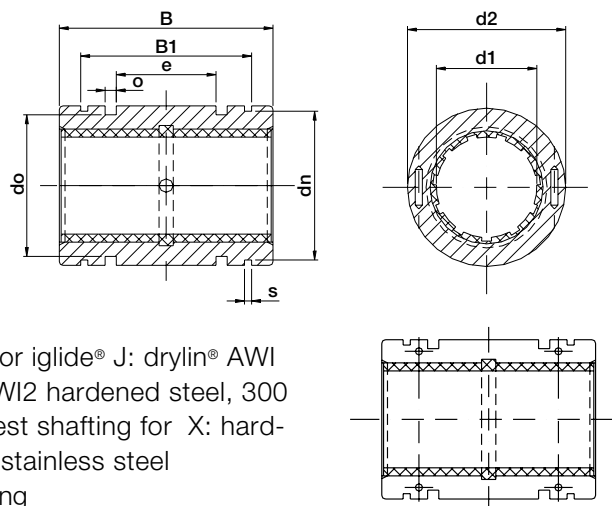

Order key

Size	Size
T	J
U	I
-03	-10
Split	iglide® J
Liner	Inch
Self-aligning	Inner Ø d1

- Suitable shafting for iglide® J: drylin® AWI aluminum, SWI/SWI2 hardened steel, 300 series stainless Best shafting for X: hard-chrome and hard-stainless steel
- Secured by snap ring
- Dimensionally interchangeable with linear ball bearings



⁷⁸⁾ According to igus® testing method ► Page 1210

⁸²⁾ Design standards ► Page 1209

Please note: Installation instructions ► Page 1212

Dimensions (inch)

Part No.	Nominal Size	Tolerance ⁷⁸⁾	d2 ISO h7	B ISO h10	B1 ISO H10	s	dn	e	o +.004	do	ds h10
TJUI-03-08	1/2	.0016 - .0036	.8750	1.2500	.979	.0520	.8200	.281	.1250	.7120	0.8563
TJUI-03-10	5/8	.0016 - .0036	1.1250	1.5000	1.124	.0620	1.0600	.312	.1250	.9620	1.1039
TJUI-03-12	3/4	.0016 - .0036	1.2500	1.6200	1.186	.0620	1.1770	.312	.1250	1.0870	1.2276
TJUI-03-16	1	.0016 - .0036	1.5625	2.2500	1.773	.0740	1.4710	.500	.1250	1.3990	1.5350
TJUI-03-20	1-1/4	.0020 - .0039	2.0000	2.6200	2.023	.0740	1.8890	.625	.1250	1.8370	1.9654
TJUI-03-24	1-1/2	.0020 - .0047	2.3750	3.0000	2.440	.0950	2.2410	.750	.1620	2.1520	2.3370
TJUI-03-32	2	.0024 - .0057	3.0000	4.0000	3.222	.1110	2.8390	1.000	.1890	2.7750	2.9531

Housing Bore Recommendations

Nominal ID Size	Min.	Max.
1/2	0.8750	0.8758
5/8	1.1250	1.1258
3/4	1.2500	1.2510
1	1.5625	1.5635
1-1/4	2.0000	2.0010
1-1/2	2.3750	2.3760
2	3.0000	3.0010

Technical Data

Part No.	F max, dynamic ⁸²⁾ p = 725 psi (lbs)	F max, static ⁸²⁾ p = 5075 psi (lbs)
TJUI-03-08	225	1575
TJUI-03-10	338	2365
TJUI-03-12	439	3077
TJUI-03-16	811	5678
TJUI-03-20	1184	8287
TJUI-03-24	1622	11358
TJUI-03-32	2885	20198

Available with drylin® liners (most sizes)



J200



E7



X

- X liner optional for chemicals/high temps up to +482°F (+250°C) for steel housing, up to +356°F (+180°C) for aluminum

drylin® R linear | Product Range

Split, anodized aluminum adapter - iglide® E7 liner

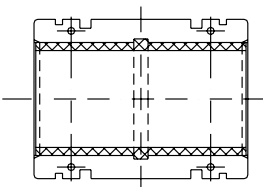
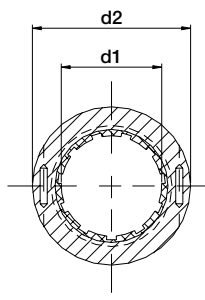
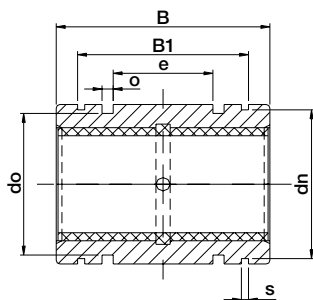

Order key

Type	Size
T E7 U I -01 -10	
Split	Inner Ø d1
iglide® E7	
Liner	
Inch	
Standard	

- Suitable shafting: SWI case-hardened, 300 series stainless, hard-chrome and EW/EEWI hard-stainless steel
- Secured by snap ring
- Dimensionally interchangeable with linear ball bearings



⁷⁸⁾ According to igus® testing method ▶ Page 1210

⁸²⁾ Design standards ▶ Page 1209

Please note: Installation instructions ▶ Page 1212

Dimensions (inch)

Part No.	Nominal Size	Tolerance ⁷⁸⁾	d2 ISO h7	B ISO h10	B1 ISO H10	s	dn	e	o +.004	do
TE7UI-01-08	1/2	.0016 - .0036	.8750	1.2500	.979	.0520	.8200	.281	.1250	.7120
TE7UI-01-10	5/8	.0016 - .0036	1.1250	1.5000	1.124	.0620	1.0600	.312	.1250	.9620
TE7UI-01-12	3/4	.0016 - .0036	1.2500	1.6200	1.186	.0620	1.1770	.312	.1250	1.0870
TE7UI-01-16	1	.0016 - .0036	1.5625	2.2500	1.773	.0740	1.4710	.500	.1250	1.3990
TE7UI-01-20	1-1/4	.0020 - .0039	2.0000	2.6200	2.023	.0740	1.8890	.625	.1250	1.8370
TE7UI-01-24	1-1/2	.0020 - .0047	2.3750	3.0000	2.440	.0950	2.2410	.750	.1620	2.1520
TE7UI-01-32	2	.0024 - .0057	3.0000	4.0000	3.222	.1110	2.8390	1.000	.1890	2.7750

Housing Bore Recommendations

Nominal ID Size	Min.	Max.
1/2	0.8750	0.8758
5/8	1.1250	1.1258
3/4	1.2500	1.2510
1	1.5625	1.5635
1-1/4	2.0000	2.0010
1-1/2	2.3750	2.3760
2	3.0000	3.0010

Technical Data

Part No.	F max, dynamic ⁸²⁾ p = 362 psi (lbs)	F max, static ⁸²⁾ p = 2611 psi (lbs)
TE7UI-01-08	113	788
TE7UI-01-10	169	1183
TE7UI-01-12	220	1539
TE7UI-01-16	406	2839
TE7UI-01-20	592	4144
TE7UI-01-24	811	5679
TE7UI-01-32	1443	10099

Available with drylin® liners (most sizes)



J



J200



X

- X liner optional for chemicals/high temps up to +482°F (+250°C) for steel housing, up to +356°F (+180°C) for aluminum

drylin® R linear | Product Range

Split, anodized aluminum adapter, Self-aligning - iglide® E7 liner

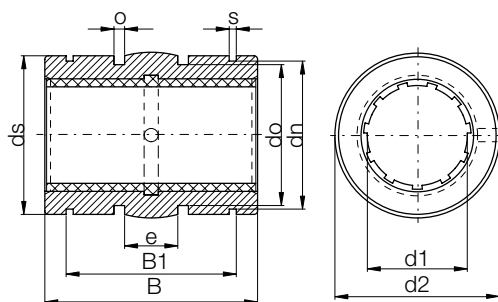

Order key

Type					Size
T E7 U I -03-10					
Split	iglide® E7	Liner	Inch	Self-aligning	Inner Ø d1

- Suitable shafting: SWI case-hardened, 300 series stainless, hard-chrome and EWI/EEWI hard-stainless steel
- Secured by snap ring
- Dimensionally interchangeable with linear ball bearings



⁷⁸⁾ According to igus® testing method ► Page 1210

⁸²⁾ Design standards ► Page 1209

Please note: Installation instructions ► Page 1212

Dimensions (inch)

Part No.	Nominal Size	Tolerance ⁷⁸⁾	d2 ISO h7	B ISO h10	B1 ISO H10	s	dn	e	o +.004	do	ds h10
TE7UI-03-08	1/2	.0016 - .0036	.8750	1.2500	.979	.0520	.8200	.281	.1250	.7120	0.8563
TE7UI-03-10	5/8	.0016 - .0036	1.1250	1.5000	1.124	.0620	1.0600	.312	.1250	.9620	1.1039
TE7UI-03-12	3/4	.0016 - .0036	1.2500	1.6200	1.186	.0620	1.1770	.312	.1250	1.0870	1.2276
TE7UI-03-16	1	.0016 - .0036	1.5625	2.2500	1.773	.0740	1.4710	.500	.1250	1.3990	1.5350
TE7UI-03-20	1-1/4	.0020 - .0039	2.0000	2.6200	2.023	.0740	1.8890	.625	.1250	1.8370	1.9654
TE7UI-03-24	1-1/2	.0020 - .0047	2.3750	3.0000	2.440	.0950	2.2410	.750	.1620	2.1520	2.3370
TE7UI-03-32	2	.0024 - .0057	3.0000	4.0000	3.222	.1110	2.8390	1.000	.1890	2.7750	2.9531

Housing Bore Recommendations

Nominal ID Size	Min.	Max.
1/2	0.8750	0.8758
5/8	1.1250	1.1258
3/4	1.2500	1.2510
1	1.5625	1.5635
1-1/4	2.0000	2.0010
1-1/2	2.3750	2.3760
2	3.0000	3.0010

Technical Data

Part No.	F max, dynamic ⁸²⁾ p = 362 psi (lbs)	F max, static ⁸²⁾ p = 2611 psi (lbs)
TE7UI-03-08	113	788
TE7UI-03-10	169	1183
TE7UI-03-12	220	1539
TE7UI-03-16	406	2839
TE7UI-03-20	592	4144
TE7UI-03-24	811	5679
TE7UI-03-32	1443	10099

Available with drylin® liners (most sizes)



J



J200



X

- X liner optional for chemicals/high temps up to +482°F (+250°C) for steel housing, up to +356°F (+180°C) for aluminum

drylin® R linear | Product Range

Open, anodized aluminum adapter - iglide® J liner

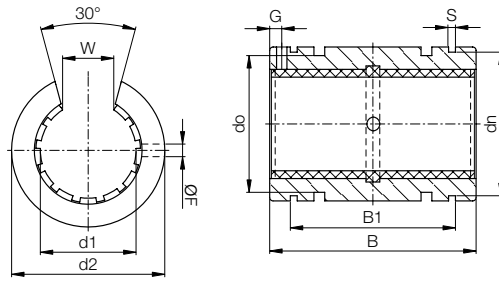
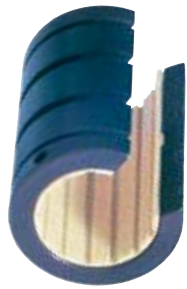

Order key

Size	Size
O	J U I -01-10
Open	iglide® J
	Liner
	Inch
	Standard
	Inner Ø d1

- Suitable shafting for iglide® J: drylin® AWUI hard anodized aluminum, SWI/SWI2 hard stainless. Best shafting for X: EWUI hard stainless steel
- Dimensionally interchangeable with linear ball bearings



⁷⁸⁾ According to igus® testing method ► Page 1210

⁸²⁾ Design standards ► Page 1209

Please note: Installation instructions ► Page 1212

Dimensions (inch)

Part No..	Ø Shaft	Tolerance ⁷⁸⁾	d2	B	W	s	dn	B1	F	G	do
			ISO h7	ISO h10	±0.012	ISO h10	ISO H10	+0.004	+0.004		
OJUI-01-08	1/2	.0016 - .0032	.8750	1.2500	.3940	.0520	.8200	.979	.1360	.6250	.684
OJUI-01-10	5/8	.0016 - .0032	1.1250	1.5000	.4330	.0620	1.0600	1.124	.1360	.1250	.934
OJUI-01-12	3/4	.0016 - .0032	1.2500	1.6250	.4920	.0620	1.1770	1.186	.1360	.1250	1.059
OJUI-01-16	1	.0016 - .0032	1.5625	2.2500	.6300	.0740	1.4710	1.773	.1360	.1250	1.372
OJUI-01-20	1-1/4	.0020 - .0041	2.0000	2.6250	.7090	.0740	1.8890	2.023	.2010	.1875	1.809
OJUI-01-24	1-1/2	.0020 - .0041	2.3750	3.0000	.8660	.0950	2.2410	2.440	.2010	.1875	2.113
OJUI-01-32	2	.0024 - .0051	3.0000	4.0000	1.1810	.1110	2.8390	3.222	.2650	.3125	2.738

Housing Bore Recommendations

Nominal ID Size	Min.	Max.
1/2	0.8750	0.8758
5/8	1.1250	1.1258
3/4	1.2500	1.2510
1	1.5625	1.5635
1-1/4	2.0000	2.0010
1-1/2	2.3750	2.3760
2	3.0000	3.0010

Technical Data

Part No.	F max. dynamic ⁸²⁾ [lbs]			F max. static ⁸²⁾ [lbs]		
	P = 725 psi					
	0°	90°	180°	0°	90°	180°
OJUI-01-08	226	154	80	1585	1078	555
OJUI-01-10	340	231	118	2378	1617	832
OJUI-01-12	408	277	143	2854	1942	998
OJUI-01-16	590	400	206	4123	2804	1443
OJUI-01-20	1189	809	416	8323	5659	2912
OJUI-01-24	1631	1109	571	11418	7765	3996
OJUI-01-32	2900	1972	1015	20300	13804	7104

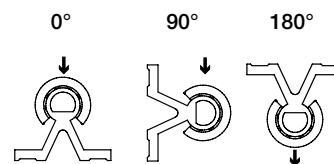

Available with drylin® liners (*available in most sizes, consult igus®)



J200*



E7*



X

- X liner optional for chemicals/high temps up to +482°F (+250°C) for steel housing, up to +356°F (+180°C) for aluminum

drylin® R linear | Product Range

Open, anodized aluminum adapter, low clearance - iglide® J liner

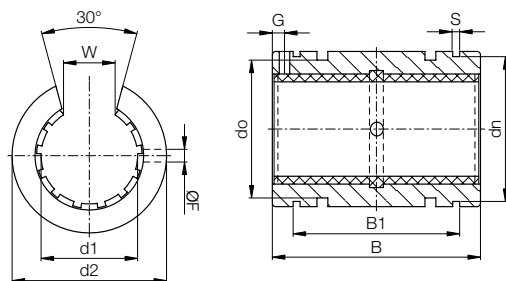

Order key

Size	Size
O	J U I -11-10
Open	iglide® J
	Liner
	Inch
	Low-clearance
	Inner Ø d1

- Suitable shafting for iglide® J: drylin® AWUI hard anodized aluminum, SWI/SWI2 hard stainless. Best shafting for X: EWUI hard stainless steel
- Dimensionally interchangeable with linear ball bearings

Part formerly known as OJUI-21-XX



⁷⁸⁾ According to igus® testing method ▶ Page 1210

⁸²⁾ Design standards ▶ Page 1209

Please note: Installation instructions ▶ Page 1212

Dimensions (inch)

Part No..	Ø Shaft	Tolerance ⁷⁸⁾	d2	B	W	s	dn	B1	F	G	do
			ISO h7	ISO h10	±0.012	ISO h10	ISO H10	+0.004	+0.004		
OJUI-11-08	1/2	.0008 - .0016	.8750	1.2500	.3940	.0520	.8200	.979	.1360	.6250	.684
OJUI-11-10	5/8	.0008 - .0016	1.1250	1.5000	.4330	.0620	1.0600	1.124	.1360	.1250	.934
OJUI-11-12	3/4	.0008 - .0016	1.2500	1.6250	.4920	.0620	1.1770	1.186	.1360	.1250	1.059
OJUI-11-16	1	.0008 - .0016	1.5625	2.2500	.6300	.0740	1.4710	1.773	.1360	.1250	1.372
OJUI-11-20	1-1/4	.0010 - .0021	2.0000	2.6250	.7090	.0740	1.8890	2.023	.2010	.1875	1.809
OJUI-11-24	1-1/2	.0010 - .0021	2.3750	3.0000	.8660	.0950	2.2410	2.440	.2010	.1875	2.113
OJUI-11-32	2	.0012 - .0026	3.0000	4.0000	1.1810	.1110	2.8390	3.222	.2650	.3125	2.738

Housing Bore Recommendations

Nominal ID Size	Tolerance	
	Min.	Max.
1/2	0.8750	0.8758
5/8	1.1250	1.1258
3/4	1.2500	1.2510
1	1.5625	1.5635
1-1/4	2.0000	2.0010
1-1/2	2.3750	2.3760
2	3.0000	3.0010

Technical Data

Part No.	F max. dynamic ⁸²⁾ [lbs]			F max. static ⁸²⁾ [lbs]		
	P = 725 psi			P = 5075 psi		
	0°	90°	180°	0°	90°	180°
OJUI-11-08	226	154	80	1585	1078	555
OJUI-11-10	340	231	118	2378	1617	832
OJUI-11-12	408	277	143	2854	1942	998
OJUI-11-16	590	400	206	4123	2804	1443
OJUI-11-20	1189	809	416	8323	5659	2912
OJUI-11-24	1631	1109	571	11418	7765	3996
OJUI-11-32	2900	1972	1015	20300	13804	7104

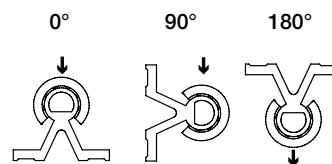

drylin® R linear | Product Range

Open, anodized aluminum adapter, self-aligning - iglide® J liner

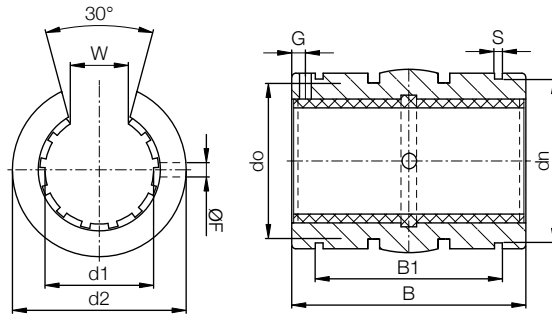

Order key

Size					Size
O	J	U	I	-03-10	
Open	iglide® J	Liner	Inch	Self-aligning	Inner Ø d1

- Suitable shafting for iglide® J: drylin® AWUI hard anodized aluminum, SWI/SWI2 hard stainless. Best shafting for X: EWUI hard stainless steel
- Dimensionally interchangeable with linear ball bearings



⁷⁸⁾ According to igus® testing method ► Page 1210
⁸²⁾ Design standards ► Page 1209
 Please note: Installation instructions ► Page 1212

Dimensions (inch)

Part No.	Ø Shaft	Tolerance ⁸²⁾	d2	ds	F	G	do	B1	s	dn	B	W
			ISO h8	ISO h10	+0.004	+0.004	ISO H10	ISO H10	ISO h10	ISO h10	ISO h10	+0.012
OJUI-03-08	1/2	.0016 - .0032	.8673	.8556	.1360	.6250	.6846	.987	.0520	.8200	1.2461	.3940
OJUI-03-10	5/8	.0016 - .0032	1.1173	1.1055	.1360	.1250	.9346	1.136	.0620	1.0600	1.4961	.4330
OJUI-03-12	3/4	.0016 - .0032	1.2421	1.2300	.1360	.1250	1.0590	1.198	.0620	1.1770	1.6173	.4920
OJUI-03-16	1	.0016 - .0032	1.5547	1.5271	.1360	.1250	1.3720	1.789	.0740	1.4710	2.2421	.6300
OJUI-03-20	1-1/4	.0020 - .0041	1.9881	1.9606	.2010	.1875	1.8094	2.039	.0740	1.8890	2.6173	.7090
OJUI-03-24	1-1/2	.0020 - .0041	2.3634	2.3358	.2010	.1875	2.1130	2.463	.0950	2.2410	2.9921	.8660
OJUI-03-32	2	.0024 - .0051	2.988	2.9606	.2650	.3125	2.7378	3.249	.1110	2.8390	3.9921	1.1810

Housing Bore Recommendations

Nominal ID Size	Min. Max.	
	1/2	0.8750
5/8	1.1250	1.1258
3/4	1.2500	1.2510
1	1.5625	1.5635
1-1/4	2.0000	2.0010
1-1/2	2.3750	2.3760
2	3.0000	3.0010

Technical Data

Part No.	F max. dynamic ⁸²⁾ [lbs]			F max. static ⁸²⁾ [lbs]		
	P = 725 psi					
	0°	90°	180°	0°	90°	180°
OJUI-03-08	226	154	80	1585	1078	555
OJUI-03-10	340	231	118	2378	1617	832
OJUI-03-12	408	277	143	2854	1942	998
OJUI-03-16	590	400	206	4123	2804	1443
OJUI-03-20	1189	809	416	8323	5659	2912
OJUI-03-24	1631	1109	571	11418	7765	3996
OJUI-03-32	2900	1972	1015	20300	13804	7104

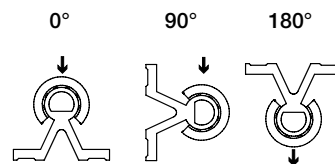

Available with drylin® liners (*available in most sizes, consult igus®)



J200*



E7*



X

- X liner optional for chemicals/high temps up to +482°F (+250°C) for steel housing, up to +356°F (+180°C) for aluminum

drylin® R linear | Product Range

Open, anodized aluminum adapter - iglide® E7 liner
For steel, hard chrome steel, and stainless steel

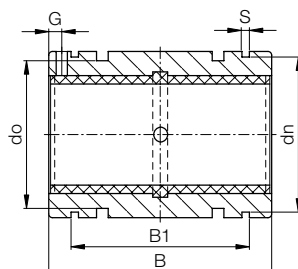
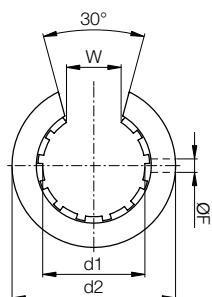

Order key

Type	Size
O E7 U I -01 -10	
Open	iglide® E7
	Liner
	Inch
	Standard
	Inner Ø d1

- Suitable shafting for iglide® E7: drylin® AWI aluminum, case-hardened, 300 series stainless Best shafting for X: hard-chrome and hard-stainless steel
- Dimensionally interchangeable with linear ball bearings



⁷⁸⁾ According to igus® testing method ► Page 1210

⁸²⁾ Design standards ► Page 1209

Please note: Installation instructions ► Page 1212

Dimensions (inch)

Part No..	Ø Shaft	Tolerance™	d2	B	W	s	dn	B1	F	G	do
			ISO h7	ISO h10	±0.012	ISO h10	ISO H10	+0.004	+0.004		
OE7UI-01-08	1/2	.0016 - .0032	.8750	1.2500	.3940	.0520	.8200	.979	.1360	.6250	.684
OE7UI-01-10	5/8	.0016 - .0032	1.1250	1.5000	.4330	.0620	1.0600	1.124	.1360	.1250	.934
OE7UI-01-12	3/4	.0016 - .0032	1.2500	1.6250	.4920	.0620	1.1770	1.186	.1360	.1250	1.059
OE7UI-01-16	1	.0016 - .0032	1.5625	2.2500	.6300	.0740	1.4710	1.773	.1360	.1250	1.372
OE7UI-01-20	1-1/4	.0020 - .0041	2.0000	2.6250	.7090	.0740	1.8890	2.023	.2010	.1875	1.809
OE7UI-01-24	1-1/2	.0020 - .0041	2.3750	3.0000	.8660	.0950	2.2410	2.440	.2010	.1875	2.113
OE7UI-01-32	2	.0024 - .0051	3.0000	4.0000	1.1810	.1110	2.8390	3.222	.2650	.3125	2.738

Housing Bore Recommendations

Nominal ID Size	Min. Max.	
	1/2	0.8750
5/8	1.1250	1.1258
3/4	1.2500	1.2510
1	1.5625	1.5635
1-1/4	2.0000	2.0010
1-1/2	2.3750	2.3760
2	3.0000	3.0010

Technical Data

Part No.	F max. dynamic ⁸²⁾ [lbs]			F max. static ⁸²⁾ [lbs]		
	P = 362 psi					
	0°	90°	180°	0°	90°	180°
OE7UI-01-08	113	77	40	793	539	278
OE7UI-01-10	170	116	59	1189	809	416
OE7UI-01-12	204	139	72	1427	971	499
OE7UI-01-16	295	200	103	2062	1402	722
OE7UI-01-20	595	405	208	4162	2830	1456
OE7UI-01-24	816	555	286	5709	3883	1998
OE7UI-01-32	1450	986	508	10150	6902	3552

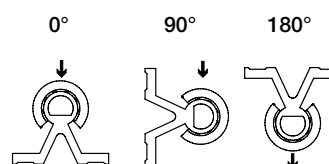

Available with drylin® liners (*available in most sizes, consult igus®)



J200*



E7*



X

- X liner optional for chemicals/high temps up to +482°F (+250°C) for steel housing, up to +356°F (+180°C) for aluminum

drylin® R linear | Product Range

Open, anodized aluminum adapter, self-aligning - iglide® E7 liner
For steel, hard chrome steel, and stainless steel

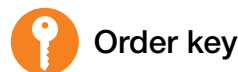
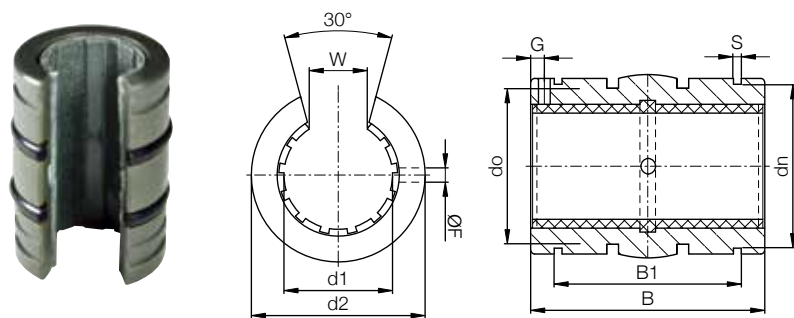

Type	Size
O E7 U I -03-10	
Open	iglide® E7
Liner	Inch
Self-aligning	Inner Ø d1

- Suitable shafting for iglide® E7: case-hardened, 300 series stainless, hard-chrome and hard-stainless steel
- Dimensionally interchangeable with linear ball bearings



⁷⁸⁾ According to igus® testing method ▶ Page 1210

⁸²⁾ Design standards ▶ Page 1209

Please note: Installation instructions ▶ Page 1212

Dimensions (inch)

Part No.	Ø Shaft	Tolerance ⁷⁸⁾	d2	ds	F	G	do	B1	s	dn	B	W
			ISO h8	ISO h10	+0.004	+0.004	ISO H10	ISO H10	ISO h10	ISO h10	+0.012	
OE7UI-03-08	1/2	.0016 -.0032	.8673	.8556	.1360	.6250	.6846	.987	.0520	.8200	1.2461	.3940
OE7UI-03-10	5/8	.0016 -.0032	1.1173	1.1055	.1360	.1250	.9346	1.136	.0620	1.0600	1.4961	.4330
OE7UI-03-12	3/4	.0016 -.0032	1.2421	1.2300	.1360	.1250	1.0590	1.198	.0620	1.1770	1.6173	.4920
OE7UI-03-16	1	.0016 -.0032	1.5547	1.5271	.1360	.1250	1.3720	1.789	.0740	1.4710	2.2421	.6300
OE7UI-03-20	1-1/4	.0020 -.0041	1.9881	1.9606	.2010	.1875	1.8094	2.039	.0740	1.8890	2.6173	.7090
OE7UI-03-24	1-1/2	.0020 -.0041	2.3634	2.3358	.2010	.1875	2.1130	2.463	.0950	2.2410	2.9921	.8660
OE7UI-03-32	2	.0024 -.0051	2.988	2.9606	.2650	.3125	2.7378	3.249	.1110	2.8390	3.9921	1.1810

Housing Bore Recommendations

Nominal ID Size	Min. Max.	
	1/2	0.8750
5/8	1.1250	1.1258
3/4	1.2500	1.2510
1	1.5625	1.5635
1-1/4	2.0000	2.0010
1-1/2	2.3750	2.3760
2	3.0000	3.0010

Technical Data

Part No.	F max. dynamic ⁸²⁾ [lbs]			F max. static ⁸²⁾ [lbs]		
	P = 362 psi					
	0°	90°	180°	0°	90°	180°
OE7UI-03-08	113	77	40	793	539	278
OE7UI-03-10	170	116	59	1189	809	416
OE7UI-03-12	204	139	72	1427	971	499
OE7UI-03-16	295	200	103	2062	1402	722
OE7UI-03-20	595	405	208	4162	2830	1456
OE7UI-03-24	816	555	286	5709	3883	1998
OE7UI-03-32	1450	986	508	10150	6902	3552

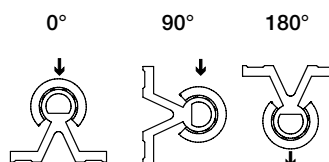

Available with drylin® liners (*available in most sizes, consult igus®)



J200*



E7*



X

- X liner optional for chemicals/high temps up to +482°F (+250°C) for steel housing, up to +356°F (+180°C) for aluminum

Notes

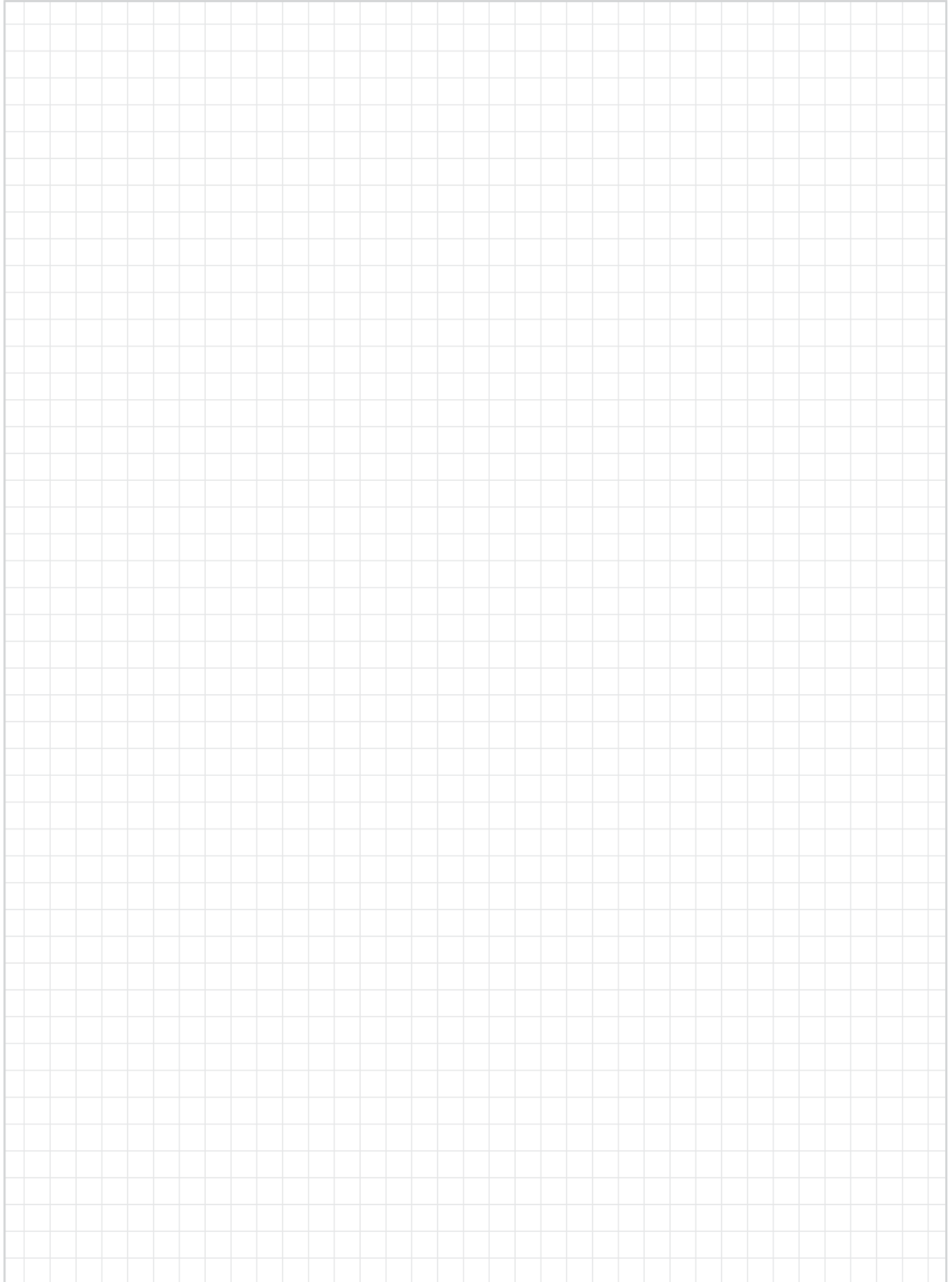

drylin® R pillow blocks | Product Range

Closed, anodized aluminum, pillow block, iglide® J

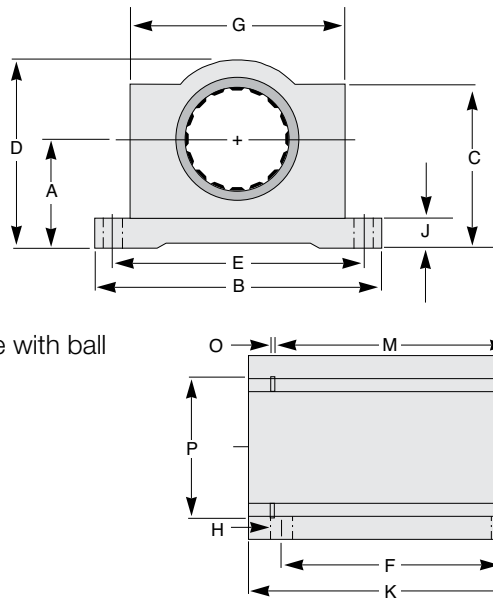
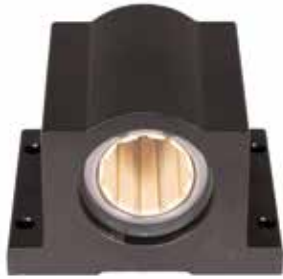

Order key

Type	Size
R J U I - XX - 10	
Closed	
iglide® J	
Liner	
Inch	
-41 = Standard -43 = Self-aligning -51 = Low clearance	
Inner Ø d1	

Part RJUI-41-XX was formerly known as RJUI-11-XX

- Low clearance liners optional
- Dimensionally interchangeable with ball bearings

Dimensions (inch)

Part No.	Nom. Size	A ±.001	B	C	D ±.010	E ±.010	F	G	H BOLT HOLE	J	K	M	O	P	
RJZI-□-04	1/4	0.437	1.625	0.750	0.813	1.312	0.750	1.000	#6	5/32	0.188	1.188	0.750	0.039	0.532
RJUI-□-06	3/8	0.500	1.750	0.875	0.938	1.437	0.875	1.125	#6	5/32	0.188	1.313	0.875	0.039	0.665
RJUI-□-08	1/2	0.687	2.000	1.125	1.250	1.688	1.000	1.375	#6	5/32	0.250	1.688	1.250	0.046	0.931
RJUI-□-10	5/8	0.875	2.500	1.438	1.625	2.125	1.125	1.750	#8	3/16	0.281	1.938	1.500	0.056	1.197
RJUI-□-12	3/4	0.937	2.750	1.563	1.750	2.375	1.250	1.875	#8	3/16	0.313	2.063	1.625	0.056	1.330
RJUI-□-16	1	1.187	3.250	1.938	2.188	2.875	1.750	2.375	#10	7/32	0.375	2.813	2.250	0.068	1.671
RJUI-□-20	1-1/4	1.500	4.000	2.500	2.813	3.500	2.000	3.000	#10	7/32	0.438	3.625	2.625	0.068	2.122
RJUI-□-24	1-1/2	1.750	4.750	2.875	3.250	4.125	2.500	3.500	1/4	9/32	0.500	4.000	3.000	0.086	2.519
RJUI-□-32	2	2.125	6.000	3.625	4.063	5.250	3.250	4.500	3/8	13/32	0.625	5.000	4.000	0.103	3.182

Supplement the part number with one of the following options.
Example: RJUI-43-08 for a self-aligning version

- For Standard bearing use **41**
- For Self-aligning bearing use **43**
- For Low clearance use **51**

Technical Data

Part No.	Dynamic Load (lbs)	Static Load (lbs)
	P = 725 psi	P = 5075 psi
RJZI-XX-04	135	946
RJUI-XX-06	118	828
RJUI-XX-08	225	1575
RJUI-XX-10	338	2365
RJUI-XX-12	439	3077
RJUI-XX-16	811	5678
RJUI-XX-20	1184	8287
RJUI-XX-24	1622	11358
RJUI-XX-32	2885	20198

Available with drylin® liners



J200*



E7*



X

- X liner optional for chemicals/high temps up to +482°F (+250°C) for steel housing, up to +356°F (+180°C) for aluminum

drylin® R pillow blocks | Product Range

Open, anodized aluminum, pillow block, iglide® J

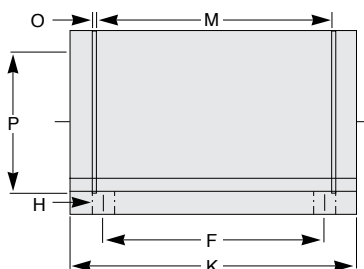
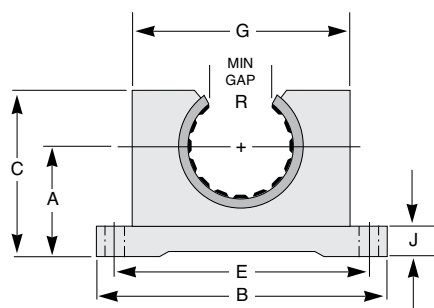

- Low clearance liners optional
- Dimensionally interchangeable with ball bearings

Order key

Type	Size
O J U I - XX - 10	
Open	
iglide® J	
Liner	
Inch	
-41 = Standard -43 = Self-aligning -51 = Low clearance	
Inner Ø d1	

Part OJUI-41-XX was formerly known as OJUI-11-XX

Dimensions (inch)

Part No.	Nom. Size	A ±.001	B	C	E ±.010	F ±.010	G	BOLT HOLE		J	K	M	O	P	R
								#	Ø						
OJUI-□-08	1/2	0.687	2.000	1.125	1.688	1.000	1.375	#6	5/32	0.250	1.688	1.250	0.046	0.931	0.313
OJUI-□-10	5/8	0.875	2.500	1.438	2.125	1.125	1.750	#8	3/16	0.281	1.938	1.500	0.056	1.197	0.375
OJUI-□-12	3/4	0.937	2.750	1.563	2.375	1.250	1.875	#8	3/16	0.313	2.063	1.625	0.056	1.330	0.438
OJUI-□-16	1	1.187	3.250	1.938	2.875	1.750	2.375	#10	7/32	0.375	2.813	2.250	0.068	1.671	0.563
OJUI-□-20	1-1/4	1.500	4.000	2.500	3.500	2.000	3.000	#10	7/32	0.438	3.625	2.625	0.068	2.122	0.625
OJUI-□-24	1-1/2	1.750	4.750	2.875	4.125	2.500	3.500	1/4	9/32	0.500	4.000	3.000	0.086	2.519	0.750
OJUI-□-32	2	2.125	6.000	3.625	5.250	3.250	4.500	3/8	13/32	0.625	5.000	4.000	0.103	3.182	1.000

Supplement the part number with one of the following options.
Example: OJUI-43-08 for a self-aligning version

- For Standard bearing use 41
- For Self-aligning bearing use 43
- For Low clearance use 51

Technical Data

Part No.	Dynamic Load (lbs)	Static Load (lbs)
	P = 725 psi	P = 5075 psi
OJUI-XX-08	225	1575
OJUI-XX-10	338	2365
OJUI-XX-12	439	3077
OJUI-XX-16	811	5678
OJUI-XX-20	1184	8287
OJUI-XX-24	1622	11358
OJUI-XX-32	2885	20198

Available with drylin® liners



J200*



E7*



X

- X liner optional for chemicals/high temps up to +482°F (+250°C) for steel housing, up to +356°F (+180°C) for aluminum

drylin® R pillow blocks | Product Range

Closed, anodized aluminum, twin pillow block, iglide® J

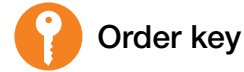
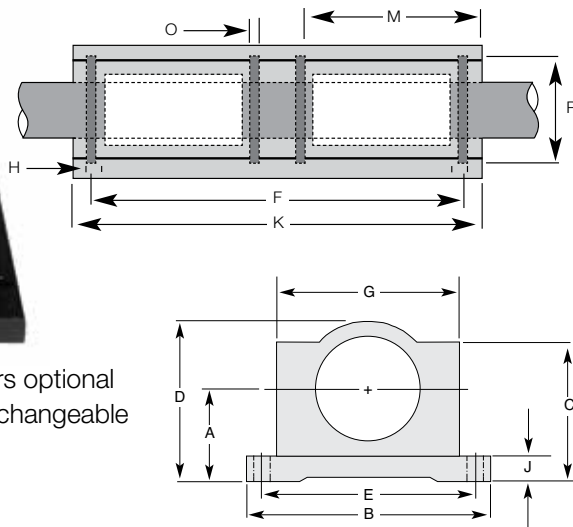

Type	Size	Style
R J U I - XX - 10 TW		
Closed		
iglide® J		
Liner		
Inch		
-41 = Standard -43 = Self-aligning -51 = Low clearance		
Inner Ø d1		
Twin pillow block		

- Low clearance liners optional
- Dimensionally interchangeable with ball bearings

Part RJUI-41-XX was formerly known as RJUI-11-XX

Dimensions (inch)

Part No.	Nom. Size	A ±.001	B	C	D ±.010	E ±.010	F	G	H BOLT	J HOLE	K	M	O	P	
RJZI-□-04TW	1/4	0.437	1.625	0.750	0.813	1.312	2.000	1.000	#6	5/32	0.188	2.500	0.750	0.039	0.532
RJUI-□-06TW	3/8	0.500	1.750	0.875	0.938	1.437	2.250	1.125	#6	5/32	0.188	2.750	0.875	0.039	0.665
RJUI-□-08TW	1/2	0.687	2.000	1.125	1.250	1.688	2.500	1.375	#6	5/32	0.250	3.500	1.250	0.046	0.931
RJUI-□-10TW	5/8	0.875	2.500	1.438	1.625	2.125	3.000	1.750	#8	3/16	0.281	4.000	1.500	0.056	1.197
RJUI-□-12TW	3/4	0.937	2.750	1.563	1.750	2.375	3.500	1.875	#8	3/16	0.313	4.500	1.625	0.056	1.330
RJUI-□-16TW	1	1.187	3.250	1.938	2.188	2.875	4.500	2.375	#10	7/32	0.375	6.000	2.250	0.068	1.671
RJUI-□-20TW	1-1/4	1.500	4.000	2.500	2.813	3.500	5.500	3.000	#10	7/32	0.438	7.500	2.625	0.068	2.122
RJUI-□-24TW	1-1/2	1.750	4.750	2.875	3.250	4.125	6.500	3.500	1/4	9/32	0.500	9.000	3.000	0.086	2.519
RJUI-□-32TW	2	2.125	6.000	3.625	4.063	5.250	8.250	4.500	3/8	13/32	0.625	10.000	4.000	0.103	3.182

Supplement the part number with one of the following options.
Example: RJUI-43-08TW for a self-aligning version

- For Standard bearing use **41**
- For Self-aligning bearing use **43**
- For Low clearance use **51**

Technical Data

Part No.	Dynamic Load (lbs) P = 725 psi	Static Load (lbs) P = 5075 psi
RJZI-□-04TW	270	1892
RJUI-□-06TW	236	1656
RJUI-□-08TW	450	3150
RJUI-□-10TW	676	4730
RJUI-□-12TW	878	6154
RJUI-□-16TW	1622	11356
RJUI-□-20TW	2368	16574
RJUI-□-24TW	3244	22716
RJUI-□-32TW	5770	40396

Available with drylin® liners



J200*



E7*



X

- X liner optional for chemicals/high temps up to +482°F (+250°C) for steel housing, up to +356°F (+180°C) for aluminum

drylin® R pillow blocks | Product Range

Open, anodized aluminum, twin pillow block, iglide® J

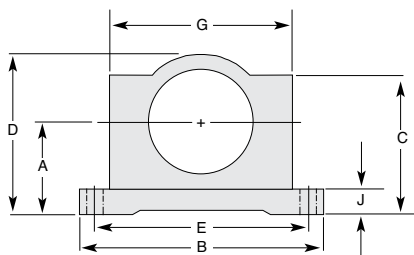
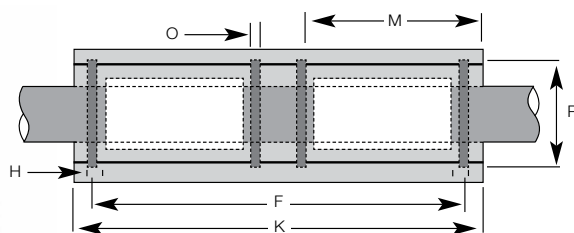

- Low clearance liners optional
- Dimensionally interchangeable with ball bearings



Order key

Type	Size	Style
O J U I - XX -10 TW		
Open	iglide® J	Liner
Inch	-41 = Standard -43 = Self-aligning -51 = Low clearance	Inner Ø d1 Twin pillow block

Part OJUI-41-XX was formerly known as OJUI-11-XX

Dimensions (inch)

Part No.	Nom. Size	A ±.001	B	C	E ±.010	F ±.010	G	H BOLT	J HOLE	K	M	O	P	R	
OJUI-□-08TW	1/2	0.687	2.000	1.125	1.688	2.500	1.375	#6	5/32	0.250	3.500	1.250	0.046	0.931	0.313
OJUI-□-10TW	5/8	0.875	2.500	1.438	2.125	3.000	1.750	#8	3/16	0.281	4.000	1.500	0.056	1.197	0.375
OJUI-□-12TW	3/4	0.937	2.750	1.563	2.375	3.500	1.875	#8	3/16	0.313	4.500	1.625	0.056	1.330	0.438
OJUI-□-16TW	1	1.187	3.250	1.938	2.875	4.500	2.375	#10	7/32	0.375	6.000	2.250	0.068	1.671	0.563
OJUI-□-20TW	1-1/4	1.500	4.000	2.500	3.500	5.500	3.000	#10	7/32	0.438	7.500	2.625	0.068	2.122	0.625
OJUI-□-24TW	1-1/2	1.750	4.750	2.875	4.125	6.500	3.500	1/4	9/32	0.500	9.000	3.000	0.086	2.519	0.750
OJUI-□-32TW	2	2.125	6.000	3.625	5.250	8.250	4.500	3/8	13/32	0.625	10.000	4.000	0.103	3.182	1.000

Supplement the part number with one of the following options.
Example: OJUI-43-08TW for a self-aligning version

- For Standard bearing use **41**
- For Self-aligning bearing use **43**
- For Low clearance use **51**

Technical Data

Part No.	Dynamic Load (lbs)			Static Load (lbs)		
	P = 725 psi			P = 5075 psi		
	0°	90°	180°	0°	90°	180°
OJUI-□-08TW	452	308	160	3170	2156	1110
OJUI-□-10TW	680	462	236	4756	3234	1664
OJUI-□-12TW	816	554	286	5708	3884	1996
OJUI-□-16TW	1180	800	412	8246	5608	2886
OJUI-□-20TW	2378	1618	832	16646	11318	5824
OJUI-□-24TW	3262	2218	1142	22836	15530	7992
OJUI-□-32TW	5800	3944	2030	40600	27608	14208

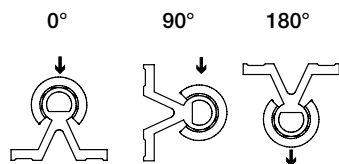

Available with drylin® liners



J200*



E7*



X

- X liner optional for chemicals/high temps up to +482°F (+250°C) for steel housing, up to +356°F (+180°C) for aluminum

drylin® R pillow blocks | Product Range

Square flange, anodized aluminum, pillow block, iglide® J



Order key

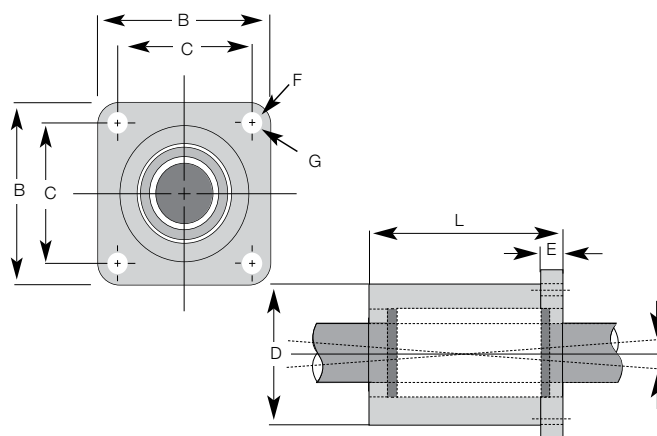

Type	Size
F J U I - XX	-12
Flange	
iglide® J	
Liner	
Inch	
-41 = Standard	
-43 = Self-aligning	
-51 = Low clearance	
Inner Ø d1	

- Low clearance liners optional

Dimensions (inch)

Part No.	Nominal Size	B	C	D	E	F Bolt Size	G	L
FJUI-□-08	1/2	1.63	1.25	1.25	.250	#8	.187	1.687
FJUI-□-12	3/4	2.38	1.75	1.75	.375	#10	.219	2.067
FJUI-□-16	1	2.75	2.125	2.25	.500	1/4	.281	2.812

Part FJUI-41-XX was formerly known as FJUI-11-XX

Supplement the part number with one of the following options.
Example: FJUI-43-12 for a self-aligning version

- For Standard bearing use 41
- For Self-aligning bearing use 43
- For Low clearance use 51

Round flange, anodized aluminum, twin pillow block - iglide® J



- 2x liner JUI-01 made of iglide® J
- More sizes may be available upon request
- Low clearance liners optional

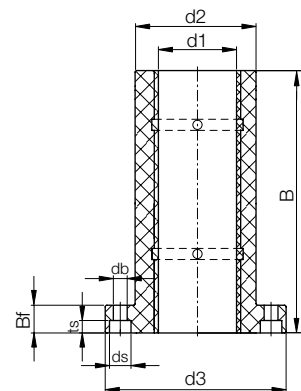
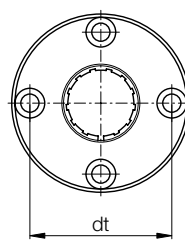

Dimensions (inch)

Part No.	d1	d2	d3	dt	L	Bf	ts	db	ds	Bolt Screw size
FJUIT-01-12	3/4	1.260	2.126	1.693	2.72	.433	.203	.219	.343	#10
FJUIT-01-16	1	1.575	2.441	2.000	3.98	.433	.203	.219	.343	#10

Available with drylin® liners



X

- X liner optional for chemicals/high temps up to +482°F (+250°C) for steel housing, up to +356°F (+180°C) for aluminum

drylin® R pillow blocks | Product Range

Square flange, anodized aluminum, twin pillow block, iglide® J

Order key

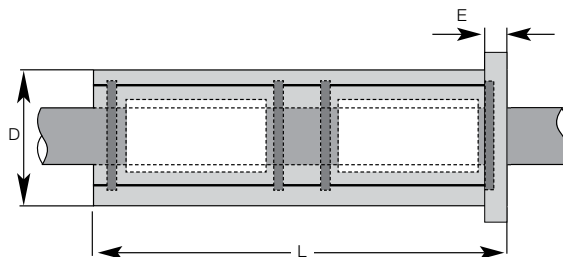
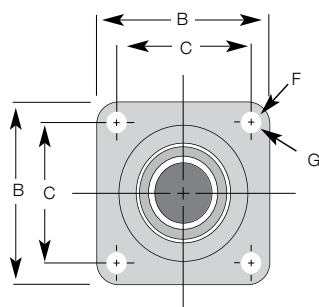

Type				Size	Style
F	J	U	I	-XX	-12 TW
Flange	iglide® J	Liner	Inch	-41 = Standard -43 = Self-aligning -51 = Low clearance	Inner Ø d1 Twin pillow block

Part FJUI-41-XX was formerly known as FJUI-11-XX

- Low clearance liners optional

Dimensions (inch)

Part No.	Nominal Size	B	C	D	E	F Bolt Size	G	L
FJUI-□-08TW	1/2	1.63	1.25	1.25	.250	#8	.187	3.375
FJUI-□-12TW	3/4	2.38	1.75	1.75	.375	#10	.219	4.188
FJUI-□-16TW	1	2.75	2.125	2.25	.500	1/4	.281	5.625

Supplement the part number with one of the following options.
Example: FJUI-43-12TW for a self-aligning version

- For Standard bearing use **41**
- For Self-aligning bearing use **43**
- For Low clearance use **51**

Available with drylin® liners



- X liner optional for chemicals/high temps up to +482°F (+250°C) for steel housing, up to +356°F (+180°C) for aluminum

drylin® R liners | Product Range

Long, closed design for shafts – made from iglide® J

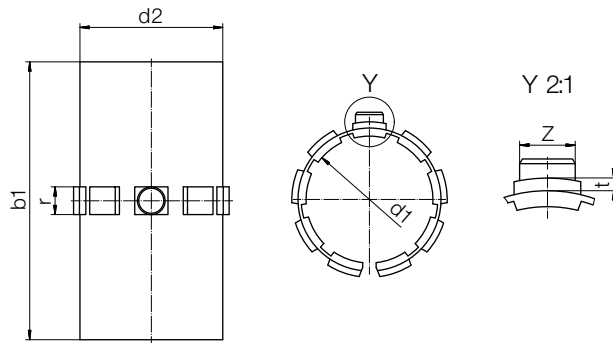

Order key

Type	Size
J U M-01-10	
iglide® J	
Liner	
Metric	
Standard	
Inner Ø d1	

Best Shaft Material: drylin® AWM hard anodized aluminum, case hardened steel, 300 series stainless, 400 series stainless, hard chrome plated steel
Maximum static psi = 5,076 (35MPa)



⁷⁸⁾ According to igus® testing method ► Page 1210
 Please note: Installation instructions ► Page 1212



Min. -58°F (-50°C)
Max. +194°F (+90°C)

Dimensions [mm]

Part No.	d1	d1 tolerance ⁷⁸⁾	d2	b1	r	t	Z	Weight [g]
JUM-01-10	10	+0.030 +0.070	12	28	3.0	0.8	2.5	1.10
JUM-01-12	12	+0.030 +0.070	14	31	3.0	0.8	3.0	1.50
JUM-01-16	16	+0.030 +0.070	18	35	3.5	0.8	3.5	2.20
JUM-01-20	20	+0.030 +0.070	23	44	5.0	0.8	3.5	4.90
JUM-01-25	25	+0.030 +0.070	28	57	5.0	0.8	4.0	8.23
JUM-01-30	30	+0.040 +0.085	34	67	5.0	0.8	4.0	14.95
JUM-01-35	35	+0.040 +0.085	39	69	5.0	0.8	4.0	18.20
JUM-01-40	40	+0.040 +0.085	44	79	6.0	1.3	5.0	23.16
JUM-01-50	50	+0.050 +0.150	55	99	7.0	1.3	6.0	45.35
JUM-01-60 ⁷⁸⁾	60	+0.050 +0.150	65	124	8.0	2.5	6.5	70.00

Installation drawings housing bore for Liner JUM-0

Dimensions [mm]

Part No.	Shaft Ø	d _i H7	B h10	r +0.05	t +0.1	f +0.5	Z +0.2
JUM-01-10	10	12	29	3.0	1.0	1.0	2.6
JUM-01-12	12	14	32	3.0	1.0	1.5	3.1
JUM-01-16	16	18	36	3.5	1.0	1.7	3.6
JUM-01-20	20	23	45	5.0	1.0	2.0	3.6
JUM-01-25	25	28	58	5.0	1.0	2.0	4.1
JUM-01-30	30	34	68	5.0	1.0	2.0	4.1
JUM-01-35	35	39	70	5.0	1.0	2.0	4.1
JUM-01-40	40	44	80	6.0	1.5	2.5	5.1
JUM-01-50	50	55	100	7.0	1.5	2.5	6.1
JUM-01-60 ⁷⁸⁾	60	65	125	8.0	2.5	3.0	6.5

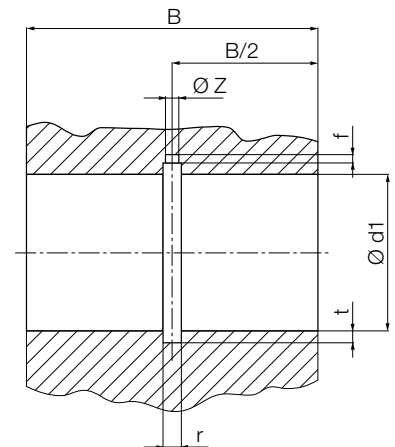

Can be combined with:



RJUM-01/-03
TJUM-01/-03



RJUM-06/-06-LL



FJUM-01/-02

drylin® R liners | Product range

Long, open design for supported shafts – made from iglide® J

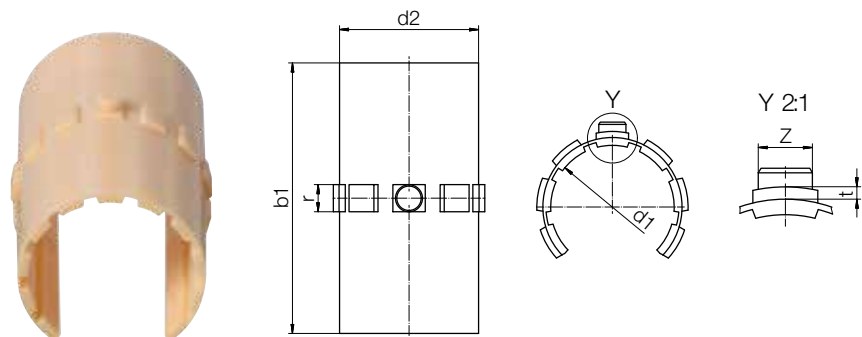

Order key

Type	Size
J U M O - 01 - 10	
iglide® J	
Liner	
Metric	
Open	
Standard	
Inner Ø d1	

Best Shaft Material: drylin® AWM hard anodized aluminum, case hardened steel, 300 series stainless, 400 series stainless, hard chrome plated steel
Maximum static psi = 5,076 (35MPa)

i ⁷⁸⁾ According to igus® testing method ▶ Page 1210
 Please note: Installation instructions ▶ Page 1212
+ Min. -58°F (-50°C)
- Max. +194°F (+90°C)

Dimensions [mm]

Part No.	d1	d1-Tolerance ⁷⁸⁾	d2	b1	r	t	z	Weight [g]
JUMO-01-10	10	+0.030 +0.070	12	28	3.0	0.8	2.5	0.90
JUMO-01-12	12	+0.030 +0.070	14	31	3.0	0.8	3.0	1.16
JUMO-01-16	16	+0.030 +0.070	18	35	3.5	0.8	3.5	1.71
JUMO-01-20	20	+0.030 +0.070	23	44	5.0	0.8	3.5	4.16
JUMO-01-25	25	+0.030 +0.070	28	57	5.0	0.8	4.0	6.97
JUMO-01-30	30	+0.040 +0.085	34	67	5.0	0.8	4.0	12.38
JUMO-01-40	40	+0.040 +0.085	44	79	6.0	1.3	5.0	20.18
JUMO-01-50	50	+0.050 +0.150	55	99	7.0	1.3	6.0	38.60
JUMO-01-60 ⁷⁸⁾	60	+0.050 +0.150	65	124	8.0	2.5	6.5	60.10

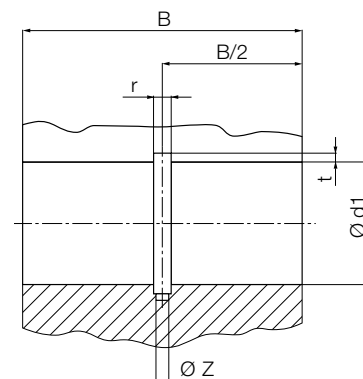

Installation drawings housing bore for Liner JUMO-01

Dimensions [mm]

Part No.	Shaft Ø	di H7	B h10	W +0.2	r +0.05	t +0.1	f +0.5	z +0.2
JUMO-01-10	10	12	29	7.3	3.0	1.0	1.0	2.6
JUMO-01-12	12	14	32	9.0	3.0	1.0	1.5	3.1
JUMO-01-16	16	18	36	11.6	3.5	1.0	1.7	3.6
JUMO-01-20	20	23	45	12.0	5.0	1.0	2.0	3.6
JUMO-01-25	25	28	58	14.5	5.0	1.0	2.0	4.1
JUMO-01-30	30	34	68	16.6	5.0	1.0	2.0	4.1
JUMO-01-40	40	44	80	21.0	6.0	1.5	2.5	5.1
JUMO-01-50	50	55	100	25.5	7.0	1.5	2.5	6.1
JUMO-01-60 ⁷⁸⁾	60	65	125	27.2	8.0	2.5	3.0	6.5

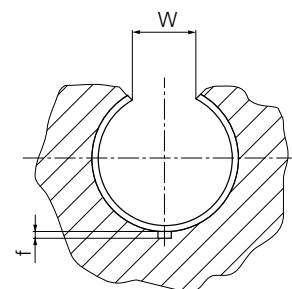

⁷⁸⁾ in two parts

Can be combined with:



OJUM-01/-03



OJUM-06/-06-LL

drylin® R liners | Product Range

Long, closed design, low clearance – iglide® J

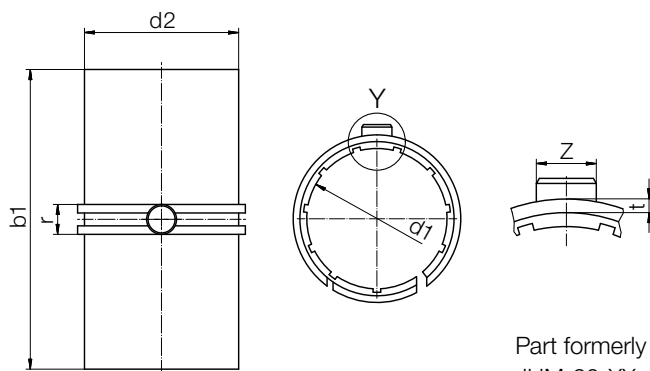

Order key

Type	Size
J U M - 11 - 10	
iglide® J	Liner
Metric	Low-clearance
	Inner Ø d1

Part formerly known as
JUM-20-XX

Best Shaft Material: drylin® AWM hard anodized aluminum, case hardened steel, 300 series stainless, 400 series stainless, hard chrome plated steel
Maximum static psi = 5,076 (35MPa)



™ According to igus® testing method ▶ Page 1210
 Please note: Installation instructions ▶ Page 1212



Min. -58°F (-50°C)
 Max. +194°F (+90°C)

Dimensions [mm]

Part No.	d1	d1-Tolerance™	d2	b1	r	t	z	Weight [g]
JUM-11-10	10	+0.000 +0.040	12	28	3.0	0.8	2.5	1.23
JUM-11-12	12	+0.000 +0.040	14	31	3.0	0.8	3.0	1.65
JUM-11-16	16	+0.000 +0.040	18	35	3.5	0.8	3.5	2.42
JUM-11-20	20	+0.000 +0.040	23	44	5.0	0.8	3.5	5.49
JUM-11-25	25	+0.000 +0.040	28	57	5.0	0.8	4.0	8.86
JUM-11-30	30	+0.000 +0.050	34	67	5.0	0.8	4.0	16.63
JUM-11-40	40	+0.000 +0.050	44	79	6.0	1.3	5.0	26.06
JUM-11-50	50	+0.000 +0.060	55	99	7.0	1.3	6.0	48.82

Installation drawings housing bore for Liner JUM-11

Dimensions [mm]

Part No.	Shaft Ø	di H7	B h10	r +0.05	t +0.1	f +0.5	z +0.2
JUM-11-10	10	12	29	3.0	1.0	1.0	2.6
JUM-11-12	12	14	32	3.0	1.0	1.5	3.1
JUM-11-16	16	18	36	3.5	1.0	1.7	3.6
JUM-11-20	20	23	45	5.0	1.0	2.0	3.6
JUM-11-25	25	28	58	5.0	1.0	2.0	4.1
JUM-11-30	30	34	68	5.0	1.0	2.0	4.1
JUM-11-40	40	44	80	6.0	1.5	2.5	5.1
JUM-11-50	50	55	100	7.0	1.5	2.5	6.1

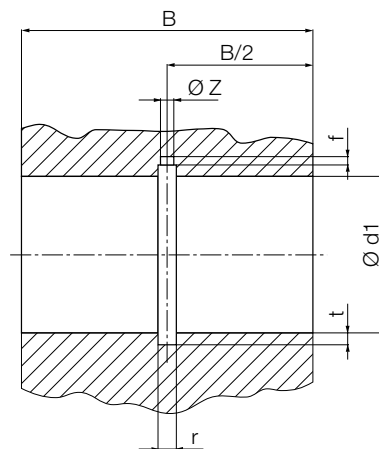

Can be combined with:



RJUM-01/-03
TJUM-01/-03



RJUM-06/-06-LL



FJUM-01/-02

drylin® R liners | Product range

Long, open design, low clearance – iglide® J

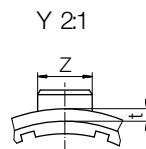
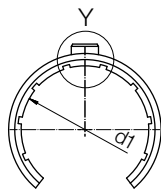
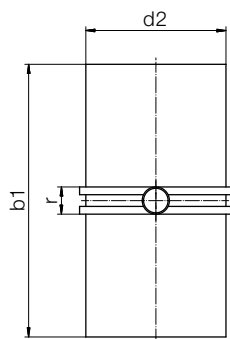

Part formerly known as
JUMO-20-XX



Order key

Type	Size
J U M O - 1 1 - 1 0	
iglide® J	
Liner	
Metric	
Open	
Low-clearance	
Inner Ø d1	

Best Shaft Material: drylin® AWM hard anodized aluminum, case hardened steel, 300 series stainless, 400 series stainless, hard chrome plated steel
Maximum static psi = 5,076 (35MPa)



78) According to igus® testing method ▶ Page 1210
 Please note: Installation instructions ▶ Page 1212



Min. -58°F (-50°C)
 Max. +194°F (+90°C)

Dimensions [mm]

Part No.	d1	d1-Tolerance ⁷⁸⁾	d2	b1	r	t	z	Weight [g]
JUMO-11-10	10	+0.000 +0.040	12	28	3.0	0.8	2.5	1.10
JUMO-11-12	12	+0.000 +0.040	14	31	3.0	0.8	3.0	1.50
JUMO-11-16	16	+0.000 +0.040	18	35	3.5	0.8	3.5	2.20
JUMO-11-20	20	+0.000 +0.040	23	44	5.0	0.8	3.5	4.90
JUMO-11-25	25	+0.000 +0.040	28	57	5.0	0.8	4.0	8.23
JUMO-11-30	30	+0.000 +0.050	34	67	5.0	0.8	4.0	14.95
JUMO-11-40	40	+0.000 +0.050	44	79	6.0	1.3	5.0	23.16
JUMO-11-50	50	+0.000 +0.060	55	99	7.0	1.3	6.0	45.35

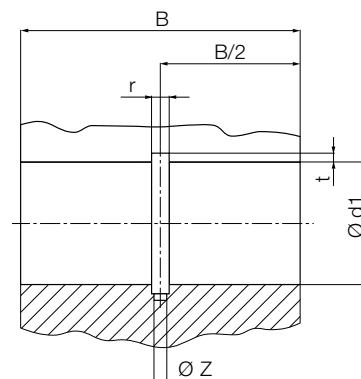

Installation drawings housing bore for Liner JUMO-11

Dimensions [mm]

Part No.	Shaft Ø	d1 H7	B h10	W +0.2	r +0.05	t +0.1	f +0.5	z +0.2
JUMO-11-10	10	12	29	7.3	3.0	1.0	1.0	2.6
JUMO-11-12	12	14	32	9.0	3.0	1.0	1.5	3.1
JUMO-11-16	16	18	36	11.6	3.5	1.0	1.7	3.6
JUMO-11-20	20	23	45	12.0	5.0	1.0	2.0	3.6
JUMO-11-25	25	28	58	14.5	5.0	1.0	2.0	4.1
JUMO-11-30	30	34	68	16.6	5.0	1.0	2.0	4.1
JUMO-11-40	40	44	80	21.0	6.0	1.5	2.5	5.1
JUMO-11-50	50	55	100	25.5	7.0	1.5	2.5	6.1

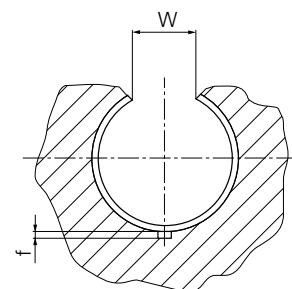

Can be combined with:



OJUM-01/-03



OJUM-06/-06-LL

drylin® R liners | Product Range

Short, closed design – iglide® J

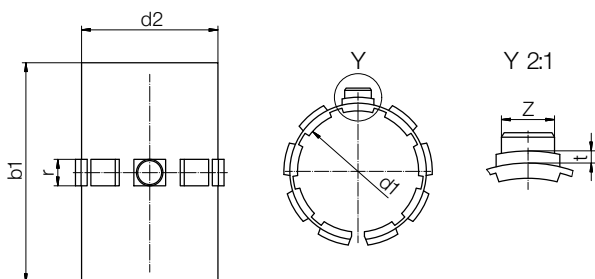

Type	Size
J U M-02-10	
iglide® J	Liner
Metric	Compact
Inner Ø d1	

Best Shaft Material: drylin® AWM hard anodized aluminum, case hardened steel, 300 series stainless, 400 series stainless, hard chrome plated steel
Maximum static psi = 5,076 (35MPa)

i TM According to igus® testing method ▶ Page 1210
 Please note: Installation instructions ▶ Page 1212

+ Min. -58°F (-50°C)
 Max. +194°F (+90°C)

Dimensions [mm]

Part No.	d1	d1-Tolerance TM	d2	b1	r	t	z	Weight [g]
JUM-02-10	10	+0.030 +0.070	12	25	3.0	0.8	2.5	1.02
JUM-02-12	12	+0.030 +0.070	14	27	3.0	0.8	3.0	1.27
JUM-02-16	16	+0.030 +0.070	18	29	3.5	0.8	3.5	1.82
JUM-02-20	20	+0.030 +0.070	23	29	5.0	0.8	3.5	3.27
JUM-02-25	25	+0.030 +0.070	28	39	5.0	0.8	4.0	5.75
JUM-02-30	30	+0.040 +0.085	34	49	5.0	0.8	4.0	11.28
JUM-02-40	40	+0.040 +0.085	44	59	6.0	1.3	5.0	27.00
JUM-02-45	45	+0.040 +0.085	50	59	7.0	1.3	6.0	27.00
JUM-02-50	50	+0.050 +0.150	55	69	7.0	1.3	6.0	32.56

Installation drawings housing bore for Liner JUM-02

Dimensions [mm]

Part No.	Shaft Ø	d _i H7	B h10	r +0.05	t +0.1	f +0.5	z +0.2
JUM-02-10	10	12	26	3.0	1.0	1.0	2.6
JUM-02-12	12	14	28	3.0	1.0	1.5	3.1
JUM-02-16	16	18	30	3.5	1.0	1.7	3.6
JUM-02-20	20	23	30	5.0	1.0	2.0	3.6
JUM-02-25	25	28	40	5.0	1.0	2.0	4.1
JUM-02-30	30	34	50	5.0	1.0	2.0	4.1
JUM-02-40	40	44	60	6.0	1.5	2.5	5.1
JUM-02-45	45	50	60	7.0	1.5	2.5	6.1
JUM-02-50	50	55	70	7.0	1.5	2.5	6.1

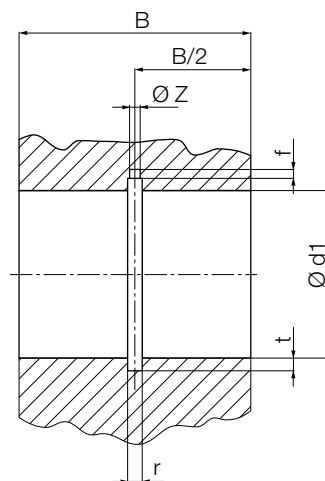

Can be combined with:



RJUM-02



RJUM-05/RJUM-05
TJUM-05/RJUM-05



FJUM-01/-02

drylin® R liners | Product range

Short, closed design, low clearance – iglide® J

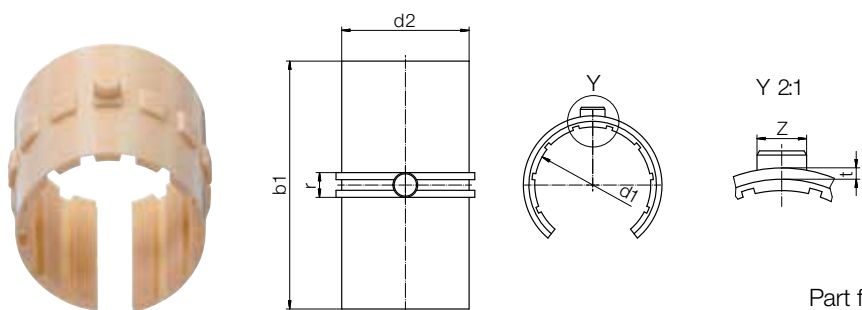
Order key

Type	Size
J U M - 12 - 10	
iglide® J	Liner
Metric	Compact
Inner Ø d1	

 Part formerly known as
JUM-22-XX

Best Shaft Material: drylin® AWM hard anodized aluminum, case hardened steel, 300 series stainless, 400 series stainless, hard chrome plated steel

Maximum static psi = 5,076 (35MPa)



™ According to igus® testing method ▶ Page 1210
Please note: Installation instructions ▶ Page 1212



Min. -58°F (-50°C)
Max. +194°F (+90°C)

Dimensions [mm]

Part No.	d1	d1-Tolerance™	d2	b1	r	t	z	Weight [g]
JUM-12-10	10	+0.000 +0.040	12	25	3.0	0.8	2.5	1.02
JUM-12-12	12	+0.000 +0.040	14	27	3.0	0.8	3.0	1.27
JUM-12-16	16	+0.000 +0.040	18	29	3.5	0.8	3.5	1.82
JUM-12-20	20	+0.000 +0.040	23	29	5.0	0.8	3.5	3.27
JUM-12-25	25	+0.000 +0.040	28	39	5.0	0.8	4.0	5.75
JUM-12-30	30	+0.000 +0.050	34	49	5.0	0.8	4.0	11.28
JUM-12-40	40	+0.000 +0.050	44	59	6.0	1.3	5.0	27.00
JUM-12-45	45	+0.000 +0.060	50	59	7.0	1.3	6.0	27.00
JUM-12-50	50	+0.000 +0.060	55	69	7.0	1.3	6.0	32.56

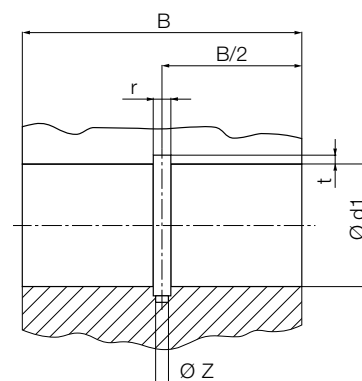

Installation drawings housing bore for Liner JUM-12

Dimensions [mm]

Part No.	Shaft Ø	d1 H7	B h10	r +0.05	t +0.1	f +0.5	z +0.2	z +0.2
JUM-12-10	10	12	26	3.0	1.0	1.0	2.6	2.6
JUM-12-12	12	14	28	3.0	1.0	1.5	3.1	3.1
JUM-12-16	16	18	30	3.5	1.0	1.7	3.6	3.6
JUM-12-20	20	23	30	5.0	1.0	2.0	3.6	3.6
JUM-12-25	25	28	40	5.0	1.0	2.0	4.1	4.1
JUM-12-30	30	34	50	5.0	1.0	2.0	4.1	4.1
JUM-12-40	40	44	60	6.0	1.5	2.5	5.1	5.1
JUM-12-45	45	50	60	7.0	1.5	2.5	6.1	6.1
JUM-12-50	50	55	70	7.0	1.5	2.5	6.1	6.5

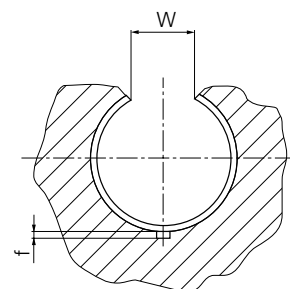

Can be combined with:



RJUM-02

 RJUM-05/RJUM-05
TJUM-05/RJUM-05

FJUMT-01/-02

drylin® R liners | Product Range

Long, closed design for shafts – iglide® J200



Order key

Type	Size
J200 U M-01-10	
iglide® J200	Liner
	Metric
	Standard
	Inner Ø d1

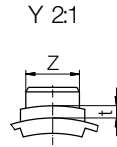
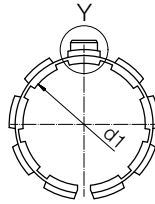
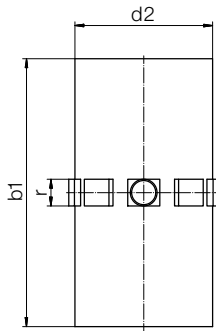

Best Shaft Material: Aluminum
Maximum static psi = 3,336 (23MPa)



⁷⁸ According to igus® testing method ▶ Page 1210
 Please note: Installation instructions ▶ Page 1212



Min. -58°F (-50°C)
 Max. +194°F (+90°C)

Dimensions [mm]

Part No.	d1	d1-Tolerance ⁷⁸	d2	b1	r	t	z	Weight [g]
J200UM-01-10	10	+0.030 +0.070	12	28	3.0	0.8	2.5	1.10
J200UM-01-12	12	+0.030 +0.070	14	31	3.0	0.8	3.0	1.50
J200UM-01-16	16	+0.030 +0.070	18	35	3.5	0.8	3.5	2.20
J200UM-01-20	20	+0.030 +0.070	23	44	5.0	0.8	3.5	4.90
J200UM-01-25	25	+0.030 +0.070	28	57	5.0	0.8	4.0	8.23
J200UM-01-30	30	+0.040 +0.085	34	67	5.0	0.8	4.0	14.95
J200UM-01-35	35	+0.040 +0.085	39	69	5.0	0.8	4.0	18.20
J200UM-01-40	40	+0.040 +0.085	44	79	6.0	1.3	5.0	23.16
J200UM-01-50	50	+0.050 +0.150	55	99	7.0	1.3	6.0	45.35

Installation drawings housing bore for Liner J200UM-01

Dimensions [mm]

Part No.	Shaft Ø	d1 H7	B h10	r +0.05	t +0.1	f +0.5	z +0.2
J200UM-01-10	10	12	29	3.0	1.0	1.0	2.6
J200UM-01-12	12	14	32	3.0	1.0	1.5	3.1
J200UM-01-16	16	18	36	3.5	1.0	1.7	3.6
J200UM-01-20	20	23	45	5.0	1.0	2.0	3.6
J200UM-01-25	25	28	58	5.0	1.0	2.0	4.1
J200UM-01-30	30	34	68	5.0	1.0	2.0	4.1
J200UM-01-35	35	39	70	5.0	1.0	2.0	4.1
J200UM-01-40	40	44	80	6.0	1.5	2.5	5.1
J200UM-01-50	50	55	100	7.0	1.5	2.5	6.1

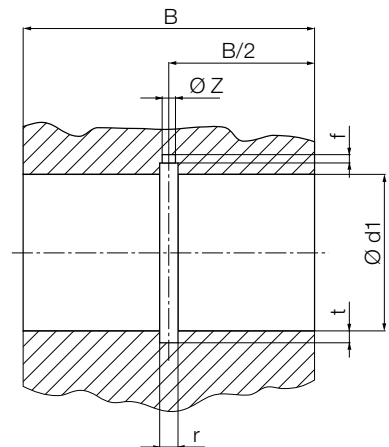

Can be combined with:



RJUM-01/-03
TJUM-01/-03



RJUM-06/-06-LL



FJUM-01/-02

drylin® R liners | Product range

Long, open design for shafts – iglide® J200

Order key

Type	Size
J200 U M O -01 -10	
iglide® J200	Liner
	Metric
	Open
	Standard
	Inner Ø d1

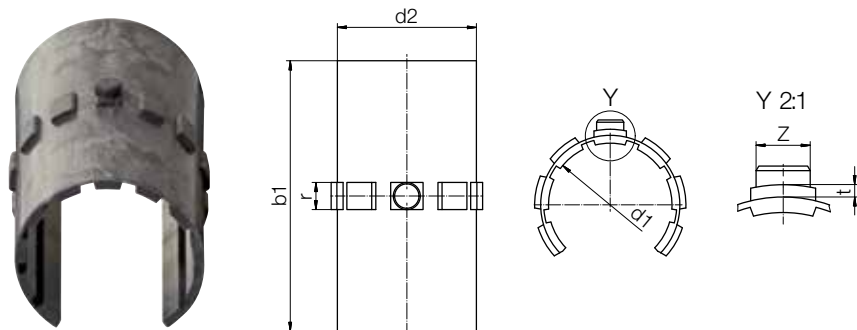

Best Shaft Material: Aluminum
Maximum static psi = 3,336 (23MPa)

Min. -58°F (-50°C)
 Max. +194°F (+90°C)

i ⁷⁸⁾ According to igus® testing method ▶ Page 1210
 Please note: Installation instructions ▶ Page 1212

Dimensions [mm]

Part No.	d1	d1-Tolerance ⁷⁸⁾	d2	b1	r	t	z	Weight [g]
J200UMO-01-10	10	+0.030 +0.070	12	28	3.0	0.8	2.5	0.90
J200UMO-01-12	12	+0.030 +0.070	14	31	3.0	0.8	3.0	1.16
J200UMO-01-16	16	+0.030 +0.070	18	35	3.5	0.8	3.5	1.71
J200UMO-01-20	20	+0.030 +0.070	23	44	5.0	0.8	3.5	4.16
J200UMO-01-25	25	+0.030 +0.070	28	57	5.0	0.8	4.0	6.97
J200UMO-01-30	30	+0.040 +0.085	34	67	5.0	0.8	4.0	12.38
J200UMO-01-40	40	+0.040 +0.085	44	79	6.0	1.3	5.0	20.18
J200UMO-01-50	50	+0.050 +0.150	55	99	7.0	1.3	6.0	38.60

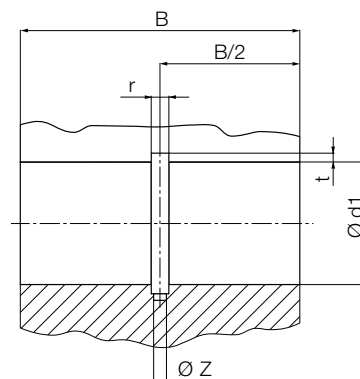

Installation drawings housing bore for Liner J200UMO-01

Dimensions [mm]

Part No.	Shaft Ø	d _i H7	B h10	W +0.2	r +0.05	t +0.1	f +0.5	z +0.2
J200UMO-01-10	10	12	29	7.3	3.0	1.0	1.0	2.6
J200UMO-01-12	12	14	32	9.0	3.0	1.0	1.5	3.1
J200UMO-01-16	16	18	36	11.6	3.5	1.0	1.7	3.6
J200UMO-01-20	20	23	45	12.0	5.0	1.0	2.0	3.6
J200UMO-01-25	25	28	58	14.5	5.0	1.0	2.0	4.1
J200UMO-01-30	30	34	68	16.6	5.0	1.0	2.0	4.1
J200UMO-01-40	40	44	80	21.0	6.0	1.5	2.5	5.1
J200UMO-01-50	50	55	100	25.5	7.0	1.5	2.5	6.1

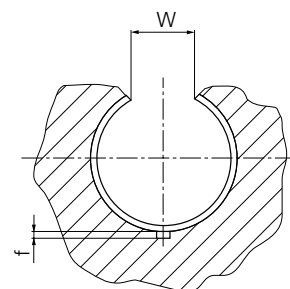

Can be combined with:



OJUM-01/-03



OJUM-06/-06-LL



FJUM-01/-02

drylin® R liners | Product Range

Long, closed design for steel/stainless steel shafts – iglide® E7

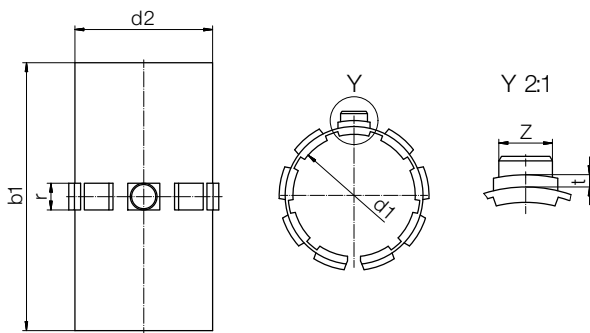

Order key

Type	Size
E7	U M-01-10
iglide® E7	Liner
	Metric
	Standard
	Inner Ø d1

Best Shaft Material: steel and stainless shafting
Maximum static psi = 2,611 (18MPa)



Min. -58°F (-50°C)
 Max. +158°F (+70°C)



⁷⁸⁾ According to igus® testing method ► Page 1210
 Please note: Installation instructions ► Page 1212

Dimensions [mm]

Part No.	d1	d1-Tolerance ⁷⁸⁾	d2	b1	r	t	z	Weight [g]
E7UM-01-10	10	+0.030 +0.070	12	28	3.0	0.8	2.5	0.73
E7UM-01-12	12	+0.030 +0.070	14	31	3.0	0.8	3.0	1.01
E7UM-01-16	16	+0.030 +0.070	18	35	3.5	0.8	3.5	1.45
E7UM-01-20	20	+0.030 +0.070	23	44	5.0	0.8	3.5	3.25
E7UM-01-25	25	+0.030 +0.070	28	57	5.0	0.8	4.0	5.44
E7UM-01-30	30	+0.040 +0.085	34	67	5.0	0.8	4.0	9.88
E7UM-01-40	40	+0.040 +0.085	44	79	6.0	1.3	5.0	17.3
*E7UM-01-50	50	+0.050 +0.150	55	99	7.0	1.3	6.0	-
*E7UM-01-60 ⁷⁸⁾	60	+0.050 +0.150	65	124	8.0	2.5	6.5	-

Installation drawings housing bore for Liner E7UM-01

Dimensions [mm]

Part No.	Shaft Ø	di H7	B h10	r +0.05	t +0.1	f +0.5	z +0.2
E7UM-01-10	10	12	29	3.0	1.0	1.0	2.6
E7UM-01-12	12	14	32	3.0	1.0	1.5	3.1
E7UM-01-16	16	18	36	3.5	1.0	1.7	3.6
E7UM-01-20	20	23	45	5.0	1.0	2.0	3.6
E7UM-01-25	25	28	58	5.0	1.0	2.0	4.1
E7UM-01-30	30	34	68	5.0	1.0	2.0	4.1
E7UM-01-40	40	44	80	6.0	1.5	2.5	5.1
*E7UM-01-50	50	55	100	7.0	1.5	2.5	6.1
*E7UM-01-60 ⁷⁸⁾	60	65	125	8.0	2.5	3.0	6.5

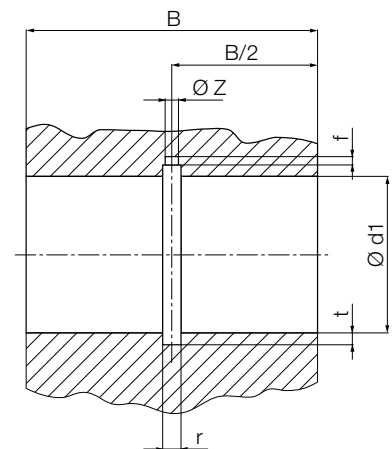

*two-piece liners

Can be combined with:



RJUM-01/-03
 TJUM-01/-03



RJUM-06/-06-LL



FJUM-01/-02

drylin® R liners | Product range

Long, open design for steel/stainless steel shafts – iglide® E7



Order key

Type	Size
E7 U M O -01 -10	
iglide® E7	Liner
	Metric
	Open
	Standard
	Inner Ø d1

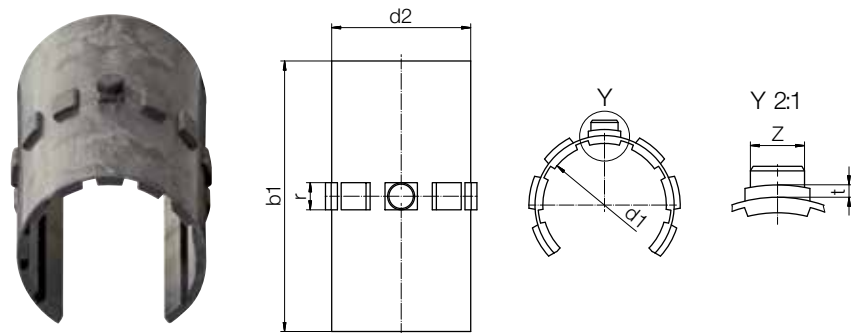

Best Shaft Material: steel/stainless steel
Maximum static psi = 2,611 (18MPa)



Min. -58°F (-50°C)
 Max. +158°F (+70°C)



⁷⁸⁾ According to igus® testing method ▶ Page 1210
 Please note: Installation instructions ▶ Page 1212

Dimensions [mm]

Part No.	d1	d1-Tolerance ⁷⁸⁾	d2	b1	r	t	z	Weight [g]
E7UMO-01-10	10	+0.030 +0.070	12	28	3.0	0.8	2.5	0.90
E7UMO-01-12	12	+0.030 +0.070	14	31	3.0	0.8	3.0	1.16
E7UMO-01-16	16	+0.030 +0.070	18	35	3.5	0.8	3.5	1.71
E7UMO-01-20	20	+0.030 +0.070	23	44	5.0	0.8	3.5	4.16
E7UMO-01-25	25	+0.030 +0.070	28	57	5.0	0.8	4.0	6.97
E7UMO-01-30	30	+0.040 +0.085	34	67	5.0	0.8	4.0	12.38
E7UMO-01-40	40	+0.040 +0.085	44	79	6.0	1.3	5.0	20.18
*E7UMO-01-50	50	+0.050 +0.150	55	99	7.0	1.3	6.0	38.60
*E7UMO-01-60 ⁷⁸⁾	60	+0.050 +0.150	65	124	8.0	2.5	6.5	60.10

Installation drawings housing bore for Liner E7UMO-01

Dimensions [mm]

Part No.	Shaft Ø	di H7	B h10	W +0.2	r +0.05	t +0.1	f +0.5	z +0.2
E7UMO-01-10	10	12	29	7.3	3.0	1.0	1.0	2.6
E7UMO-01-12	12	14	32	9.0	3.0	1.0	1.5	3.1
E7UMO-01-16	16	18	36	11.6	3.5	1.0	1.7	3.6
E7UMO-01-20	20	23	45	12.0	5.0	1.0	2.0	3.6
E7UMO-01-25	25	28	58	14.5	5.0	1.0	2.0	4.1
E7UMO-01-30	30	34	68	16.6	5.0	1.0	2.0	4.1
E7UMO-01-40	40	44	80	21.0	6.0	1.5	2.5	5.1
*E7UMO-01-50	50	55	100	25.5	7.0	1.5	2.5	6.1
*E7UMO-01-60 ⁷⁸⁾	60	65	125	27.2	8.0	2.5	3.0	6.5

*two-piece liners

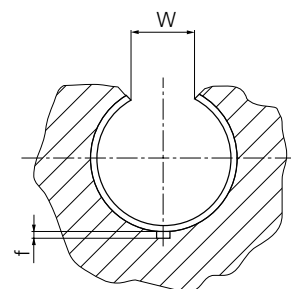
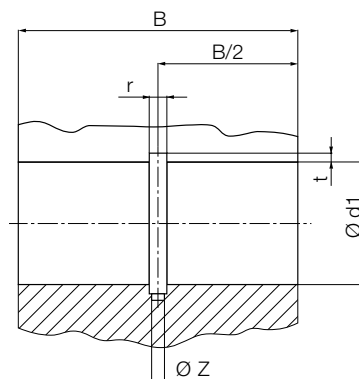

Can be combined with:



OJUM-01/-03



OJUM-06/-06-LL

drylin® R liners | Product Range

Short, closed design – iglide® E7

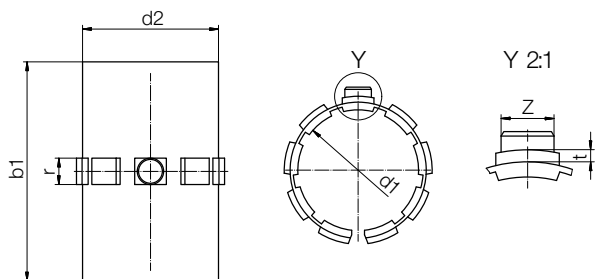

Type	Size
E7	U M-02-10
iglide® E7	Liner
Metric	Compact
Inner Ø d1	

Compact design

Best Shaft Material: steel and stainless shafting

Maximum static psi = 2,611 (18MPa)



⁷⁸⁾ According to igus® testing method ▶ Page 1210
Please note: Installation instructions ▶ Page 1212



Min. -58°F (-50°C)
Max. +158°F (+70°C)

Dimensions [mm]

Part No.	d1	d1 tolerance ⁷⁸⁾	d2	b1	r	t	Z	Weight [g]
E7UM-02-10	10	+0.030 +0.070	12	25	3.0	0.8	2.5	0.73
E7UM-02-12	12	+0.030 +0.070	14	27	3.0	0.8	3.0	1.01
E7UM-02-16	16	+0.030 +0.070	18	29	3.5	0.8	3.5	1.45
E7UM-02-20	20	+0.030 +0.070	23	29	5.0	0.8	3.5	3.25
E7UM-02-25	25	+0.030 +0.070	28	39	5.0	0.8	4.0	5.44
E7UM-02-30	30	+0.040 +0.085	34	49	5.0	0.8	4.0	9.88
E7UM-02-40	40	+0.040 +0.085	44	59	6.0	1.3	5.0	17.30

Housing hole for E7UM-02

Dimensions [mm]

Part No.	Shaft Ø	d _i H7	B h10	r +0.05	t +0.1	f +0.5	Z +0.2
E7UM-02-10	10	12	26	3.0	1.0	1.0	2.6
E7UM-02-12	12	14	28	3.0	1.0	1.5	3.1
E7UM-02-16	16	18	30	3.5	1.0	1.7	3.6
E7UM-02-20	20	23	30	5.0	1.0	2.0	3.6
E7UM-02-25	25	28	40	5.0	1.0	2.0	4.1
E7UM-02-30	30	34	50	5.0	1.0	2.0	4.1
E7UM-02-40	40	44	60	6.0	1.5	2.5	5.1

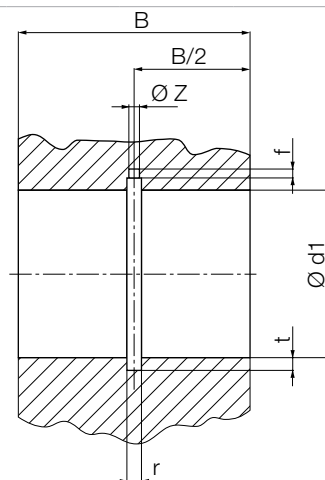

Can be combined with:



RJUM-02



RJUM-05/RJUM-05
TJUM-05/RJUM-05



FJUMT-01/-02

drylin® R liners | Product range

Long, closed design, two-piece, high temperature – iglide® X



Order key

Type	Size
X U M-01-10	
iglide® X	
Liner	
Metric	
Standard	
Inner Ø d1	

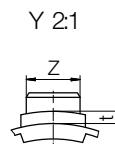
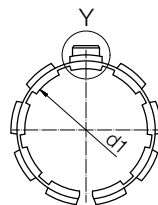
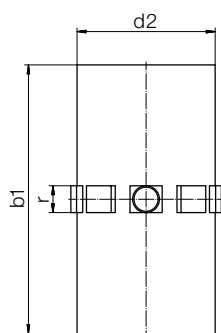
**Material:** iglide® X**Temp. range:** -148°F to +482°F in steel housing, up to 356°F in aluminum adapter**Best Shaft Material:** Hardened stainless and hard chrome plated steel.**Maximum static psi** = 21,760 (150MPa)⁷⁸⁾ According to igus® testing method ▶ Page 1210

Please note: Installation instructions ▶ Page 1212



Min. -148°F (-100°C)

Max. +482°F (+250°C)

Dimensions [mm]

Part No.	d1	d1-Tolerance ⁷⁸⁾	d2	b1	r	t	z	Weight [g]
XUM-01-12	12	+0.030 +0.070	14	31	3.0	0.8	3.0	1.46
XUM-01-14	14	+0.030 +0.070	16	30	3.5	0.6	3.5	1.81
XUM-01-16	16	+0.030 +0.070	18	35	3.5	0.8	3.5	2.13
XUM-01-20	20	+0.030 +0.070	23	44	5.0	0.8	3.5	4.7
XUM-01-25	25	+0.030 +0.070	28	57	5.0	0.8	4.0	8.27
XUM-01-30	30	+0.040 +0.085	34	67	5.0	0.8	4.0	15.57
XUM-01-40	40	+0.040 +0.085	44	79	6.0	1.3	5.0	24.0

Installation drawings housing bore for Liner XUM-01

Dimensions [mm]

Part No.	Shaft Ø	d _i H7	B h10	r +0.05	t +0.1	f +0.5	z +0.2
XUM-01-12	12	14	32	3.0	1.0	1.5	3.1
XUM-01-14	14	16	31	3.5	0.8	1.7	3.6
XUM-01-16	16	18	36	3.5	1.0	1.7	3.6
XUM-01-20	20	23	45	5.0	1.0	2.0	3.6
XUM-01-25	25	28	58	5.0	1.0	2.0	4.1
XUM-01-30	30	34	68	5.0	1.0	2.0	4.1
XUM-01-40	40	44	80	6.0	1.5	2.5	5.1

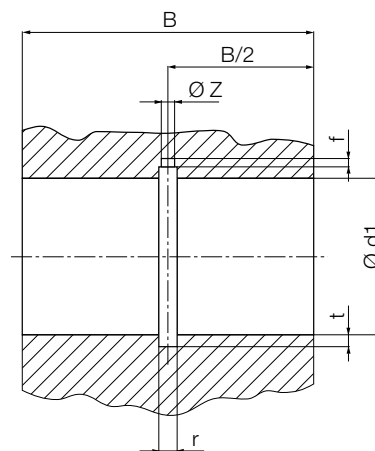

Can be combined with:

RJUM-01/-03
TJUM-01/-03

RJUM-06/-06-LL



FJUM-01/-02

drylin® R liners | Product Range

Long, open design, two-piece, high temperature – iglide® X

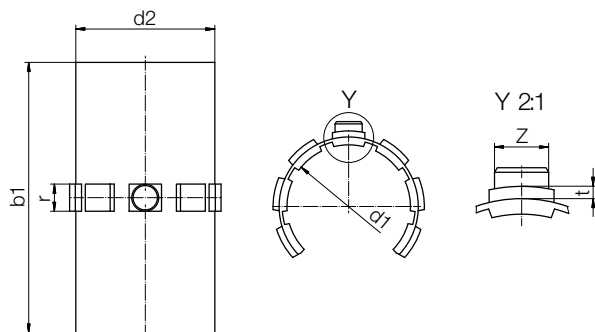

Order key

Type	Size
X U M O -01 -10	
iglide® X	
Liner	
Metric	
Open	
Standard	
Inner Ø d1	

Material: iglide® X

Temp. range: -148°F to +482°F in steel housing, up to 356°F in aluminum adapter

Best Shaft Material: Hardened stainless and hard chrome plated steel.

Maximum static psi = 21,760 (150MPa)



⁷⁸⁾ According to igus® testing method ▶ Page 1210
Please note: Installation instructions ▶ Page 1212



Min. -148°F (-100°C)
Max. +482°F (+250°C)

Dimensions [mm]

Part No.	d1	d1-Tolerance™	d2	b1	r	t	z	Weight [g]
XUMO-01-10 ¹¹⁰⁾	10	+0.000 +0.020	12	28	3.0	0.8	2.5	1.0
XUMO-01-12	12	+0.030 +0.070	14	31	3.0	0.8	3.0	1.46
XUMO-01-16	16	+0.030 +0.070	18	35	3.5	0.8	3.5	2.13
XUMO-01-20	20	+0.030 +0.070	23	44	5.0	0.8	3.5	4.7
XUMO-01-25	25	+0.030 +0.070	28	57	5.0	0.8	4.0	8.27
XUMO-01-30	30	+0.040 +0.085	34	67	5.0	0.8	4.0	15.57
XUMO-01-40	40	+0.040 +0.085	44	79	6.0	1.3	5.0	24.0

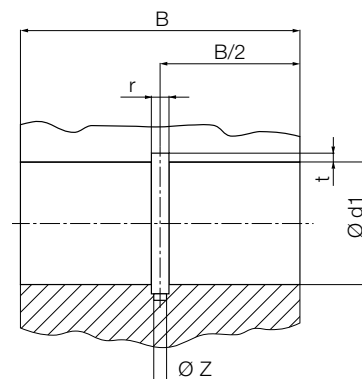

Installation drawings housing bore for XUMO-01

Dimensions [mm]

Part No.	Shaft Ø	d1 H7	B h10	W +0.2	r +0.05	t +0.1	f +0.5	z +0.2
XUMO-01-10 ¹¹⁰⁾	10	12	29	7.3	3.0	1.0	1.0	2.6
XUMO-01-12	12	14	32	9.0	3.0	1.0	1.5	3.1
XUMO-01-16	16	18	36	11.6	3.5	1.0	1.7	3.6
XUMO-01-20	20	23	45	12.0	5.0	1.0	2.0	3.6
XUMO-01-25	25	28	58	14.5	5.0	1.0	2.0	4.1
XUMO-01-30	30	34	68	16.6	5.0	1.0	2.0	4.1
XUMO-01-40	40	44	80	21.0	6.0	1.5	2.5	5.1

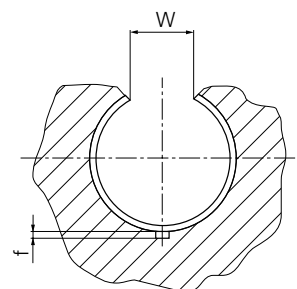

¹¹⁰⁾ One piece

Can be combined with:



OJUM-01/-03



OJUM-06/-06-LL

drylin® R liners | Product range

Short, closed design, two-piece, high temperature – iglide® X

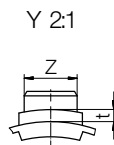
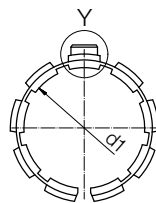
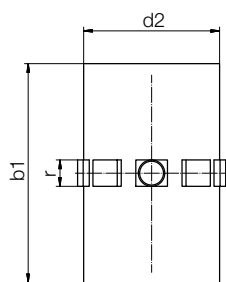

Order key

Type	Size
X U M -02-10	
iglide® X	Liner
Metric	Compact
	Inner Ø d1

Material: iglide® X**Temp. range:** -148°F to +482°F in steel housing, up to 356°F in aluminum adapter**Best Shaft Material:** Hardened stainless and hard chrome plated steel.**Maximum static psi** = 21,760 (150MPa)

™ According to igus® testing method ▶ Page 1210
Please note: Installation instructions ▶ Page 1212



Min. -148°F (-100°C)
Max. +482°F (+250°C)

Dimensions [mm]

Part No.	d1	d1-Tolerance™	d2	b1	r	t	z	Weight [g]
XUM-02-12	12	+0.030 +0.070	14	27	3.0	0.8	3.0	1.46
XUM-02-16	16	+0.030 +0.070	18	29	3.5	0.8	3.5	2.13
XUM-02-20	20	+0.030 +0.070	23	29	5.0	0.8	3.5	4.7
XUM-02-25	25	+0.030 +0.070	28	39	5.0	0.8	4.0	8.27
XUM-02-30	30	+0.040 +0.085	34	49	5.0	0.8	4.0	15.57
XUM-02-40	40	+0.040 +0.085	44	59	6.0	1.3	5.0	24.0
XUM-01-40	40	+0.040 +0.085	44	79	6.0	1.3	5.0	24.0

Installation drawings housing bore for Liner XUM-02

Dimensions [mm]

Part No.	Shaft Ø	d _i H7	B h10	r +0.05	t +0.1	f +0.5	z +0.2
XUM-02-12	12	14	28	3.0	1.0	1.5	3.1
XUM-02-16	16	18	30	3.5	1.0	1.7	3.6
XUM-02-20	20	23	30	5.0	1.0	2.0	3.6
XUM-02-25	25	28	40	5.0	1.0	2.0	4.1
XUM-02-30	30	34	50	5.0	1.0	2.0	4.1
XUM-02-40	40	44	60	6.0	1.5	2.5	5.1
XUM-01-40	40	44	80	6.0	1.5	2.5	5.1

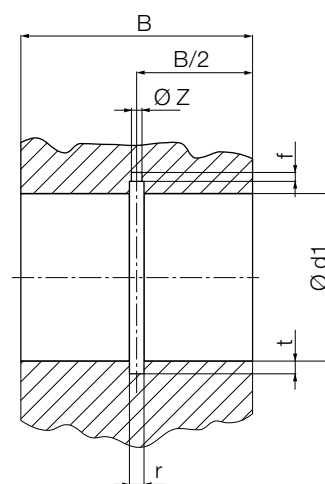

Can be combined with:



RJUM-02



RJUM-01-ES

RJUM-05/RJUME-05
TJUM-05/RJUMT-05

FJUMT-01/-02

drylin® R liners | Product Range

Long, closed design, FDA compliant – iglide® A180

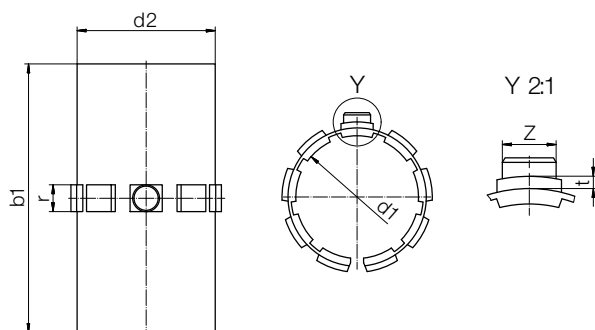

Order key

Type	Size
A180 U M-01-10	
iglide® A160	Liner
Metric	Standard
	Inner Ø d1

Material: iglide® A180

Best Shaft Material: Stainless steel

Maximum static psi = 4,061 (28MPa)



⁷⁸⁾ According to igus® testing method ▶ Page 1210
Please note: Installation instructions ▶ Page 1212



Min. -58°F (-50°C)
Max. +194°F (+90°C)

Dimensions [mm]

Part No.	d1	d1 tolerance ⁷⁸⁾	d2	b1	r	t	Z	Weight [g]
A180UM-01-10	10	+0.000 +0.020	12	28	3.0	0.8	2.5	1.08
A180UM-01-12	12	+0.030 +0.070	14	31	3.0	0.8	3.0	1.47
A180UM-01-16	16	+0.030 +0.070	18	35	3.5	0.8	3.5	2.16
A180UM-01-20	20	+0.030 +0.070	23	44	5.0	0.8	3.5	4.80
A180UM-01-25	25	+0.030 +0.070	28	57	5.0	0.8	4.0	8.07
A180UM-01-30	30	+0.040 +0.085	34	67	5.0	0.8	4.0	14.65
A180UM-01-35	35	+0.040 +0.085	39	69	5.0	0.8	4.0	17.84
A180UM-01-40	40	+0.040 +0.085	44	79	6.0	1.3	5.0	22.70
A180UM-01-50	50	+0.050 +0.150	55	99	7.0	1.3	6.0	44.44

Installation drawings housing bore for A180UM-01

Dimensions [mm]

Part No.	Shaft Ø	d1 H7	B h10	r +0.05	t +0.1	f +0.5	Z +0.2
A180UM-01-10	10	12	29	3.0	1.0	1.0	2.6
A180UM-01-12	12	14	32	3.0	1.0	1.5	3.1
A180UM-01-16	16	18	36	3.5	1.0	1.7	3.6
A180UM-01-20	20	23	45	5.0	1.0	2.0	3.6
A180UM-01-25	25	28	58	5.0	1.0	2.0	4.1
A180UM-01-30	30	34	68	5.0	1.0	2.0	4.1
A180UM-01-35	35	39	70	5.0	1.0	2.0	4.1
A180UM-01-40	40	44	80	6.0	1.5	2.5	5.1
A180UM-01-50	50	55	100	7.0	1.5	2.5	6.1

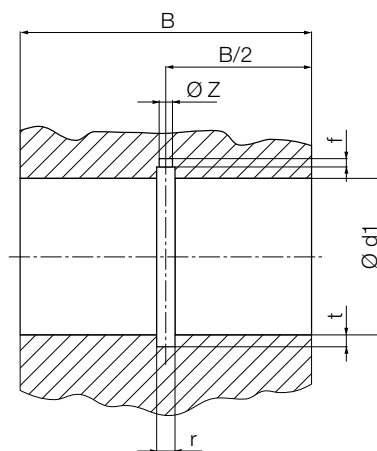

Can be combined with:



RJUM-01/-03
TJUM-01/-03



RJUM-06/-06-LL



FJUM-01/-02

drylin® R liners | Product range

Long, open design, FDA compliant – iglide® A180

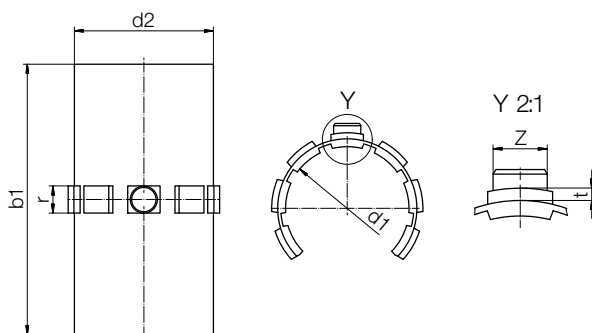

Order key

Type	Size
A180 U M O -01 -10	
iglide® A160	Inner Ø d1
Liner	Standard
Metric	Open

Material: iglide® A180

Best Shaft Material: Stainless steel

Maximum static psi = 4,061 (28MPa)



™ According to igus® testing method ▶ Page 1210
Please note: Installation instructions ▶ Page 1212



Min. -58°F (-50°C)
Max. +194°F (+90°C)

Dimensions [mm]

Part No.	d1	d1 tolerance [™]	d2	b1	r	t	Z	Weight [g]
A180UMO-01-10	10	+0.000 +0.020	12	28	3.0	0.8	2.5	1.08
A180UMO-01-12	12	+0.030 +0.070	14	31	3.0	0.8	3.0	1.47
A180UMO-01-16	16	+0.030 +0.070	18	35	3.5	0.8	3.5	2.16
A180UMO-01-20	20	+0.030 +0.070	23	44	5.0	0.8	3.5	4.80
A180UMO-01-25	25	+0.030 +0.070	28	57	5.0	0.8	4.0	8.07
A180UMO-01-30	30	+0.040 +0.085	34	67	5.0	0.8	4.0	14.65
A180UMO-01-40	35	+0.040 +0.085	39	69	5.0	0.8	4.0	17.84
A180UMO-01-50	40	+0.040 +0.085	44	79	6.0	1.3	5.0	22.70

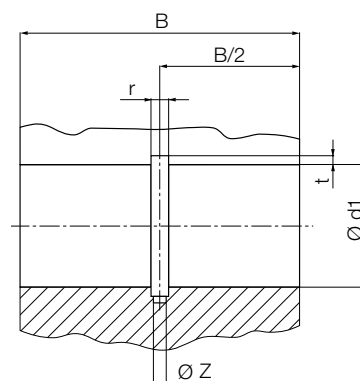

Installation drawings housing bore for Liner A180UMO-01

Dimensions [mm]

Part No.	Shaft Ø	d1 H7	B h10	W +0.5	r +0.05	t +0.1	f +0.2	Z
A180UMO-01-10	10	12	29	7.3	3.0	1.0	1.0	2.6
A180UMO-01-12	12	14	32	9.0	3.0	1.0	1.5	3.1
A180UMO-01-16	16	18	36	11.6	3.5	1.0	1.7	3.6
A180UMO-01-20	20	23	45	12.0	5.0	1.0	2.0	3.6
A180UMO-01-25	25	28	58	14.5	5.0	1.0	2.0	4.1
A180UMO-01-30	30	34	68	16.6	5.0	1.0	2.0	4.1
A180UMO-01-40	40	44	80	21.0	6.0	1.5	2.5	5.1
A180UMO-01-50	50	55	100	25.5	7.0	1.5	2.5	6.1

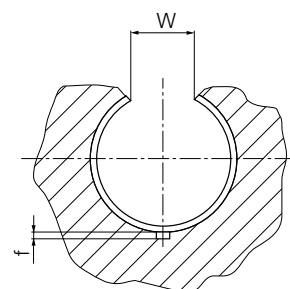

Can be combined with:



OJUM-01/-03
TJUM-01/-03



OJUM-06/-06-LL

drylin® R liners | Product Range

Long, closed design, FDA / EU 10/2011 compliant – iglide® A160

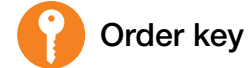
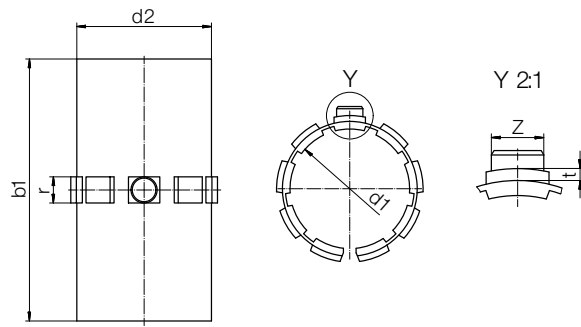

Order key

Type		Size		
A160 U M-01-10				
iglide® A160	Liner	Metric	Standard	Inner Ø d1

Compliant with Regulation (EU) No. 10/2011 and FDA guidelines for longer service life on hardened stainless steel shafts



Min. -58°F (-50°C)
Max. +194°F (+90°C)



⁷⁸⁾ According to igus® testing method ► Page 1210
Please note: Installation instructions ► Page 1212

Dimensions [mm]

Part No.	d1	d1 tolerance ⁷⁸⁾	d2	b1	r	t	Z	Weight [g]
A160UM-01-10	10	+0.030 +0.070	12	28	3.0	0.8	2.5	0.7
A160UM-01-12	12	+0.030 +0.070	14	31	3.0	0.8	3.0	1.0
A160UM-01-16	16	+0.030 +0.070	18	35	3.5	0.8	3.5	1.5
A160UM-01-20	20	+0.030 +0.070	23	44	5.0	0.8	3.5	3.3
A160UM-01-25	25	+0.030 +0.070	28	57	5.0	0.8	4.0	5.4
A160UM-01-30	30	+0.040 +0.090	34	67	5.0	0.8	4.0	9.9
A160UM-01-40	40	+0.040 +0.090	44	79	6.0	1.3	5.0	17.3
A160UM-01-50	50	+0.005 +0.150	55	99	7.0	1.3	6.0	36.3

Housing hole for A160UM-01 | Dimensions [mm]

Part No.	Shaft Ø	d1 H7	B h10	r +0.05	t +0.1	f +0.5	Z +0.2
A160UM-01-10	10	12	29	3.0	1.0	1.0	2.6
A160UM-01-12	12	14	32	3.0	1.0	1.5	3.1
A160UM-01-16	16	18	36	3.5	1.0	1.7	3.6
A160UM-01-20	20	23	45	5.0	1.0	2.0	3.6
A160UM-01-25	25	28	58	5.0	1.0	2.0	4.1
A160UM-01-30	30	34	68	5.0	1.0	2.0	4.1
A160UM-01-35	35	39	70	5.0	1.0	2.0	4.1
A160UM-01-40	40	44	80	6.0	1.5	2.5	5.1
A160UM-01-50	50	55	100	7.0	1.5	2.5	6.1

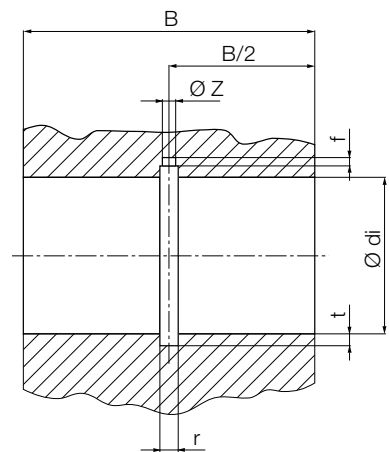

Can be combined with:



RJUM-01/-03
TJUM-01/-03



RJUM-06/-06-LL



FJUM-01/-02

Notes

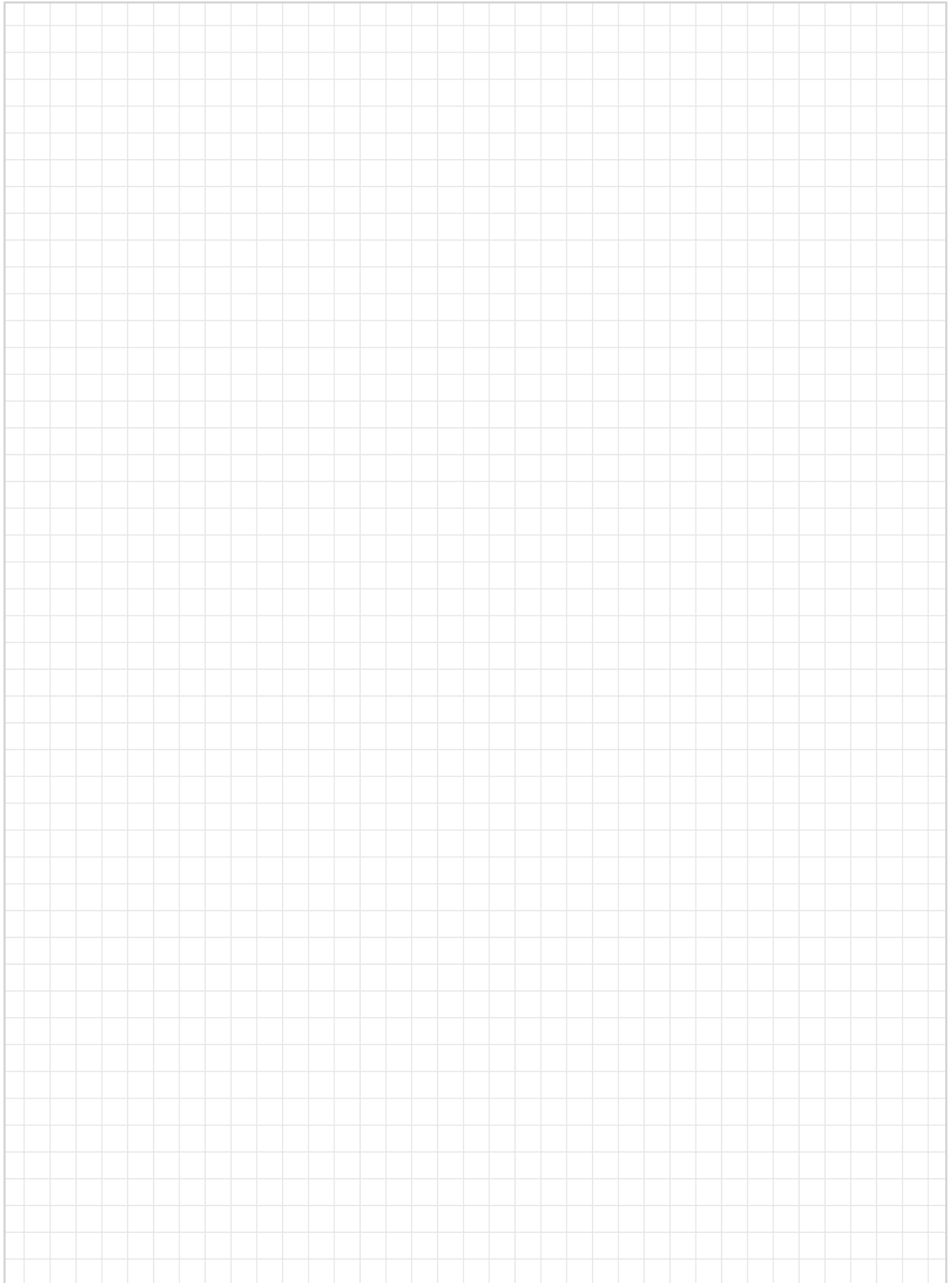

drylin® R clip-in | Product Range

Clip-on liners – iglide® J

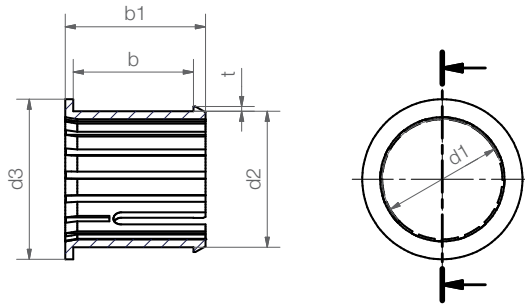

Order key

Type	Size
J U C M - 12 16 - 16	
iglide® J	Inner Ø d1
Liner	Outer Ø d2
Clip-on	Length b
Metric	

- Quick installation by hand for sheet thicknesses of 12 to 30mm



⁷⁸⁾ According to igus® testing method ► Page 1210

⁸²⁾ Design standards ► Page 1209

Please note: Installation instructions ► Page 1212



Min. -58°F (-50°C)

Max. +194°F (+90°C)

Dimensions [mm]

Part No	d1	d2	d3	b	b1	t
				+0.05 / +0.25		
JUCM-1216-16	12	16	20	16	20.5	0.8
JUCM-1418-18	14	18	22	18	22.5	0.8
JUCM-1620-20	16	20	25	20	24.5	0.8
JUCM-1822-20	18	22	26	20	24.5	0.8
JUCM-2024-25	20	24	30	25	30.0	1.0
JUCM-2227-27	22	27	34	27	32	1.0
JUCM-2227-34	22	27	32	34	39.5	1.0
JUCM-2529-30	25	29	35	30	35.5	1.0
JUCM-3034-30	30	34	40	30	35.0	1.2

Technical data

Part No	d1 tolerance ⁷⁸⁾	Fmax. dynamic ⁸²⁾	Fmax. static ⁸²⁾	Weight
		p = 5MPa	p = 35MPa	
	[mm]	[N]	[N]	[g]
JUCM-1216-16	+0.04 +0.10	320	1,600	2.5
JUCM-1418-18	+0.04 +0.10	440	2,200	2.9
JUCM-1620-20	+0.04 +0.10	560	2,800	3.9
JUCM-1822-20	+0.04 +0.10	630	3,150	4.2
JUCM-2024-25	+0.04 +0.12	880	4,400	5.8
JUCM-2227-27	+0.04 +0.12	1,000	5,000	9.4
JUCM-2227-34	+0.04 +0.12	1,300	6,500	10.3
JUCM-2529-30	+0.04 +0.12	1,300	6,500	8.6
JUCM-3034-30	+0.04 +0.12	1,500	7,500	10.0

drylin® R solid plastic bearings | Product Range

Standard design – iglide® J

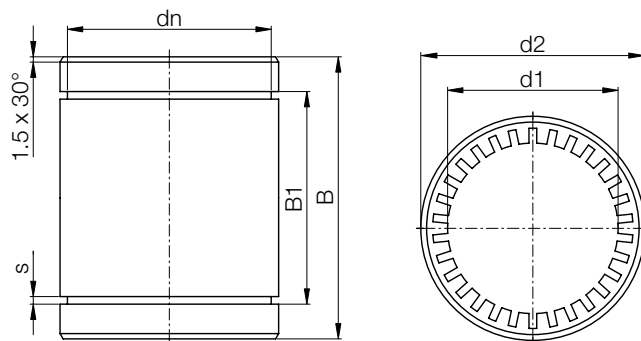

Order key

Type	Size
R J M - 01 - 12	
Closed	iglide® J
Metric	Standard
	Inner Ø d1

- Assembly by press-fitting using an arbor press
- Secured by snap ring



Min. -4°F (-20°C)
Max. +140°F (+60°C)



⁷⁸⁾ According to igus® testing method ▶ Page 1210

⁸²⁾ Design standards ▶ Page 1209

⁸³⁾ Applies by room temperature: press-fit decrease with time depending on the temperature

Please note: Installation instructions ▶ Page 1212

Dimensions [mm]

Part No.	d1	d2	B	B1	s	dn
RJM-01-08	8	16	25	16.2	1.10	15.2
RJM-01-10	10	19	29	21.6	1.30	17.5
RJM-01-12	12	22	32	22.6	1.30	20.5
RJM-01-16	16	26	36	24.6	1.30	24.2
RJM-01-20	20	32	45	31.2	1.60	29.6
RJM-01-25	25	40	58	43.7	1.85	36.5
RJM-01-30	30	47	68	51.7	1.85	43.5
RJM-01-40	40	62	80	60.3	2.15	57.8

Technical Data

Part No.	d1-Tolerance ⁸⁰⁾ after pressfit E9 [mm]	Fmax. dynamic ⁸²⁾ P = 2.5 MPa [N]	Fmax. static ⁸²⁾ P = 17.5 MPa [N]	Weight [g]	Pressfit force ⁸³⁾ [N]
	RJM-01-08	+0.025 +0.061	250	1,750	4
RJM-01-10	+0.032 +0.075	363	2,538	7	700
RJM-01-12	+0.032 +0.075	480	3,360	9	1,300
RJM-01-16	+0.032 +0.075	720	5,040	13	1,100
RJM-01-20	+0.040 +0.092	1,125	7,875	24	1,500
RJM-01-25	+0.040 +0.092	1,813	12,688	47	3,500
RJM-01-30	+0.040 +0.092	2,550	17,850	72	4,500
RJM-01-40	+0.050 +0.112	4,000	28,000	127	4,200

Can be combined with:



RQA-04



RTA-04



RGA-04



RGAS-04

drylin® R solid plastic bearings | Product Range

Standard design, low-clearance/precision – iglide® J

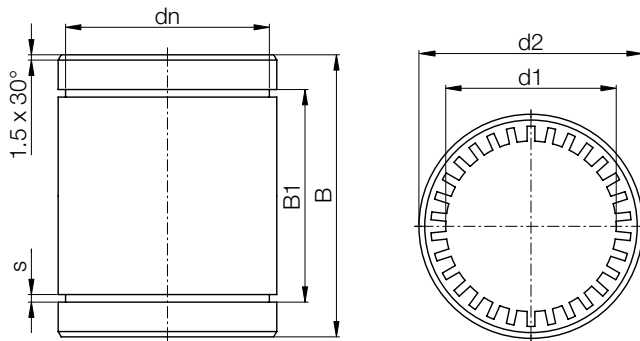

Type					Size
R	J	M	P	-01	-10
Closed	iglide® J	Metric	Low clearance	Standard	Inner Ø d1

- Easy assembly by light press-fit
- Reduced bearing clearance
- Secured by snap ring



Min. -4°F (-20°C)
Max. +140°F (+60°C)



⁷⁸⁾ According to igus® testing method ► Page 1210

⁸²⁾ Design standards ► Page 1209

⁸³⁾ Applies by room temperature: press-fit decrease with time depending on the temperature

Please note: Installation instructions ► Page 1212

Dimensions [mm]

Part No.	d1	d2	B	B1	s	dn
RJMP-01-06	6	12	19	13.5	1.10	11.5
RJMP-01-08	8	16	25	16.2	1.10	15.2
RJMP-01-10	10	19	29	21.6	1.30	17.5
RJMP-01-12	12	22	32	22.6	1.30	20.5
RJMP-01-16	16	26	36	24.6	1.30	24.2
RJMP-01-20	20	32	45	31.2	1.60	29.6
RJMP-01-25	25	40	58	43.7	1.85	36.5
RJMP-01-30	30	47	68	51.7	1.85	43.5

Technical Data

Part No.	d1-Tolerance ⁷⁸⁾	Fmax. dynamic ⁸²⁾	Fmax. static ⁸²⁾	Weight
	[mm]	P = 2.5 MPa [N]	P = 2.5 MPa [N]	
RJMP-01-06	+0.000 +0.030	200	1,400	2
RJMP-01-08	+0.000 +0.040	250	1,750	4
RJMP-01-10	+0.000 +0.040	363	2,538	7
RJMP-01-12	+0.000 +0.040	480	3,360	9
RJMP-01-16	+0.000 +0.040	720	5,040	13
RJMP-01-20	+0.000 +0.040	1,125	7,875	24
RJMP-01-25	+0.000 +0.050	1,813	12,688	47
RJMP-01-30	+0.000 +0.050	2,550	17,850	72

Can be combined with:



RQA-04



RTA-04



RGA-04



RGAS-04

drylin® R solid plastic bearings | Product Range

Linear plain bearings with Japanese dimensions - iglide® J4

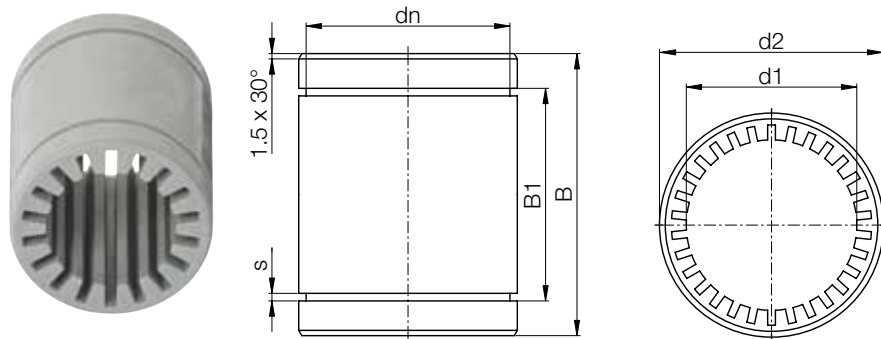

Order key

Type					Size
R J4 J P - 01 - 10					
Closed	iglide® J4	Japan standard	Precise	Standard	Inner Ø d1

- Alternative to ball bearings with Japanese dimension
- Quickly assembled
- Secured by snap ring

⁷⁸⁾ According to igus® testing method ► Page 1210⁸²⁾ Design standards ► Page 1209

Please note: Installation instructions ► Page 1212

Material properties J4 ► Page 1780



Min. -4°F (-20°C)

Max. +140°F (+60°C)

Dimensions [mm]

Part No.	d1	d2	B	B1	s	dn
RJ4JP-01-08	8	15	24	17.5	1.1	14.3
RJ4JP-01-10	10	19	29	22.0	1.3	18.0
RJ4JP-01-12	12	21	30	23.0	1.3	20.0
RJ4JP-01-16	16	28	37	26.5	1.6	26.6
RJ4JP-01-20	20	32	42	30.5	1.6	30.3
RJ4JP-01-25	25	40	59	41.1	1.85	37.5
RJ4JP-01-30	30	45	64	44.6	1.85	42.5

Technical data

Part No.	d1 tolerance ⁷⁸⁾	Fmax. dynamic ⁸²⁾	Fmax. static ⁸²⁾	Weight
	[mm]	p = 5MPa [N]	p = 35MPa [N]	
RJ4JP-01-08	+0.000 +0.040	200	800	2
RJ4JP-01-10	+0.000 +0.040	300	1,200	6
RJ4JP-01-12	+0.000 +0.040	400	1,600	8
RJ4JP-01-16	+0.000 +0.040	700	2,800	16
RJ4JP-01-20	+0.000 +0.040	1,000	4,000	23
RJ4JP-01-25	+0.000 +0.050	1,550	6,500	47
RJ4JP-01-30	+0.000 +0.050	2,200	8,500	72

drylin® R solid plastic bearings | Product Range

Low-cost linear plain bearings – iglide® J260

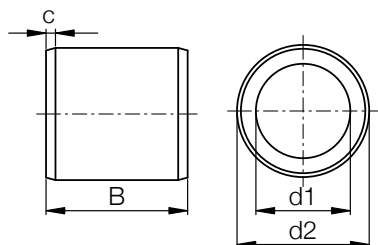
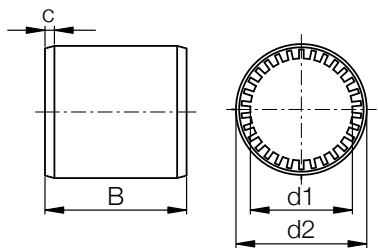

Order key

Type	Size
R J260 U M - 02 - 12	
Closed	iglide® J260
Grooved	Metric
Compact	Inner Ø d1

- 2 variations: RJ260M (with plain design) and RJ260UM (grooved inner diameter)



⁷⁸⁾ According to igus® testing method ▶ Page 1210

⁸²⁾ Design standards ▶ Page 1209

Please note: Installation instructions ▶ Page 1212



Min. -4°F (-20°C)

Max. +140°F (+60°C)

Dimensions [mm]

Part No.	d1	d2	B	C
RJ260UM-02-12	12	19	28	1.5x15°
RJ260UM-02-16	16	24	30	1.5x15°
RJ260UM-02-20	20	28	30	2.0x15°
RJ260UM-02-25	25	35	40	2.0x15°

Technical data

Part No.	d1 tolerance ⁷⁸⁾	Fmax. dynamic ⁸²⁾	Fmax. static ⁸²⁾	Weight
	[mm]	p = 2.5MPa [N]	p = 17.5MPa [N]	
RJ260UM-02-12	+0.035 +0.080	420	2,940	6.2
RJ260UM-02-16	+0.035 +0.080	600	4,200	9.7
RJ260UM-02-20	+0.040 +0.095	750	5,250	11.7
RJ260UM-02-25	+0.040 +0.095	1,250	8,750	22.8

drylin® R sliding discs | Product Range

Large force displacement on different surfaces – iglide® J

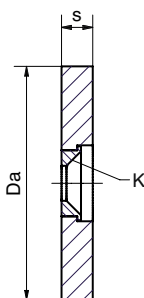
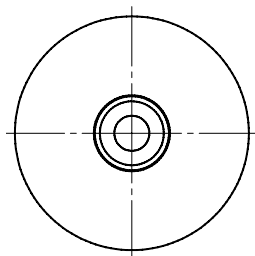

Order key

Type	Size
RSD J - 40 - 06	
Slide disc	iglide® J
Outer Ø	Inner Ø d1

- Made from the high-performance plastic iglide® J
- Low coefficient of friction
- Brass fitting for secure mounting



Min. -58°F (-50°C)
Max. +194°F (+90°C)

Dimensions [mm]

Part No.	Outer Ø Da	Wear limit	Width s	K For countersunk screw	Max. static load capacity [N]
RSDJ-40-06	40	1.5	6 ± 0.05	M6	28,500
RSDJ-60-08	60	2.5	8 ± 0.05	M8	66,000
RSDJ-80-08	80	2.5	8 ± 0.05	M8	120,000

drylin® R linear plain bearings | Product Range

Closed, anodized aluminum adapter - iglide® J liner

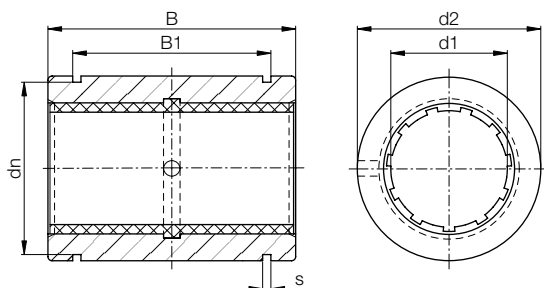

Order key

Type				Size	
R J U M - 01 - 10					
Closed	iglide® J	Liner	Metric	Standard	Inner Ø d1

- Dimensionally interchangeable with linear ball bearings
- Secured by snap ring
- Suitable shafting for iglide® J: drylin® AWM aluminum, case-hardened, 300 series stainless Best shafting for X: hard-chrome and hard-stainless steel

Dimensions [mm]

Part No.	d1	d1-Tolerance ⁷⁸⁾	d2	B	B1	s	dn	Housing Bore Recommendations	
								h7	h10
RJZM-01-05 ⁸¹⁾	5	+0.025 +0.060	12	22	14.2	1.10	11.5	12.000	12.018
RJZM-01-06 ⁸¹⁾	6	+0.025 +0.060	12	22	14.2	1.10	11.5	12.000	12.018
RJZM-01-08 ⁸¹⁾	8	+0.032 +0.070	16	25	16.2	1.10	15.2	16.000	16.018
RJUM-01-10	10	+0.030 +0.088	19	29	21.6	1.30	17.5	19.000	19.021
RJUM-01-12	12	+0.030 +0.088	22	32	22.6	1.30	20.5	22.000	22.021
RJUM-01-16	16	+0.030 +0.088	26	36	24.6	1.30	24.2	26.000	26.021
RJUM-01-20	20	+0.030 +0.091	32	45	31.2	1.60	29.6	32.000	32.025
RJUM-01-25	25	+0.030 +0.091	40	58	43.7	1.85	36.5	40.000	40.025
RJUM-01-30	30	+0.040 +0.110	47	68	51.7	1.85	43.5	47.000	47.025
RJUM-01-40	40	+0.040 +0.115	62	80	60.3	2.15	57.8	62.000	62.030
RJUM-01-50	50	+0.050 +0.150	75	100	77.3	2.65	70.5	75.000	75.030
RJUM-01-60	60	+0.050 +0.150	90	125	101.7	3.15	86.5	90.000	90.040

Technical Data

Part No.	F max, dynamic ⁸²⁾	F max, static ⁸²⁾
	$\rho = 5 \text{ MPa [N]}$	$\rho = 35 \text{ MPa [N]}$
RJZM-01-05 ⁸¹⁾	525	3,675
RJZM-01-06 ⁸¹⁾	525	3,675
RJZM-01-08 ⁸¹⁾	960	6,720
RJUM-01-10	725	5,075
RJUM-01-12	960	6,720
RJUM-01-16	1,440	10,080
RJUM-01-20	2,250	15,750
RJUM-01-25	3,625	25,375
RJUM-01-30	5,100	35,700
RJUM-01-40	8,000	56,000
RJUM-01-50	9,000	87,500
RJUM-01-60	12,000	120,000



⁷⁸⁾ According to igus® testing method ► Page 1210

⁸¹⁾ Ø < 10mm use press-fitted sleeve plain bearings

⁸²⁾ Design standards ► Page 1209

Please note: Installation instructions ► Page 1212

J200 - for Aluminum shafting

A180 - FDA compliant

X - High temperature and chemical resistance

E7 - for steel and stainless steel shafting

Can be combined with:



RQA-01



RTA-01



RGA-01



RGAS-01



E7



X

Available with drylin® liners

- X liner optional for chemicals/high temps up to +482°F (+250°C) for steel housing, up to +356°F (+180°C) for aluminum

Optional



J200



A180

drylin® R linear plain bearings | Product Range

Closed, anodized aluminum adapter, Low clearance - iglide® J liner

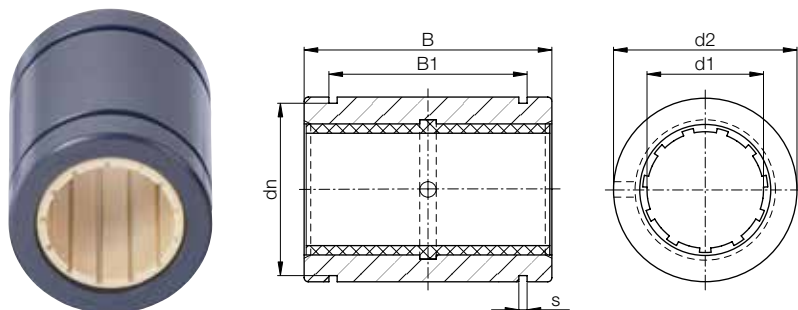

- Dimensionally interchangeable with linear ball bearings
- Secured by snap ring
- Suitable shafting for iglide® J: drylin® AWM aluminum, case-hardened, 300 series stainless Best shafting for X: hard-chrome and hard-stainless steel

Dimensions [mm]

Part No.	d1	d1-Tolerance ⁷⁸⁾	d2		B		s	dn
			h7	h10	H10	H10		
RJUM-11-10	10	+0.000 +0.058	19	29	21.6	1.30	17.5	
RJUM-11-12	12	+0.000 +0.058	22	32	22.6	1.30	20.5	
RJUM-11-16	16	+0.000 +0.058	26	36	24.6	1.30	24.2	
RJUM-11-20	20	+0.000 +0.061	32	45	31.2	1.60	29.6	
RJUM-11-25	25	+0.000 +0.061	40	58	43.7	1.85	36.5	
RJUM-11-30	30	+0.000 +0.075	47	68	51.7	1.85	43.5	
RJUM-11-40	40	+0.000 +0.080	62	80	60.3	2.15	57.8	
RJUM-11-50	50	+0.000 +0.090	75	100	77.3	2.65	70.5	



Order key

Type	Size
R J U M - 11 - 10	
Closed	Inner Ø d1
iglide® J	
Liner	
Metric	
Low-clearance	

Part formerly known as RJUM-21-XX

Housing Bore Recommendations	
Min.	Max.
19.000	19.021
22.000	22.021
26.000	26.021
32.000	32.025
40.000	40.025
47.000	47.025
62.000	62.030
75.000	75.030

Technical Data

Part No.	F max, dynamic ⁸²⁾	F max, static ⁸²⁾
	p = 5 MPa [N]	p = 35 MPa [N]
RJUM-11-10	725	5,075
RJUM-11-12	960	6,720
RJUM-11-16	1,440	10,080
RJUM-11-20	2,250	15,750
RJUM-11-25	3,625	25,375
RJUM-11-30	5,100	35,700
RJUM-11-40	8,000	56,000
RJUM-11-50	12,500	87,500

⁷⁸⁾ According to igus® testing method ► Page 1210⁸²⁾ Design standards ► Page 1209

Please note: Installation instructions ► Page 1212

J200 - for Aluminum shafting

A180 - FDA compliant

X - High temperature and chemical resistance

E7 - for steel and stainless steel shafting

Can be combined with:



RQA-01



RTA-01



RGA-01



RGAS-01

Available with drylin® liners



E7



X

- X liner optional for chemicals/high temps up to +482°F (+250°C) for steel housing, up to +356°F (+180°C) for aluminum

Optional



J200



A180

drylin® R linear plain bearings | Product Range

Closed, aluminum adapter (floating bearing) - iglide® J liner

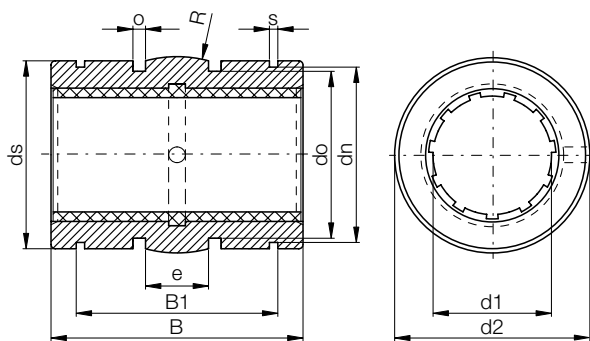

Type	Size
R J U M-03-10	
Closed	
iglide® J	
Liner	
Metric	
Self-aligning	
Inner Ø d1	

- With reduced outer diameter, spherical area on the outer diameter for automatic alignment compensation, O-rings for elastic seating, hard-anodized surface
- Dimensionally interchangeable with linear ball bearings



⁷⁸⁾ According to igus® testing method ► Page 1210
⁸¹⁾ Ø < 10 mm use iglide® JSM sleeve bearings
⁸²⁾ Design standards ► Page 1209
 Please note: Installation instructions ► Page 1212
 Floating bearing ► Page 1209

Dimensions [mm]

Part No.	Housing bore Ø H7 [mm]	d1 Tolerance ⁷⁸⁾	d2 h8	B h10	B1 H10	s H10	dn h10	ds h10	do	o +0.1	e	R
RJZM-03-08 ⁸¹⁾	16	+0.032 +0.070	15.8	24.9	16.4	1.10	15.0	15.5	13.2	1.86	5.0	20.0
RJUM-03-10	19	+0.030 +0.088	18.8	28.9	21.8	1.30	17.5	18.5	15.4	1.86	5.0	13.0
RJUM-03-12	22	+0.030 +0.088	21.8	31.9	22.8	1.30	20.5	21.5	18.4	1.86	6.0	18.0
RJUM-03-16	26	+0.030 +0.088	25.8	35.9	24.9	1.30	24.2	25.5	20.4	2.86	8.0	32.0
RJUM-03-20	32	+0.030 +0.091	31.8	44.8	31.5	1.60	29.6	31.5	26.4	2.86	10.0	50.0
RJUM-03-25	40	+0.030 +0.091	39.8	57.8	44.1	1.85	36.5	39.0	34.4	2.86	12.5	39.0
RJUM-03-30	47	+0.040 +0.110	46.7	67.8	52.1	1.85	43.5	46.0	41.4	2.86	15.0	57.0
RJUM-03-40	62	+0.040 +0.115	61.7	79.8	60.9	2.15	57.8	61.0	56.4	2.86	20.0	100.0
RJUM-03-50	75	+0.050 +0.150	74.7	99.8	78.0	2.65	70.5	74.0	69.4	2.86	25.0	157.0

Technical Data

Part No.	F max, dynamic ⁸²⁾ p = 5 MPa [N]	F max, static ⁸²⁾ p = 35 MPa [N]
RJZM-03-08 ⁸¹⁾	960	6,720
RJUM-03-10	725	5,075
RJUM-03-12	960	6,720
RJUM-03-16	1,440	10,080
RJUM-03-20	2,250	15,750
RJUM-03-25	3,625	25,375
RJUM-03-30	5,100	35,700
RJUM-03-40	8,000	56,000
RJUM-03-50	12,500	87,500

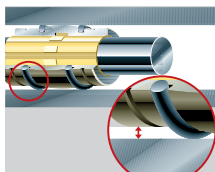

J200 - for Aluminum shafting
A180 - FDA compliant
X - High temperature and chemical resistance
E7 - for steel and stainless steel shafting

Can be combined with:



RQA-03



RTA-03



RGA-03



RGAS-03



E7



X

Available with drylin® liners

- X liner optional for chemicals/high temps up to +482°F (+250°C) for steel housing, up to +356°F (+180°C) for aluminum

Optional



J200



A180

drylin® R linear plain bearings | Product Range

Closed, anodized aluminum adapter, short design - iglide® J liner

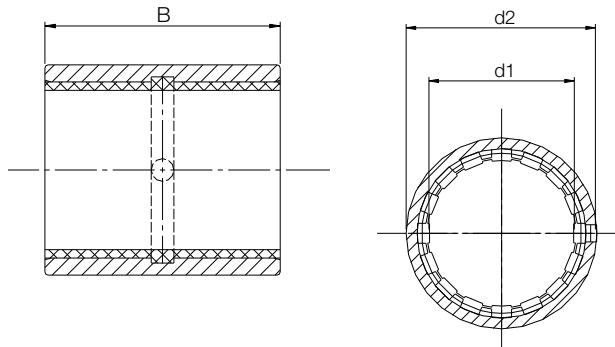

Type					Size
R	J	U	M	-02	-10
Closed	iglide® J	Liner	Metric	-02 = Standard -12 = Low-clearance	Inner Ø d1

- Dimensionally interchangeable with linear ball bearings
- Secured by pressfit in a recommended housing bore
- Recommended housing bore H7 for steel housings or K7 for aluminum



⁷⁸⁾ According to igus® testing method ► Page 1210

⁸¹⁾ Ø < 10mm use press-fitted sleeve bearings

⁸²⁾ Design standards ► Page 1209

Please note: Installation instructions ► Page 1212

RJUM-02, Standard Clearance

Dimensions [mm]

Part No.	Housing bore Ø H7/K7 [mm]	d1 Tolerance ⁷⁸⁾	F max.	F max.	Weight (g)	d1	d2 k7	B h10
			Dynamic Load [N]	Static Load [N]				
			P = 5 MPa	P = 35 MPa				
RJZM-02-06 ⁸¹⁾	12	+0.025 - +0.060	600	4200	4	6	12	22
RJZM-02-08 ⁸¹⁾	15	+0.032 - +0.070	650	4550	6	8	15	24
RJUM-02-10	17	+0.030 - +0.088	650	4550	8	10	17	26
RJUM-02-12	19	+0.030 - +0.088	840	5880	10	12	19	28
RJUM-02-16	24	+0.030 - +0.088	1200	8400	17	16	24	30
RJUM-02-20	28	+0.030 - +0.091	1500	10500	18	20	28	30
RJUM-02-25	35	+0.030 - +0.091	2500	17500	42	25	35	40
RJUM-02-30	40	+0.040 - +0.110	3750	26250	56	30	40	50
RJUM-02-40	52	+0.040 - +0.115	6000	42000	113	40	52	60
RJUM-02-50	60	+0.050 - +0.150	8750	61250	147	50	60	70

RJUM-12, Low Clearance

Dimensions [mm]

Part No.	Housing bore Ø H7/K7 [mm]	d1 Tolerance ⁷⁸⁾	F max.	F max.	Weight (g)	d1	d2 k7	B h10
			Dynamic ⁸²⁾ Load [N]	Static ⁸²⁾ Load [N]				
			P = 5 MPa	P = 35 MPa				
RJUM-12-10	17	.015 - .044	650	4550	8	10	17	26
RJUM-12-12	19	.015 - .044	840	5880	10	12	19	28
RJUM-12-16	24	.015 - .044	1200	8400	17	16	24	30
RJUM-12-20	28	.015 - .045	1500	10500	18	20	28	30
RJUM-12-25	35	.015 - .045	2500	17500	42	25	35	40
RJUM-12-30	40	.020 - .055	3750	26250	56	30	40	50
RJUM-12-40	52	.020 - .057	6000	42000	113	40	52	60
RJUM-12-50	60	.025 - .065	8750	61250	147	50	60	70

drylin® R linear plain bearings | Product Range

Closed, anodized aluminum adapter - iglide® J200 liner

For aluminum shafting

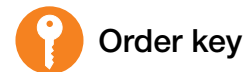
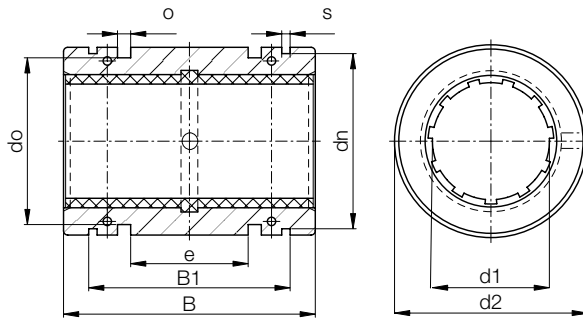

Type					Size
R J200 U M-01-10					
Closed	iglide® J200	Liner	Metric	Standard	Inner Ø d1

- Suitable shafting for iglide® J200: Hard anodized aluminum
- Secured by snap ring
- Dimensionally interchangeable with linear ball bearings



⁷⁸⁾ According to igus® testing method ▶ Page 1210

⁸²⁾ Design standards ▶ Page 1209

Please note: Installation instructions ▶ Page 1212

Dimensions [mm]

Part No.	d1	d1-Tolerance ⁷⁸⁾	d2		B		s		dn	
			h7	h10	H10	H10	H10	H10	h10	h10
RJ200UM-01-10	10	+0.030 +0.088	19	29	21.6	1.30	17.5			
RJ200UM-01-12	12	+0.030 +0.088	22	32	22.6	1.30	20.5			
RJ200UM-01-16	16	+0.030 +0.088	26	36	24.6	1.30	24.2			
RJ200UM-01-20	20	+0.030 +0.091	32	45	31.2	1.60	29.6			
RJ200UM-01-25	25	+0.030 +0.091	40	58	43.7	1.85	36.5			
RJ200UM-01-30	30	+0.040 +0.110	47	68	51.7	1.85	43.5			
RJ200UM-01-40	40	+0.040 +0.115	62	80	60.3	2.15	57.8			
RJ200UM-01-50	50	+0.050 +0.150	75	100	77.3	2.65	70.5			

Technical Data

Part No.	F max, dynamic ⁸²⁾	F max, static ⁸²⁾
	p = 5 MPa [N]	p = 35 MPa [N]
RJ200UM-01-10	725	5,075
RJ200UM-01-12	960	6,720
RJ200UM-01-16	1,440	10,080
RJ200UM-01-20	2,250	15,750
RJ200UM-01-25	3,625	25,375
RJ200UM-01-30	5,100	35,700
RJ200UM-01-40	8,000	56,000
RJ200UM-01-50	9,000	87,500

J200 - for Aluminum shafting

A180 - FDA compliant

X - High temperature and chemical resistance

E7 - for steel and stainless steel shafting

Can be combined with:



RQA-01



RTA-01



RGA-01



RGAS-01

Available with drylin® liners



J



E7



X

- X liner optional for chemicals/high temps up to +482°F (+250°C) for steel housing, up to +356°F (+180°C) for aluminum

drylin® R linear plain bearings | Product Range

Closed, anodized aluminum adapter, self-aligning - iglide® J200 liner

For aluminum shafting

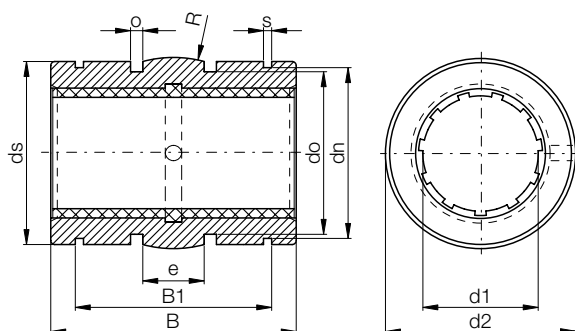

Order key

Type				Size	
R J200 U M-03-10					
Closed	iglide® J200	Liner	Metric	Self-aligning	Inner Ø d1

- Suitable shafting for iglide® J200: Hard anodized aluminum
- Secured by snap ring
- Dimensionally interchangeable with linear ball bearings

⁷⁸⁾ According to igus® testing method ► Page 1210⁸²⁾ Design standards ► Page 1209

Please note: Installation instructions ► Page 1212

Dimensions [mm]

Part No.	Housing bore Ø H7 [mm]	d1 Tolerance ⁷⁸⁾	d2	B	B1	s	dn	ds	do	o	e	R
			h8	h10	H10	H10	h10	h10		+0.1		
RJ200UM-03-10	19	+0.030 +0.088	18.8	28.9	21.8	1.30	17.5	18.5	15.4	1.86	5.0	13.0
RJ200UM-03-12	22	+0.030 +0.088	21.8	31.9	22.8	1.30	20.5	21.5	18.4	1.86	6.0	18.0
RJ200UM-03-16	26	+0.030 +0.088	25.8	35.9	24.9	1.30	24.2	25.5	20.4	2.86	8.0	32.0
RJ200UM-03-20	32	+0.030 +0.091	31.8	44.8	31.5	1.60	29.6	31.5	26.4	2.86	10.0	50.0
RJ200UM-03-25	40	+0.030 +0.091	39.8	57.8	44.1	1.85	36.5	39.0	34.4	2.86	12.5	39.0
RJ200UM-03-30	47	+0.040 +0.110	46.7	67.8	52.1	1.85	43.5	46.0	41.4	2.86	15.0	57.0
RJ200UM-03-40	62	+0.040 +0.115	61.7	79.8	60.9	2.15	57.8	61.0	56.4	2.86	20.0	100.0
RJ200UM-03-50	75	+0.050 +0.150	74.7	99.8	78.0	2.65	70.5	74.0	69.4	2.86	25.0	157.0

Technical Data

Part No.	F max, dynamic ⁸²⁾ p = 5 MPa [N]	F max, static ⁸²⁾ p = 35 MPa [N]
RJ200UM-03-10	725	5,075
RJ200UM-03-12	960	6,720
RJ200UM-03-16	1,440	10,080
RJ200UM-03-20	2,250	15,750
RJ200UM-03-25	3,625	25,375
RJ200UM-03-30	5,100	35,700
RJ200UM-03-40	8,000	56,000
RJ200UM-03-50	9,000	87,500

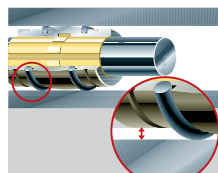

J200 - for Aluminum shafting

A180 - FDA compliant

X - High temperature and chemical resistance

E7 - for steel and stainless steel shafting

Can be combined with:



RQA-03



RTA-03



RGA-03



RGAS-03

Available with drylin® liners



J



E7



X

- X liner optional for chemicals/high temps up to +482°F (+250°C) for steel housing, up to +356°F (+180°C) for aluminum

drylin® R linear plain bearings | Product Range

Closed, anodized aluminum adapter - iglide® E7 liner
For steel, hard chrome steel, and stainless steel

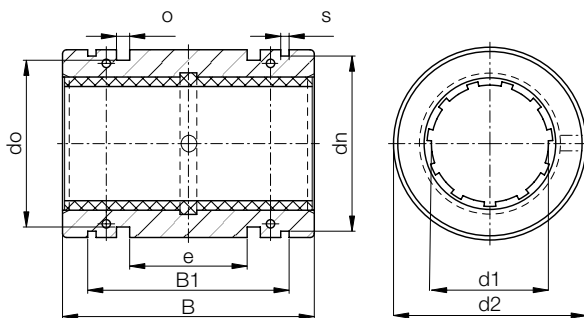

Order key

Type	Size
R E7 U M -01 -10	
Closed	iglide® E7
Liner	Metric
Standard	Diameter

- Suitable shafting for iglide® E7: Steel/stainless steel
- Secured by snap ring
- Dimensionally interchangeable with linear ball bearings

Dimensions [mm]

Part No.	d1	d1-Tolerance ⁷⁸⁾	d2	B	B1	s	dn
			h7	h10	H10	H10	h10
RE7UM-01-10	10	+0.030 +0.088	19	29	21.6	1.30	17.5
RE7UM-01-12	12	+0.030 +0.088	22	32	22.6	1.30	20.5
RE7UM-01-16	16	+0.030 +0.088	26	36	24.6	1.30	24.2
RE7UM-01-20	20	+0.030 +0.091	32	45	31.2	1.60	29.6
RE7UM-01-25	25	+0.030 +0.091	40	58	43.7	1.85	36.5
RE7UM-01-30	30	+0.040 +0.110	47	68	51.7	1.85	43.5
RE7UM-01-40	40	+0.040 +0.115	62	80	60.3	2.15	57.8
RE7UM-01-50	50	+0.050 +0.180	75	100	77.3	2.65	70.5
RE7UM-01-60	60	+0.050 +0.190	90	125	101.7	3.15	86.5

Technical Data

Part No.	F max, dynamic ⁷⁸⁾ p = 2.5 MPa [N]	F max, static ⁸²⁾ p = 18 MPa [N]
RE7UM-01-10	360	2,610
RE7UM-01-12	480	3,450
RE7UM-01-16	720	5,180
RE7UM-01-20	1,120	8,100
RE7UM-01-25	1,810	13,050
RE7UM-01-30	2,550	18,360
RE7UM-01-40	4,000	28,800
RE7UM-01-50	4,500	45,000
RE7UM-01-60	6,000	61,700



⁷⁸⁾ According to igus® testing method ▶ Page 1210

⁸²⁾ Design standards ▶ Page 1209

Please note: Installation instructions ▶ Page 1212

J200 - for Aluminum shafting

A180 - FDA compliant

X - High temperature and chemical resistance

E7 - for steel and stainless steel shafting

Can be combined with:



RQA-01



RTA-01



RGA-01



RGAS-01

Available with drylin® liners



J



X

- X liner optional for chemicals/high temps up to +482°F (+250°C) for steel housing, up to +356°F (+180°C) for aluminum

Optional



J200



A180

drylin® R linear plain bearings | Product Range

Closed, anodized aluminum adapter, self-aligning - iglide® E7 liner
For steel, hard chrome steel, and stainless steel

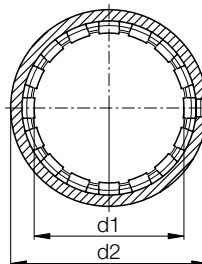
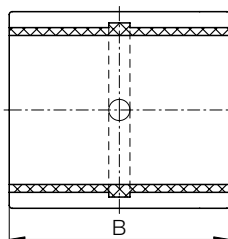

Order key

Type				Size	
R E7 U M -02 -10					
Closed	iglide® E7	Liner	Metric	Self-aligning	Diameter



⁷⁸⁾ According to igus® testing method ► Page 1210

⁸²⁾ Design standards ► Page 1209

Please note: Installation instructions ► Page 1212

Dimensions [mm]

Part No.	d1	d2	B
		k7	h10
RE7UM-02-10	10	17	26
RE7UM-02-12	12	19	28
RE7UM-02-16	16	24	30
RE7UM-02-20	20	28	30
RE7UM-02-25	25	35	40
RE7UM-02-30	30	40	50
RE7UM-02-40	40	52	60
RE7UM-02-50	50	62	70

Technical Data

Part No.	Housing hole	d1 tolerance ⁷⁸⁾	F max. dynamic ⁸²⁾	F max. static ⁸²⁾	Weight
	Ø H7 [mm]	[mm]	p = 2.5 MPa [N]	p = 18 MPa [N]	
RE7UM-02-10	17	+0.030 +0.088	325	2,340	8
RE7UM-02-12	19	+0.030 +0.088	420	3,020	10
RE7UM-02-16	24	+0.030 +0.088	600	4,320	17
RE7UM-02-20	28	+0.030 +0.091	750	5,400	18
RE7UM-02-25	35	+0.030 +0.091	1,250	9,000	42
RE7UM-02-30	40	+0.040 +0.110	1,875	13,500	56
RE7UM-02-40	52	+0.040 +0.115	3,000	21,600	113
RE7UM-02-50	62	+0.050 +0.180	4,375	31,500	147

drylin® R linear plain bearings | Product Range

Closed, anodized aluminum adapter, self-aligning - iglide® E7 liner
For steel, hard chrome steel, and stainless steel

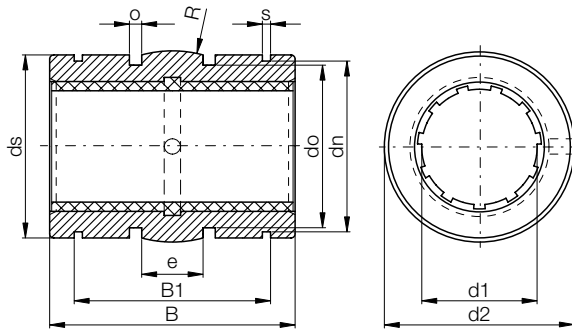

Order key

Type	Size
R E7 U M -03 -10	
Closed	iglide® E7
Liner	Metric
Self-aligning	Diameter

- Suitable shafting for iglide® E7: Steel/stainless steel
- Secured by snap ring
- Dimensionally interchangeable with linear ball bearings



⁷⁸⁾ According to igus® testing method ► Page 1210
⁸²⁾ Design standards ► Page 1209

Please note: Installation instructions ► Page 1212

Dimensions [mm]

Part No.	Housing bore Ø H7 [mm]	d1 Tolerance ⁷⁸⁾	d2	B	B1	s	dn	ds	do	o	e	R
			h8	h10	H10	H10	h10	h10	h10	+0.1		
RE7UM-03-10	19	+0.030 +0.088	18.8	28.9	21.8	1.30	17.5	18.5	15.4	1.86	5.0	13.0
RE7UM-03-12	22	+0.030 +0.088	21.8	31.9	22.8	1.30	20.5	21.5	18.4	1.86	6.0	18.0
RE7UM-03-16	26	+0.030 +0.088	25.8	35.9	24.9	1.30	24.2	25.5	20.4	2.86	8.0	32.0
RE7UM-03-20	32	+0.030 +0.091	31.8	44.8	31.5	1.60	29.6	31.5	26.4	2.86	10.0	50.0
RE7UM-03-25	40	+0.030 +0.091	39.8	57.8	44.1	1.85	36.5	39.0	34.4	2.86	12.5	39.0
RE7UM-03-30	47	+0.040 +0.110	46.7	67.8	52.1	1.85	43.5	46.0	41.4	2.86	15.0	57.0
RE7UM-03-40	62	+0.040 +0.115	61.7	79.8	60.9	2.15	57.8	61.0	56.4	2.86	20.0	100.0
RE7UM-03-50	75	+0.050 +0.180	74.7	99.8	78.0	2.65	70.5	74.0	69.4	2.86	25.0	157.0

Technical Data

Part No.	F max, dynamic ⁸²⁾ p = 2.5 MPa [N]	F max, static ⁸²⁾ p = 18 MPa [N]
RE7UM-03-10	360	2,610
RE7UM-03-12	480	3,450
RE7UM-03-16	720	5,180
RE7UM-03-20	1,120	8,100
RE7UM-03-25	1,810	13,050
RE7UM-03-30	2,550	18,360
RE7UM-03-40	4,000	28,800
RE7UM-03-50	4,500	45,000

J200 - for Aluminum shafting

A180 - FDA compliant

X - High temperature and chemical resistance

E7 - for steel and stainless steel shafting

Can be combined with:



RQA-03



RTA-03



RGA-03



RGAS-03



J



X

Available with drylin® liners

- X liner optional for chemicals/high temps up to +482°F (+250°C) for steel housing, up to +356°F (+180°C) for aluminum

Optional



J200



A180

drylin® R linear plain bearings | Product Range

Closed, 303 stainless steel adapter (1.4305) - iglide® J liner

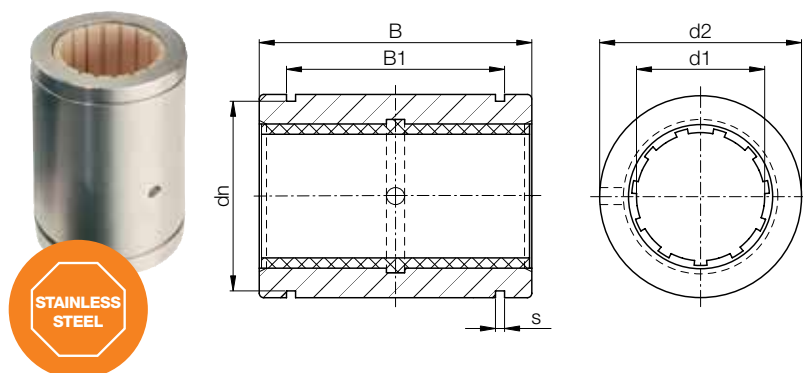
 Order key

Type	Size	Option
R J U M - 01 - 12 - ES		
Closed	iglide® J	Liner
		Metric
		Standard
	Diameter	
		Stainless steel

- Dimensionally interchangeable with linear ball bearings
- Secured by snap ring

⁷⁸⁾ According to igus® testing method ► Page 1210

⁸¹⁾ Ø < 10 mm use iglide® JSM sleeve bearings

⁸²⁾ Design standards ► Page 1209

Please note: Installation instructions ► Page 1212

Dimensions [mm]

Part No.	d1	d1-Tolerance ⁷⁸⁾	d2	B	B1	s	dn
			h7	h10	H10	H10	h10
RJUM-01-12ES	12	+0.030 +0.088	22	32	22.6	1.30	20.5
RJUM-01-16ES	16	+0.030 +0.088	26	36	24.6	1.30	24.2
RJUM-01-20ES	20	+0.030 +0.091	32	45	31.2	1.60	29.6
RJUM-01-25ES	25	+0.030 +0.091	40	58	43.7	1.85	36.5
RJUM-01-30ES	30	+0.040 +0.110	47	68	51.7	1.85	43.5

Technical Data

Part No.	F max, dynamic ⁸²⁾ p = 5 MPa [N]	F max, static ⁸²⁾ p = 35 MPa [N]	Weight [g]
RJUM-01-12-ES	960	6,720	60
RJUM-01-16-ES	1,440	10,080	84
RJUM-01-20-ES	2,250	15,750	147
RJUM-01-25-ES	3,625	25,375	324
RJUM-01-30-ES	5,100	35,700	486

J200 - for Aluminum shafting

A180 - FDA compliant

X - High temperature and chemical resistance

E7 - for steel and stainless steel shafting

Available with drylin® liners



J200



E7



X

- X liner optional for chemicals/high temps
up to +482°F (+250°C) for steel housing,
up to +356°F (+180°C) for aluminum

drylin® R linear plain bearings | Product Range

Split, anodized aluminum adapter - iglide® J liner

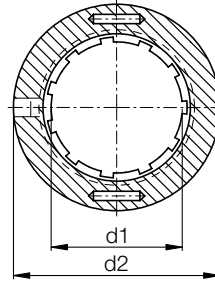
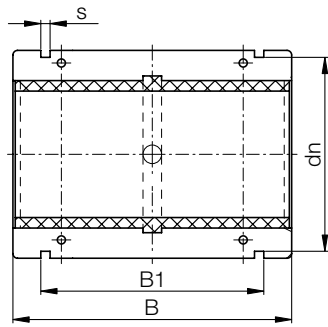
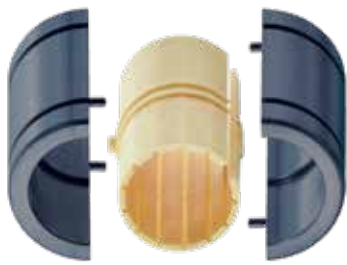

Size					Size
T	J	U	M	-01	-10
Split	iglide® J	Liner	Metric	Standard	Inner Ø d1

- Dimensionally interchangeable with linear ball bearings
- Quick replacement of bearing lining without dismantling the shaft

Dimensions [mm]

Part No.	d1	d2	B		s	dn
			h10	H10		
TJUM-01-10	10	19	-0.020	-0.040	1.30	17.5
TJUM-01-12	12	22	-0.020	-0.040	1.30	20.5
TJUM-01-16	16	26	-0.020	-0.040	1.30	24.2
TJUM-01-20	20	32	-0.020	-0.045	1.60	29.6
TJUM-01-25	25	40	-0.030	-0.055	1.85	36.5
TJUM-01-30	30	47	-0.030	-0.055	1.85	43.5
TJUM-01-40	40	62	-0.030	-0.060	2.15	57.8
TJUM-01-50	50	75	-0.030	-0.160	2.65	70.5

Housing Bore Recommendations	
Min.	Max.
19.000	19.021
22.000	22.021
26.000	26.021
32.000	32.025
40.000	40.025
47.000	47.025
62.000	62.030
75.000	75.030

Technical Data

Part No.	d1-Tolerance ⁷⁸⁾ [mm]	F max. dynamic ⁸²⁾		Weight [g]
		P = 5 MPa		
		[N]		
TJUM-01-10	+0.030 +0.092	725	5,075	14
TJUM-01-12	+0.030 +0.097	960	6,720	19
TJUM-01-16	+0.030 +0.097	1,440	10,080	27
TJUM-01-20	+0.030 +0.103	2,250	15,750	49
TJUM-01-25	+0.030 +0.103	3,625	25,375	106
TJUM-01-30	+0.040 +0.124	5,100	35,700	166
TJUM-01-40	+0.040 +0.124	8,000	56,000	347
TJUM-01-50	+0.050 +0.196	12,500	87,500	577



⁷⁸⁾ According to igus® testing method ▶ Page 1210

⁸²⁾ Design standards ▶ Page 1209

Please note: Installation instructions ▶ Page 1212

J200 - for Aluminum shafting

A180 - FDA compliant

X - High temperature and chemical resistance

E7 - for steel and stainless steel shafting

Can be combined with:



RQA-01



RTA-01



RGA-01



RGAS-01



E7



X

Available with drylin® liners

- X liner optional for chemicals/high temps up to +482°F (+250°C) for steel housing, up to +356°F (+180°C) for aluminum

drylin® R linear plain bearings | Product Range

Split, anodized aluminum adapter , self-aligning - iglide® J liner

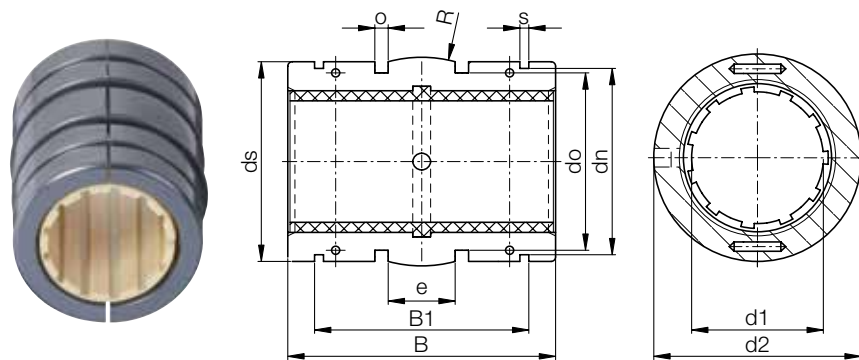

Order key

Size	Size
T J U M-03-10	
Split	iglide® J
Liner	Metric
Self-aligning	Inner Ø d1

- With spherical area on the outer diameter for self-aligning purposes and O-rings for elastic seating
- Dimensionally interchangeable with linear ball bearings

Dimensions [mm]

Part No.	d1	d2	B	B1	s	dn	ds	do	o	e	R
			h10	H10	H10	h10	h10		+0.1		
TJUM-03-10	10	19 -0.020 -0.040	28.9	21.8	1.30	17.5	18.5	15.4	1.86	5.0	13.0
TJUM-03-12	12	22 -0.020 -0.040	31.9	22.8	1.30	20.5	21.5	18.4	1.86	6.0	18.0
TJUM-03-16	16	26 -0.020 -0.040	35.9	24.9	1.30	24.2	25.5	20.4	2.86	8.0	32.0
TJUM-03-20	20	32 -0.020 -0.045	44.8	31.5	1.60	29.6	31.5	26.4	2.86	10.0	50.0
TJUM-03-25	25	40 -0.030 -0.055	57.8	44.1	1.85	36.5	39.0	34.4	2.86	12.5	39.0
TJUM-03-30	30	47 -0.030 -0.055	67.8	52.1	1.85	43.5	46.0	41.4	2.86	15.0	57.0
TJUM-03-40	40	62 -0.030 -0.060	79.8	60.9	2.15	57.8	61.0	56.4	2.86	20.0	100.0
TJUM-03-50	50	75 -0.030 -0.060	99.8	78.0	2.65	70.5	74.0	69.4	2.86	25.0	157.0

Technical Data

Part No.	d1-Tolerance ⁷⁸⁾ [mm]	F max. dynamic ⁸²⁾ P = 5 MPa [N]	F max. static ⁸²⁾ P = 35 MPa [N]	Weight [g]
TJUM-03-10	+0.030 +0.092	725	5,075	11
TJUM-03-12	+0.030 +0.097	960	6,720	17
TJUM-03-16	+0.030 +0.097	1,440	10,080	23
TJUM-03-20	+0.030 +0.103	2,250	15,750	44
TJUM-03-25	+0.030 +0.103	3,625	25,375	92
TJUM-03-30	+0.040 +0.124	5,100	35,700	145
TJUM-03-40	+0.040 +0.124	8,000	56,000	311
TJUM-03-50	+0.050 +0.196	12,500	87,500	542

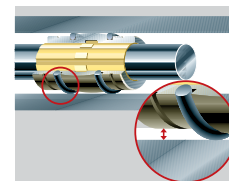

i ⁷⁸⁾ According to igus® testing method ▶ Page 1210
⁸²⁾ Design standards ▶ Page 1209
 Please note: Installation instructions ▶ Page 1212
 Floating bearing ▶ Page 1209

J200 - for Aluminum shafting
A180 - FDA compliant
X - High temperature and chemical resistance
E7 - for steel and stainless steel shafting

Can be combined with:



Available with drylin® liners



- X liner optional for chemicals/high temps up to +482°F (+250°C) for steel housing, up to +356°F (+180°C) for aluminum

Optional



drylin® R linear plain bearings | Product Range

Open, anodized aluminum adapter - iglide® J liner

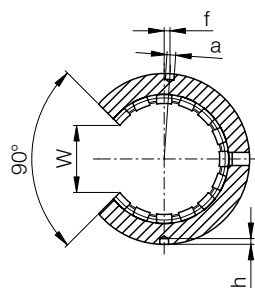
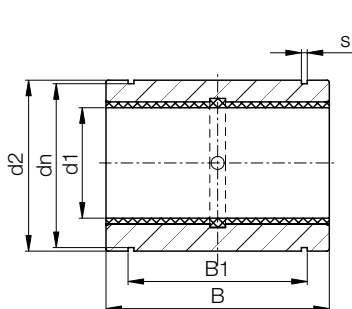

Order key

Size Size

O J U M-01-10

Open	iglide® J	Liner	Metric	Standard	Inner Ø d1
------	-----------	-------	--------	----------	------------

- For supported shafts
- Dimensionally interchangeable with linear ball bearings

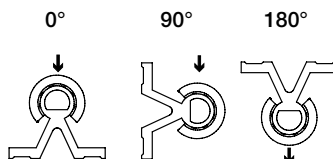

Dimensions [mm]

Part No.	d1	d2	B	W	a	dn	B1	s	f	h
		h7	h10	-1	+0.1	h10	H10	H10	±0.2	-0.5
OJUM-01-10	10	19	29	7.3	0.0	17.5	21.6	1.30	0	1.2
OJUM-01-12	12	22	32	9.0	3.0	20.5	22.6	1.30	1.33 (7°)	1.2
OJUM-01-16	16	26	36	11.6	2.2	24.2	24.6	1.30	0	1.2
OJUM-01-20	20	32	45	12.0	2.2	29.6	31.2	1.60	0	1.2
OJUM-01-25	25	40	58	14.5	3.0	36.5	43.7	1.85	-1.5 (-4.3°)	1.5
OJUM-01-30	30	47	68	16.6	3.0	43.5	51.7	1.85	2 (4.9°)	2.0
OJUM-01-40	40	62	80	21.0	3.0	57.8	60.3	2.15	1.5 (2.8°)	2.0
OJUM-01-50	50	75	100	25.5	5.0	70.5	77.3	2.65	2.5 (3.8°)	2.0

Technical Data

Part No.	d1-Tolerance ⁷⁸⁾	F max. [N] dynamic ⁸²⁾			F max. [N] static ⁸²⁾			Weight [g]
		P = 5 MPa			P = 35 MPa			
		0°	90°	180°	0°	90°	180°	
OJUM-01-10	+0.030 +0.088	725	500	196	5,075	3,500	1,370	11
OJUM-01-12	+0.030 +0.088	960	635	240	6,720	4,445	1,680	15
OJUM-01-16	+0.030 +0.088	1,440	990	396	10,080	6,943	2,772	21
OJUM-01-20	+0.030 +0.091	2,250	1,800	900	15,750	12,600	6,300	42
OJUM-01-25	+0.030 +0.091	3,625	2,953	1,523	25,375	20,670	10,658	70
OJUM-01-30	+0.040 +0.110	5,100	4,250	2,278	35,700	29,735	15,946	132
OJUM-01-40	+0.040 +0.115	8,000	6,810	3,800	56,000	47,660	26,660	278
OJUM-01-50	+0.050 +0.150	12,500	10,750	6,125	87,500	75,265	42,875	479



⁷⁸⁾ According to igus® testing method ▶ Page 1210

⁸²⁾ Design standards ▶ Page 1209

Please note: Installation instructions ▶ Page 1212

J200 - for Aluminum shafting

A180 - FDA compliant

X - High temperature and chemical resistance

E7 - for steel and stainless steel shafting

Can be combined with:



RQA-01



RTA-01



RGA-01



RGAS-01

Available with drylin® liners



E7



X

- X liner optional for chemicals/high temps up to +482°F (+250°C) for steel housing, up to +356°F (+180°C) for aluminum

Optional



J200



A180

drylin® R linear plain bearings | Product Range

Open, anodized aluminum adapter, self-aligning - iglide® J liner

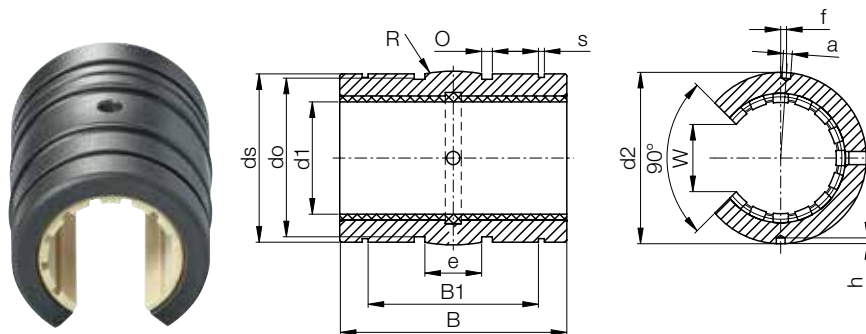

Order key

Size				Size
O	J	U	M	-03-10
Open	iglide® J	Liner	Metric	Self-aligning
				Inner Ø d1

- With reduced outer diameter, spherical area on the outer diameter, O-rings for elastic seating and hard anodized surface
- Dimensionally interchangeable with linear ball bearings

Dimensions [mm]

Part No.	d1	d2	ds	e	o	do	B1	s	B	R	W	a	f	h
		h7	h10		+0.1		H10	H10	h10		-1	+0.1	±0.2	-0.5
OJUM-03-10	10	18.8	18.5	5.0	1.86	15.4	21.8	1.30	28.9	13.0	7.3	0.0	0	1.2
OJUM-03-12	12	21.8	21.5	6.0	1.86	18.4	22.8	1.30	31.9	18.0	9.0	3.0	1.33 (7°)	1.2
OJUM-03-16	16	25.8	25.5	8.0	2.86	20.4	24.9	1.30	35.9	32.0	11.6	2.2	0	1.2
OJUM-03-20	20	31.8	31.5	10.0	2.86	26.4	31.5	1.60	44.8	50.0	12.0	2.2	0	1.2
OJUM-03-25	25	39.8	39.0	12.5	2.86	34.4	44.1	1.85	57.8	39.0	14.5	3.0	-1.5 (-4.3°)	1.5
OJUM-03-30	30	46.7	46.0	15.0	2.86	41.4	52.1	1.85	67.8	57.0	16.6	3.0	2 (4.9°)	2
OJUM-03-40	40	61.7	61.0	20.0	2.86	56.4	60.9	2.15	79.8	100.0	21.0	3.0	1.5 (2.8°)	2
OJUM-03-50	50	74.7	74.0	25.0	2.86	69.4	78.0	2.65	99.8	157.0	25.5	5.0	2.5 (3.8°)	2

Technical Data

Part No.	Housing bore Ø H7 [mm]	d1-Tolerance ⁷⁸⁾	F max. [N] dynamic ⁸²⁾ P = 5 MPa			F max. [N] static ⁸²⁾ P = 35 MPa			Weight [g]
			0°	90°	180°	0°	90°	180°	
OJUM-03-10	19	+0.030 +0.088	725	500	196	5,075	3,500	1370	10
OJUM-03-12	22	+0.030 +0.088	960	635	240	6,720	4,445	1,680	13
OJUM-03-16	26	+0.030 +0.088	1,440	990	396	10,080	6,943	2,772	19
OJUM-03-20	32	+0.030 +0.091	2,250	1,800	900	15,750	12,600	6,300	38
OJUM-03-25	40	+0.030 +0.091	3,625	2,953	1,523	25,375	20,670	10,658	63
OJUM-03-30	47	+0.040 +0.110	5,100	4,250	2,278	35,700	29,735	15,946	119
OJUM-03-40	62	+0.040 +0.115	8,000	6,810	3,800	56,000	47,660	26,600	250
OJUM-03-50	75	+0.050 +0.150	12,500	10,750	6,125	87,500	75,265	42,875	431

J200 - for Aluminum shafting

A180 - FDA compliant

X - High temperature and chemical resistance

E7 - for steel and stainless steel shafting



⁷⁸⁾ According to igus® testing method ▶ Page 1210

⁸²⁾ Design standards ▶ Page 1209

Please note: Installation instructions ▶ Page 1212

Can be combined with:



RQA-03



RTA-03



RGA-03



RGAS-03



E7



X

Available with drylin® liners

- X liner optional for chemicals/high temps up to +482°F (+250°C) for steel housing, up to +356°F (+180°C) for aluminum

Optional



J200



A180

drylin® R pillow blocks | Product Range

Closed, anodized aluminum housing, short - iglide® J liner

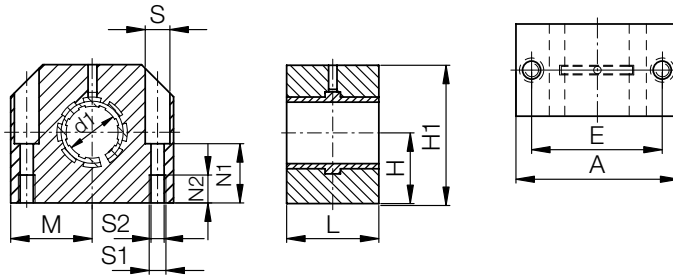

Order key

Size					Size
R	J	U	M	-05-10	
Closed	iglide® J	Liner	Metric	Compact	Inner Ø d1

Dimensions [mm]

Part No.	d1	H +0.01 -0.014	H1	A	M	E ±0.15	S	S1	S2	N1	N2	L
RJZM-05-08 ^{en)}	8	14	27	32	16.0	23	6.0	M4	3.4	13	9	24
RJUM-05-10	10	16	33	40	20.0	29	8.0	M5	4.3	16	11	26
RJUM-05-12	12	17	33	40	20.0	29	8.0	M5	4.3	16	11	28
RJUM-05-16	16	19	38	45	22.5	34	8.0	M5	4.3	18	11	30
RJUM-05-20	20	23	45	53	26.5	40	9.5	M6	5.3	22	13	30
RJUM-05-25	25	27	54	62	31.0	48	11.0	M8	6.6	26	18	40
RJUM-05-30	30	30	60	67	33.5	53	11.0	M8	6.6	29	18	50
RJUM-05-40	40	39	76	87	43.5	69	15.0	M10	8.4	38	22	60
RJUM-05-50	50	47	92	103	51.5	82	18.0	M12	10.5	46	26	70

Technical Data

Part No.	d1-Tolerance ⁷⁸⁾ [mm]	F max, dynamic ⁸²⁾ P = 5 MPa [N]	F max, static ⁸²⁾ P = 35 MPa [N]	Weight [g]
RJZM-05-08 ^{en)}	+0.032 +0.070	960	6,720	46
RJUM-05-10	+0.030 +0.088	650	4,550	71
RJUM-05-12	+0.030 +0.088	840	5,880	78
RJUM-05-16	+0.030 +0.088	1,200	8,400	106
RJUM-05-20	+0.030 +0.091	1,500	10,500	132
RJUM-05-25	+0.030 +0.091	2,500	17,500	253
RJUM-05-30	+0.040 +0.110	3,750	26,250	374
RJUM-05-40	+0.040 +0.115	6,000	42,000	713
RJUM-05-50	+0.050 +0.150	8,750	61,250	1,168



⁷⁸⁾ According to igus® testing method ► Page 1210

⁸²⁾ Design standards ► Page 1209

Please note: Installation instructions ► Page 1212

J200 - for Aluminum shafting

A180 - FDA compliant

X - High temperature and chemical resistance

E7 - for steel and stainless steel shafting

Available with drylin® liners



E7



X

- X liner optional for chemicals/high temps up to +482°F (+250°C) for steel housing, up to +356°F (+180°C) for aluminum

Optional



J200



A180

drylin® R pillow blocks | Product Range

Adjustable, anodized aluminum housing, short - iglide® J liner

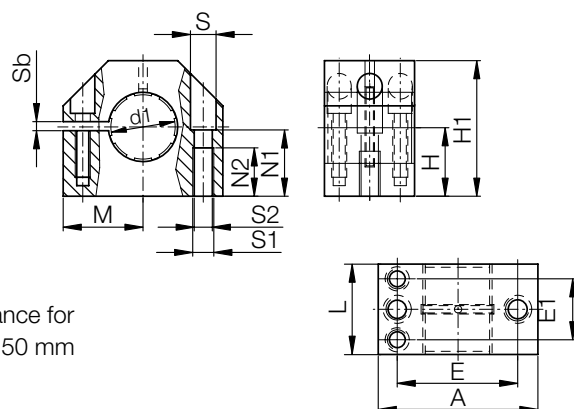

- With adjustable clearance for shaft diameters 12 to 50 mm



Order key

Type	Size
R J U M E -05-12	
Closed	iglide® J
Liner	Metric
Adjustable	Compact
Inner Ø d1	

Dimensions [mm]

Part No.	d1	H +0.01 -0.014	H1	A	M	E ±0.15	E1 ±0.15	S	S1	S2	Sb	N1	N2	L
RJUME-05-12	12	17	33	40	20.0	29	18.0	8.0	4.3	M5	2	16	11	28
RJUME-05-16	16	19	38	45	22.5	34	19.0	8.0	4.3	M5	2	18	11	30
RJUME-05-20	20	23	45	53	26.5	40	20.0	9.5	5.3	M6	2	22	13	30
RJUME-05-25	25	27	54	62	31.0	48	25.5	11.0	6.6	M8	2	26	18	40
RJUME-05-30	30	30	60	67	33.5	53	30.5	11.0	6.6	M8	2	29	18	50
RJUME-05-40	40	39	76	87	43.5	69	36.0	15.0	8.4	M10	2	38	22	60
RJUME-05-50	50	47	92	103	51.5	82	44.0	18.0	10.5	M12	2	46	26	70

Technical Data

Part No.	d1-Tolerance™ [mm]	F max. dynamic ⁷⁸ P = 5 MPa [N]	F max. static ⁸⁰ P = 35 MPa [N]	Weight [g]
RJUME-05-12	adjustable	840	5,880	78
RJUME-05-16	adjustable	1,200	8,400	106
RJUME-05-20	adjustable	1,500	10,500	132
RJUME-05-25	adjustable	2,500	17,500	253
RJUME-05-30	adjustable	3,750	26,250	374
RJUME-05-40	adjustable	6,000	42,000	713
RJUME-05-50	adjustable	8,750	61,250	1,168



⁷⁸ According to igus® testing method ▶ Page 1210

⁸⁰ Design standards ▶ Page 1209

Please note: Installation instructions ▶ Page 1212

J200 - for Aluminum shafting

A180 - FDA compliant

X - High temperature and chemical resistance

E7 - for steel and stainless steel shafting

Available with drylin® liners



E7



X

- X liner optional for chemicals/high temps up to +482°F (+250°C) for steel housing, up to +356°F (+180°C) for aluminum

Optional



J200



A180

drylin® R pillow blocks | Product Range

Split, anodized aluminum housing, short - iglide® J liner

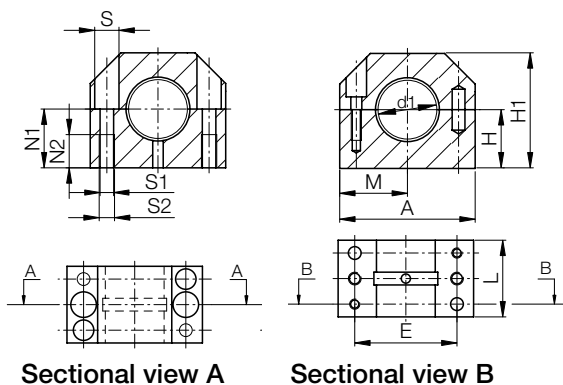
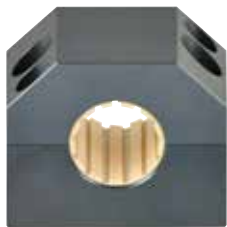

Order key

Size	Size
T J U M-05-16	
Split	Inner Ø d1
iglide® J	
Liner	
Metric	
Compact	

- Replacement of the liner is possible without removing the shaft

Dimensions [mm]

Part No.	d1	H ±0.02	H1	A	M	E ±0.15	S	S1	S2	N1	N2	L
TJUM-05-16	16	19	38	45	22.5	34	8.0	M5	4.3	18	11	30
TJUM-05-20	20	23	45	53	26.5	40	9.5	M6	5.3	22	13	30
TJUM-05-25	25	27	54	62	31.0	48	11.0	M8	6.6	26	18	40
TJUM-05-30	30	30	60	67	33.5	53	11.0	M8	6.6	29	18	50
TJUM-05-40	40	39	76	87	43.5	69	15.0	M10	8.4	38	22	60

Technical Data

Part No.	d1-Tolerance ⁷⁸⁾ [mm]	F max. dynamic ⁸²⁾ P = 5 MPa [N]		F max. static ⁸²⁾ P = 35 MPa [N]	Weight [g]
TJUM-05-16	+0.030 +0.120		1,200	8,400	105
TJUM-05-20	+0.030 +0.120		1,500	10,500	137
TJUM-05-25	+0.030 +0.120		2,500	17,500	253
TJUM-05-30	+0.040 +0.135		3,750	26,250	377
TJUM-05-40	+0.040 +0.135		6,000	42,000	720



⁷⁸⁾ According to igus® testing method ► Page 1210

⁸²⁾ Design standards ► Page 1209

Please note: Installation instructions ►► Page 1212

J200 - for Aluminum shafting

A180 - FDA compliant

X - High temperature and chemical resistance

E7 - for steel and stainless steel shafting

Available with drylin® liners



E7



X

- X liner optional for chemicals/high temps up to +482°F (+250°C) for steel housing, up to +356°F (+180°C) for aluminum

Optional



J200



A180

drylin® R pillow blocks | Product Range

Closed, anodized aluminum housing, short twin - iglide® J liner

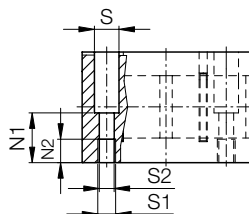
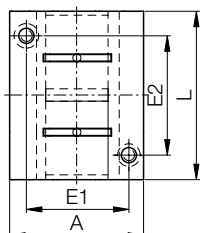
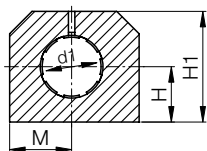

- Twin design
- Equipped with 2 JUM-02 liners to increase the guide length



Order key

Type						Size
R J U M T -05-12						
Closed	iglide® J	Liner	Metric	Tandem	Compact	Inner Ø d1

Dimensions [mm]

Part No.	d1	H +0.01 -0.014	H1	A	M	E1 ±0.15	E2 ±0.15	S	S1	S2	N1	N2	L
RJUMT-05-12	12	17	33	40	20	29	35	8.0	M5	4.3	16.0	11	60
RJUMT-05-16	16	19	38	45	22.5	34	40	8.0	M5	4.3	18.0	11	65
RJUMT-05-20	20	23	45	53	26.5	40	45	9.5	M6	5.3	22.0	13	65
RJUMT-05-25	25	27	54	62	31	48	55	11.0	M8	6.6	26.0	18	85
RJUMT-05-30	30	30	60	67	33.5	53	70	11.0	M8	6.6	29.0	18	105
RJUMT-05-40	40	39	76	87	43.5	69	85	15.0	M10	8.4	38.0	22	125
RJUMT-05-50 ⁸⁴⁾	50	47	92	103	51.5	82	100	18.0	M12	10.5	46.0	26	145

Technical Data

Part No.	d1-Tolerance ⁷⁸⁾ [mm]	F max. dynamic ⁸²⁾ P = 5 MPa [N]		F max. static ⁸²⁾ P = 35 MPa [N]	Weight [g]
RJUMT-05-12	+0.030 +0.088	840		5,880	170
RJUMT-05-16	+0.030 +0.088	1,200		8,400	250
RJUMT-05-20	+0.030 +0.091	1,500		10,500	300
RJUMT-05-25	+0.030 +0.091	2,500		17,500	550
RJUMT-05-30	+0.040 +0.110	3,750		26,250	750
RJUMT-05-40	+0.040 +0.115	6,000		42,000	1,500
RJUMT-05-50 ⁸⁴⁾	+0.050 +0.150	8,750		61,250	2,400



⁷⁸⁾ According to igus® testing method ► Page 1210

⁸²⁾ Design standards ► Page 1209

Please note: Installation instructions ►► Page 1212

J200 - for Aluminum shafting

A180 - FDA compliant

X - High temperature and chemical resistance

E7 - for steel and stainless steel shafting

Available with drylin® liners



E7



X

- X liner optional for chemicals/high temps up to +482°F (+250°C) for steel housing, up to +356°F (+180°C) for aluminum

Optional



J200



A180

drylin® R pillow blocks | Product Range

Closed, anodized aluminum housing, long - iglide® J liner

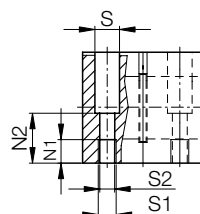
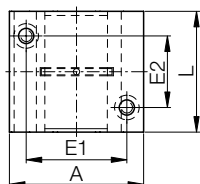
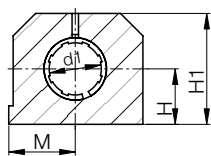

Order key

Size					Size
R	J	U	M	-06-	16
Closed	iglide® J	Liner	Metric	Long design	Inner Ø d1



⁷⁸⁾ According to igus® testing method ▶ Page 1210

⁸²⁾ Design standards ▶ Page 1209

Please note: Installation instructions ▶ Page 1212

Dimensions [mm]

Part No.	d1	H	H1	A	M	E1	E2	S	S1	S2	N1	N2	L
		+0.01 -0.014				±0.15	±0.15						
RJUM-06-12	12	18	35	43	21.5	32	23	8.0	M5	4.3	16.5	11	39
RJUM-06-16	16	22	42	53	26.5	40	26	10.0	M6	5.3	21.0	13	43
RJUM-06-20	20	25	50	60	30.0	45	32	11.0	M8	6.6	24.0	18	54
RJUM-06-25	25	30	60	78	39.0	60	40	15.0	M10	8.4	29.0	22	67
RJUM-06-30	30	35	70	87	43.5	68	45	15.0	M10	8.4	34.0	22	79
RJUM-06-40	40	45	90	108	54.0	86	58	18.0	M12	10.5	44.0	26	91
RJUM-06-50	50	50	105	132	66.0	108	50	20.0	M16	13.5	49.0	34	113

Technical Data

Part No.	d1-Tolerance ⁷⁸⁾	F max. dynamic ⁸²⁾	F max. static ⁸²⁾	Weight
	[mm]	P = 5 MPa [N]	P = 35 MPa [N]	
RJUM-06-12	+0.030 +0.088	960	6,720	121
RJUM-06-16	+0.030 +0.088	1,440	10,080	211
RJUM-06-20	+0.030 +0.091	2,250	15,750	323
RJUM-06-25	+0.030 +0.091	3,625	25,375	651
RJUM-06-30	+0.040 +0.110	5,100	35,700	1,050
RJUM-06-40	+0.040 +0.115	8,000	56,000	1,820
RJUM-06-50	+0.050 +0.150	12,500	87,500	3,250

J200 - for Aluminum shafting

A180 - FDA compliant

X - High temperature and chemical resistance

E7 - for steel and stainless steel shafting

Available with drylin® liners



E7



X

● X liner optional for chemicals/high temps up to +482°F (+250°C) for steel housing, up to +356°F (+180°C) for aluminum

Optional



J200



A180

drylin® R pillow blocks | Product Range

Closed, anodized aluminum housing, long, manual clamp - iglide® J liner

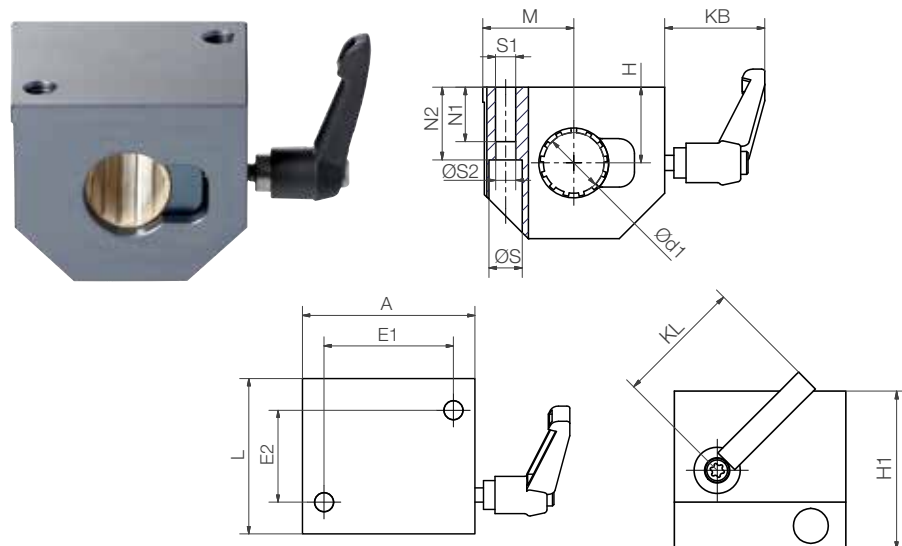

Order key

Type Size Option

R J U M -06-12 - HK

Closed	iglide® J	Liner	Metric	Long design	Inner Ø d1	Manual clamp
--------	-----------	-------	--------	-------------	------------	--------------

Dimensions [mm]

Part No.	d1	H	H1	A	M	E1	E2	S	S1	S2	N1	N2	W	L	KL	KB
		+0.01; -0.014			±0.02	±0.15	±0.15							-1		
RJUM-06-12-HK	12	18	35	43	21.5	32	23	8	M5	4.3	16.5	11	10.2	39	40	33
RJUM-06-16-HK	16	22	42	53	26.5	40	26	10	M6	5.3	21	13	11.6	43	40	33
RJUM-06-20-HK	20	25	50	60	30	45	32	11	M8	6.6	24	18	12	54	40	33
RJUM-06-25-HK	25	30	60	78	39	60	40	15	M10	8.4	29	22	14.5	67	65	46
RJUM-06-30-HK	30	35	70	87	43.5	68	45	15	M10	8.4	34	22	16.6	79	65	46
RJUM-06-40-HK	40	45	90	108	54	86	58	18	M12	10.5	44	26	21	91	65	46
RJUM-06-50-HK	50	50	105	132	66	108	50	20	M16	13.5	49	34	25.5	113	65	46

Technical Data

Part No.	d1 tolerance ⁷⁸⁾	Fmax. dynamic ⁸²⁾		Fmax. static ⁸²⁾		Clamp force axial [N]	Weight [g]
		p = 5MPa		p = 35MPa			
		0°		0°			
RJUM-06-12-HK	+0.030 +0.088	960		6720		400	0.098
RJUM-06-16-HK	+0.030 +0.088	1440		10080		400	0.164
RJUM-06-20-HK	+0.030 +0.091	2250		15750		400	0.275
RJUM-06-25-HK	+0.030 +0.091	3625		25375		1,000	0.544
RJUM-06-30-HK	+0.040 +0.110	5100		35700		1,000	0.832
RJUM-06-40-HK	+0.040 +0.115	8000		56000		1,000	1.513
RJUM-06-50-HK	+0.050 +0.150	12500		87500		1,000	2.568



⁷⁸⁾ According to igus® testing method ► Page 1210

⁸²⁾ Design standards ► Page 1209

Please note: Installation instructions ► Page 1212

J200 - for Aluminum shafting

A180 - FDA compliant

X - High temperature and chemical resistance

E7 - for steel and stainless steel shafting

Available with drylin® liners



E7



X

- X liner optional for chemicals/high temps up to +482°F (+250°C) for steel housing, up to +356°F (+180°C) for aluminum

Optional



J200



A180

drylin® R pillow blocks | Product Range

Closed, anodized aluminum, floating pillow block - iglide® J liner

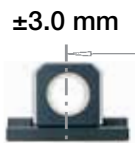
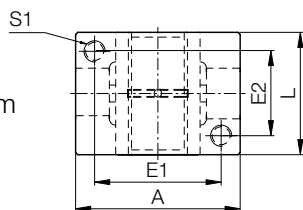
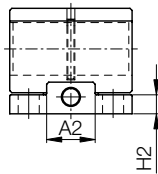
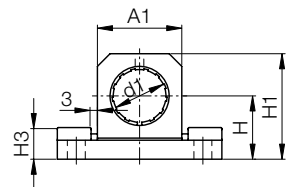

- Compensation of parallelism errors up to 6 mm
- Quick assembly on raw profiles



Order key

Type Size Option

R J U M - 06 - 12 - LL

Closed	iglide® J	Liner	Metric	Long design	Inner Ø d1	Floating bearing
--------	-----------	-------	--------	-------------	------------	------------------

Dimensions [mm]

Part No.	d1	H	H1	A	E1	E2	S1	L	A1	A2	H2	H3
		±0.01			±0.15	±0.15						
RJUM-06-12 LL	12	18	28	43	32	23	M5	32	20	13	6	11
RJUM-06-16 LL	16	22	35	53	40	26	M6	36	26	15	7	11
RJUM-06-20 LL	20	25	41	60	45	32	M8	45	32	19	7	12.5
RJUM-06-25 LL	25	30	50	78	60	40	M10	58	40	23	9	15
RJUM-06-30 LL	30	35	59	87	68	45	M10	68	48	28	10	15
RJUM-06-40 LL	40	45	76	108	86	58	M12	80	62	80	20	20
RJUM-06-50 LL	50	50	89	132	108	50	M16	100	78	100	24	24

Technical Data

Part No.	d1-Tolerance ⁷⁸ [mm]	F max. static or dynamic ⁸² [N]	Weight [g]
RJUM-06-12 LL	+0.030 +0.088	560	50
RJUM-06-16 LL	+0.030 +0.088	920	80
RJUM-06-20 LL	+0.030 +0.091	2,100	130
RJUM-06-25 LL	+0.030 +0.091	3,550	280
RJUM-06-30 LL	+0.040 +0.110	5,300	430
RJUM-06-40 LL	+0.040 +0.115	8,000	850
RJUM-06-50 LL	+0.050 +0.150	12,500	1,550



⁷⁸ According to igus® testing method ▶ Page 1210

⁸² Design standards ▶ Page 1209

Please note: Installation instructions ▶ Page 1212

Floating bearing ▶ Page 1209

J200 - for Aluminum shafting

A180 - FDA compliant

X - High temperature and chemical resistance

E7 - for steel and stainless steel shafting

Available with drylin® liners



E7



X

- X liner optional for chemicals/high temps up to +482°F (+250°C) for steel housing, up to +356°F (+180°C) for aluminum

Optional



J200



A180

drylin® R pillow blocks | Product Range

Open, anodized aluminum, floating pillow block - iglide® J liner



- Compensation of parallelism errors up to 6 mm

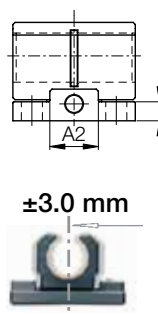
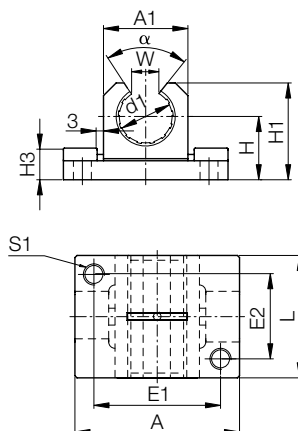

Order key

Type Size Option

O J U M-06-12-LL

Open	iglide® J	Liner	Metric	Long design	Inner Ø d1	Floating bearing
------	-----------	-------	--------	-------------	------------	------------------

Dimensions [mm]

Part No.	d1	H ±0.01	H1	A	E1 ±0.15	E2 ±0.15	S1	L	A1	A2	H2	H3	W -1	α [°]
OJUM-06-12 LL	12	18	24.5	43	32	23	M5	32	20	13	6	11	10.2	90
OJUM-06-16 LL	16	22	30.5	53	40	26	M6	36	26	15	7	11	11.6	90
OJUM-06-20 LL	20	25	37.0	60	45	32	M8	45	32	19	7	12.5	12.0	60
OJUM-06-25 LL	25	30	44.0	78	60	40	M10	58	40	23	9	15	14.5	60
OJUM-06-30 LL	30	35	52.5	87	68	45	M10	68	48	28	10	15	16.8	60
OJUM-06-40 LL	40	45	69.0	108	86	58	M12	80	62	80	20	20	21.0	60
OJUM-06-50 LL	50	50	80.0	132	108	50	M16	100	78	100	24	24	25.5	60

Technical Data

Part No.	d1-Tolerance ⁷⁸	F max. static or dynamic ⁸²	F max. dynamic load at 180° ⁸²	Weight
	[mm]	[N]	[N]	[g]
OJUM-06-12 LL	+0.030 +0.088	560	240	40
OJUM-06-16 LL	+0.030 +0.088	920	400	70
OJUM-06-20 LL	+0.030 +0.091	2,100	900	115
OJUM-06-25 LL	+0.030 +0.091	3,550	1,520	240
OJUM-06-30 LL	+0.040 +0.110	5,100	2,280	370
OJUM-06-40 LL	+0.040 +0.115	8,000	3,800	750
OJUM-06-50 LL	+0.050 +0.150	12,500	6,100	1,400

⁷⁸ According to igus® testing method ► Page 1210⁸² Design standards ► Page 1209

Please note: Installation instructions ► Page 1212

Floating bearing ► Page 1209

J200 - for Aluminum shafting

A180 - FDA compliant

X - High temperature and chemical resistance

E7 - for steel and stainless steel shafting

Available with drylin® liners



E7



X

- X liner optional for chemicals/high temps up to +482°F (+250°C) for steel housing, up to +356°F (+180°C) for aluminum

Optional



J200



A180

drylin® R pillow blocks | Product Range

Open, anodized aluminum housing, long - iglide® J liner

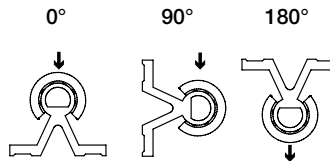
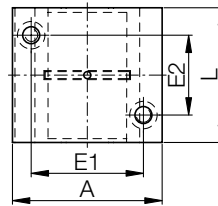
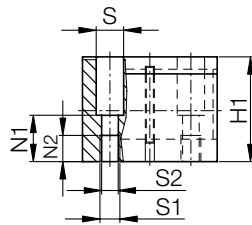
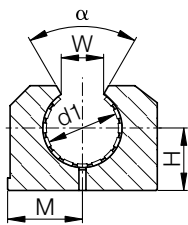

Order key

Size

O J U M -06-10

Open	iglide® J	Liner	Metric	Long design	Inner Ø d1
------	-----------	-------	--------	-------------	------------

Dimensions [mm]

Part No.	d1	H	H1	A	M	E1	E2	S	S1	S2	N1	N2	W	α	L
	+0.01; -0.014					±0.15	±0.15						-1	[°]	
OJUM-06-12	12	18	28	43	21.5	32	23	8.0	M5	4.3	16.5	11	10.2	78	39
OJUM-06-16	16	22	35	53	26.5	40	26	10.0	M6	5.3	21.0	13	11.6	78	43
OJUM-06-20	20	25	42	60	30.0	45	32	11.0	M8	6.6	24.0	18	12.0	60	54
OJUM-06-25	25	30	51	78	39.0	60	40	15.0	M10	8.4	29.0	22	14.5	60	67
OJUM-06-30	30	35	60	87	43.5	68	45	15.0	M10	8.4	34.0	22	16.6	57	79
OJUM-06-40	40	45	77	108	54.0	86	58	18.0	M12	10.5	44.0	26	21.0	56	91
OJUM-06-50	50	50	88	132	66.0	108	50	20.0	M16	13.5	49.0	34	25.5	54	113

Technical Data

Part No.	d1-Tolerance ⁷⁸⁾ [mm]	F max. Dynamic ⁸²⁾ Load [N] P = 5 MPa			F max. Static ⁸²⁾ Load [N] P = 35 MPa			Weight [g]
		0°	90°	180°	0°	90°	180°	
		OJUM-06-12	+0.030 +0.088	960	635	240	6,720	
OJUM-06-16	+0.030 +0.088	1440	990	396	10,080	6,943	2,772	158
OJUM-06-20	+0.030 +0.091	2250	1,800	900	15,750	12,600	6,300	266
OJUM-06-25	+0.030 +0.091	3625	2,953	1,523	25,375	20,670	10,658	530
OJUM-06-30	+0.040 +0.110	5100	4,250	2,278	35,700	29,735	15,946	818
OJUM-06-40	+0.040 +0.115	8000	6,810	3,800	56,000	47,660	26,600	1,485
OJUM-06-50	+0.050 +0.150	12,500	10,750	6,125	87,500	75,265	42,875	2,750



⁷⁸⁾ According to igus® testing method ▶ Page 1210

⁸²⁾ Design standards ▶ Page 1209

Please note: Installation instructions ▶ Page 1212

J200 - for Aluminum shafting

A180 - FDA compliant

X - High temperature and chemical resistance

E7 - for steel and stainless steel shafting

Available with drylin® liners



E7



X

● X liner optional for chemicals/high temps up to +482°F (+250°C) for steel housing, up to +356°F (+180°C) for aluminum

Optional



J200



A180

drylin® R pillow blocks | Product Range

Closed, anodized aluminum housing, long with manual clamp - iglide® J

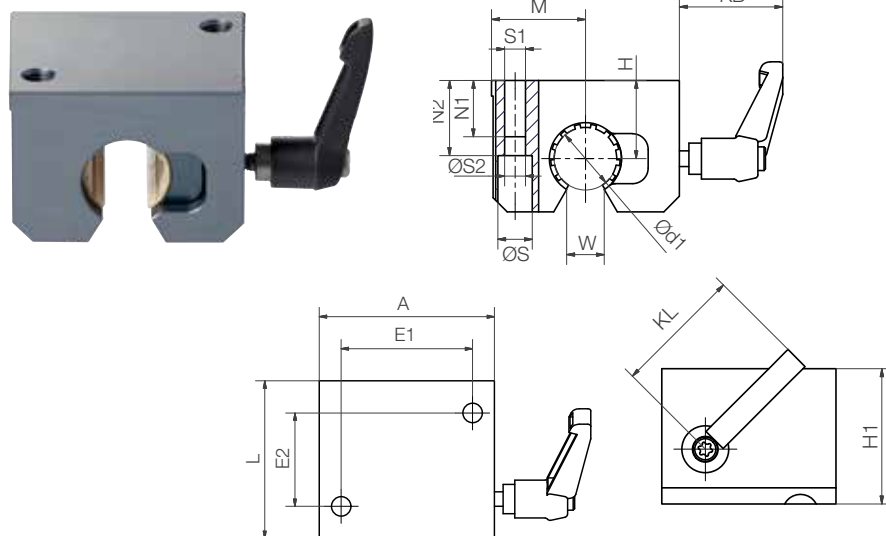

Order key

Size **O J U M-06-10-HK** Size Option

Open	iglide® J	Liner	Metric	Long design	Inner Ø d1	Manual clamp
------	-----------	-------	--------	-------------	------------	--------------

Dimensions [mm]

Part No.	d1	H	H1	A	M	E1	E2	S	S1	S2	N1	N2	W	L	KL	KB
		+0.01; -0.014			±0.02	±0.15	±0.15							-1		
OJUM-06-12-HK	12	18	35	43	21.5	32	23	8	M5	4.3	16.5	11	10.2	39	40	33
OJUM-06-16-HK	16	22	42	53	26.5	40	26	10	M6	5.3	21	13	11.6	43	40	33
OJUM-06-20-HK	20	25	50	60	30.0	45	32	11	M8	6.6	24	18	12.0	54	40	33
OJUM-06-25-HK	25	30	60	78	39.0	60	40	15	M10	8.4	29	22	14.5	67	65	46
OJUM-06-30-HK	30	35	70	87	43.5	68	45	15	M10	8.4	34	22	16.6	79	65	46
OJUM-06-40-HK	40	45	90	108	54.0	86	58	18	M12	10.5	44	26	21.0	91	65	46
OJUM-06-50-HK	50	50	105	132	66.0	108	50	20	M16	13.5	49	34	25.5	113	65	46

Technical Data

Part No.	d1 tolerance ⁷⁸⁾	Fmax. dynamic ⁸²⁾			Fmax. static ⁸³⁾			Clamp force axial [N]	Weight [g]
		p = 5MPa			p = 35MPa				
		0°	90°	180°	0°	90°	180°		
OJUM-06-12-HK	+0.030 +0.088	960	635	240	6720	4445	1680	400	0.098
OJUM-06-16-HK	+0.030 +0.088	1440	990	396	10080	6943	2772	400	0.164
OJUM-06-20-HK	+0.030 +0.091	2250	1800	900	15750	12600	6300	400	0.275
OJUM-06-25-HK	+0.030 +0.091	3625	2953	1523	25375	20670	10658	1,000	0.544
OJUM-06-30-HK	+0.040 +0.110	5100	4250	2278	35700	29735	15946	1,000	0.832
OJUM-06-40-HK	+0.040 +0.115	8000	6810	3800	56000	47660	26600	1,000	1.513
OJUM-06-50-HK	+0.050 +0.150	12500	10750	6125	87500	75265	42875	1,000	2.568



⁷⁸⁾ According to igus® testing method ► Page 1210

⁸²⁾ Design standards ► Page 1209

Please note: Installation instructions ► Page 1212

J200 - for Aluminum shafting

A180 - FDA compliant

X - High temperature and chemical resistance

E7 - for steel and stainless steel shafting

Available with drylin® liners



E7



X

- X liner optional for chemicals/high temps up to +482°F (+250°C) for steel housing, up to +356°F (+180°C) for aluminum

Optional



J200



A180

drylin® R pillow blocks | Product Range

Subheading

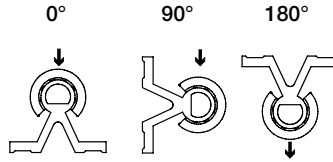
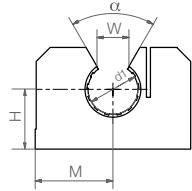
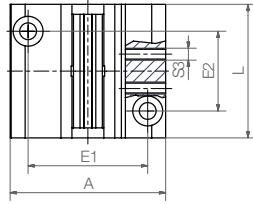
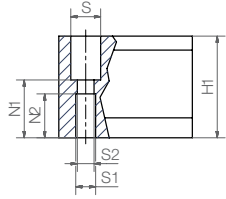

Order key

Type O J U M E -06-10 Size

O J U M E -06-10

Open	iglide® J	Liner	Metric	Adjustable	Long design	Inner Ø d1
------	-----------	-------	--------	------------	-------------	------------

- With two set screws (DIN 913), adjustable clearance

Dimensions [mm]

Part No.	d1	H	H1	A	M	E1	E2	S	S1	S2	S3	N1	N2	W	α	L
OJUME-06-12	12	18	28	43	21.5	32	23	8.0	M5	4.3	M4	16.5	11	10.2	78	39
OJUME-06-16	16	22	35	53	26.5	40	26	10.0	M6	5.3	M4	21.0	13	11.6	78	43
OJUME-06-20	20	25	42	60	30.0	45	32	11.0	M8	6.6	M5	24.0	18	12.0	60	54
OJUME-06-25	25	30	51	78	39.0	60	40	15.0	M10	8.4	M6	29.0	22	14.5	60	67
OJUME-06-30	30	35	60	87	43.5	68	45	15.0	M10	8.4	M6	34.0	22	16.6	57	79
OJUME-06-40	40	45	77	108	54.0	86	58	18.0	M12	10.5	M8	44.0	26	21.0	56	91
OJUME-06-50	50	50	88	132	66.0	108	50	20.0	M16	13.5	M8	49.0	34	25.5	54	113

Technical Data

Part No.	d1-Tolerance ⁷⁸ [mm]	F max. Dynamic ⁸² Load [N] P = 5 MPa			F max. Static ⁸² Load [N] P = 35 MPa			Weight [g]			
		0°	90°	180°	0°	90°	180°				
		OJUME-06-12	adjustable	960	635	240	6,720		4,445	1,680	100
		OJUME-06-16	adjustable	1,440	990	396	10,080		6,943	2,772	160
OJUME-06-20	adjustable	2,250	1,800	900	15,750	12,600	6,300	270			
OJUME-06-25	adjustable	3,625	2,953	1,523	25,375	20,670	10,658	530			
OJUME-06-30	adjustable	5,100	4,250	2,278	35,700	29,735	15,946	820			
OJUME-06-40	adjustable	8,000	6,810	3,800	56,000	47,660	26,600	1,490			
OJUME-06-50	adjustable	12,500	10,750	6,125	87,500	75,265	42,875	2,750			



⁷⁸ According to igus® testing method ► Page 1210

⁸² Design standards ► Page 1209

Please note: Installation instructions ► Page 1212

J200 - for Aluminum shafting

A180 - FDA compliant

X - High temperature and chemical resistance

E7 - for steel and stainless steel shafting

Available with drylin® liners



E7



X

- X liner optional for chemicals/high temps up to +482°F (+250°C) for steel housing, up to +356°F (+180°C) for aluminum

Optional



J200



A180

drylin® R pillow blocks | Product Range

Closed, anodized aluminum adapter, round flange - iglide® J liner

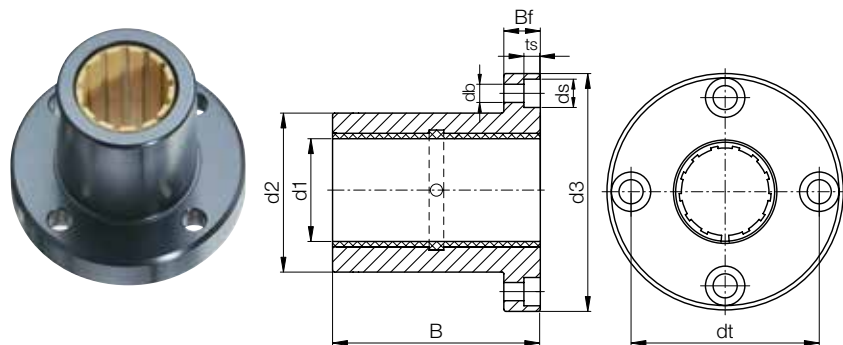

Type	Size	Option
F J U M -01 -10 - LL		
Flange	iglide® J	Liner
Metric	Round	Inner Ø d1
		Floating bearing



⁷⁸⁾ According to igus® testing method ▶ Page 1210

⁸²⁾ Design standards ▶ Page 1209

Please note: Installation instructions ▶ Page 1212

Dimensions [mm]

Part No.	d1	d2 h7	d3	dt	B	Bf	ts	db	ds
FJZM-01-08 - <input type="checkbox"/>	8	16	32	24	25	8	3.1	3.5	6.0
FJUM-01-10 - <input type="checkbox"/>	10	19	39	29	29	9	4.1	4.5	7.5
FJUM-01-12 - <input type="checkbox"/>	12	22	42	32	32	9	4.1	4.5	7.5
FJUM-01-16 - <input type="checkbox"/>	16	26	46	36	36	9	4.1	4.5	7.5
FJUM-01-20 - <input type="checkbox"/>	20	32	54	43	45	11	5.1	5.5	9.0
FJUM-01-25 - <input type="checkbox"/>	25	40	62	51	58	11	5.1	5.5	9.0
FJUM-01-30 - <input type="checkbox"/>	30	47	76	62	68	14	6.1	6.6	11.0
FJUM-01-40 - <input type="checkbox"/>	40	62	98	80	80	18	8.1	9.0	14.0
FJUM-01-50 - <input type="checkbox"/>	50	75	112	94	100	18	8.1	9.0	14.0

Technical Data

Part No.	d1-Tolerance ⁷⁸⁾ [mm]	F max. dynamic ⁸²⁾ P = 5 MPa [N]	F max. static ⁸²⁾ P = 35 MPa [N]	Weight [g]
FJZM-01-08 - <input type="checkbox"/>	+0.032 +0.070	960	6,720	20
FJUM-01-10 - <input type="checkbox"/>	+0.030 +0.088	725	5,075	32
FJUM-01-12 - <input type="checkbox"/>	+0.030 +0.088	960	6,720	42
FJUM-01-16 - <input type="checkbox"/>	+0.030 +0.088	1,440	10,080	51
FJUM-01-20 - <input type="checkbox"/>	+0.030 +0.091	2,250	15,750	88
FJUM-01-25 - <input type="checkbox"/>	+0.030 +0.091	3,625	25,375	152
FJUM-01-30 - <input type="checkbox"/>	+0.040 +0.110	5,100	35,700	266
FJUM-01-40 - <input type="checkbox"/>	+0.040 +0.115	8,000	56,000	552
FJUM-01-50 - <input type="checkbox"/>	+0.050 +0.150	12,500	87,500	853

For a floating version add the suffix -LL to the end of the part number
Example: FJUM - 01 -10 -LL for a floating version

J200 - for Aluminum shafting

A180 - FDA compliant

X - High temperature and chemical resistance

E7 - for steel and stainless steel shafting

Available with drylin® liners



E7



X

- X liner optional for chemicals/high temps up to +482°F (+250°C) for steel housing, up to +356°F (+180°C) for aluminum

Optional



J200



A180

drylin® R pillow blocks | Product Range

Closed, anodized aluminum, square flange - iglide® J liner

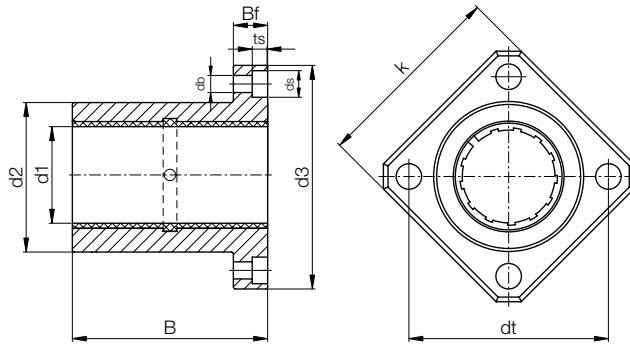

Order key

Type	Size	Option
F	J U M -02-10-	LL
Flange	iglide® J	Liner
	Metric	Square
	Inner Ø d1	Floating bearing



⁷⁸⁾ According to igus® testing method ▶ Page 1210

⁸²⁾ Design standards ▶ Page 1209

Please note: Installation instructions ▶ Page 1212

Dimensions [mm]

Part No.	d1	d2 h7	d3	dt	k	B	Bf	ts	db	ds
FJZM-02-08 - <input type="checkbox"/>	8	16	32	24	25	25	8	3.1	3.5	6.0
FJUM-02-10 - <input type="checkbox"/>	10	19	39	29	30	29	9	4.1	4.5	7.5
FJUM-02-12 - <input type="checkbox"/>	12	22	42	32	32	32	9	4.1	4.5	7.5
FJUM-02-16 - <input type="checkbox"/>	16	26	46	36	35	36	9	4.1	4.5	7.5
FJUM-02-20 - <input type="checkbox"/>	20	32	54	43	42	45	11	5.1	5.5	9.0
FJUM-02-25 - <input type="checkbox"/>	25	40	62	51	50	58	11	5.1	5.5	9.0
FJUM-02-30 - <input type="checkbox"/>	30	47	76	62	60	68	14	6.1	6.6	11.0
FJUM-02-40 - <input type="checkbox"/>	40	62	98	80	75	80	18	8.1	9.0	14.0
FJUM-02-50 - <input type="checkbox"/>	50	75	112	94	88	100	18	8.1	9.0	14.0

Technical Data

Part No.	d1-Tolerance ⁷⁸⁾ [mm]	F max. dynamic ⁸²⁾ P = 5 MPa [N]	F max. static ⁸²⁾ P = 35 MPa [N]	Weight [g]
FJZM-02-08 - <input type="checkbox"/>	+0.032 +0.070	960	6,720	17
FJUM-02-10 - <input type="checkbox"/>	+0.030 +0.088	725	5,075	25
FJUM-02-12 - <input type="checkbox"/>	+0.030 +0.088	960	6,720	32
FJUM-02-16 - <input type="checkbox"/>	+0.030 +0.088	1,440	10,080	41
FJUM-02-20 - <input type="checkbox"/>	+0.030 +0.091	2,250	15,750	73
FJUM-02-25 - <input type="checkbox"/>	+0.030 +0.091	3,625	25,375	135
FJUM-02-30 - <input type="checkbox"/>	+0.030 +0.110	5,100	35,700	228
FJUM-02-40 - <input type="checkbox"/>	+0.030 +0.115	8,000	56,000	454
FJUM-02-50 - <input type="checkbox"/>	+0.030 +0.150	12,500	87,500	735

For a floating version add the suffix -LL to the end of the part number
Example: FJUM - 02 -10 -LL for a floating version

J200 - for Aluminum shafting

A180 - FDA compliant

X - High temperature and chemical resistance

E7 - for steel and stainless steel shafting

Available with drylin® liners



E7



X

- X liner optional for chemicals/high temps up to +482°F (+250°C) for steel housing, up to +356°F (+180°C) for aluminum

Optional



J200



A180

drylin® R pillow blocks | Product Range

Closed, anodized aluminum, round flange, tandem design - iglide® J liner



Order key

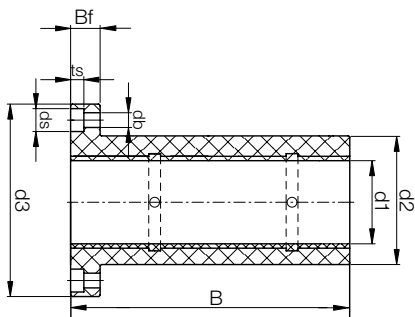
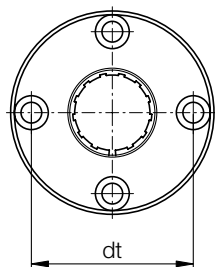

Type	Size	Option
F J U M T -01-10 - LL		
Flange	iglide® J	Liner
Metric	Tandem	Round
Inner Ø d1	Floating bearing	

- Equipped with two JUM-02 liners for increased guiding length



⁷⁸⁾ According to igus® testing method ▶ Page 1210
⁸⁵⁾ FJZMT-01-08 are fitted with 2 pieces of JSM-0810-16
 Please note: Installation instructions ▶ Page 1212

Dimensions [mm]

Part No.	d1	d2	d3	dt	B	Bf	ts	db	ds
FJZMT-01-08 ⁸⁵⁾ - □	8	16	32	24	45	8	3.1	3.5	6.0
FJUJMT-01-10 - □	10	19	39	29	52	9	4.1	4.5	7.5
FJUJMT-01-12 - □	12	22	42	32	57	9	4.1	4.5	7.5
FJUJMT-01-16 - □	16	26	46	36	70	9	4.1	4.5	7.5
FJUJMT-01-20 - □	20	32	54	43	80	11	5.1	5.5	9.0
FJUJMT-01-25 - □	25	40	62	51	112	11	5.1	5.5	9.0
FJUJMT-01-30 - □	30	47	76	62	123	14	6.1	6.6	11.0
FJUJMT-01-40 - □	40	62	98	80	151	18	8.1	9.0	14.0
FJUJMT-01-50 - □	50	75	112	94	192	18	8.1	9.0	14.0

Technical Data

Part No.	Nominal size	d1-Tolerance ⁷⁸⁾ [mm]	Effective surface area [mm]	Weight [g]
FJZMT-01-08 ⁸⁵⁾ - □	8	+0.032 +0.070	256	27,13
FJUJMT-01-10 - □	10	+0.030 +0.088	250	43,75
FJUJMT-01-12 - □	12	+0.030 +0.088	324	57,00
FJUJMT-01-16 - □	16	+0.030 +0.088	464	78,28
FJUJMT-01-20 - □	20	+0.030 +0.091	580	126,42
FJUJMT-01-25 - □	25	+0.030 +0.091	975	248,85
FJUJMT-01-30 - □	30	+0.030 +0.110	1,470	388,37
FJUJMT-01-40 - □	40	+0.030 +0.115	2,360	835,00
FJUJMT-01-50 - □	50	+0.030 +0.150	3,450	1352,30

For a floating version add the suffix -LL to the end of the part number
 Example: FJUJMT - 01 -10 -LL for a floating version

J200 - for Aluminum shafting
 A180 - FDA compliant
 X - High temperature and chemical resistance
 E7 - for steel and stainless steel shafting

Available with drylin® liners



E7



X

- X liner optional for chemicals/high temps up to +482°F (+250°C) for steel housing, up to +356°F (+180°C) for aluminum

Optional



J200



A180

drylin® R pillow blocks | Product Range

Closed, anodized aluminum, square flange, tandem design - iglide® J liner

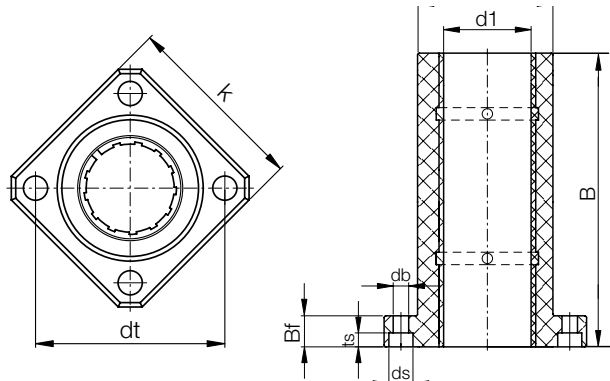

Type	Size	Option
F J U M T -02-10 - LL		
Flange	iglide® J	Liner
Metric	Tandem	Square
Inner Ø d1	Floating bearing	

- Equipped with two JUM-02 liners for increased guiding length



⁷⁸ According to igus® testing method ► Page 1210
⁸⁵ FJZMT-02-08 are fitted with 2 pieces of JSM-0810-16
 Please note: Installation instructions ► Page 1212

Dimensions [mm]

Part No.	d1	d2 h7	d3	dt	k	B	Bf	ts	db	ds
FJZMT-02-08 ⁸⁵	8	16	32	24	25	45	8	3.1	3.5	6.0
FJUMT-02-10-□	10	19	39	29	30	52	9	4.1	4.5	7.5
FJUMT-02-12-□	12	22	42	32	32	57	9	4.1	4.5	7.5
FJUMT-02-16-□	16	26	46	36	35	70	9	4.1	4.5	7.5
FJUMT-02-20-□	20	32	54	43	42	80	11	5.1	5.5	9.0
FJUMT-02-25-□	25	40	62	51	50	112	11	5.1	5.5	9.0
FJUMT-02-30-□	30	47	76	62	60	123	14	6.1	6.6	11.0
FJUMT-02-40-□	40	62	98	80	75	151	18	8.1	9.0	14.0
FJUMT-02-50-□	50	75	112	94	88	192	18	8.1	9.0	14.0

Technical Data

Part No.	Nominal size	d1-Tolerance ⁷⁸ [mm]	Effective surface area [mm]	Weight [g]
FJZMT-02-08-□	8	+0.032 +0.070	256	23,00
FJUMT-02-10-□	10	+0.030 +0.088	250	36,58
FJUMT-02-12-□	12	+0.030 +0.088	324	48,19
FJUMT-02-16-□	16	+0.030 +0.088	464	67,79
FJUMT-02-20-□	20	+0.030 +0.091	580	110,06
FJUMT-02-25-□	25	+0.030 +0.091	975	230,06
FJUMT-02-30-□	30	+0.030 +0.110	1,470	350,74
FJUMT-02-40-□	40	+0.030 +0.115	2,360	739,30
FJUMT-02-50-□	50	+0.030 +0.150	3,450	1249,30

For a floating version add the suffix -LL to the end of the part number
 Example: FJUMT - 02 -10 -LL for a floating version

J200 - for Aluminum shafting
A180 - FDA compliant
X - High temperature and chemical resistance
E7 - for steel and stainless steel shafting

Available with drylin® liners



E7



X

- X liner optional for chemicals/high temps up to +482°F (+250°C) for steel housing, up to +356°F (+180°C) for aluminum

Optional



J200



A180

Notes

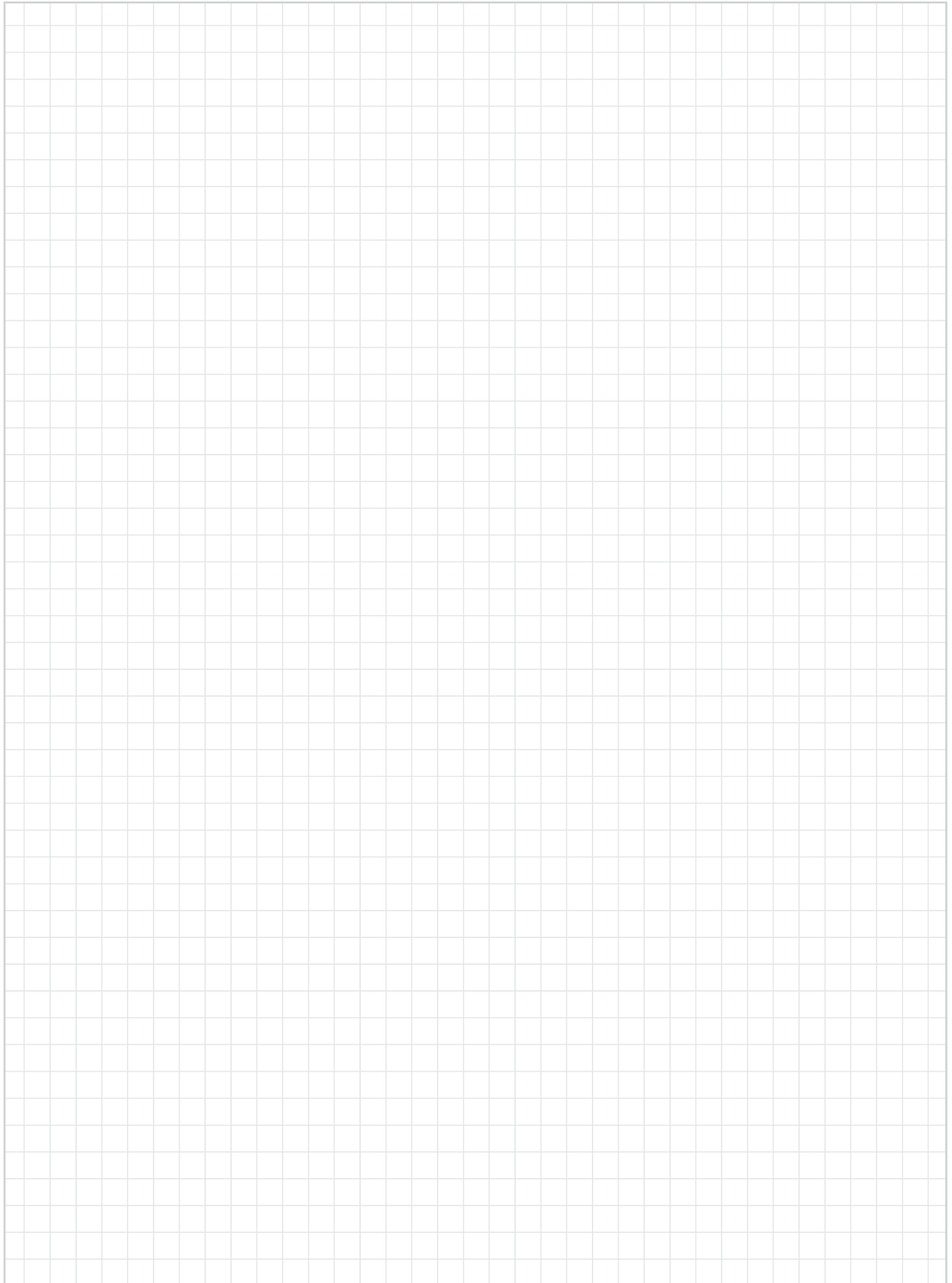

drylin® R quad blocks | Product Range

Closed design



● Housing: Aluminum, equipped with four drylin® R linear plain bearings

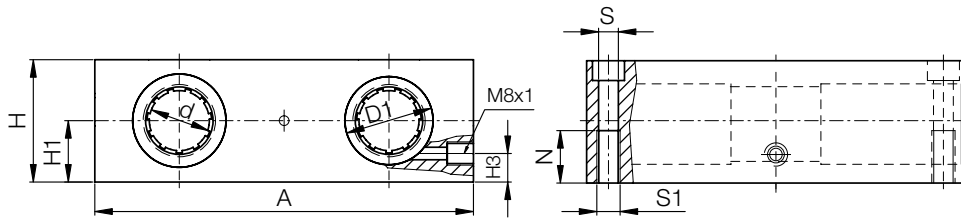
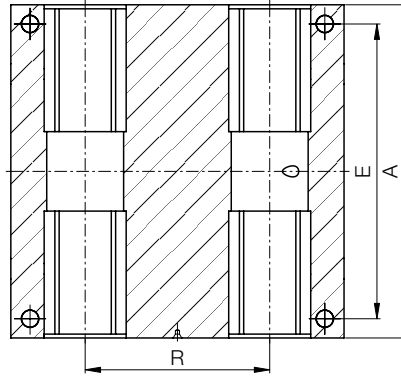

Order key

Type Options Size

RQA-01-10

Quad block with RJUM bearings	Aluminum housing	Standard with RJUM-01	Diameter
-------------------------------	------------------	-----------------------	----------

Options:

- 01: Standard with RJUM-01
- 03: with RJUM-03
- 04: with RJM-01



Please note: Installation instructions ► Page 1212

Dimensions [mm]

Part No.			d	D1	A	H	H1	H3	R	N	E	S	S1
Standard with RJUM-01	Self-aligning with RJUM-03	Solid plastic with RJM-01											
RQA-01-08	-	RQA-04-08	8	16	65	23	11.5	8	32	11	55	4.3	M5
RQA-01-10	RQA-03-10	RQA-04-10	10	19	70	25	12.5	10	34	13	60	4.3	M5
RQA-01-12	RQA-03-12	RQA-04-12	12	22	85	32	16	13	42	13	73	5.3	M6
RQA-01-16	RQA-03-16	RQA-04-16	16	26	100	36	18	15	54	13	88	5.3	M6
RQA-01-20	RQA-03-20	RQA-04-20	20	32	130	46	23	19	72	18	115	6.6	M8
RQA-01-25	RQA-03-25	RQA-04-25	25	40	160	56	28	24	88	22	140	8.4	M10
RQA-01-30	RQA-03-30	RQA-04-30	30	47	180	64	32	27	96	26	158	10.5	M12
RQA-01-40	RQA-03-40	RQA-04-40	40	62	230	80	40	35	122	34	202	13.5	M16

J200 - for Aluminum shafting

A180 - FDA compliant

X - High temperature and chemical resistance

E7 - for steel and stainless steel shafting

Are equipped with:



RJUM-01



RJUM-03



RJM-01

Available with drylin® liners



E7



X

● X liner optional for chemicals/high temps up to +482°F (+250°C) for steel housing, up to +356°F (+180°C) for aluminum

Optional



J200



A180

drylin® R quad blocks | Product Range

Open design



● Housing: Aluminum, equipped with four drylin® R linear plain bearings

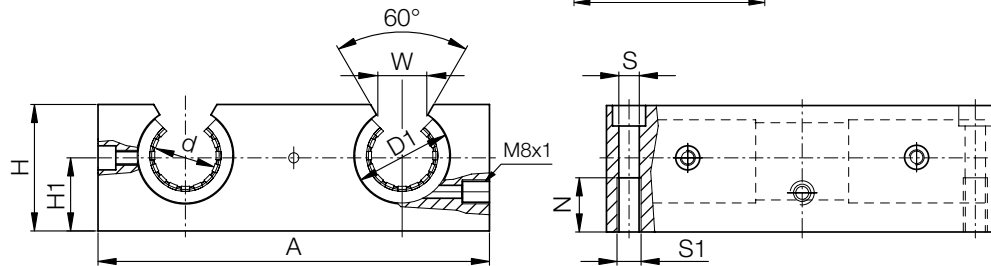
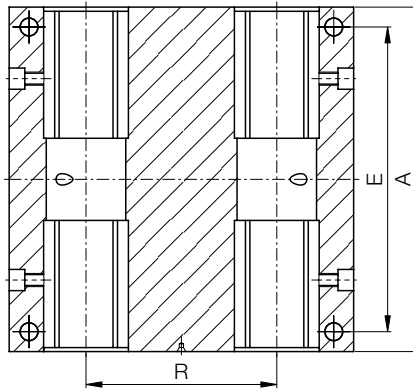

Order key

Type Options Size

OQA-01-12

Quad block with OJUM bearings	Aluminum housing	Standard with OJUM-01	Diameter
-------------------------------	------------------	-----------------------	----------

Options:

- 01: Standard with OJUM-01
- 03: with OJUM-03



Please note: Installation instructions ► Page 1212

Dimensions [mm]

Part No.	d	D1	A	H	H1	W	R	N	E	S	S1	
Standard with OJUM-01	Self-aligning with OJUM-03											
OQA-01-12	OQA-03-12	12	22	85	30	18	14	42	13	73	5.3	M6
OQA-01-16	OQA-03-16	16	26	100	35	22	17	54	13	88	5.3	M6
OQA-01-20	OQA-03-20	20	32	130	42	25	17	72	18	115	6.8	M8
OQA-01-25	OQA-03-25	25	40	160	51	30	21	88	22	140	9.0	M10
OQA-01-30	OQA-03-30	30	47	180	60	35	21	96	26	158	10.5	M12
OQA-01-40	OQA-03-40	40	62	230	77	45	27	122	34	202	13.5	M16

J200 - for Aluminum shafting

A180 - FDA compliant

X - High temperature and chemical resistance

E7 - for steel and stainless steel shafting

Are equipped with:



OJUM-01



OJUM-03

Available with drylin® liners



E7



X

- X liner optional for chemicals/high temps up to +482°F (+250°C) for steel housing, up to +356°F (+180°C) for aluminum

Optional



J200



A180

drylin® R quad blocks | Product Range

Closed, twin design

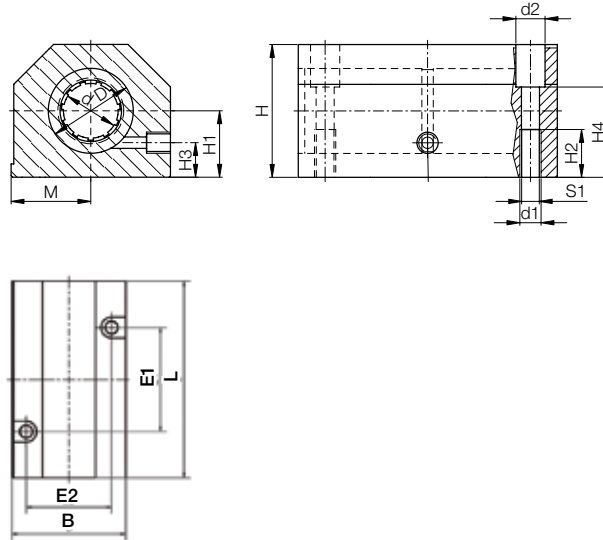

- Housing: Aluminum, equipped with 2 drylin® R linear plain bearings to increase the guide length



Order key

Type Options Size

RTA - 01 - 08

Tandem housing with RJUM bearing	Aluminum housing	Standard with RJUM-01	Diameter
----------------------------------	------------------	-----------------------	----------

Options:

- 01: Standard with RJUM-01
- 03: with RJUM-03
- 04: with RJM-01



Please note: Installation instructions ► Page 1212

Dimensions [mm]

Part No.	d	D	H	H1	H2	H3	H4	S1	B	L	M	E1	E2	d1	d2
Standard with RJUM-01		H6		+0.01 -0.02						+0.3	±0.02	±0.15	±0.15		
Self-aligning with RJUM-03															
Solid plastic with RJM-01															
RTA-01-08	8	16	28	13	13	8	23	M5	35	62	17.5	35	25	4.20	8
RTA-01-12	12	22	35	18	13	10	25	M6	43	76	21.5	40	30	5.20	10
RTA-01-16	16	26	42	22	13	12	30	M6	53	84	26.5	45	36	5.20	10
RTA-01-20	20	32	50	25	18	13	34	M8	60	104	30.0	55	45	6.80	11
RTA-01-25	25	40	60	30	22	15	40	M10	78	130	39.0	70	54	8.60	15
RTA-01-30	30	47	70	35	26	16	48	M12	87	152	43.5	85	62	10.30	18
RTA-01-40	40	62	90	45	34	20	60	M16	108	176	54.0	100	80	14.25	20

J200 - for Aluminum shafting

A180 - FDA compliant

X - High temperature and chemical resistance

E7 - for steel and stainless steel shafting

Are equipped with:



RJUM-01



RJUM-03



RJM-01

Available with drylin® liners



E7



X

- X liner optional for chemicals/high temps up to +482°F (+250°C) for steel housing, up to +356°F (+180°C) for aluminum

Optional



J200



A180

drylin® R quad blocks | Product Range

Open, twin design



- Housing: Aluminum, equipped with 2 drylin® R linear plain bearings to increase the guide length

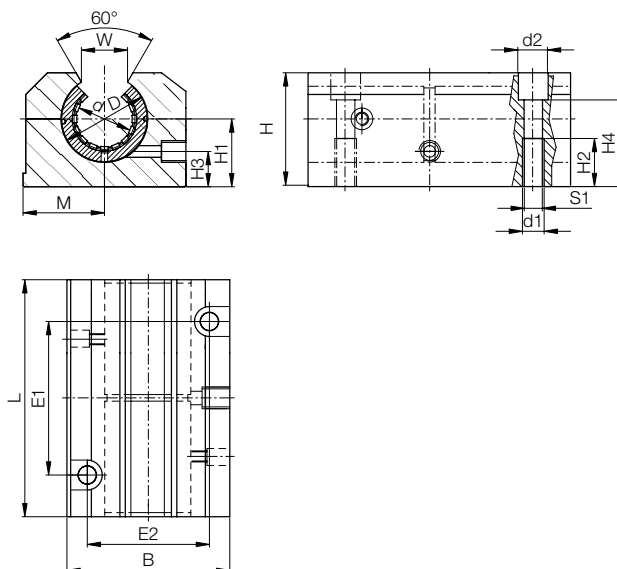

Order key

Type	Options	Size
------	---------	------

OTA - 01 - 12

Tandem housing with OJUM bearing	Aluminum housing	Standard with OJUM-01	Diameter
----------------------------------	------------------	-----------------------	----------

Options:

- 01: Standard with OJUM-01
- 03: with OJUM-03



Please note: Installation instructions ► Page 1212

Dimensions [mm]

Part No.		d	D	H	H1	H2	H3	H4	S1	B	L	M	E1	E2	d1	d2	W
Standard with OJUM-01	Self-aligning with OJUM-03		H6		+0.01 -0.02						+0.3	±0.02	±0.15	±0.15			
OTA-01-12	OTA-03-12	12	22	30	18	13	10	25	M6	43	76	21.5	40	30	5.20	10	14
OTA-01-16	OTA-03-16	16	26	35	22	13	12	30	M6	53	84	26.5	45	36	5.20	10	17
OTA-01-20	OTA-03-20	20	32	42	25	18	13	34	M8	60	104	30.0	55	45	6.80	11	17
OTA-01-25	OTA-03-25	25	40	51	30	22	15	40	M10	78	130	39.0	70	54	8.60	15	21
OTA-01-30	OTA-03-30	30	47	60	35	26	16	48	M12	87	152	43.5	85	62	10.30	18	21
OTA-01-40	OTA-03-40	40	62	77	45	34	20	60	M16	108	176	54.0	100	80	14.25	20	27

J200 - for Aluminum shafting

A180 - FDA compliant

X - High temperature and chemical resistance

E7 - for steel and stainless steel shafting

Are equipped with:



OJUM-01 OJUM-03

Available with drylin® liners



E7 X

- X liner optional for chemicals/high temps up to +482°F (+250°C) for steel housing, up to +356°F (+180°C) for aluminum

Optional



J200 A180

drylin® R quad blocks | Product Range

Closed, long design

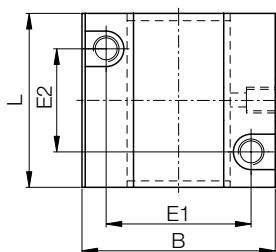
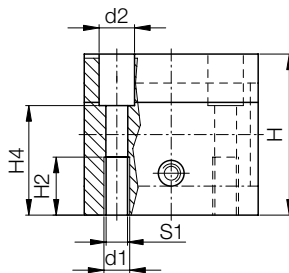
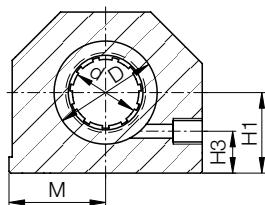

- Housing: Aluminum, equipped with 2 drylin® R linear plain bearings



Order key

Type	Options	Size
Linear housing with RJUM bearings	Aluminum housing	Standard with RJUM-01
		Diameter

RGA - 01 - 12

Options:

- 01: Standard with RJUM-01
- 03: with RJUM-03
- 04: with RJM-01



Please note: Installation instructions ► Page 1212

Dimensions [mm]

Part No.			d	D	H	H1	H2	H3	H4	S1	B	L	M	E1	E2	d1	d2
Standard with RJUM-01	Self-aligning with RJUM-03	Solid plastic with RJM-01		H6		+0.01 -0.02						±0.3	±0.02	±0.15	±0.15		
RGA-01-08	-	RGA-04-08	8	16	28	13	10	8	14	M4	35	32	17.5	25	20	3.2	6
RGA-01-12	RGA-03-12	RGA-04-12	12	22	35	18	11	10	25	M5	43	39	21.5	32	23	4.2	6
RGA-01-16	RGA-03-16	RGA-04-16	16	26	42	22	13	12	30	M6	53	43	26.5	40	26	5.2	10
RGA-01-20	RGA-03-20	RGA-04-20	20	32	50	25	18	13	34	M8	60	54	30.0	45	32	6.8	11
RGA-01-25	RGA-03-25	RGA-04-25	25	40	60	30	22	15	40	M10	78	67	39.0	60	40	8.6	15
RGA-01-30	RGA-03-30	RGA-04-30	30	47	70	35	22	16	48	M10	87	79	43.5	68	45	8.6	15
RGA-01-40	RGA-03-40	RGA-04-40	40	62	90	45	26	20	60	M12	108	91	54.0	86	58	10.3	18

J200 - for Aluminum shafting

A180 - FDA compliant

X - High temperature and chemical resistance

E7 - for steel and stainless steel shafting

Are equipped with:



RJUM-01



RJUM-03



RJM-01

Available with drylin® liners



E7



X

- X liner optional for chemicals/high temps up to +482°F (+250°C) for steel housing, up to +356°F (+180°C) for aluminum

Optional



J200



A180

drylin® R quad blocks | Product Range

Open, long design



- Housing: Aluminum, equipped with 2 drylin® R linear plain bearings

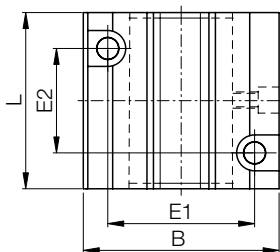
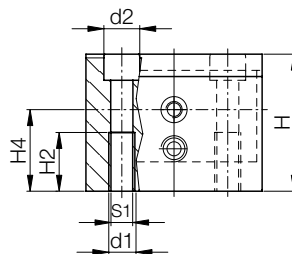
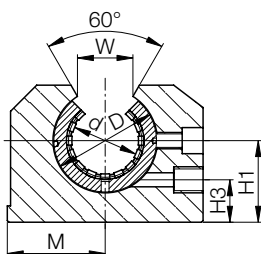

Order key

Type	Options	Size
OGA - 01 - 12		
Linear housing with OJUM bearings	Aluminum housing	Standard with OJUM-01
		Diameter

Options:

- 01: Standard with OJUM-01
- 03: with OJUM-03



Please note: Installation instructions ► Page 1212

Dimensions [mm]

Part No. Standard with OJUM-01	Self-aligning with OJUM-03	d	D H6	H	H1 +0.01 -0.02	H2	H3	H4	S1	B	L ±0.3	M ±0.02	E1 ±0.15	E2 ±0.15	d1	d2	W +0.6
OGA-01-12	OGA-03-12	12	22	28	18	11	8	25	M5	43	39	21.5	32	23	4.2	8	14
OGA-01-16	OGA-03-16	16	26	35	22	13	12	30	M6	53	43	26.5	40	26	5.2	10	17
OGA-01-20	OGA-03-20	20	32	42	25	18	13	34	M8	60	54	30.0	45	32	6.8	11	17
OGA-01-25	OGA-03-25	25	40	51	30	22	15	40	M10	78	67	39.0	60	40	8.6	15	21
OGA-01-30	OGA-03-30	30	47	60	35	22	16	48	M10	87	79	43.5	68	45	8.6	15	21
OGA-01-40	OGA-03-40	40	62	77	45	26	20	60	M12	108	91	54.0	86	58	10.3	18	27

J200 - for Aluminum shafting

A180 - FDA compliant

X - High temperature and chemical resistance

E7 - for steel and stainless steel shafting

Are equipped with:



OJUM-01



OJUM-03

Available with drylin® liners



E7



X

- X liner optional for chemicals/high temps up to +482°F (+250°C) for steel housing, up to +356°F (+180°C) for aluminum

Optional



J200



A180

drylin® R pillow blocks | Product Range

Closed, short design

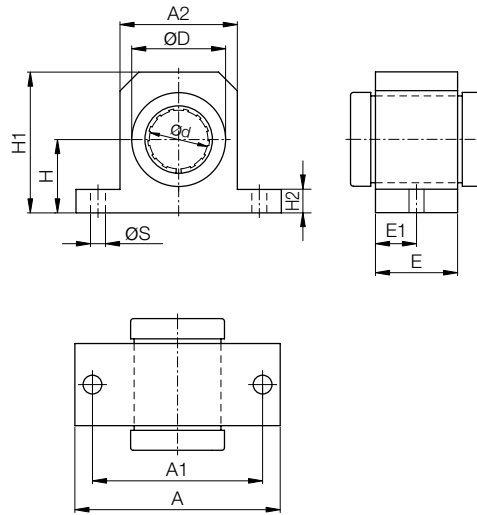

Order key

Type	Options	Size
RGAS - 01 - 12		
Linear Housing with RJUM bearings	Aluminum housing	Small
Standard with RJUM-01	Diameter	

- Housing: Aluminum, equipped with drylin® R linear plain bearings
- Variations:
Standard: RGAS-01-Ø
Self-aligning: RGAS-03-Ø
Solid polymer bearing: RGAS-04-Ø (cost-effective, light)

Options:

- 01: Standard with RJUM-01
- 03: with RJUM-03
- 04: with RJM-01



Please note: Installation instructions ► Page 1212

Dimensions [mm]

Part No.	d	D	H	H1	H2	A	A1	A2	E	E1	S		
Standard with RJUM-01	Self-aligning with RJUM-03	Solid plastic with RJM-01											
RGAS-01-12	RGAS-03-12	RGAS-04-12	12	22	18	35.0	6	52	42	30	20	10	5.3
RGAS-01-16	RGAS-03-16	RGAS-04-16	16	26	22	40.5	7	56	46	34	22	11	5.3
RGAS-01-20	RGAS-03-20	RGAS-04-20	20	32	25	48.0	8	70	58	40	28	14	6.4
RGAS-01-25	RGAS-03-25	RGAS-04-25	25	40	30	58.0	10	80	68	50	40	20	6.4
RGAS-01-30	RGAS-03-30	RGAS-04-30	30	47	35	67.0	10	88	76	58	48	24	6.4
RGAS-01-40	RGAS-03-40	RGAS-04-40	40	62	45	85.0	12	108	94	74	56	28	8.4

J200 - for Aluminum shafting

A180 - FDA compliant

X - High temperature and chemical resistance

E7 - for steel and stainless steel shafting

Are equipped with:



RJUM-01



RJUM-03



RJM-01

Available with drylin® liners



E7



X

- X liner optional for chemicals/high temps up to +482°F (+250°C) for steel housing, up to +356°F (+180°C) for aluminum

Optional



J200



A180

drylin® R pillow blocks | Product Range

Open, short design

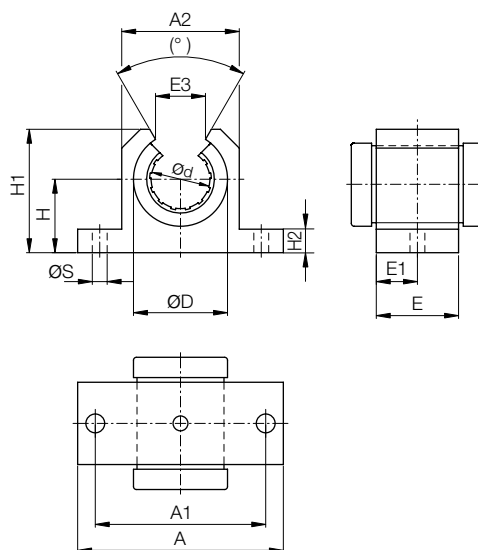

- Housing: Aluminum, equipped with drylin® R linear plain bearings
- Variations:
Standard: OGAS-01-Ø
Self-aligning: OGAS-03-Ø



Order key

Type Options Size

OGAS - 01 - 12

Linear Housing with OJUM bearings	Aluminum housing	Small	Standard with OJUM-01	Diameter
-----------------------------------	------------------	-------	-----------------------	----------

Options:

- 01: Standard with OJUM-01
- 03: with OJUM-03



Please note: Installation instructions ► Page 1212

Dimensions [mm]

Part No.	d	D	H	H1	H2	A	A1	A2	E	E1	E3	(°)	S	
Standard with OJUM-01	Self-aligning with OJUM-03													
OGAS-01-12	OGAS-03-12	12	22	18	28	6	52	42	30	20	10	14	78	5.3
OGAS-01-16	OGAS-03-16	16	26	22	33.5	7	56	46	34	22	11	17	78	5.3
OGAS-01-20	OGAS-03-20	20	32	25	42	8	70	58	40	28	14	17	60	6.4
OGAS-01-25	OGAS-03-25	25	40	30	51	10	80	68	50	40	20	21	60	6.4
OGAS-01-30	OGAS-03-30	30	47	35	60	10	88	76	58	48	24	21	54	6.4
OGAS-01-40	OGAS-03-40	40	62	45	77	12	108	94	74	56	28	27	54	8.4

J200 - for Aluminum shafting

A180 - FDA compliant

X - High temperature and chemical resistance

E7 - for steel and stainless steel shafting

Are equipped with:



OJUM-01 OJUM-03

Available with drylin® liners



E7 X

- X liner optional for chemicals/high temps up to +482°F (+250°C) for steel housing, up to +356°F (+180°C) for aluminum

Optional



J200 A180

Notes

A large grid area for taking notes, consisting of a 30x30 grid of small squares. The grid is empty and occupies the majority of the page.



drylin® linear technology – drylin® inch and metric shafts

Hard-anodized aluminum shafts

Stainless steel for high corrosion resistance

Hardened steel and stainless steel shafts

Round shafts with or without support



drylin® inch shafts | Advantages

Suitable liner materials:



	The All-rounder – iglide® J	The specialist – iglide® J200	The extreme – iglide® X	The endurance runner – iglide® E7
Application temperature	from -58°F to +194°F (-50°C to +90°C)	from -58°F to +194°F (-50°C to +90°C)	from -148°F to +482°F (-100°C to +250°C)	from -58°F to +158°F (-50°C to +70°C)
Best coefficient of friction with	Steel shaft	Hard-anodized aluminum	Hard-chromed steel	Steel/stainless steel shaft
Volume resistance	> 10 ⁹ Ωcm	> 10 ⁹ Ωcm	< 10 ⁹ Ωcm	> 10 ⁹ Ωcm
Moisture absorption	1.3% weight	0.7% weight	0.5% weight	< 0.1% weight
Maximum service life with	Hard-anodized aluminum	Hard-anodized aluminum	Hardened stainless steel	Steel/stainless steel shaft
Potential counter partner	All shaft materials	Hard-anodized aluminum	Hardened stainless steel	Steel/stainless steel shaft
Permissible stat. surface pressure	5,076 psi (35MPa)	3,336 psi (23MPa)	21,760 psi (150MPa)	2,611 psi (18MPa)
Part No.	JUI ...	J200UI...	XUI ...	E7UI ...

Available shaft materials:

Aluminum

- Ideal in combination with liners made from iglide® J/J200
- Lightweight
- Low wear
- Corrosion-free
- Available from stock

Steel

- E7 liners for up to 8 times longer service life
- Cost-effective standard
- High load capacity
- Dry area applications
- Hard chrome-plated also available
- Lower coefficient of friction against plastic bearings

Stainless steel

- A180 liners for food and pharmaceutical applications
- Corrosion resistance
- High chemical resistance
- Ideal solution for wet applications
- 316 stainless steel for extremely chemical intensive applications



Please remember that this is a technical surface. Small color variations are possible due to variable coating depths.

Wear

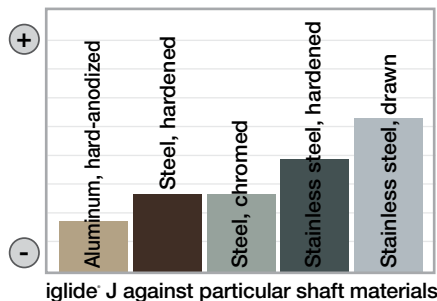

Coefficient of friction

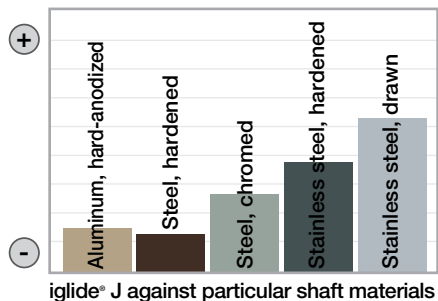

Corrosion

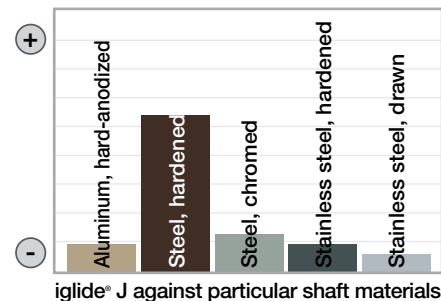

Weight

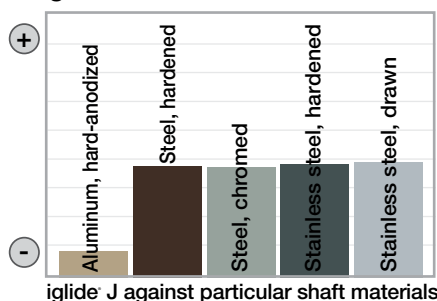

Cost

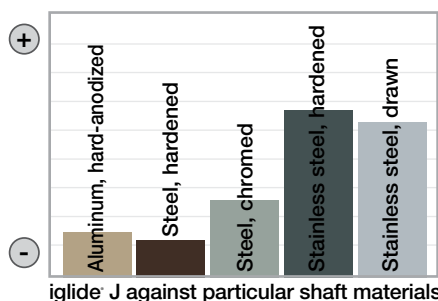

Chemical charge

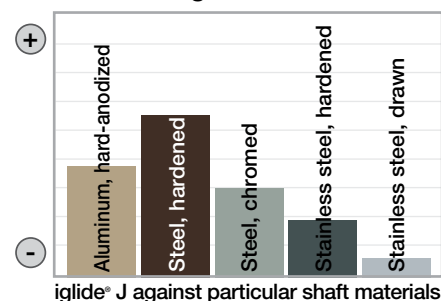

drylin® inch shafts | Product overview

	Aluminum		Steel			Hard stainless		Soft stainless		
	●	⌘	●	●	⌘	●	⌘	●	●	
Designation	AWI	AWUI	SWI2	SWI	SWUI	EWI	EWUI	EEWI	EWIR	EWIS
Material	EN AW 6061/6060/6063		Case hardened	Case hardened		Case hardened	Case hardened	Case hardened	Not hardened	
			1055	1060		440C	420C		304	316
			(1.1209)	(1.0601)		(1.4125)	(1.4034)		(1.4301)	(1.4571)
Ø 0.25	●		▲	▲	▲	▲	▲	▲	◆	◆
Ø 0.375	●		▲	▲	▲	▲	▲	▲	◆	◆
Ø 0.50	●	●	▲	▲	▲	▲	▲	▲	◆	◆
Ø 0.625	●	●	▲	▲	▲	▲	▲	▲	◆	◆
Ø 0.75	●	●	▲	▲	▲	▲	▲	▲	◆	◆
Ø 1.00	●	●	▲	▲	▲	▲	▲	▲	◆	◆
Ø 1.25	●		▲	▲	▲	▲	▲	▲	◆	◆
Ø 1.50	●	●	▲	▲	▲	▲	▲	▲	◆	◆
Ø 2.00	●		▲	▲	▲	▲	▲	▲	◆	◆
Ø Tolerance	Class L		Class L	Class L		Class L	Class L		Class L	
Max. supply length Ø 0.25 - 0.375	6 feet		9.8 feet	12 feet		12 feet	9.8 feet		12 feet	
Max. supply length Ø 0.50 - 2.00	12 feet		12 feet	12 feet		12 feet	12 feet		12 feet	
Surface	hard-anodized MIL-A-8625, Type III Class I		hardened/ground	hardened/ground		hardened/ground	hardened/ground		drawn, polished	
Surface roughness Ra	≤ 20		≤ 12	≤ 12		≤ 12	≤ 12		≤ 12	
Hardness	450-550 HV		59+ HRC	60+ HRC		50+ HRC	50+8 HRC		not hardened	
Roundness	0.004"		≤ 1/2 Ø tol	≤ 1/2 Ø tol		≤ 1/2 Ø tol	≤ 1/2 Ø tol		≤ 1/2 Ø tol	
Straightness	0.004"/ft		0.001"-0.002"/ft	0.001"-0.002"/ft		0.001"-0.002"/ft	0.001"-0.002"/ft		0.001"-0.002"/ft	

Delivery time: ● From stock ▲ 1-2 weeks ◆ available as custom

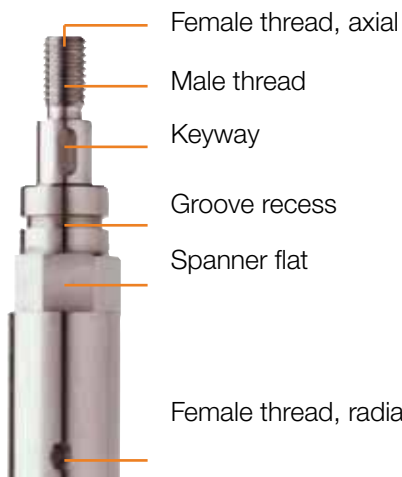

"Nominal Diameter (In)"	Class L	
	Min	Max
1/4	0.2490	0.2495
3/8	0.3740	0.3745
1/2	0.4990	0.4995
5/8	0.6240	0.6245
3/4	0.7490	0.7495
1	0.9990	0.9995
1-1/4	1.2490	1.2495
1-1/2	1.4989	1.4994
2	1.9987	1.9994

Special machining

All shafts can be individually machined. Please send us your drawing. We can then provide a quotation quickly.

Inquiries can be requested online as well:

► www.igus.com/shaftinquiry

Request form ► Page 1348

drylin® inch shafts | Product Range

Aluminum shaft, inch



igus® recommendation: Linear plain bearings equipped with iglide® J200 liners for the longest service life



Order key

Type	Size
AW	I -06- <input type="text"/>
Aluminum shaft	Inch
	Outer Ø
	Shaft length [inch]

Properties:

Material: 6061-T6
Straightness: 0.004"/ft
Hardness: 75 HB
Surface: hard-anodized
 mil-A-8625 Type III Class I
 < .002"

Layer Thickness: > .0016"
Surface Hardness: 450-550 HV
 approx. (60 RC)
Roughness: RMS = 4-20
Spec. Electr. Resistance: 4*10¹¹ Ohm mm²/m
Chemical Resistance: 2<ph<9



Hard anodized surfaces

► Page 1209

Dimensions [mm]

Part No.	Design	Outer Ø	Tolerance	Max. length*	Weight
				inch	[lb/ft]
AWI-04	Solid Shaft	0.25	0/-0.001"	72"	0.057
AWI-06	Solid Shaft	0.375	0/-0.001"	144"	0.130
AWI-08	Solid Shaft	0.50	0/-0.001"	144"	0.231
AWI-10	Solid Shaft	0.625	0/-0.001"	144"	0.361
AWI-12	Solid Shaft	0.75	0/-0.001"	144"	0.519
AWI-16	Solid Shaft	1.00	0/-0.001"	144"	0.924
AWI-20	Solid Shaft	1.25	0/-0.001"	144"	1.44
AWI-24	Solid Shaft	1.50	0/-0.001"	144"	2.08
AWI-32	Solid Shaft	2.00	0/-0.001"	144"	3.70

*longer lengths available



*Shaft supports available upon request

drylin® inch shafts | Product Range

Supported aluminum shaft, inch

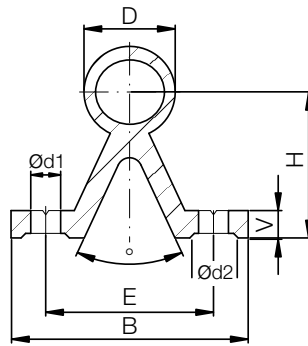

Order key

Type	Size
AW U I -08-	<input type="text"/>
Aluminum shaft	
Supported	
Inch	
Outer Ø	
Shaft length [inch]	

Properties:

Material: 6063-T6

Surface: hard-anodized aluminum
mil-A-8625 Type III Class I
< .002"

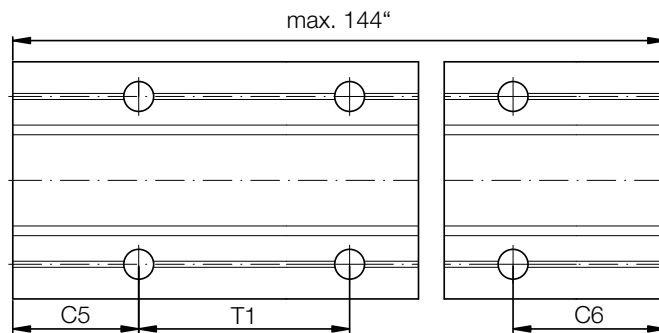

Dimensions (inch)

Part No.	D Ø -.006"	B	H	V	d1	d2	(°)	E	T1	C5/C6		Max. length* inch	Weight (lbs/ft)
										min.	max.		
AWUI-08	0.500	1.50	1.125	0.19	0.169	0.217	30°	1.000	4.00	1	2.95	120"	0.6
AWUI-10	0.625	1.63	1.125	0.252	0.193	0.256	30°	1.125	4.00	1	2.95	120"	0.9
AWUI-12	0.75	1.75	1.500	0.252	0.220	0.276	30°	1.250	6.00	1	3.95	120"	1.2
AWUI-16	1.00	2.13	1.750	0.252	0.280	0.335	30°	1.500	6.00	1	3.95	120"	1.5
AWUI-20	1.25	2.50	2.125	0.311	0.343	0.394	30°	1.875	6.00	1	3.95	120"	2.5
AWUI-24	1.50	3.00	2.500	0.374	0.343	0.394	30°	2.250	8.00	1	4.95	120"	2.6

*longer lengths available



SWI



SWUI



igus® recommendation:
Linear plain bearings
equipped with iglide® E7
liners for 8 times longer
service life



Order key

Type	Size
SW	I -06- □
Steel shaft	Inch
Outer Ø	Shaft length [inch]

● For supported shafts:

- ▶ Shaft support supplied in lengths of 600mm max.
- ▶ Hole pitches symmetrical C5 = C6

Dimensions [inch] – 1055 steel shafting 1.1209

Part No.	d Ø	Weight [lb/ft]	Max. length feet	Effective hardness depth (with 1.1209)
SWI2-04	0.25	0.168	9.8 ft	0.016"
SWI2-06	0.375	0.372	9.8 ft	0.016"
SWI2-08	0.50	0.660	12 ft	0.024"
SWI2-10	0.625	1.032	12 ft	0.024"
SWI2-12	0.75	1.500	12 ft	0.035"
SWI2-16	1.00	2.664	12 ft	0.035"
SWI2-20	1.25	4.176	12 ft	0.059"
SWI2-24	1.50	6.000	12 ft	0.059"
SWI2-32	2.00	10.680	12 ft	0.059"

Dimensions [inch] – 1060 steel shafting 1.0601

Part No.	d Ø	Weight [lb/ft]	Max. length	Effective hardness depth (with 1.0601)
SWI-04	0.25	0.168	12 ft	0.027"
SWI-06	0.375	0.372	12 ft	0.027"
SWI-08	0.50	0.660	12 ft	0.040"
SWI-10	0.625	1.032	12 ft	0.040"
SWI-12	0.75	1.500	12 ft	0.06"
SWI-16	1.00	2.664	12 ft	0.080"
SWI-20	1.25	4.176	12 ft	0.08"
SWI-24	1.50	6.000	12 ft	0.08"
SWI-32	2.00	10.680	12 ft	0.1"

SWUI

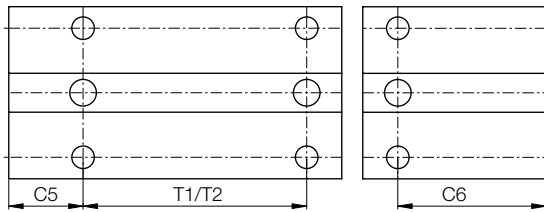
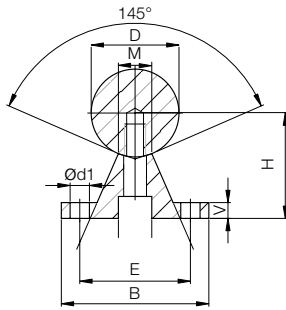

Dimensions [inch] – supported 1060 steel shafting 1.0601

Part No.	D Ø	B	H ±0.002	V	d1	M	E ±0.010	T1	C5/C6		Max length* feet	Weight [lb/ft]	
									min.	max.			
SWUI-08	0.50	1.500	1.125	0.187	0.169	0.250	1.000	4	1	2.95	144	0.7	1.75
SWUI-10	0.625	1.625	1.125	0.250	0.193	0.312	1.125	4	1	2.95	144	1.1	2.64
SWUI-12	0.75	1.750	1.500	0.250	0.221	0.375	1.250	6	1	3.95	144	1.6	3.97
SWUI-16	1.00	2.125	1.750	0.250	0.281	0.500	1.500	6	1	3.95	144	2.8	5.65
SWUI-20	1.25	2.500	2.125	0.312	0.330	0.562	1.875	6	1	3.95	144	4.3	7.93
SWUI-24	1.50	3.000	2.500	0.375	0.406	0.687	2.250	8	1	4.95	144	6.2	12.88
SWUI-32	2.00	3.750	3.250	0.500	0.531	0.875	2.750	8	1	4.95	144	11.0	19.60



- For supported shafts:
 - ▶ Shaft support supplied in lengths of 600mm max.
 - ▶ Hole pitches symmetrical C5 = C6

Dimensions [mm] – hardened stainless steel 440C (1.4125)

Part No.	d Ø	Weight [lb/ft]	Max. length	Effective hardness depth with 440C (1.4125)
EWI-04	0.25	0.168	12ft	0.027"
EWI-06	0.375	0.372	12ft	0.027"
EWI-08	0.50	0.660	12ft	0.04"
EWI-10	0.625	1.032	12ft	0.04"
EWI-12	0.75	1.500	12ft	0.06"
EWI-16	1.00	2.664	12ft	0.08"
EWI-20	1.25	4.176	12ft	0.08"
EWI-24	1.50	6.000	12ft	0.08"
EWI-32	2.00	10.680	12ft	0.1"

 **Order key**

Type	Size
EW	I -06- <input type="text"/>
Stainless steel shaft 440C	Inch
	Outer Ø
	Shaft length [inch]

 **Order key**

Type	Size
EEW	I -06- <input type="text"/>
Stainless steel shaft 420C	Inch
	Outer Ø
	Shaft length [inch]

Available shaft materials

Stainless steel 440C (1.4125), hardened/ground ► EWI
 Stainless steel 420C (1.4034), hardened/ground ► EEWI

Available upon request

Stainless steel 304 (1.4301), drawn ► EWIR
 Stainless steel 316 (1.4571), drawn ► EWIS

Dimensions [mm] – hardened stainless steel 420C (1.4034)

Part No.	d Ø	Weight [lb/ft]	Max. length	Effective hardness depth with 420C (1.4034)
EEWI-04	0.25	0.168	9.8ft	0.016"
EEWI-06	0.375	0.372	9.8ft	0.016"
EEWI-08	0.50	0.660	12ft	0.024"
EEWI-10	0.625	1.032	12ft	0.024"
EEWI-12	0.75	1.500	12ft	0.035"
EEWI-16	1.00	2.664	12ft	0.035"
EEWI-20	1.25	4.176	12ft	0.059"
EEWI-24	1.50	6.000	12ft	0.059"
EEWI-32	2.00	10.680	12ft	0.059"

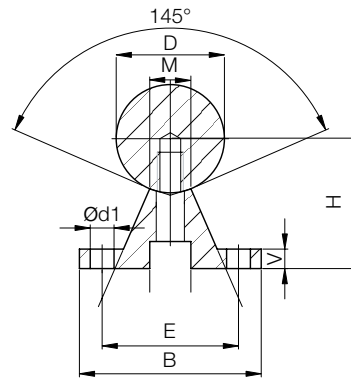

EWUI: Supported stainless steel shaft



igus® recommendation: Linear plain bearings equipped with iglide® E7 liners for 8 times longer service life

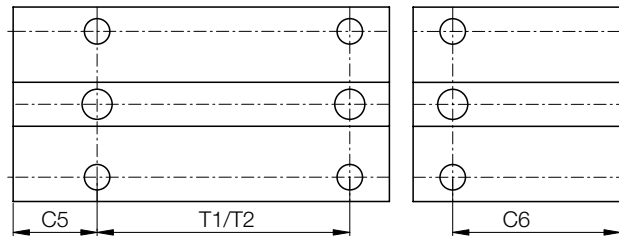

Dimensions [inch] – supported stainless steel shafts 440C (1.4125)





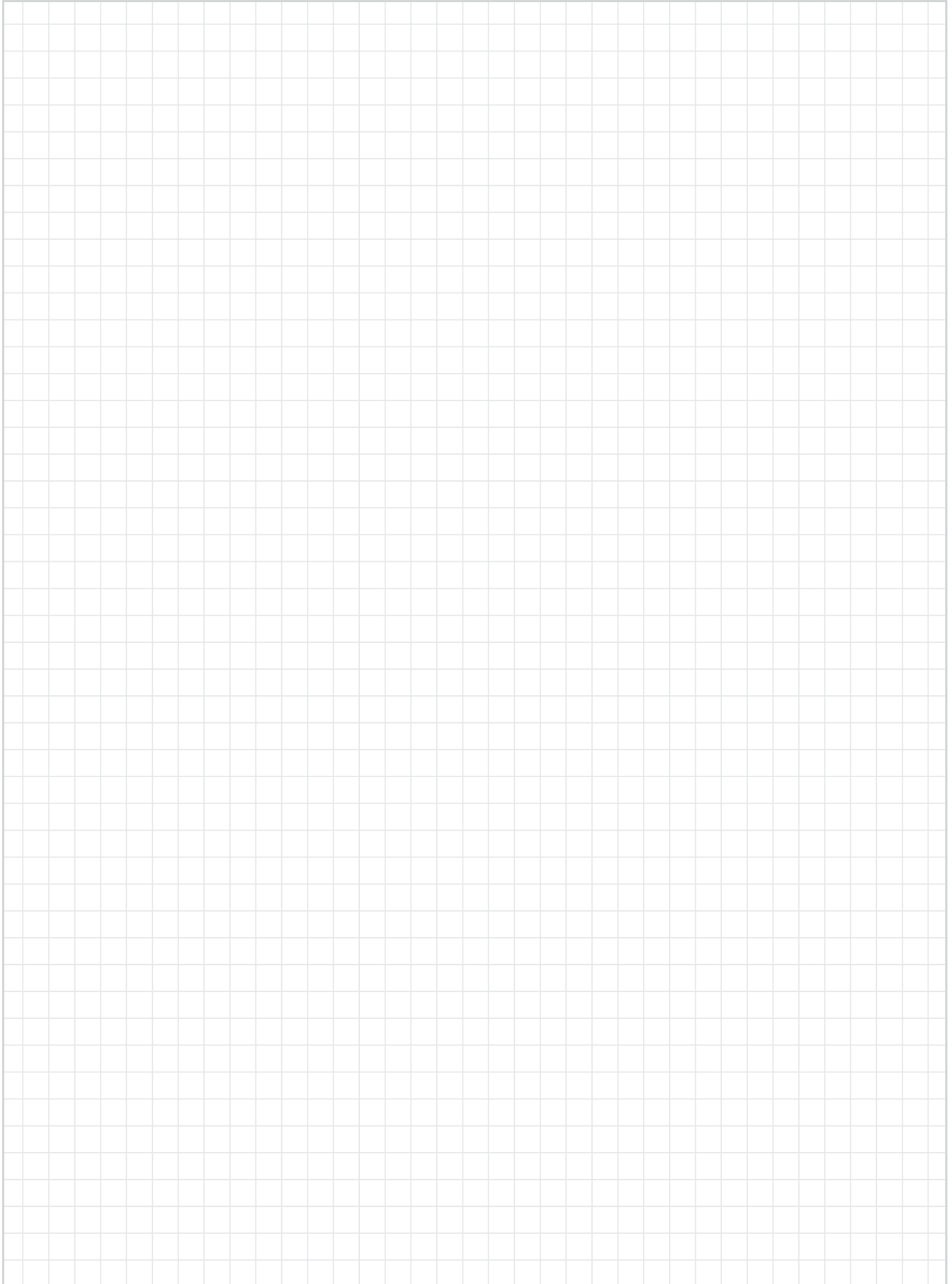

Part No.	D Ø	B	H +/-	V	d1	M	E +/-	T1	C5/C6		Max length* inches	Weight [lb/ft]
									Min.	Max.		
EWUI-08	0.50	1.500	1.125	0.187	0.169	0.250	1.000	4	1	2.95	144	0.7
EWUI-10	0.625	1.625	1.125	0.250	0.193	0.312	1.125	4	1	2.95	144	1.1
EWUI-12	0.75	1.750	1.500	0.250	0.221	0.375	1.250	6	1	3.95	144	1.6
EWUI-16	1.00	2.125	1.750	0.250	0.281	0.500	1.500	6	1	3.95	144	2.8
EWUI-20	1.25	2.500	2.125	0.312	0.330	0.562	1.875	6	1	3.95	144	4.3
EWUI-24	1.50	3.000	2.500	0.375	0.406	0.687	2.250	8	1	4.95	144	6.2
EWUI-32	2.00	3.750	3.250	0.500	0.531	0.875	2.750	8	1	4.95	144	11.0

Notes



drylin® metric shafts | Advantages

Suitable liner materials for metric shafts:

	 The All-rounder – iglide® J	 The specialist – iglide® J200	 The extreme – iglide® X	 The endurance runner – iglide® E7	 The FDA-compliant – iglide® A180	 Blue Sky Thinking FDA/EU-compliant – iglide® A160
Application temperature	from -58°F to +194°F (-50°C to +90°C)	from -58°F to +194°F (-50°C to +90°C)	from -148°F to +482°F (-100°C to +250°C)	from -58°F to +158°F (-50°C to +70°C)	from -58°F to +194°F (-50°C to +90°C)	from -58°F to +194°F (-50°C to +90°C)
Best coefficient of friction with	Steel shaft	Hard-anodized aluminum	Hard-chromed steel	Steel/stainless steel shaft	Stainless steel shaft	Hardened stainless steel shafts
Volume resistance	> 10 ¹⁰ Ωcm	> 10 ¹⁰ Ωcm	< 10 ¹⁰ Ωcm	> 10 ¹⁰ Ωcm	> 10 ¹⁰ Ωcm	> 10 ¹⁰ Ωcm
Moisture absorption	1.3% weight	0.7% weight	0.5% weight	< 0.1% weight	0.2% weight	< 0.1% weight
Maximum service life with	Hard-anodized aluminum	Hard-anodized aluminum	Hardened stainless steel	Steel/stainless steel shaft	Stainless steel shaft	Hardened stainless steel shafts
Potential counter partner	All shaft materials	Hard-anodized aluminum	Hardened stainless steel	Steel/stainless steel shaft	All shaft materials	Stainless steel
Permissible stat. surface pressure	5,076 psi (35MPa)	3,336 psi (23MPa)	21,760 psi (150MPa)	2,611 psi (18MPa)	4,061 psi (28MPa)	2,176 psi (15MPa)
Part No.	JUM-...	J200UM-...	XUM-...	E7UM-...	A180UM-...	A160UM-...

Available shaft materials:

Aluminum

- Ideal in combination with liners made from iglide® J/J200
- Lightweight
- Low wear
- Corrosion-free
- Available from stock

Steel

- E7 liners for up to 8 times longer service life
- Cost-effective standard
- High load capacity
- Dry area applications
- Hard chrome-plated also available
- Lower coefficient of friction against plastic bearings

Stainless steel

- A160 liners for food and pharmaceutical applications
- Corrosion resistance
- High chemical resistance
- Ideal solution for wet applications
- 316 stainless steel for extremely chemical intensive applications



Please remember that this is a technical surface. Small color variations are possible due to variable coating depths.



Inch shafting available ► Page 1316

Wear

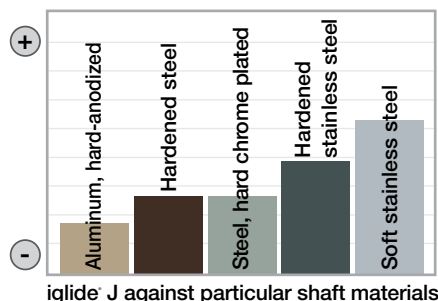

Coefficient of friction

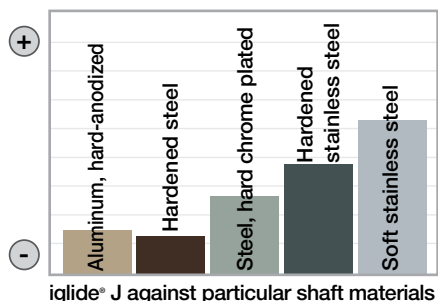

Corrosion

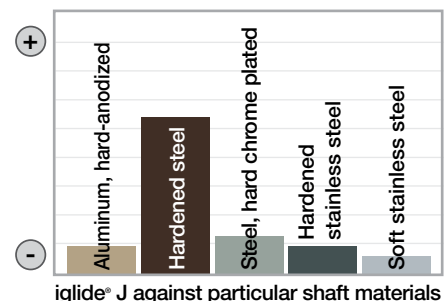

Weight

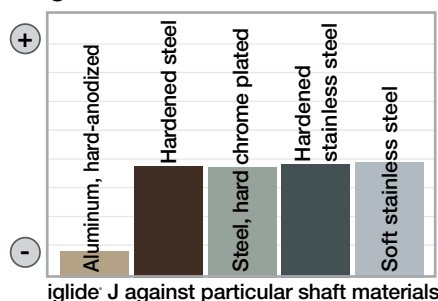

Cost

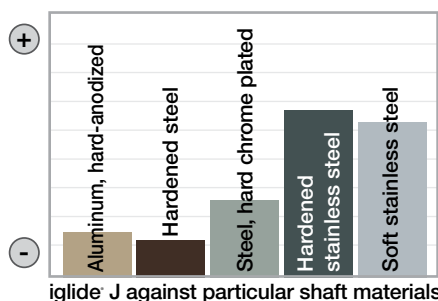

Chemical charge

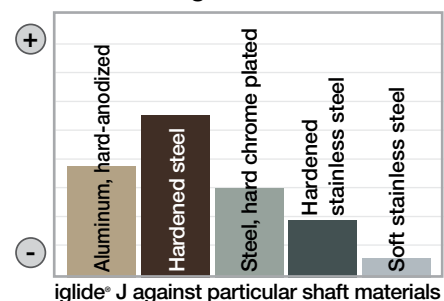

drylin® metric shafts | Product range

	Aluminum			Steel				Hardened stainless steel				Soft stainless		Carbon fiber
				●		●		●		●		●		
				●		●		●		●		●		○
Marking				SWUM		SWUMH		EWUM		EEWUM		EWUMS		CWM
	AWM	AWUM	AWMR	SWM	SWUMN	SWMH	SWUMHN	EWM	EWUMN	EEWM	EEWUMN	EWMR	EWMS	
Material	EN AW 6061/6060/6063			1.1213 (AISI 1055)		1.1213 Hard-Chromed		1.4112 (AISI 440B)		1.4034 (AISI 420)		1.4301 (AISI 304) 1.4571 (AISI 316T)		CFK Composite
Ø 6	●			▲		▲		▲ ²		▲				
Ø 8	●			▲		▲		▲ ²		▲				
Ø 10	●	●		▲		▲		▲ ²		▲		▲	▲	
Ø 12	●	●	●	▲	▲	▲	▲	▲	▲	▲	▲	▲	▲	▲
Ø 16	●	●	●	▲	▲	▲	▲	▲	▲	▲	▲	▲	▲	▲
Ø 20	●	●	●	▲	▲	▲	▲	▲	▲	▲	▲	▲	▲	▲
Ø 25	●	●	●	▲	▲	▲	▲	▲	▲	▲	▲	▲	▲	
Ø 30	●	●		▲	▲	▲	▲	▲	▲	▲	▲	▲	▲	▲
Ø 40	●	●		▲	▲	▲	▲	▲	▲	▲				
Ø 50	●			▲	▲	▲	▲	▲	▲	▲	▲			
Ø 60	●													
Ø Tolerance	h8	-0.1	h9	h6	h6	h7	h7	h6	h6	h6	h6	h9	h9	-0.1 mm
Max. supply length Ø 8–10	3,000			3,000		3,000		3,000		3,000				2,000
Max. supply length Ø 12–50	3,000	4,000	3,000	6,000	6,000	6,000	6,000	6,000	6,000	6,000	6,000	3,000	3,000	2,000
Surface	Hard anodized			Hardened/ground		Hard chromed		Hardened/ground		Hardened/ground		Drawn, polished		UCU unidirectional/cross winding/unidirectional
Surface roughness Ra	< 0.6			0.15–0.3		0.15–0.3		0.15–0.3		0.15–0.3		0.3–0.6		< 0.6 µm
Hardness	up to 550 HV			60+4 HRC		60+4 HRC		52+8 HRC		52+8 HRC		soft		
Roundness	≤ 1/2 Ø Tolerance			≤ 1/2 Ø Tolerance		≤ 1/2 Ø Tolerance		≤ 1/2 Ø Tolerance		≤ 1/2 Ø Tolerance		≤ 1/2 Ø Tolerance		± 0.05 mm

Delivery time: ● From stock ▲ simply cut shafts 3–8 days; machined shafts 12 days

¹ Hollow profile 30 · 7.5; 40 · 10; 50 · 11

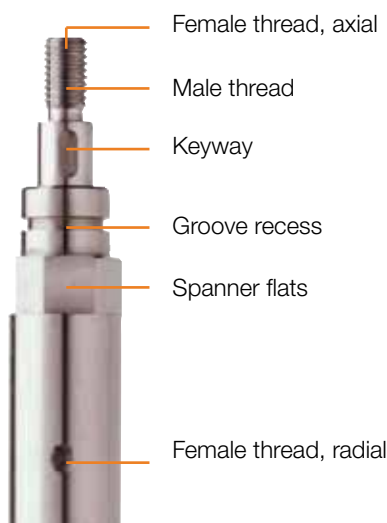

Special machining

All shafts can be individually machined. Please send us your drawing. We can then provide a quotation quickly.



Inquiries can be put online as well:

► www.igus.com/shaftinquiry

drylin® metric shafts | Product Range

Precision aluminum shafts



AWMR

AWMP

- Material: EN AW 6061/6060
- Straightness: EN 754-3
- Hardness: 75 HB
- Surface: hard-anodized
- Hardness: up to 550 HV
- Due to the technical surface finish slight color variations may occur between shafts
- Overall length tolerance +/-1mm unless otherwise specified



Order key

Type	Size	Options
A W M P - 06 - 2000		
Aluminum shaft	Metric	Precise
Outer Ø	Shaft length [mm]	

AWMP: Solid shaft up to Ø 25 mm
hollow shaft from Ø 30 mm

AWMR: Tube



igus® recommendation: Linear plain bearings equipped with iglide® J200 liners for the longest service life



Hard anodized surfaces
► Page 1092

Dimensions [mm]

Part No.	Design	Outer Ø	Tolerance	Insulation thickness	Inner Ø	Max. length	Weight [kg/m]
AWMP-06	Solid shaft	6	h8	–	–	3,000	0.08
AWMP-08	Solid shaft	8	h8	–	–	3,000	0.14
AWMP-10	Solid shaft	10	h8	–	–	3,000	0.22
AWMP-12	Solid shaft	12	h8	–	–	3,000	0.32
AWMP-16	Solid shaft	16	h8	–	–	3,000	0.56
AWMP-20	Solid shaft	20	h8	–	–	3,000	0.88
AWMP-25	Solid shaft	25	h8	–	–	3,000	1.37
AWMP-30	Hollow shaft	30	h8	7.5	15	3,000	1.48
AWMP-40	Hollow shaft	40	h8	10	20	3,000	2.63
AWMP-50	Hollow shaft	50	h8	11	28	3,000	3.75
AWMP-60	Hollow shaft	60	h8	11	38	3,000	4.7

Part No.	Design	Outer Ø	Tolerance	Insulation thickness	Inner Ø	Max. length	Weight [kg/m]
AWMR-12	Tube	12	h8	2	8	3,000	0.17
AWMR-16	Tube	16	h8	2	12	3,000	0.25
AWMR-20	Tube	20	h9	2	16	3,000	0.32
AWMR-25	Tube	25	h9	3	19	3,000	0.59



Order example:
AWMP-12-500 corresponds to a precision aluminum shaft Ø 12 mm, 500 mm in length



Inch shafting available
► Page 1316

drylin® metric shafts | Product Range

drylin®
metric
shafts

Supported aluminum shaft



- Material: EN AW 6061/6060 /6063
- Straightness: DIN 12020
- Hardness: 75 HB
- Surface: hard-anodized
- Hardness: up to 550 HV
- Symmetrical standard hole pattern C5 = C6
- Due to the technical surface finish slight color variations may occur between shafts
- Overall length tolerance +/-1mm unless



Hard anodized surfaces
► Page 1092



Order key

Type	Size	Options
AWUM* - 12 - 2000		
Aluminum shaft	Supported	Metric
	Outer Ø	
Shaft length [mm]		

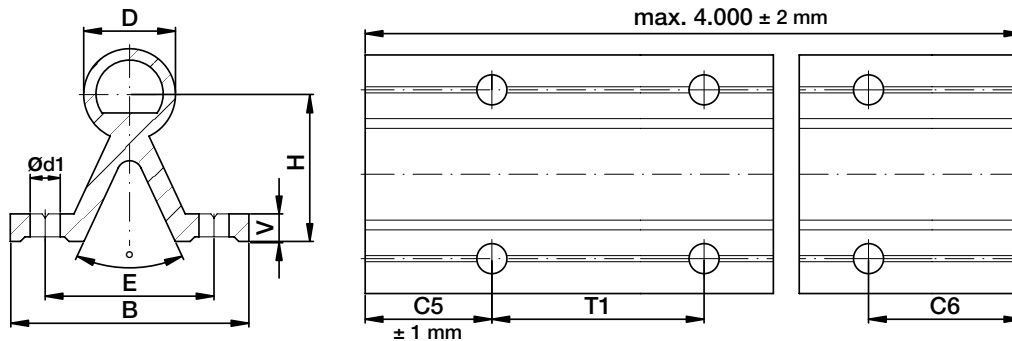

Dimensions [mm]

Part No.	D	B	H	V	d1	(°)	E	T1	C5/C6		Max. length	Weight [kg/m]
	-0.1		±0.25				±0.25		min.	max.		
AWUM-12	12	40	22	5	4.5	50	29	75	20	57	4,000	0.75
AWUM-16	16	45	26	5	5.5	50	33	100	20	69	4,000	1.00
AWUM-20	20	52	32	6	6.6	50	37	100	20	69	4,000	1.42
AWUM-25	25	57	36	6	6.6	50	42	120	20	79	4,000	1.81
AWUM-30	30	69	42	7	9.0	50	51	150	20	94	4,000	2.69
AWUM-40 ⁹⁹⁾	40	73	50	8	9.0	50	55	200	20	119	4,000	4.06

⁹⁹⁾ Tolerance for shaft diameter D is -0.15

*AWUM is the European part number equivalent for AWUM



Order example:

AWUM*-16-500 corresponds to a supported aluminum shaft Ø 16 mm, 500 mm in length



Inch shafting available

► Page 1316

Standard steel shafts



SWM SWUMN SWUM



igus® recommendation:
Linear plain bearings
equipped with iglide® E7
liners for 8 times longer
service life



Inch shafting available
▶ Page 1316



Order key

Type	Size	Options	
S W M - 06 - 2000			
Steel shaft	Metric	Outer Ø	Shaft length [mm]

- Completely supported and mounted with standard aluminum support
- Available shaft materials:
 - ▶ Cf53 steel (AISI 1055), hardened/ground
 - ▶ Cf53 steel (AISI 1055), hard-chromed

- For supported shafts:
 - ▶ Partial shaft support supplied in lengths of 600mm max.
 - ▶ Standard pitch T2, T1 also possible upon request
 - ▶ Symmetrical hole pitches C5 = C6

Dimensions [mm] – steel shafting 1.1213

Part No.	d	Weight [kg/m]	Max. length	Effective hardness depth (with 1.1213)
SWM-06	06	0.222	3,000	0.8
SWM-08	08	0.359	4,000	0.9
SWM-10	10	0.617	4,000	0.9
SWM-12	12	0.888	6,000	1.0
SWM-16	16	1.578	6,000	1.2
SWM-20	20	2.466	6,000	1.6
SWM-25	25	3.853	6,000	1.8
SWM-30	30	5.549	6,000	2.0
SWM-40	40	9.865	6,000	2.2
SWM-50	50	15.413	6,000	2.4

Dimensions [mm] – hard-chromed steel shafting 1.1213

Part No.	d	Weight [kg/m]	Max. length	Effective hardness depth (with 1.1213)
SWMH-06	06	0.222	3,000	0.8
SWMH-08	08	0.359	4,000	0.9
SWMH-10	10	0.617	4,000	0.9
SWMH-12	12	0.888	6,000	1.0
SWMH-16	16	1.578	6,000	1.2
SWMH-20	20	2.466	6,000	1.6
SWMH-25	25	3.853	6,000	1.8
SWMH-30	30	5.549	6,000	2.0
SWMH-40	40	9.865	6,000	2.2
SWMH-50	50	15.413	6,000	2.4



Order example:

SWM-16-500: steel shaft 16mm Ø 1.1213, 500mm in length

Supported steel shaft

SWUM

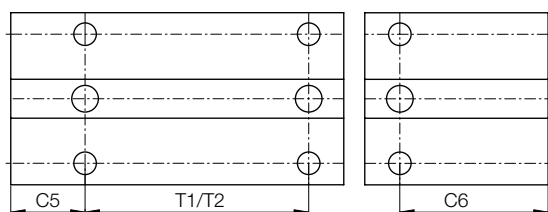
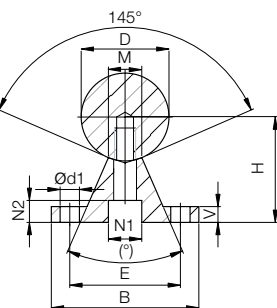

SWUMN

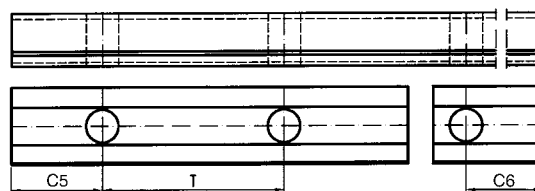
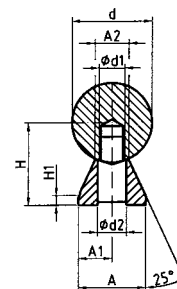

Dimensions [mm] – supported steel shafting 1.1213

Part No.	D	B	H	V	N1	N2	d1	M	°	E	T1 ^{*)}	C5/C6		T2	C5/C6		Weight [kg/m]
												min.	max.		min.	max.	
			±0.02								±0.15	for T1	Standard	for T2	Standard		
SWUM-12	12	40	22	5	8.0	5.0	4.5	5.8	50	29	75	20	57	120	20	79	1.75
SWUM-16	16	45	26	5	9.5	6.0	5.5	7.0	50	33	100	20	69	150	20	94	2.64
SWUM-20	20	52	32	6	11.0	6.5	6.6	8.3	50	37	100	20	69	150	20	94	3.97
SWUM-25	25	57	36	6	14.0	8.5	6.6	10.8	50	42	120	20	79	200	20	119	5.65
SWUM-30	30	69	42	7	17.0	10.5	9.0	11.0	50	51	150	20	94	200	20	119	7.93
SWUM-40	40	73	50	8	17.0	10.5	9.0	15.0	50	55	200	20	119	300	20	169	12.88
SWUM-50	50	84	60	9	19.0	12.5	11.0	19.0	46	63	200	20	119	300	20	169	19.60

^{*)} Pitch T1 on request; standard is T2

Dimensions [mm] – supported steel shafting 1.1213

Part No.	d	H	H1	A	A1	A2	d1	d2	T	C5/C6		Weight [kg/m]
										min.	max.	
			±0.02			±0.02						
SWUMN-12	12	14.5	3	11	5.5	5.4	M4	4.5	75	20	57	1.62
SWUMN-16	16	18	3	14	7.0	7.0	M5	5.5	75	20	57	2.54
SWUMN-20	20	22	3	17	8.5	8.1	M6	6.6	75	20	57	3.81
SWUMN-25	25	26	3	21	10.5	10.3	M8	9.0	75	20	57	5.62
SWUMN-30	30	30	3	23	11.5	11.0	M10	11.0	100	20	69.5	7.63
SWUMN-40	40	39	4	30	15.0	15.0	M12	13.5	100	20	69.5	13.47
SWUMN-50	50	46	5	35	17.5	19.0	M14	15.5	100	20	69.5	20.31

Low level supported shafts are delivered unassembled.



Order example:

SWUM-16-500: supported steel shaft 16mm ø made from 1.1213, 500mm length

Stainless steel shafts



EWM



EEWM



EWMR



Inch shafting available
▶ Page 1316

- Completely supported and mounted with standard aluminum support
- For supported shafts:
 - ▶ Shaft support supplied in lengths of 600mm max.
 - ▶ Standard pitch T2, T1 also possible upon request
 - ▶ Symmetrical hole pitches C5 = C6

Dimensions [mm] – hardened stainless steel AISI 440B

Part No.	d	Weight [kg/m]	Max. length	Effective hardness depth with 440C (1.4125)
EWM-06 sm	06	0.222	3,000	0.8
EWM-08 sm	08	0.359	4,000	0.9
EWM-10 sm	10	0.617	4,000	0.9
EWM-12	12	0.888	6,000	1.0
EWM-16	16	1.578	6,000	1.2
EWM-20	20	2.466	6,000	1.6
EWM-25	25	3.853	6,000	1.8
EWM-30	30	5.549	6,000	2.0
EWM-40	40	9.865	6,000	2.2
EWM-50	50	15.413	6,000	2.4

drylin® metric shafts | Product Range

Materials: AISI 440B, AISI 420C, AISI 304, AISI 316Ti



Order key

Type Size Options

E W M - 06 - 2000

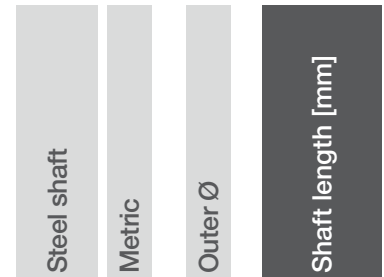

Available shaft materials

- AISI 440B, hardened/ground ▶ EWM
- AISI 420C, hardened/ground ▶ EEWM
- AISI 304, drawn ▶ EWMR
- AISI 316Ti, drawn ▶ EWMS

Dimensions [mm] – hardened stainless steel AISI 420C

Part No.	d	Weight [kg/m]	Max. length	Effective hardness depth with 420C (1.4034)
EEWM-06	06	0.222	3,000	0.8
EEWM-08	08	0.359	4,000	0.9
EEWM-10	10	0.617	4,000	0.9
EEWM-12	12	0.888	6,000	1.0
EEWM-16	16	1.578	6,000	1.2
EEWM-20	20	2.466	6,000	1.6
EEWM-25	25	3.853	6,000	1.8
EEWM-30	30	5.549	6,000	2.0
EEWM-40	40	9.865	6,000	2.2
EEWM-50	50	15.413	6,000	2.4

Dimensions [mm] – stainless steel AISI 304 (EWMR) or AISI 316Ti soft stainless steel (EWMS)

Part No.	d	Weight [kg/m]	Max. length
EWMR-10	10	0.617	4,000
EWMS-10	10	0.617	4,000
EWMR-12	12	0.888	6,000
EWMR-16	16	1.578	6,000
EWMR-20	20	2.466	3,000
EWMS-20	20	2.466	6,000
EWMR-25	25	3.853	6,000
EWMR-30	30	5.549	6,000



Order example:

EWM-16-500: Stainless steel shaft (AISI 440B) with 16mm Ø, 500mm in length

Supported stainless steel shafts

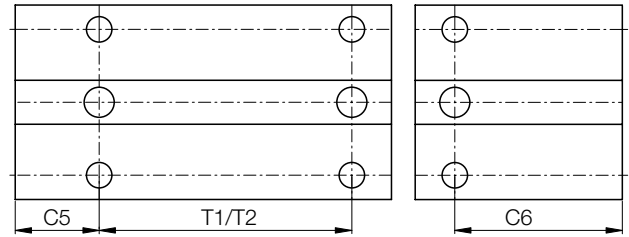
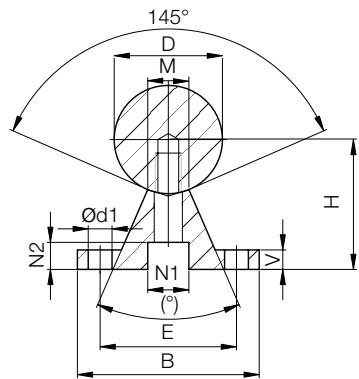

EWUM: Supported stainless steel shaft

Shaft support blocks for Ø 20mm made of stainless steel VA

- Connecting sizes as standard supports made from aluminum



igus® recommendation: Linear plain bearings equipped with iglide® E7 liners for 8 times longer service life

Available materials and lengths:

AISI 440B, max. 6,000mm

Hole pattern:

T2: T2 pitch (standard)

T1: T1 pitch (upon request)

Dimensions [mm] – supported stainless steel shafts AISI 440B

Part No.	D	B	H	V	N1	N2	d1	M	(°)	E	T1 ⁸⁷⁾	C5/C6		T2	C5/C6		Weight
												Min.	Max.		Min.	Max.	
				±0.02							±0.15	for T1	Standard	for T2	Standard	[kg/m]	
EWUM-12	12	40	22	5	8.0	5.0	4.5	5.8	50	29	75	20	57	120	20	79	1.75
EWUM-16	16	45	26	5	9.5	6.0	5.5	7.0	50	33	100	20	69	150	20	94	2.64
EWUM-20	20	52	32	6	11.0	6.5	6.6	8.3	50	37	100	20	69	150	20	94	3.97
EWUM-25	25	57	36	6	14.0	8.5	6.6	10.8	50	42	120	20	79	200	20	119	5.65
EWUM-30	30	69	42	7	17.0	10.5	9.0	11.0	50	51	150	20	94	200	20	119	7.93
EWUM-40	40	73	50	8	17.0	10.5	9.0	15.0	50	55	200	20	119	300	20	169	12.88
EWUM-50	50	84	60	9	19.0	12.5	11.0	19.0	46	63	200	20	119	300	20	169	19.60

⁸⁷⁾ T1 pitch upon request; standard is T2



Order example:

EWUM-16-500-T1: Supported stainless steel shaft (AISI 440B) with 16mm outer Ø, 500mm length, T1 pitch

Low level supported stainless steel shafts

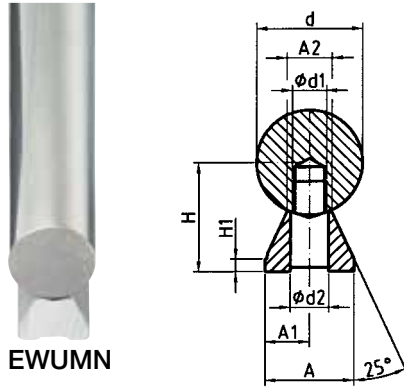

EWUMN

EWUMN: Low level supported stainless steel shaft

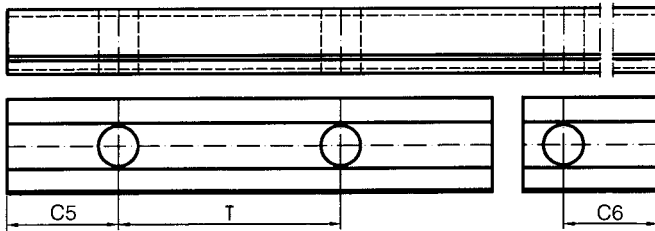

Order key

Type	Size	Options
E W U M N - 20 - 2000 - T1		
Low level supported stainless steel shaft, metric	Outer Ø	Shaft length [mm]
		Hole pattern

Dimensions [mm] – low level supported stainless steel shafts AISI 440B

Part No.	Outer Ø	H ±0.02	H1	A	A1	A2	d1	d2	T	C5/C6		Weight [kg/m]
	d					±0.02				Min.	Max.	
EWUMN-12	12	14.5	3	11	5.5	5.4	M4	4.5	75	20	57	1.62
EWUMN-16	16	18	3	14	7.0	7.0	M5	5.5	75	20	57	2.54
EWUMN-20	20	22	3	17	8.5	8.1	M6	6.6	75	20	57	3.81
EWUMN-25	25	26	3	21	10.5	10.3	M8	9.0	75	20	57	5.62
EWUMN-30	30	30	3	23	11.5	11.0	M10	11.0	100	20	69.5	7.63
EWUMN-40	40	39	4	30	15.0	15.0	M12	13.5	100	20	69.5	13.47
EWUMN-50	50	46	5	35	17.5	19.0	M14	15.5	100	20	69.5	20.31

Low level supported shafts are delivered unmounted.



Order example:

EWUMN-16-500: Low level supported stainless steel shaft (AISI 440B) with 16mm outer Ø, 500mm length

drylin® metric shafts | Product Range

Partially supported stainless steel shafts



EWUM-ES/
EWUMS-ES

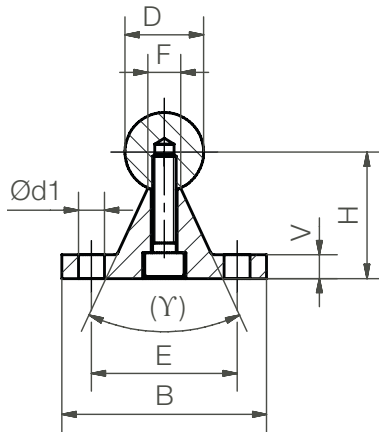

Standard shaft support blocks made of stainless steel
 ● Connection sizes are identical to aluminum supports
 ▶ Page 1334

! igus® recommendation: linear plain bearings equipped with iglide® E7 liners for 8 times longer service life

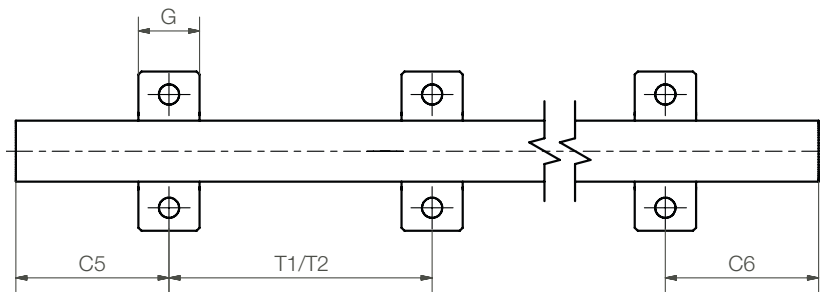

Dimensions [mm] – partially supported stainless steel shafts AISI 440B

Part No.	D	B	H	V	d1	E	Y	F	G	T1	C5/C6		T2	C5/C6	
											for T1		Standard	for T2	
											Min.	Max.		Min.	Max.
EWUM-ES-12	12	40	22	5	4.5	29	–	5.8	14	75	20	57	120	20	79
EWUM-ES-16	16	45	26	5	5.5	33	–	7.0	16	100	20	69	150	20	94
EWUM-ES-20	20	52	32	6	6.6	37	50°	8.3	20	100	20	69	150	20	94
EWUM-ES-25	25	57	36	6	6.6	42	–	10.8	25	150	20	79	200	20	119
EWUM-ES-30	30	69	42	7	9.0	51	–	11.0	25	150	20	94	200	20	119
EWUM-ES-40	40	73	50	8	9.0	55	–	15.0	25	200	20	119	300	20	169

T2 pitch as standard, T1 upon request



Order example:

EWUM-ES-20-500, partially supported stainless steel shaft (shaft and support made of stainless steel), AISI 440B material, T2 pitch, outer Ø 20mm, L = 500mm



Order key

Type	Size	Options
E W U M S - ES - 20 - 500 - T2		
Partially supported stainless steel shaft, metric	Material	Outer Ø
		Shaft length [mm]
		Hole pattern

Available materials and lengths:

AISI 440B, max. 6,000mm

► EWUM

AISI 316Ti, max. 3,000mm

► EWUMS

Options:

Blank: AISI 440B material

S: AISI 316Ti

Hole pattern:

T2: T2 pitch (standard)

T1: T1 pitch

Dimensions [mm] – partially supported stainless steel shafts AISI 316Ti

Part No.	D	B	H	V	d1	E	γ	F	G	T1	C5/C6		T2	C5/C6	
											for T1		Standard	for T2	
											Min.	Max.		Min.	Max.
	h6		±0.02												
EWUMS-ES-12	12	40	22	5	4.5	29	–	5.8	14	75	20	57	120	20	79
EWUMS-ES-16	16	45	26	5	5.5	33	–	7.0	16	100	20	69	150	20	94
EWUMS-ES-20	20	52	32	6	6.6	37	50°	8.3	20	100	20	69	150	20	94
EWUMS-ES-25	25	57	36	6	6.6	42	–	10.8	25	150	20	79	200	20	119
EWUMS-ES-30	30	69	42	7	9.0	51	–	11.0	25	150	20	94	200	20	119
EWUMS-ES-40	40	73	50	8	9.0	55	–	15.0	25	200	20	119	300	20	169

T2 pitch as standard, T1 upon request



Order example:

EWUM-ES-20-500, partially supported stainless steel shaft (shaft and support made of stainless steel), AISI 316Ti material, T1 pitch, outer Ø 20mm, L = 500mm



EWUMN-ES/ EWUMSN-ES

Low level shaft support blocks made of stainless steel

- Connection sizes are identical to low-level aluminum supports ► [Page 1335](#)



igus® recommendation: Linear plain bearings equipped with iglide® E7 liners for 8 times longer service life

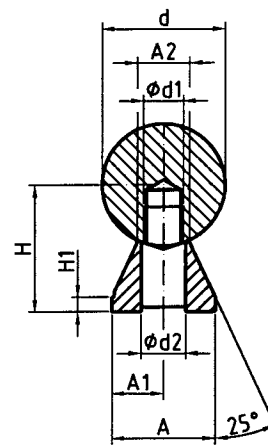
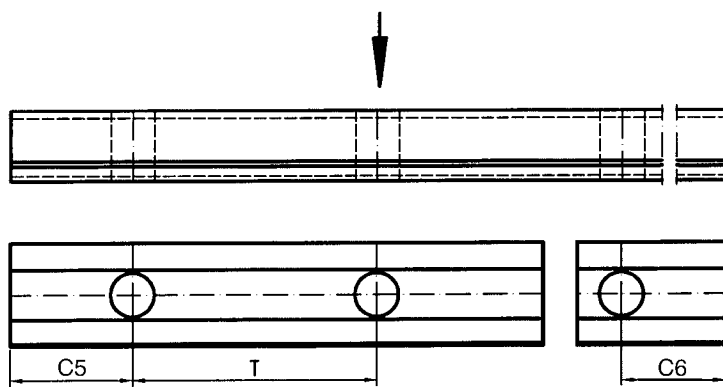

Dimensions [mm] – low level partially supported stainless steel shafts AISI 440B

Part No.	d	H ±0.02	H1	A	A1	A2	d1	d2	T	C5/C6		Weight [kg/m]
										Min.	Max.	
EWUMN-ES-12	12	14.5	3	11	5.5	5.4	M4	4.2	75	20	57.0	1.00
EWUMN-ES-16	16	18.0	3	14	7.0	7.0	M5	5.2	75	20	57.0	1.76
EWUMN-ES-20	20	22.0	3	17	8.5	8.1	M6	6.2	75	20	57.0	2.77
EWUMN-ES-25	25	26.0	3	21	10.5	10.3	M8	8.2	75	20	57.0	4.35
EWUMN-ES-30	30	30.0	3	23	11.5	11.0	M10	10.2	100	20	69.5	6.01
EWUMN-ES-40	40	39.0	4	30	15.0	15.0	M12	12.5	100	20	69.5	10.80

Low-level partially supported stainless steel shafts are supplied unassembled



Order example:

EWUMN-ES-20-500: Low level partially supported stainless steel shafts. AISI 440B material, T2 pitch (standard), 20mm outer Ø, 500mm length



Order key

Type	Size	Options
EWUMN S - ES - 20 - 500 - T2		
Partially supported stainless steel shaft, metric	Material	Outer Ø
		Shaft length [mm]
		Hole pattern

Available materials and lengths:

AISI 440B, max. 6,000mm

▶ EWUMN

AISI 316Ti, max. 3,000mm

▶ EWUMSN

Dimensions [mm] – low level partially supported stainless steel shafts AISI 316Ti

Part No.	d	H ±0.02	H1	A	A1	A2	d1	d2	T	C5/C6		Weight [kg/m]
										Min.	Max.	
EWUMSN-ES-12	12	14.5	3	11	5.5	5.4	M4	4.2	75	20	57.0	1.00
EWUMSN-ES-16	16	18.0	3	14	7.0	7.0	M5	5.2	75	20	57.0	1.76
EWUMSN-ES-20	20	22.0	3	17	8.5	8.1	M6	6.2	75	20	57.0	2.77
EWUMSN-ES-25	25	26.0	3	21	10.5	10.3	M8	8.2	75	20	57.0	4.35
EWUMSN-ES-30	30	30.0	3	23	11.5	11.0	M10	10.2	100	20	69.5	6.01
EWUMSN-ES-40	40	39.0	4	30	15.0	15.0	M12	12.5	100	20	69.5	10.80

Low-level partially supported stainless steel shafts are supplied unassembled



Order example:

EWUMSN-ES-20-500-T2: Low-level partially supported stainless steel shaft. AISI 316Ti material, T2 pitch, outer Ø 20mm, length 500mm

Carbon fiber shafts



CWM



Order key

Type	Size	Options
C W M - 12 - 1000		
Carbon fiber shaft	Metric	Outer Ø
		Shaft length [mm]

- Material: CFK composite
- Roundness tolerance: $\pm 0.05\text{mm}$
- Diameter tolerance: -0.1mm
- Application temperature: Max. $+176^{\circ}\text{F}$
- Color: Black

Dimensions [mm]

Part No.	Design	Outer Ø	Inner Ø	Max. length	Weight
		-0.1	-0.1		[g]
CWM-12	Hollow shaft	12	9.0	2,000	70
CWM-16	Hollow shaft	16	12.5	2,000	120
CWM-20	Hollow shaft	20	16.0	2,000	170
CWM-30	Hollow shaft	30	26.0	2,000	270



Order example:

CWM-16-500: Carbon fiber shaft, 16mm outer Ø, 500mm length



Order key

Type Size

TA - 08

Shaft end support,
floating

Inner Ø

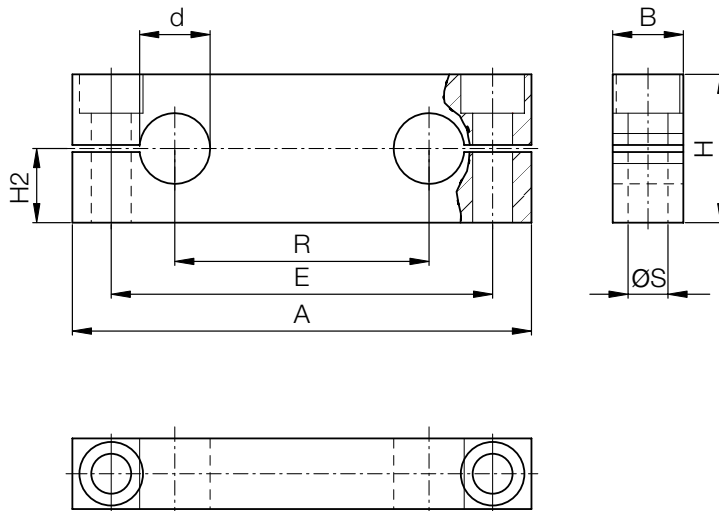

Material: aluminum
Threaded fixing hole

Dimensions [mm]

Part No.	d	A	B	H	H2	ø S	E	R	Weight
					±0.015				[g]
TA-08	8	65	12	22	11	M5	52	32	40
TA-10	10	70	12	21	10.5	M5	55	34	37
TA-12	12	85	14	28	14	M6	70	42	70
TA-16	16	100	18	32	16	M8	82	54	130
TA-20	20	130	20	42	21	M10	108	72	220
TA-25	25	160	25	52	26	M12	132	88	440
TA-30	30	180	25	58	29	M12	150	96	560
TA-40	40	230	30	72	36	M16	190	122	1,000



Order example:

TA-10: floating shaft end support with inner Ø 10 mm

Shaft end supports, fixed



Order key

Type

Size

T A F - 08

Shaft end support

fixed

Inner Ø

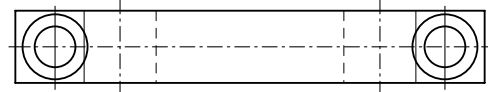
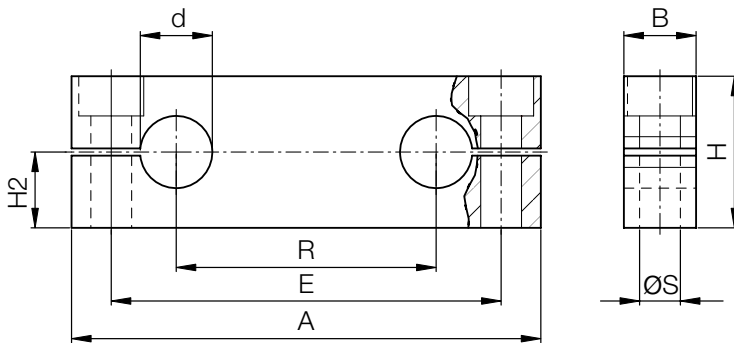
Material: aluminum
Through fixing hole

Dimensions [mm]

Part No.	d	A	B	H	H2	ø S	E	R	Weight
					±0.015				[g]
TAF-08	8	65	12	23	12.5	5.5	52	32	40
TAF-10	10	70	12	25	14.0	5.5	55	24	45
TAF-12	12	85	14	32	18.0	6.6	70	42	90
TAF-16	16	100	18	36	20.0	9.0	82	54	140
TAF-20	20	130	20	46	25.0	11.0	108	72	250
TAF-25	25	160	25	56	30.0	13.5	132	88	470
TAF-30	30	180	25	64	35.0	13.5	150	96	620
TAF-40	40	230	30	80	44.0	17.5	190	122	1,150



Order example:

TAF-12: fixed shaft end support with 12mm inner Ø

Shaft end blocks, standard design



Order key

Type

Size

W A - 08

Shaft end block
Standard design

Inner Ø

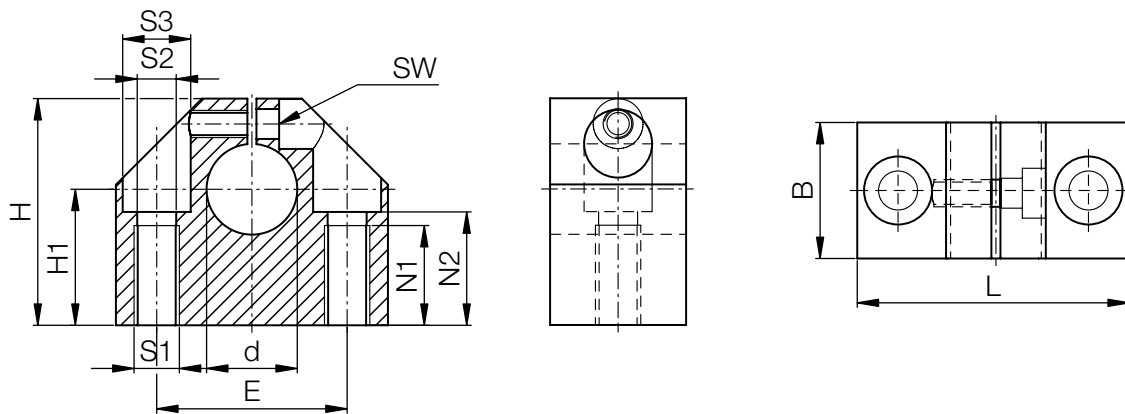

Material: aluminum

Dimensions [mm]

Part No.	d	B	H	H1	L	S1	S2	S3	E	N1	N2	SW	Weight [g]
WA-08	8	18	28	15	32	M4	3.3	6	22	9	13.0	2.5	40
WA-12	12	20	35	20	43	M6	5.2	10	30	13	16.5	3.0	100
WA-16	16	24	42	25	53	M8	6.8	11	38	18	21.0	4.0	150
WA-20	20	30	50	30	60	M10	8.6	15	42	22	25.0	5.0	230
WA-25	25	38	60	35	78	M12	10.3	18	56	26	30.0	6.0	410
WA-30	30	40	70	40	87	M12	10.3	18	64	26	34.0	6.0	530
WA-40	40	48	90	50	108	M16	14.25	20	82	34	44.0	8.0	990
WA-50	50	58	105	60	132	M20	17.5	26	100	43	49.0	10.0	1,250
WA-60	60	74	130	75	164	M27	22	33	124	43	59.0	10.0	2,950



Order example:

WA-08: shaft end block, standard design with inner Ø 8mm

Shaft end blocks, compact design

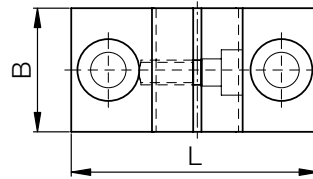
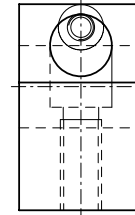
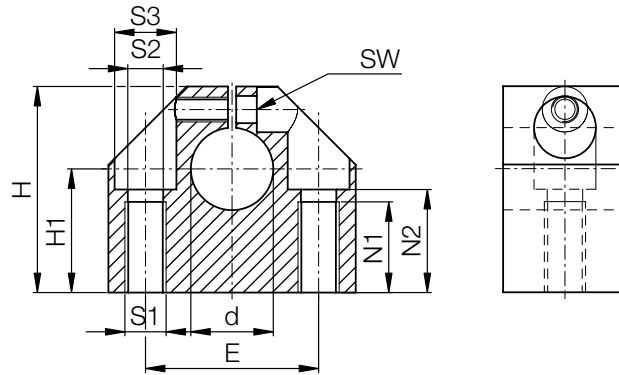

Order key

Type Size

W A C - 06

Shaft end block	Compact design	Inner Ø
-----------------	----------------	---------



Material: aluminum

Dimensions [mm]

Part No.	d	B	H	H1	L	S1	S2	S3	E	N1	N2	SW	Weight [g]
				from +0.01 to +0.02					±0.1				
WAC-06	6	16	27	15	32	M5	4.2	8	22	11	13	2.5	30
WAC-08	8	16	27	16	32	M5	4.2	8	22	11	13	2.5	30
WAC-10	10	18	33	18	40	M6	5.2	10	27	13	16	3.0	50
WAC-12	12	18	33	19	40	M6	5.2	10	27	13	16	3.0	50
WAC-14	14	20	38	20	45	M6	5.2	10	32	13	18	3.0	70
WAC-16	16	20	38	22	45	M6	5.2	10	32	13	18	3.0	70
WAC-20	20	24	45	25	53	M8	6.8	11	39	18	22	4.0	120
WAC-25	25	28	54	31	62	M10	8.6	15	44	22	26	5.0	170
WAC-30	30	30	60	34	67	M10	8.6	15	49	22	29	5.0	220
WAC-40	40	40	76	42	87	M12	10.3	18	66	26	38	6.0	480
WAC-50	50	50	92	50	103	M16	14.25	20	80	34	46	8.0	820



Order example:

WAC-12: shaft end block, compact design with inner Ø 12mm

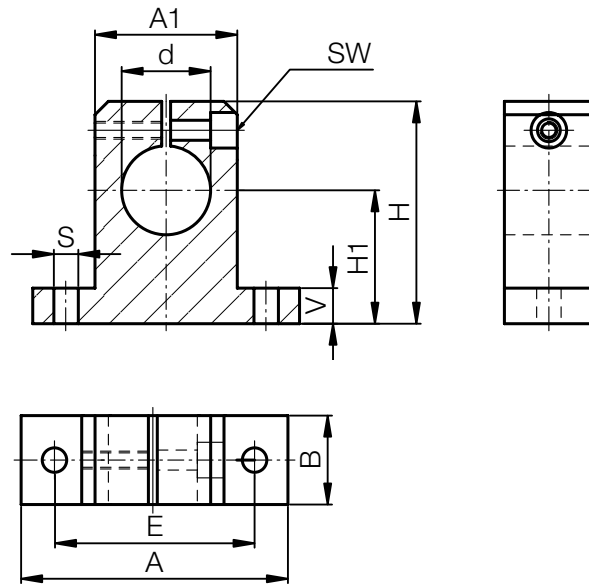

Order key

Type

Size

W A S - 08

Shaft end block

Narrow design

Inner Ø



Material: aluminum

Dimensions [mm]

Part No.	d	H	H1 ±0.02	A	A1	B	E	S	V	SW	Weight [g]
WAS-08	8	27	15	32	16	10	25	4.5	5.0	2.5	12
WAS-12	12	35	20	42	20	12	32	5.5	5.5	3.0	23
WAS-16	16	42	25	50	26	16	40	5.5	6.5	3.0	35
WAS-20	20	50	30	60	32	20	45	5.5	8.0	4.0	67
WAS-25	25	58	35	74	38	25	60	6.6	9.0	4.0	140
WAS-30	30	68	40	84	45	28	68	9.0	10.0	5.0	200
WAS-40	40	86	50	108	56	32	86	11.0	12.0	6.0	480



Order example:

WAS-12: shaft end block, narrow design with inner Ø 12mm

Flanged shaft end block

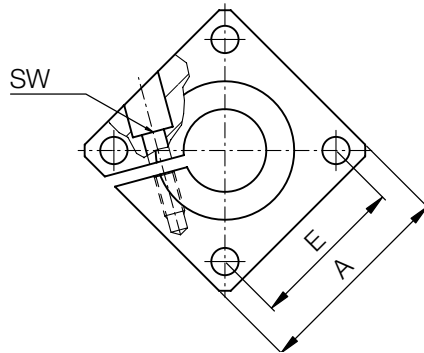
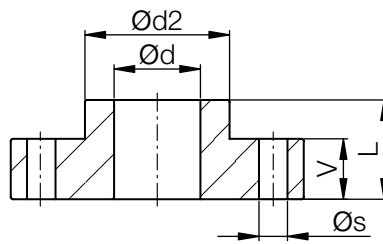

Order key

Type

Size

WAF - 12

Shaft end block

With flange

Inner Ø



Material: aluminum

Dimensions [mm]

Part No.	$\varnothing d$	A	L	$\varnothing d2$	E	$\varnothing s$	V	SW	Weight [g]
WAF-12	12	40	20	23.5	30 ± 0.12	5.5	12	3	60
WAF-16	16	50	20	27.5	35 ± 0.12	5.5	12	3	80
WAF-20	20	50	23	33.5	38 ± 0.15	6.6	14	4	100
WAF-25	25	60	25	42.0	42 ± 0.15	6.6	16	5	150
WAF-30	30	70	30	49.5	54 ± 0.15	9.0	19	6	300
WAF-40	40	100	40	65.0	68 ± 0.25	11.0	26	8	700
WAF-50	50	100	50	75.0	75 ± 0.25	11.0	36	8	1,200



Order example:

WAF-16: Flange shaft support with inner \varnothing 16mm

drylin® linear guides expert

With the drylin® linear guides expert, you can configure a linear guide to suit your particular application and, at the same time, calculate its service life. After this, you can simply order your configuration online or request further information.

Select series

 <p>drylin® T Profile guide rail system</p> <ul style="list-style-type: none"> • Max. load capacity up to 14,000 N • Widths from 17 mm to 80 mm • Installation dimensions from 8 mm to 42 mm • Temperature from -40°C to 90°C • Adjustable clearance <p>Select</p>	 <p>drylin® N Low-profile guide</p> <ul style="list-style-type: none"> • Max. load capacity up to 1,000 N • Widths from 17 mm to 80 mm • Installation dimensions from 8 mm to 12 mm • Temperature from -40°C to 90°C • Low weight <p>Select</p>	 <p>drylin® W Modular guide system kit</p> <ul style="list-style-type: none"> • Max. load capacity up to 12,000 N • Temperature from -40°C to 90°C • Quick and easy assembly • Insensitive to dust & dirt • Low installation height • Easy installation <p>Select</p>
 <p>drylin® B Shaft guide</p> <ul style="list-style-type: none"> • Max. load capacity up to 70,000 N • Diameters from 8 mm to 80 mm • Temperature from -100°C to 230°C • Round and supported shafts • 8 shaft materials • Replaceable with ball bearings <p>Select</p>		

Expert for linear guides: System selection and service life calculation with CAD

Configure linear bearings and calculate their service life – constantly expanded by new sizes and products

Easily calculate the service life of your required linear guide and configure with a few clicks. Select a drylin® system and add the relevant environmental parameters. Select the bearing size, carriage, number and position. Then enter the distance between the rails and the mounting. Define more relevant parameter of the guidance and select a rail length. The results are displayed.



► www.igus.com/drylin-expert



Download the online tool app now



Aluminum shafts in combination with iglide® J enable high speeds due to the lightweight.

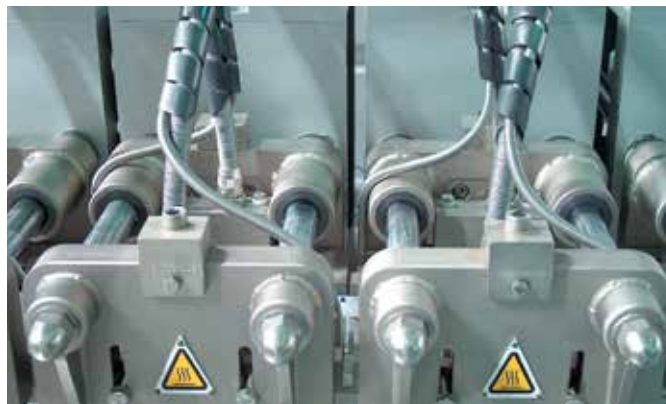

Stainless steel shafts combined with iglide® X, offer maximum resistance at +248 °F. Cleaning in filling machine.



Stainless steel combined with iglide® J in cut-off grinding machine. Grinding particles and coolants, extreme conditions.



Cost-effective guide for work piece carriage in a machine tool with supported aluminum shaft.

Subheading

Date:	Phone: 1-800-803-1895 Fax: 401-438-7680
From:	To: igus® Inc. Technical marketing drylin® linear technology P.O. Box 14349 East Providence, RI 02914
Phone:	
e-mail:	

Lower costs in 45 seconds? Simply fill in, send off, save!
Please send your machining requirement to sales@igus.com

Step 1: Please choose the required shaft material



Aluminum, hard-anodized



Cf53 hardened steel,
AISI 1055



Hardened stainless steel
AISI 420C



Stainless steel,
AISI 304



CF53 hard-chromed steel
AISI 1055



Hardened stainless steel
AISI 440B



Stainless steel,
AISI 316Ti

Step 2: Please choose the required shaft version



Standard design



Low level supported



Standard supported

Support material

Aluminum

Stainless steel

Step 3: Please enter the required dimensions.

Outer Ø (mm)

Length (mm)

Step 4: Please draw a sketch of the required machining.



1 Chamfer

2 Spanner flat

3 Machined end

4 Groove recesses axial

5 Male threads, axial

6 Female threads, axial

Female thread, radial

7 Other surfacing

one side

both sides

one side

both sides

one side

both sides

Quantity _____

one side

both sides

one side

both sides

Quantity _____

one side

both sides

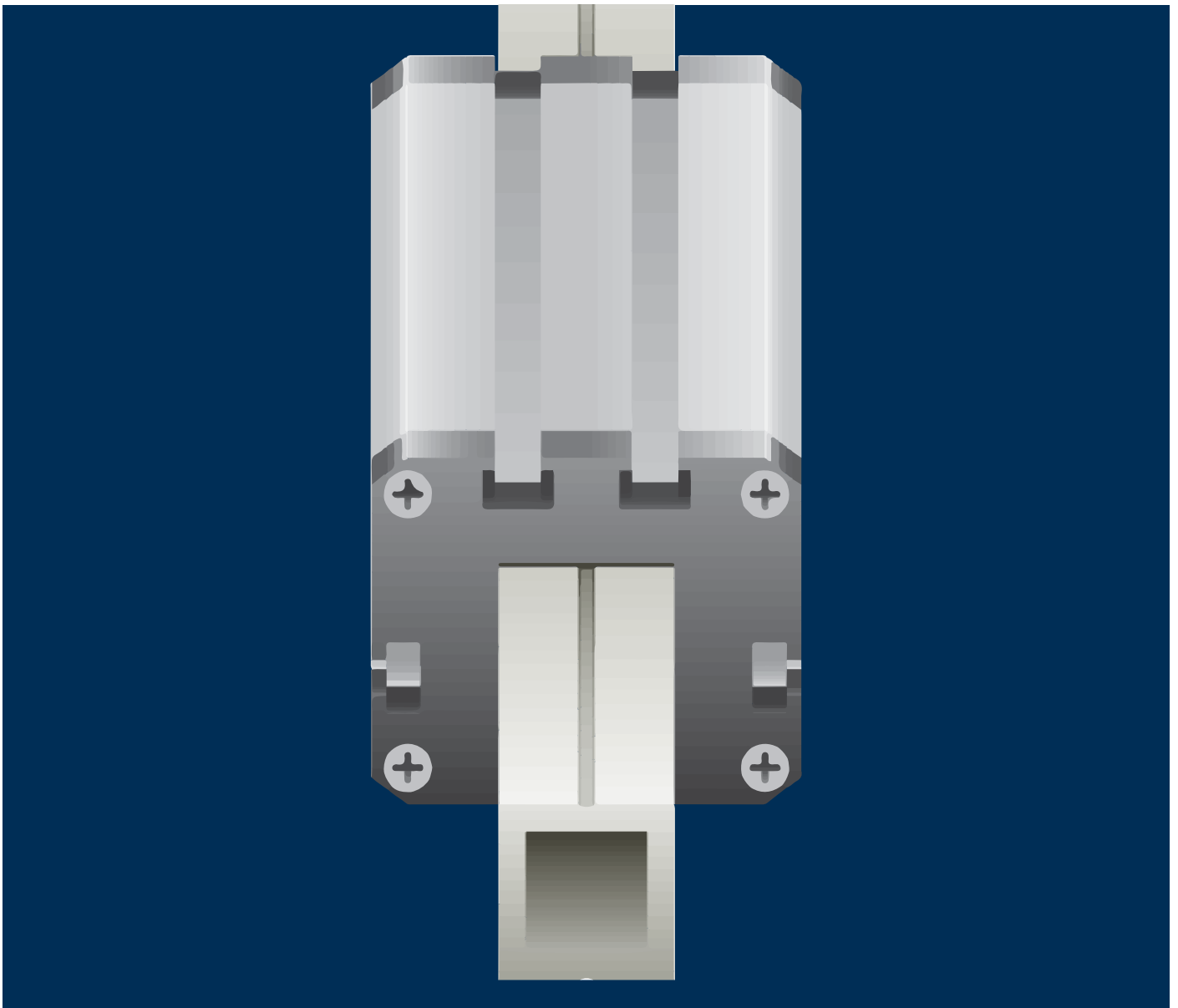

drylin[®] linear technology – drylin[®] Q square linear guides

Torque-resistant linear guides

Square section linear rail made from hard-anodized aluminum

Resists moments up to 10Nm

Adjustable linear carriage with or without manual clamp

Self-lubricating and lightweight



drylin® Q square linear guides | Advantages

Torque-resistant, space-saving, light, unsupported installation

Self-lubricating square linear guides - DryLin® Q

Linear movement with torque resistance, completely self-lubricating. The DryLin® Q linear system offers maximum flexibility in design. Individual housing options such as solid plastic bearings and adjustable systems with and without manual clamp are available. Due to the hollow design, the durable hard-anodized aluminum profile is very light and is suitable for the installation of supply cables. Options for mounting are extensive, among others, using slot nuts; size 20 can also be combined with all 20/20 aluminum framing profile kits.

- 100% self-lubricating
- Torque resistant
- Adjustable clearance
- Applied forces from all directions possible
- Dirt resistance
- Quiet

Typical industries:

- Lab devices
- Monitor adjustment
- Machine building
- Automation



Available from stock

Detailed information about delivery time online.



Price breaks online

No minimum order value. No minimum order



Max. +194°F (+90°C)

Min. -40°F (-40°C)



3 sizes (10/12/20)

Rail length: 1500 to 4,000 mm

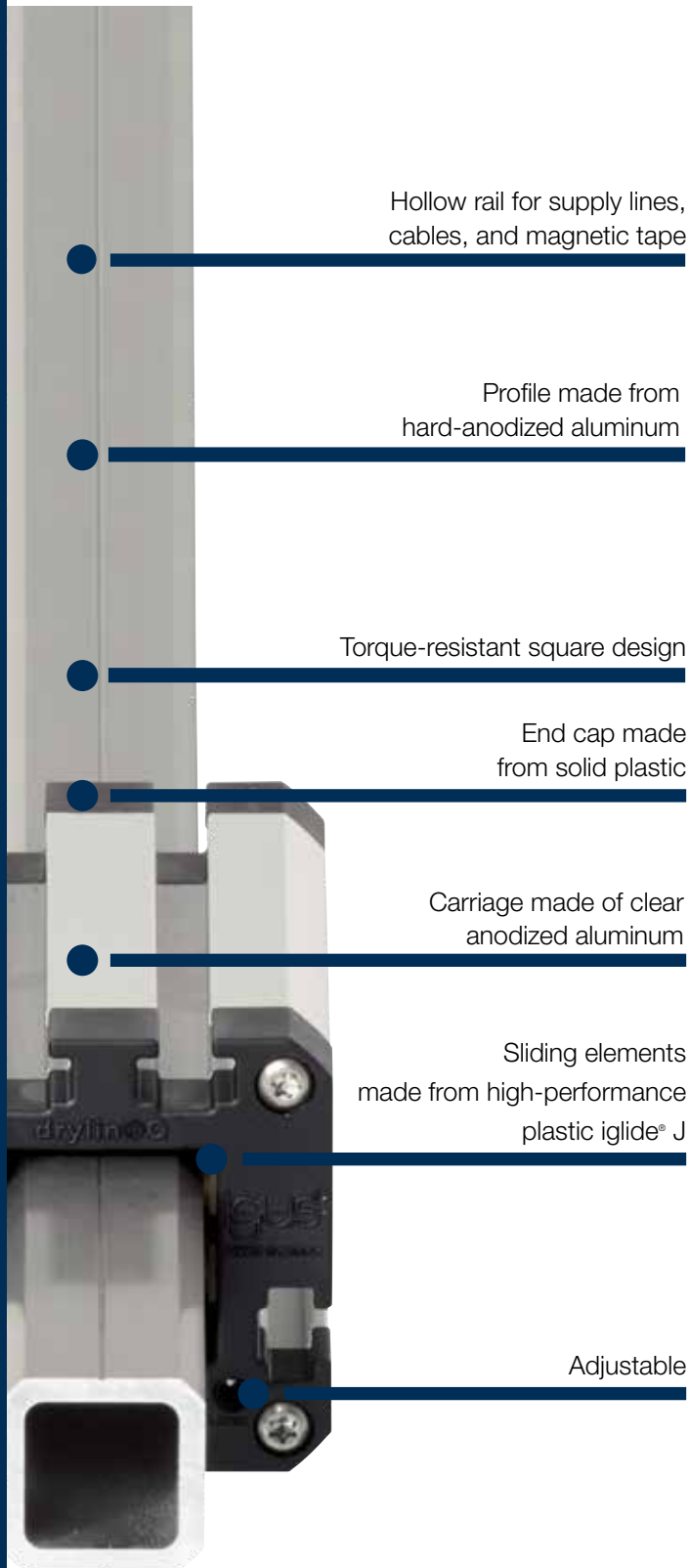

Technical details on floating bearings, 2:1 Rule, tightening torque for drylin® metallic screws ► Page 1097

drylin® Q square linear guides | Product overview

Linear system with individual housing versions



Square section linear rails

- Material: aluminum, hard-anodized
- Lightweight and corrosion-resistant
- Hollow rail design for cables feed-through

► Page 1352



Linear carriage

- Unsupported carriage version with/without manual clamp
- Numerous fastening options on all sides via slot nuts
- Bearing clearance adjustable

► Page 1353

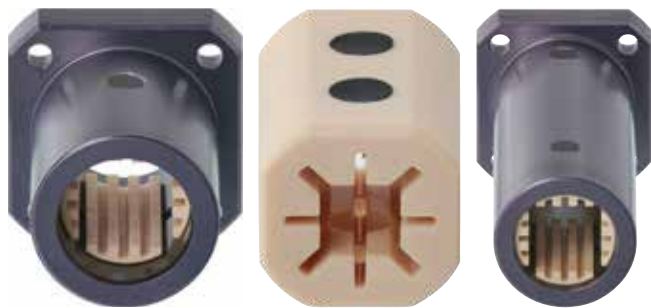

Bearing housing

- Enclosed anodized aluminum housing
- Apply moments up to 3Nm (size 10), 10Nm (size 20)
- Torque-resistant sliding elements made from iglide® J

► Page 1355



Accessories

- Supports made from plastic and end caps for aluminum profiles
- Adapter kit for grippers and sensors
- Adapter for igus® e-chains® series E2 micro

► Page 1358



Measuring systems

drylin® QKM

► Page 1371

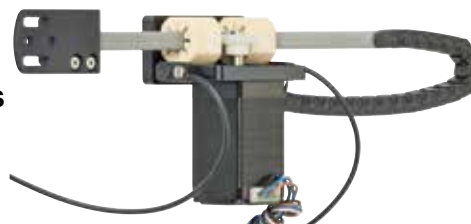

Cantilever axis

drylin® GRQ miniature linear module

► Page 1645

drylin® Q square linear guides | Product Range

Square section linear rails

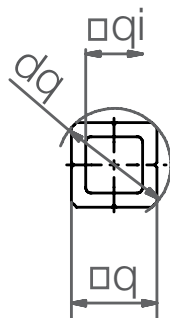

Order key

Type Size Option

AWMQ - 10 - 1000

Aluminum shaft	Metric	Type square	Installation size	Length [mm]
----------------	--------	-------------	-------------------	-------------

Dimensions [mm]

Part No.	Weight [kg/m]	q	dq	qi ±0.02	Max. length
AWMQ-10	0.082	7.5	10	5	1,500
AWMQ-12	0.193	12	8.5	16	1,500
AWMQ-20	0.46	20	25	15	3,000

Accessories

Plastic end supports



Plastic guide-rail end caps



- Cost-effective mounting options

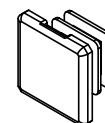
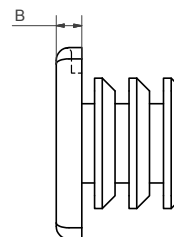
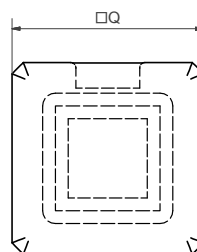
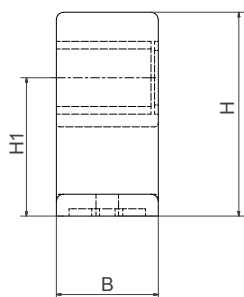
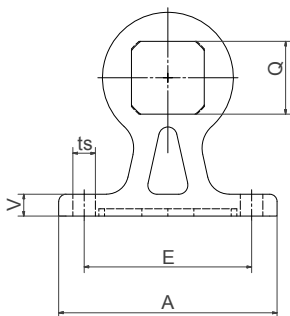

Dimensions [mm]

Part No.	A	H	B	Q	H1	E	ts	V
STZ-Q10-01-FL	30	21	14	7.5	14	20	3.3	3
STZ-Q20-01-FL	60	56	28	20	38	46	6.2	6

Dimensions [mm]

Part No.	Q	B
STZ-Q10-01-C	7.5	1
STZ-Q20-01-C	20	5

drylin® Q square linear guides | Product Range

Adjustable linear carriage

drylin® Q
square
linear
guides



Order key

Type

Size

QWE - 01 - 20

Square

Linear carriage

Adjustable

Type standard

Installation size

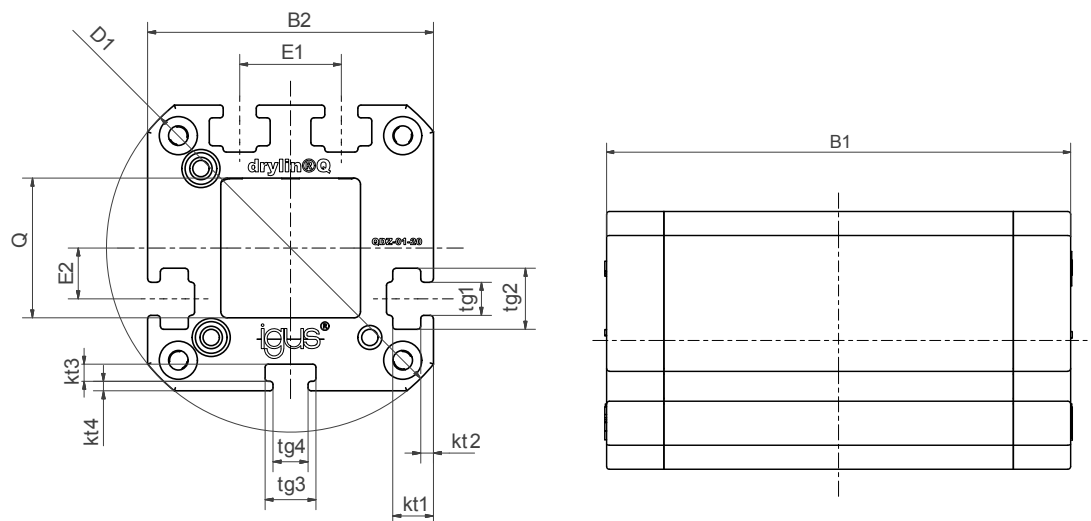

Dimensions [mm]

Part No.	Weight [g]	M max. [Nm]	B1	B2	D1	Q	E1	E2	tg1	tg2	tg3	tg4	kt1	kt2	kt3	kt4
QWE-01-12	110	5	80	34	44	12	12	6	5.5	8	8	-	-	-	3	1.25
QWE-01-20	210	10	81	45	58	20	16	8	5.5	9.6	8	5.5	6.4	2	2.7	1.5

Accessories: Slot nuts



Slot nuts offer mounting options on four sides of the housing. 8 pieces are included in the delivery of QWE carriages.

Part No. NOR-20602

Can be combined with:



AWMQ-12



AWMQ-20

drylin® Q square linear guides | Product Range

Adjustable linear carriage with manual clamp



Order key

Type Size Options

Q W E - 01 - 20 - HKA

Square	Linear carriage	Adjustable	Type standard	Installation size	Manual clamp
--------	-----------------	------------	---------------	-------------------	--------------

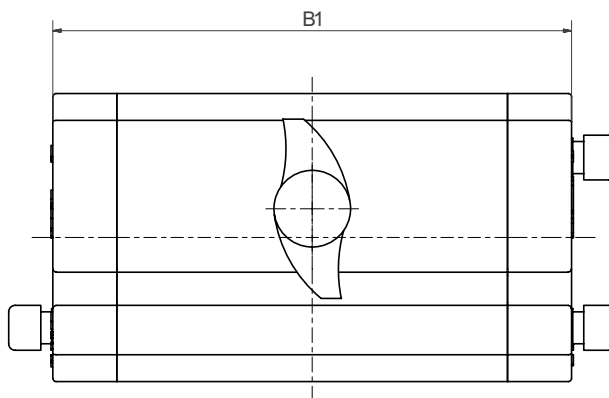
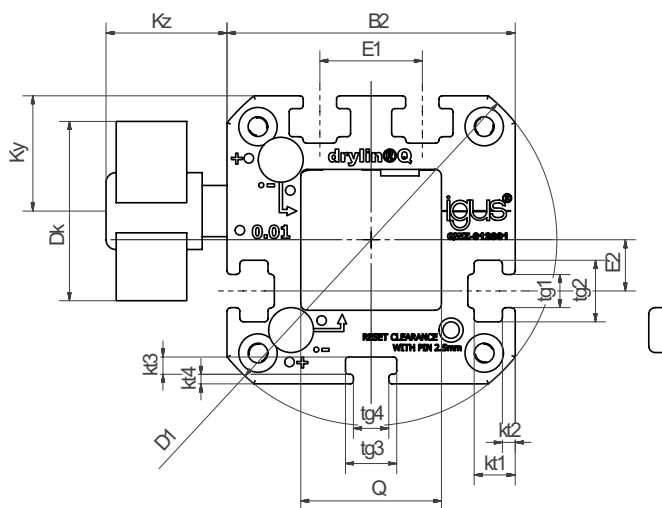

Dimensions [mm]

Part No.	Weight [g]	M max. [Nm]	B1	B2 h7	D1	Q	E1	E2	tg1	tg2	tg3	tg4
QWE-01-12-HKA	-	-	80	34	44	12	12	6	5.5	8	8	-
QWE-01-20-HKA	215	10	81	45	58	20	16	8	5.2	9.6	8	5.5

Part No.	kt1	kt2	kt3	kt4	Dk	Ky	Kz
QWE-01-12-HKA	-	-	3	1.25	18	14	19
QWE-01-20-HKA	6.4	2	2.7	1.5	28	18	19



The manual clamp has been developed for simple tasks. The creep behavior of the clamped plastic causes a reduction in the clamping force over time (up to 70%). They should not be used in safety-related applications.

Can be combined with:



AWMQ-20

drylin® Q square linear guides | Product Range

Q20 pillow blocks



Order key

Type Size

Q J R M T - 05 - 20

Square	iglide® J	Closed design	Metric	Twin (optional)	Type compact	Installation size
--------	-----------	---------------	--------	-----------------	--------------	-------------------

QJRM-05-20

QJRMT-05-20

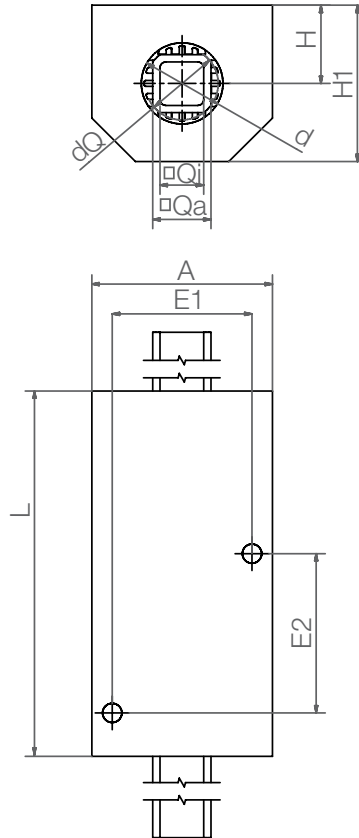
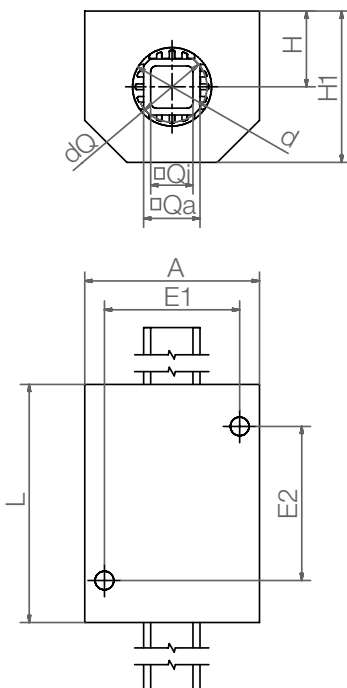

Dimensions [mm]

Part No.	Weight [kg]	A	H ±0.02	H1	dQ	Qa	Qi	E1 ±0.15	E2 ±0.15	d	L
QJRM-05-20	0.25	62	27	54	25	20	15	48	–	28	40
QJRMT-05-20	0.55	62	27	54	25	20	15	48	55	28	85

Can be combined with:



AWMQ-20

drylin® Q square linear guides | Product Range

With flange



QJFM-02-...



QJFMT-01-...



Order key

Type	Option	Size
Q J F M T - 02 - 10		
Square	iglide® J	
With flange	Metric	
Tandem (optional)	Design	
		Installation size

Options:

01 = Round flange

02 = Square flange

QJFM-01

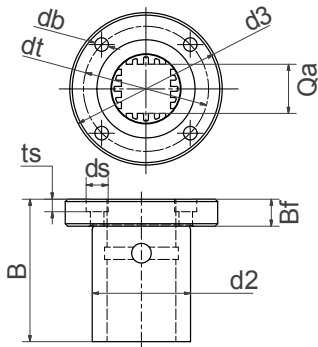

QJFM-02

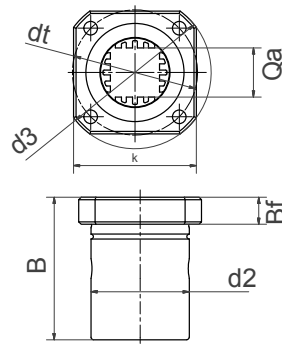

QJFMT-01

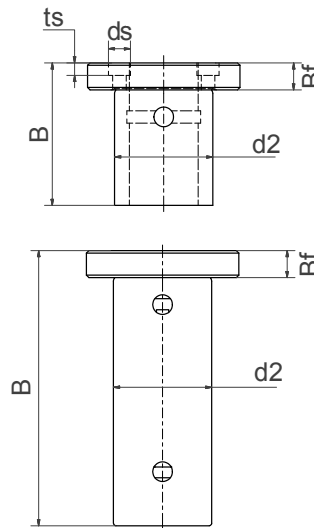

QJFMT-02

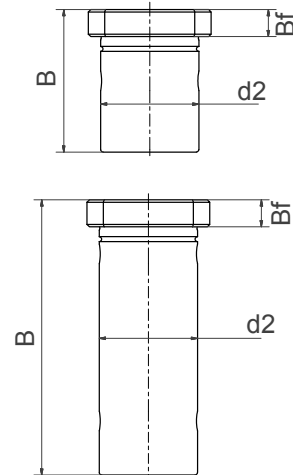

Dimensions [mm]

Part No.	Weight [kg]	k	d2 h7	Bf	Qa	d3 ±0.15	dt ±0.15	B	db	ds	ts
QJFM-01-20	0.14	-	40	11	20	62	51	58	5.5	9.0	5.1
QJFM-02-20	0.14	50	40	11	20	62	51	58	5.5	9.0	5.1
QJFMT-02-10	0.038	30	19	9	7.5	39	29	52	4.5	7.5	4.1
QJFMT-01-20	0.24	-	40	11	20	62	51	112	5.5	9.0	5.1
QJFMT-02-20	0.24	50	40	11	20	62	51	112	5.5	9.0	5.1

Can be combined with:



AWMQ-10



AWMQ-20

drylin® Q square linear guides | Product Range

Q10 pillow blocks

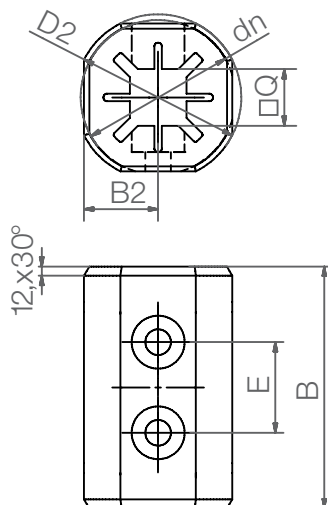
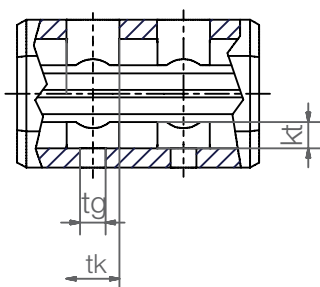

Order key

Type QJRMP-01-10 Size

QJRMP-01-10

Square	iglide® J	Closed design	Metric	Solid plastic	Standard design	Installation size
--------	-----------	---------------	--------	---------------	-----------------	-------------------



Manual clamp available.
Suffix "-HKA"

Dimensions [mm]

Part No.	Weight [g]	M max. [Nm]	B	B2	D2	dn	E	Q	tk	tg	kt
QJRMP-01-10	11.3	3	32	9.8	22	22	12	7.5	6	3.4	3.5

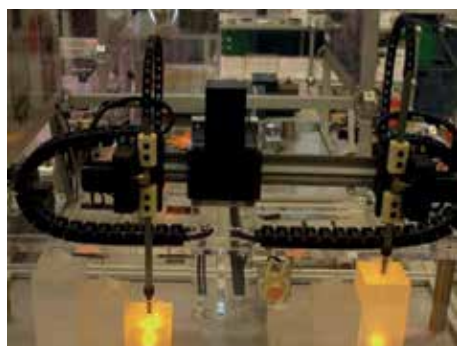

Pipette unit equipped with drylin® Q square linear guide combined with drylin® GRW gear rack-driven actuator

Can be combined with:



AWMQ-10

drylin® Q square linear guides | Product Range

Accessories



- Hollow rail for supply lines (compressed air, cable)
- Small space requirement

Single components



Adapter for flange shaft block



Part No.
STZ-Q10-AR-1012-16



Adapter kit e.g. for grippers/sensors



Part No.
STZ-Q10-01-AM



Plastic shaft end supports



Part No.
STZ-Q10-01-FL
STZ-Q10-01-LL



Chain connection for e-chain® E2 micro



Part No.
STZ-Q10-01-AC-E2



End caps for square-section rail



Part No.
STZ-Q10-01-C
STZ-Q20-01-C



drylin® stop motion linear guides

Infinite positioning

Consistent, smooth drive forces

Maintains position

Holding force up to 11.7N

Various preload options



drylin® Stop motion linear guides | Advantages

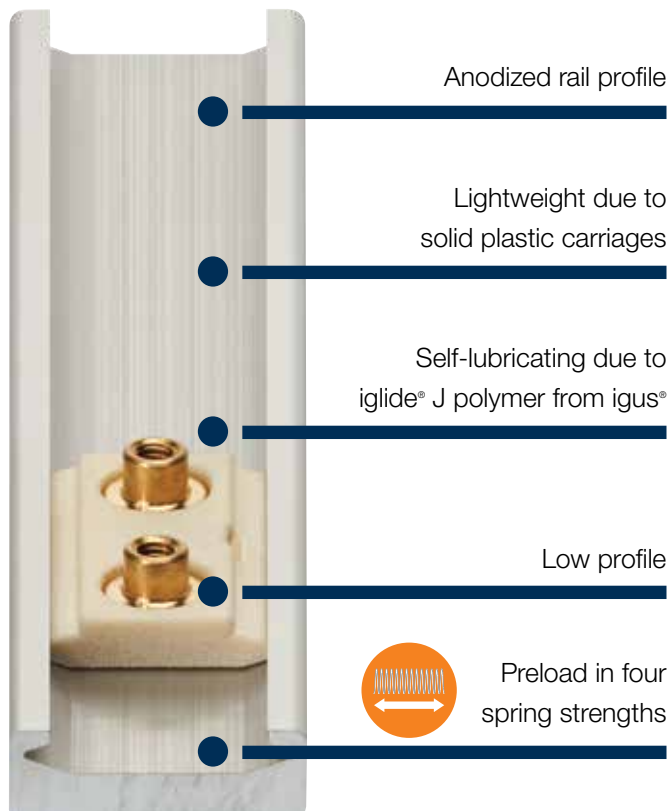

Self-lubricating drylin® stop motion linear guides

Self-lubricating drylin® stop motion linear guides provide a guaranteed holding force. The preload can be selected among 4 forces for all linear carriages and bearings. This enables a precise and consistent adjustment without any stick-slip effect. The preload class selection enables constant drive forces throughout its lifetime and the carriage holds the load in place.

- Easy positioning of carriage
- Guaranteed drive force and holding force
- Lightweight low-profile

Typical application areas

- Seats adjustments (headrests, armrests, leg rests, etc.)
- Measuring devices and microscopes
- Furniture
- Gripper for automation and handling



Available from stock

Detailed information about delivery time online.



Price breaks online

No minimum order value. No minimum order quantity.



Rail profiles cut to your required length



Product finder

► www.igus.com/drylin-expert

drylin® preload prism slides



- Standard prism carriages with individual preload
 - For variable distances
 - 4 preload classes
 - With threaded pin or through hole
- Page 1363



- Long prism carriage with dual preload
 - More stable guide length
 - 4 preload classes
 - With threaded pin or through hole for mounting
- Page 1365



- Corrosion-resistant anodized aluminum
 - With standard mounting holes or without holes
 - Prism geometry for higher holding force
- Page 1362 / 1364

drylin® W stop motion



- drylin® W single bearing housings with variable spring preload
 - For consistent adjustments
 - For constant driving forces
- Page 1366

- Durable, cost-effective zinc die-cast housings
- Lightweight anodized aluminum options
- Stainless steel options
- Linear plain bearings made from iglide® J200/J, T500 (X)*



- Suitable for all drylin® W single and double shafts with round geometry
 - Corrosion-resistant with drylin® stainless steel rails
- From page 1112

drylin® W stop motion positional system

For accurate positioning at defined points. With a lightweight design and a torsionally rigid profile rail, the holding force can be determined by means of preloaded balls and/or the shape and position of the hole.

- For manual adjustment
 - Ideal for adjusting headrests, armrests and leg rests
 - Lightweight due to plastic and aluminum
- www.igus.com/stopmotion



*European part numbers for the high temperature liner begin with X. Example XUI-...

drylin® Stop motion linear guides | Product Range

Prism rails



Standard

Without holes



Order key

Type Installation size Options

NSV - 01 - 27 - S

Guide rails for
preload prism slide

Type

Installation size

Without holes

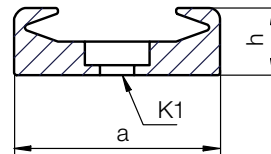
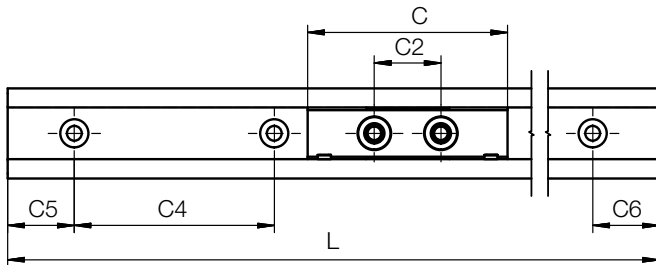

Guide rail – dimensions [mm]

Part No.	C	C2	h	L	C4	C5	C6	a	K1	ly	lz	Weight
	Carriage length	Carriage hole distance on center	Rail height	Length Max.		Min.	Max.	Rail width		[mm']	[mm']	[g/m]
NSV-01-27	35	20	8.8	3,000	60	20	49.5	27	Ø4.5	11,250	766	409
NSV-01-27-S ^{7a}	35	20	8.8	3,000	-	-	-	27	-	11,250	766	409

^{7a} For rails without mounting holes, please use part number suffix "S"

^{7a} Please give the required length in mm, symmetrical standard hole pattern C5=C6

drylin® Stop motion linear guides | Product Range

Preload prism slide, standard design

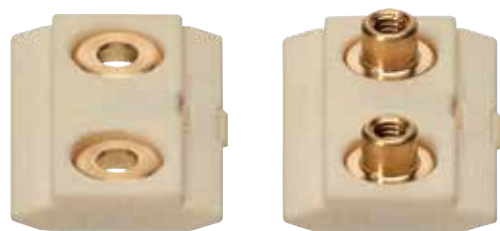

Type 21

Type 22

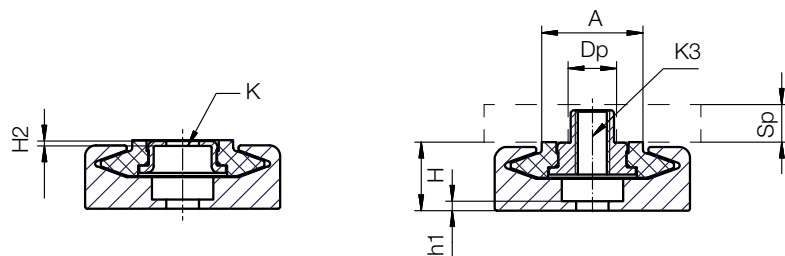

Order key

Type	Installation size	Options		
NWV - 21 - 27 - 35 - P05				
Preload prism slide	Type of carriage	Rail width	Carriage length	Preload

Guide carriage – dimensions [mm]

Part No.	Preload [N]	A	H ±0.35	h1	H2	K	K3	M ⁷⁵⁾ [Nm]	Sp Min.	Dp ¹⁵⁹⁾	Weight [g]
NWV-21-27-35-P05	5	14	9.5	1.1	0.7	Ø4.5	–	–	–	–	6
NWV-21-27-35-P11	11	14	9.5	1.1	0.7	Ø4.5	–	–	–	–	6
NWV-21-27-35-P23	23	14	9.5	1.1	0.7	Ø4.5	–	–	–	–	6
NWV-21-27-35-P38	38	14	9.5	1.1	0.7	Ø4.5	–	–	–	–	6
NWV-22-27-35-P05	5	14	9.5	1.1	–	–	M4	1.2	5	5	11
NWV-22-27-35-P11	11	14	9.5	1.1	–	–	M4	1.2	5	5	11
NWV-22-27-35-P23	23	14	9.5	1.1	–	–	M4	1.2	5	5	11
NWV-22-27-35-P38	38	14	9.5	1.1	–	–	M4	1.2	5	5	11

⁷⁵⁾ Max. screw tightening torque

¹⁵⁹⁾ Hole min. Ø

Part No.	Average displacement force	Guaranteed holding force
	[N]	[N]
NWV-21/22-27-35 P05	1.0	0.5
NWV-21/22-27-35 P11	2.2	1.1
NWV-21/22-27-35 P23	4.6	2.3
NWV-21/22-27-35 P38	7.6	3.8



Note:

The average displacement force values apply to unloaded carriages at centric drive. The real displacement forces depend to a large extent on the displacement speed. At creep movement (few mm/min.), the values are slightly over the guaranteed holding force. At higher displacement forces, the values can considerably exceed the average displacement force. The values do not apply for applications in which dirt and moisture ingress into the system.

drylin® Stop motion linear guides | Product Range

Prism rails



Standard

Without holes



Order key

Type Installation size Options

NSV - 01 - 27 - S

Guide rails for
preload prism slide

Type

Installation size

Without holes

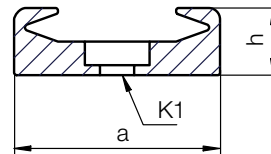
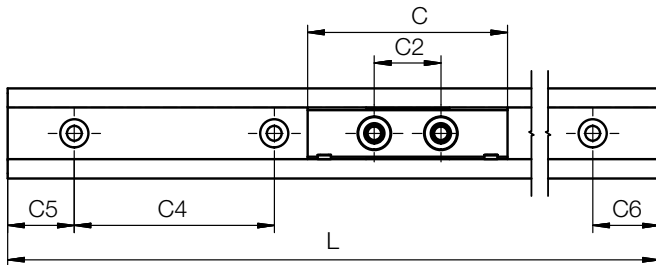

Guide rail – dimensions [mm]

Part No.	C	C2	h	L	C4	C5	C6	a	K1	ly	lz	Weight
	Carriage length	Carriage hole distance on center	Rail height	Length Max.		Min.	Max.	Rail width		[mm']	[mm']	[g/m]
NSV-01-27	60	20	8.8	3,000	60	20	49.5	27	Ø4.5	11,250	766	409
NSV-01-27-S ^{7a}	60	20	8.8	3,000	-	-	-	27	-	11,250	766	409

^{7a} For rails without mounting holes, please use part number suffix "S"

^{7a} Please give the required length in mm, symmetrical standard hole pattern C5=C6

Preload prism slide, long design



Type 21

Type 22

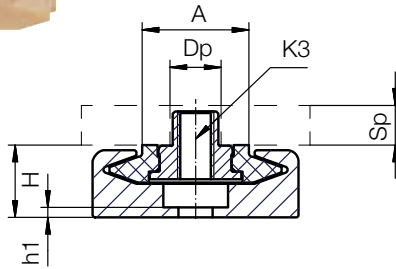
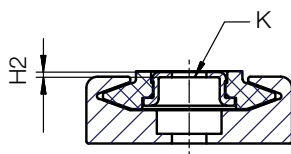

Order key

Type Installation size Options

NWV - 21 - 27 - 60 - P10

Preload prism slide	Type of carriage	Rail width	Carriage length	Preload
---------------------	------------------	------------	-----------------	---------

Guide carriage – dimensions [mm]

Part No.	Preload [N]	A	H ±0.35	h1	H2	K	K3	M ⁷⁹⁾ [Nm]	Sp Min.	Dp ¹⁹⁹⁾	Weight [g]
NWV-21-27-60-P10	1.0	14	9.5	1.1	0.7	Ø4.5	–	–	–	–	10
NWV-21-27-60-P22	2.2	14	9.5	1.1	0.7	Ø4.5	–	–	–	–	10
NWV-21-27-60-P46	4.6	14	9.5	1.1	0.7	Ø4.5	–	–	–	–	10
NWV-21-27-60-P76	7.6	14	9.5	1.1	0.7	Ø4.5	–	–	–	–	10
NWV-22-27-60-P10	1.0	14	9.5	1.1	–	–	M4	1.2	5	6.5	13
NWV-22-27-60-P22	2.2	14	9.5	1.1	–	–	M4	1.2	5	6.5	13
NWV-22-27-60-P46	4.6	14	9.5	1.1	–	–	M4	1.2	5	6.5	13
NWV-22-27-60-P76	7.6	14	9.5	1.1	–	–	M4	1.2	5	6.5	13

⁷⁹⁾ Max. screw tightening torque

¹⁹⁹⁾ Hole min. Ø

Part No.	Average displacement force	Guaranteed holding force
	[N]	[N]
NWV-21/22-27-60-P10	2.0	1.3
NWV-21/22-27-60-P22	4.4	4.2
NWV-21/22-27-60-P46	9.2	6.2
NWV-21/22-27-60-P76	15.2	11.7



Note:

The average displacement force values apply to unloaded carriages at centric drive. The real displacement forces depend to a large extent on the displacement speed. At creep movement (few mm/min.), the values are slightly over the guaranteed holding force. At higher displacement forces, the values can considerably exceed the average displacement force. The values do not apply for applications in which dirt and moisture ingress into the system.

drylin® Stop motion linear guides | Product Range

Pillow blocks, round, with spring preload

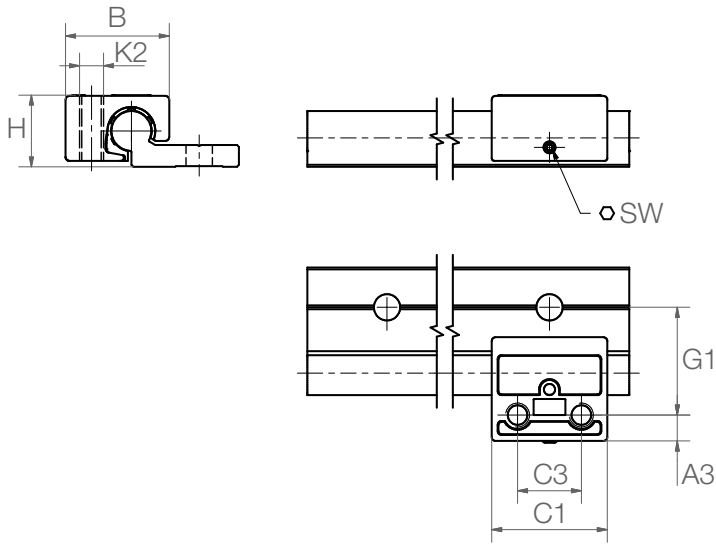

Technical data and dimensions [mm]

Part No.	Preload	Weight		B	C1	C3	A3	K2	H	SW	G1	
		-ES	-AL									
	[N]	[g]	[g]	[g]					±0.25			
WJ200UM-01-10-□-P40	4	43	56	19	26	29	16	6.5	M6	18	1.5	27
WJ200UM-01-10-□-P90	9	43	56	19	26	29	16	6.5	M6	18	1.5	27
WJ200UM-01-10-□-P140	14	43	56	19	26	29	16	6.5	M6	18	1.5	27
WJ200UM-01-16-□-P40	4	110	132	46	34.5	36	18	9	M8	27	2.5	33
WJ200UM-01-16-□-P90	9	110	132	46	34.5	36	18	9	M8	27	2.5	33
WJ200UM-01-16-□-P140	14	110	132	46	34.5	36	18	9	M8	27	2.5	33
WJ200UM-01-16-□-P230	23	110	132	46	34.5	36	18	9	M8	27	2.5	33
WJ200UM-01-20-□-P40	4	222	275	95	42.5	45	27	9	M8	36	2.5	38
WJ200UM-01-20-□-P90	9	222	275	95	42.5	45	27	9	M8	36	2.5	38
WJ200UM-01-20-□-P140	14	222	275	95	42.5	45	27	9	M8	36	2.5	38
WJ200UM-01-20-□-P230	23	222	275	95	42.5	45	27	9	M8	36	2.5	38



Order key

Type	Size	Material
------	------	----------

WJ200UM-01-16-□-P40

drylin® W	Liner material iglide® J200	Pillow block, round	Standard	Size	Housing material	Preload
-----------	--------------------------------	---------------------	----------	------	------------------	---------

Blank =

Zinc die-casting

AL =

Aluminum

ES =

Stainless steel

(AISI 316Ti, machined)

Suitable drylin® W rails Single rails / double rails / high profile



WS-10
WS-16
WS-20



WS-10-30
WS-10-40
WS-10-80
WS-10-120
WS-16-60
WS-20-80



WS-10-ES-FG
WS-16-ES-FG
WS-20-ES-FG



WS-10-40-ES-FG



WSX-10-40
WSX-10-80
WSX-16-60

drylin® Stop motion linear guides | Product Range

Stop motion measuring system with rail scale

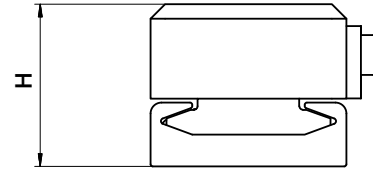
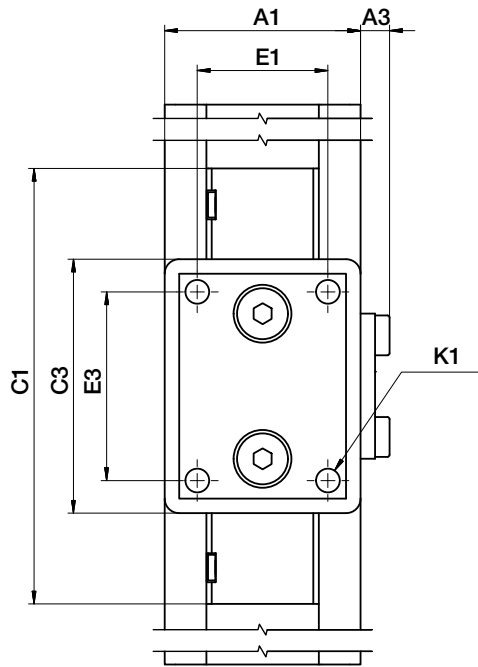

- econ measuring system based on drylin® preload prism slide
- Carriages with individually adjustable preload in 4 different strengths
- Including scaling on the rail
- Cost-effective, durable, practical
- Guaranteed holding force from 1.3N to 11.7N
- Due to stop motion preloading, the measuring system is suitable for vertical installation without any further clamping

Typical application areas:

- Mechanical engineering
- Format adjustment
- Crafts

Dimensions [mm]

Part No.	H	C1	C3	E3	E1	A1	A3	K1
				±0.15	±0.15	±0.2		
NKV-27-MES	22.35	60	35	26	18	27	4	M4 11.8

drylin® Stop motion linear guides | Product Range

SLNV prism module for precise adjustment

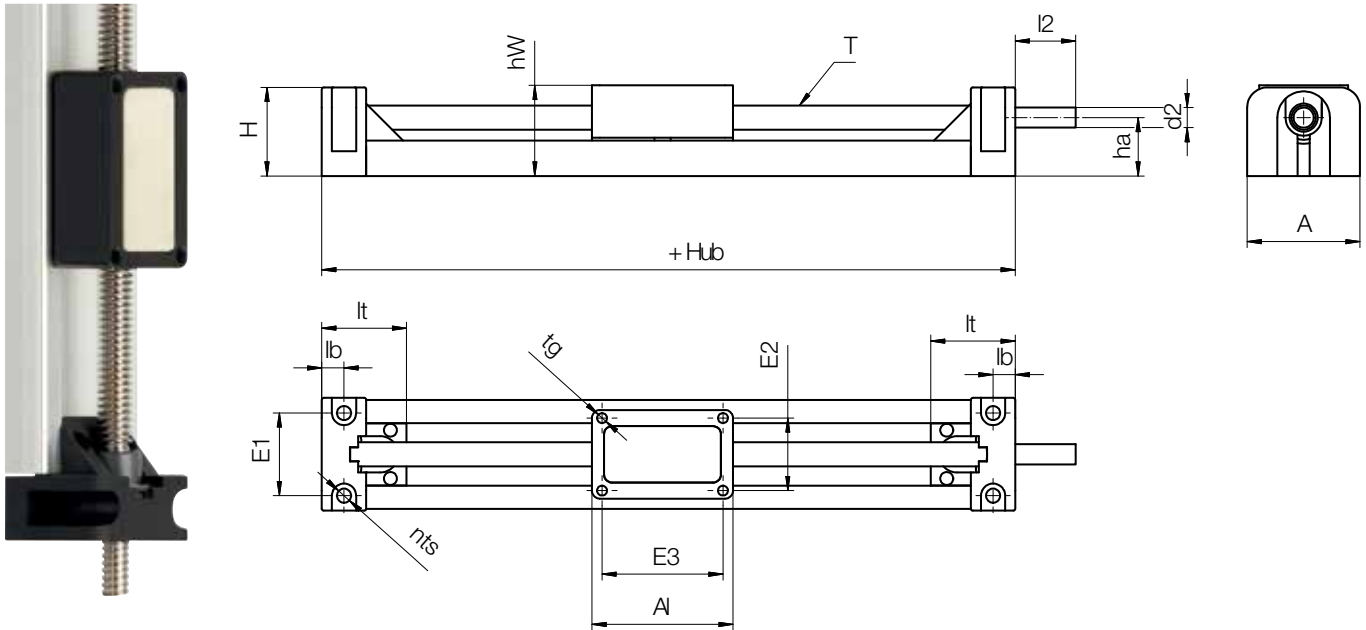

- SLNV linear module for the smaller applications
- For stroke lengths up to 250mm
- High precision due to stop motion preload prism slide
- Clearance reduction in z and y directions due to spring preload
- Lead screw with plain or ball bearing
- Feed rate up to 25.4mm per rotation

Typical application areas:

- Medical technology
- Dental equipment
- Research and development
- Measuring technology

Technical data

Part No.	Max. stroke length [mm]	Weight		Max. static load capacity		Max. speed	Max. drive torque [N]
		[kg]	Additional (per 100mm) [kg]	axial	radial		
SLNV-27-0025	250	80	56	10	40	300	0.1
SLNV-27-0051	250	80	56	10	40	300	0.1
SLNV-27-0127	250	80	56	10	40	300	0.1
SLNV-27-0254	250	80	56	10	40	300	0.1

Dimensions [mm]

Part No.	A	A1	H	E1	E2	E3	I	hw	lt	lb	ts	tg	d2 ⁹⁸⁾ 4 h7	l2	ha
SLNV-27-0025	28	35	21.5	15	15	30	76	22.5	20.5	5	3.5	6.35x2.54	5	15	14
SLNV-27-0051	28	35	21.5	15	15	30	76	22.5	20.5	5	3.5	6.35x5.08	5	15	14
SLNV-27-0127	28	35	21.5	15	15	30	76	22.5	20.5	5	3.5	6.35x12.7	5	15	14
SLNV-27-0254	28	35	21.5	15	15	30	76	22.5	20.5	5	3.5	6.35x25.4	5	15	14

⁹⁸⁾ Thread/remaining thread visible

drylin® Stop motion linear guides | Product Range

Telescopic rails with locking mechanism



Order key

Type	Size	Option
NT - LM - 35 - 300		
drylin® N	Telescopic system	Locking mechanism
	Rail width	Length [mm]

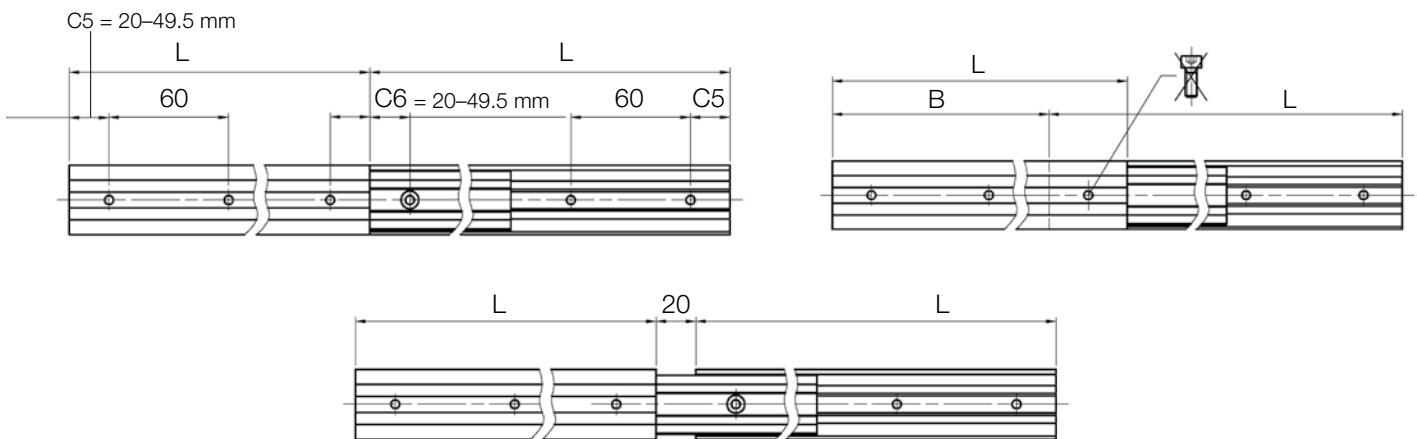
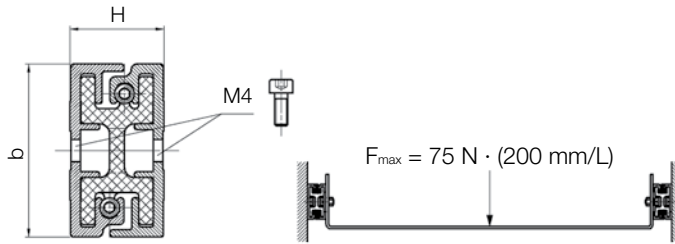

drylin® NT LM in adjustment of guard



drylin® NT LM in guard door adjustment in a machine tool

drylin® detent in end and center position at full extension
dimensions [mm]

Part No.	b	H	Lmin	Lmax.
NT-LM-35-...mm	35	19	140	600

Individual position detent upon request; The length divided by the locking distance must be an even number.
e.g. Length 250mm, latching in 62.5mm step: $250/62.5 = 4$



Order example:

NT-LM-35-300: drylin® N telescopic rail with locking mechanism, 35mm width, retracted length 300mm

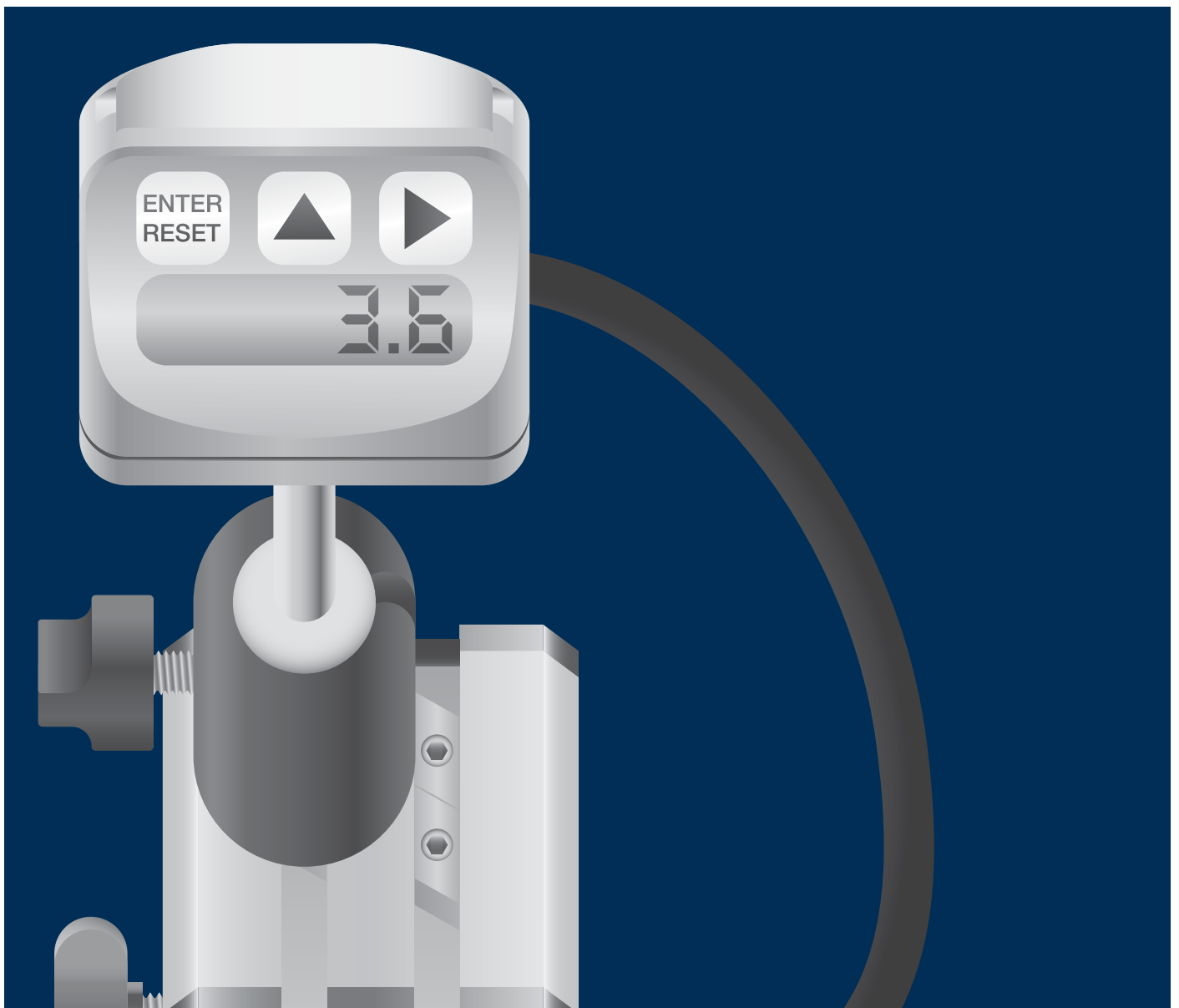

drylin® linear technology – Digital measuring systems

Ready-to-install complete systems

Sensor, measuring display, magnetic tape
included

Battery operated

Ideal for positional stops



drylin® Digital measuring systems | Advantages

Self-lubricating, light, quiet, long service life, low cost



Digital drylin® measuring systems

The drylin® measuring systems use magnetic tape with incremental measuring systems. The integrated battery ensures a service life of many years and enables almost absolute measurement. The sensor, measuring display and magnetic tape are integrated in self-lubricating drylin® W and Q linear guides. With customer-specific rail lengths, systems are supplied as ready-to-install linear modules. Typical application areas are format adjustments and mechanical stop adjustments.

- Simple installation
- Easy to adjust
- Self-lubricating and maintenance-free
- Battery powered
- Optional:
 - Mounted rail -> measuring carriage moves
 - Mounted measuring rail -> carriage moves

Typical application areas

- Format adjustments
- Bending machines
- Band and chop saws



From stock

Detailed information about delivery time online.



Price breaks online

No minimum order value. No minimum order quantity.



Max. +158°F (+70°C)

Min. +14°F (-10°C)



Carriage widths: 45 - 134mm

Rail length: up to 4,000mm

drylin® Digital measuring systems | Product overview

Profile guide systems for almost unlimited design freedom



drylin® Q for unsupported structures

- Carriage with integrated measuring sensor
- With fixed or flexible adjustable display
- Protected magnetic tape

► Page 1376



drylin® SLW with integrated measuring sensor

- Driven by lead screw system
- Programmable display
- Available with lock

► Page 1377



drylin® W with digital measuring display

- Max. rail length up to 4,000mm
- Measuring display attached to the side of the carriage
- Self-lubricating adjusting of the carriage

► Page 1378



drylin® W with fixed measuring display

- Max. rail length: up to 2,000mm
- Measuring display fixed in place
- Moving rail with stationary carriage

► Page 1378



drylin® W with external measuring display

- Carriage with integrated sensor
- Flexible positioning
- Including manual clamp

► Page 1379



drylin® W for external data output

- Variable sensor type, output power and cable length
- Cable guide and protection through igus® e-chain®
- 1 and 4 edge triggering

► Page 1380



Stop motion measuring system with rail scale

- Low-cost measuring system based on the drylin® N prism rail
- 4 preloaded carriage options
- Scale included on rail

► Page 1381

Measuring display for series SLWM/QKM



Properties	
Measuring principle	Incremental, with zero function
Display	LCD display 7.5mm high digits
Display accuracy	Max. 0.1mm
Display/display area	-99999 ... +99999
Function	Digit direction, decimal point, unit of measurement (mm, imperial), preset activation
Power supply	Battery 1/2 AA, 3.6 V integrated, service life of up to 4 years
Magnetic sensor	Securely connected (external)
Design	Installation housing
Housing	Plastic
Protection class	IP54 display IP67 sensor
Working temperature	+32°F to 122°F (0 to +50°C)
Humidity	35-85 %
Speed	Max. 2.5m/s
Display keyboard	3 function buttons

Measuring displays for series WKM2/WKMEDR



Properties	
Measuring principle	Incremental, with absolute value function
Display	Low power LCD with integrated sensor, quasi absolute, battery operated
Display accuracy	Max. 0.1mm
Repeatability	± 1 digit
Display/display area	-99999 ... +99999
Function	Freely programmable, e.g. parameter, resolution or offset
Resolution	0.01 0.05 0.1 1mm 0.001, 0.01 inch Freely programmable angled display
Keys	3 keys, membrane keypad
Power supply	Battery integrated, service life of up to 10 years
Magnetic sensor	Securely connected
Reading distance	≤ 1.5mm integrated sensor ≤ 2mm external Sensor
Design	Installation housing
Housing	Zinc die-casting
Protection class	IP20 overall device IP60 display page
Working temperature	+32°F to 140°F (0 to +60°C)
Humidity	≤ 95% rel. humidity, condensation not permissible
Speed	≤ 10m/s
EMC	EN61000-6-2 interference immunity / immission EN 61326-1 emitted interference / emission (class B)

Length measuring system WKMEX



Properties	
Measuring principle	Incremental
Repeatability	± 0.025mm
Measuring principle	Linear
Pole division	5mm
Sensor housing	Zinc die-casting
Protection class	IP67
Application temperature	+14°F to 158°F (-10 to +70°C)
Bearing temperature	-13°F to 185°F (-25 to +85°C)
Max. humidity	95%, non-condensing
Max. speed	4.0m/s
VDC power supply	5 VDC or 10... 30 VDC
Current draw	5 VDC: max. 200 mA
	10.. 30 VDC: max. 150 mA
Evaluation electronics	Sensor with integrated evaluation electronics and index impulse
Output power	5 V-TTL line driver or 10.. 30 V_HTL
Source tracks	A, A',B, B', Z, Z'
Max. cable length	Max. cable length 5V/5V-TTL: 10m
	10-30V/10-30V: 30m
	10-30V/5V-TTL: 50m
Max. permissible distance from magnetic tape	2.0mm
Connection method	Open cable ends

Magnetic tape for measuring display WKM



Properties	
Encoding	Incremental, single-track system
Basic pole division	5mm pole division
Band width	10mm
Operating temperature, processed	+32°F to 140°F (0 to +60°C)
Tape structure	Magnetic tape stuck on with adhesive tape
External magnetic influence	External magnetic fields on the magnetic tape surface must not exceed 64 mT (640 Oe; 52KA/m) as this can damage or destroy the magnetic tape encoding
Protection class	Carrier tape, stainless steel (optional)

drylin® Digital measuring systems | Product Range

Integrated measuring systems



- Protected magnetic tape
- Attachment options using slot nuts
- Manual clamp
- Profile AWMQ-20 max. length 1,500mm
- Sensor integrated in the carriage, saving space
- Technical data ► **Page 1374**



Order key

Type	Option	Size
Q	K	M - 01 - 20
Square	Measuring system	
	Metric	
	Carriage type	
	Installation size	

Options:

- 01: Display flexible with angle joint
02: Display fixed in place

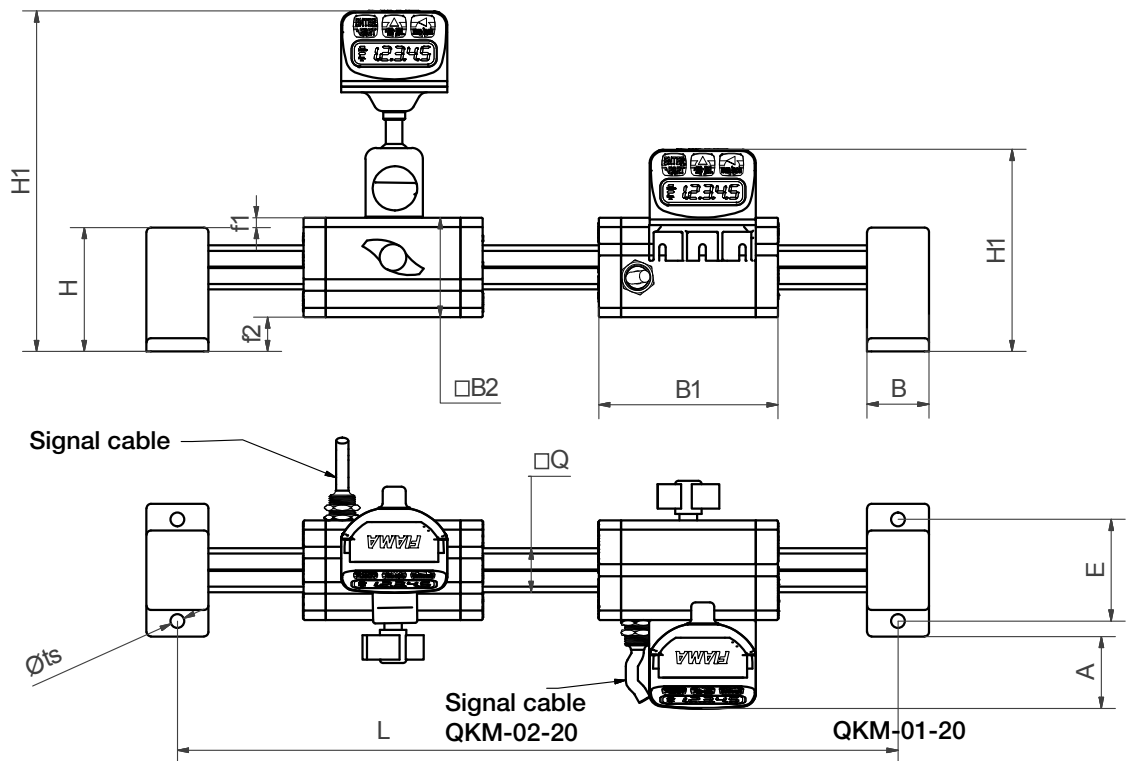

Dimensions [mm]

Part No.	M max. [Nm]	L Shaft end support + carriage + stroke	B h7	B1	B2	H	H1	E	Q	ts	f1	f2	A
QKM-01-20	10	28 + 94 + stroke	28	94	45	58	155	46	20	6.2	4.5	15.5	33
QKM-02-20	10	28 + 94 + stroke	28	94	45	58	92	46	20	6.2	4.5	15.5	33



Order key

Type

Size

S L W M - 1080

drylin® SLW
linear module

Measuring system

Installation size
SLW linear module

- Sensor integrated in the carriage, saving space
- Battery operated
- Integrated magnetic tape
- Extensive accessories available
- Technical data ► **Page 1374**
- Technical data drylin® linear module SLW
► **page 1584**

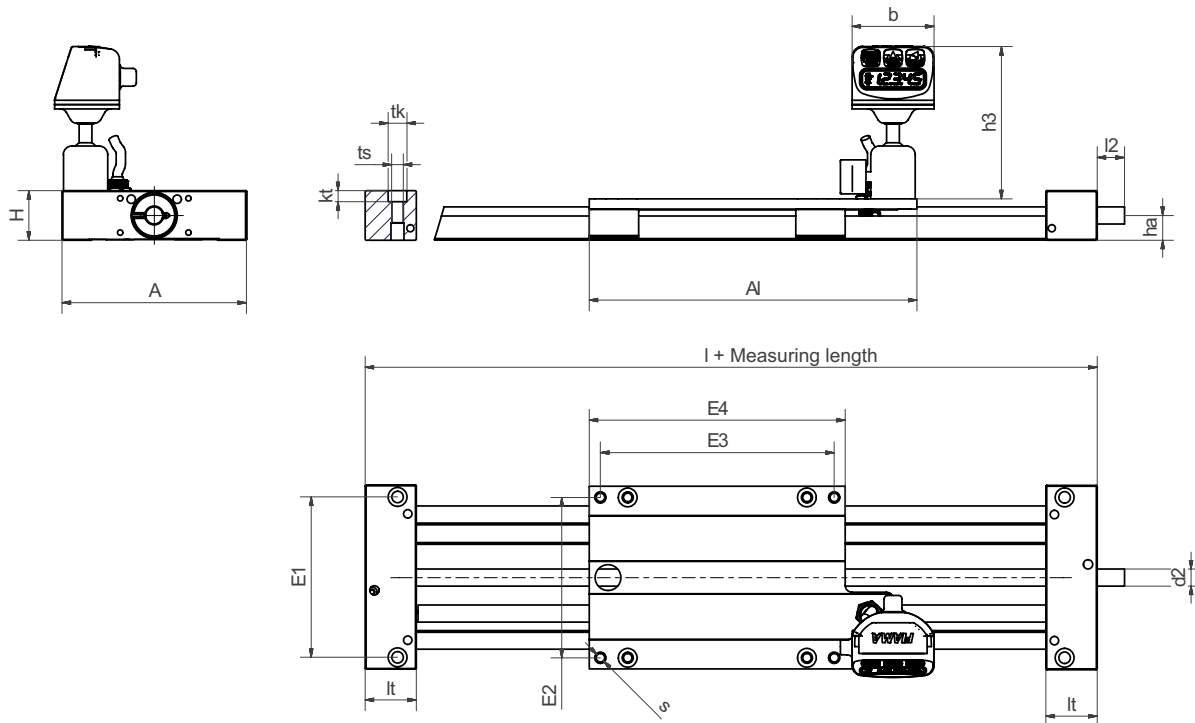

Dimensions [mm]

Part No.	A	Al	H	E1	E2	E3	E4	I	l2	lt	tk	kt	ts	s	ha	d2	h3	b
SLWM-1080	108	192	29	94	94	137	150	236	17	22	11	6.4	6.8	6.6	14.5	Tr10x2	90	50

WKM2, series 10 and 20



Order key



Type Design

WKM2 -10-80-15-01-R

drylin® W
measuring system

Installation size

Rail width

Carriage length

Number of carriages

Display right-mounted

- Lockable carriage
- Display optionally to the right (R) or left (L) of the guide carriage
- Max. rail length 4,000mm (effective measuring length max. 3,757mm)
- Technical data ► **Page 1375**

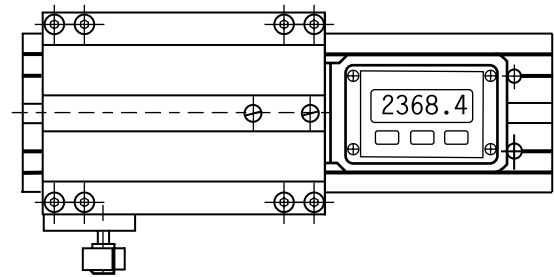
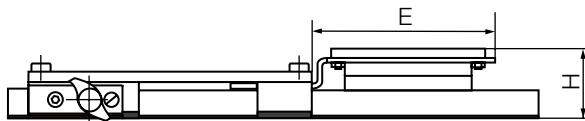

Dimensions [mm]

Part No.	drylin® rail profile sm	H	E
WKM2-10-80-15-01-L	WS-10-80	36	93
WKM2-10-80-15-01-R	WS-10-80	36	93
WKM2-20-80-15-01-L	WS-20-80	40	93
WKM2-20-80-15-01-R	WS-20-80	40	93

⁸⁹⁾ Profile dimensions ► **Page 1094**

WKM2, series 11

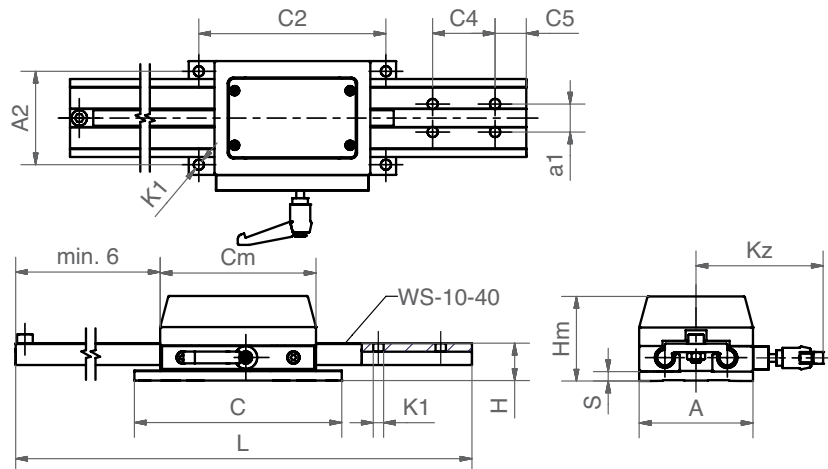

Dimensions [mm]

Part No.	L	C4	C5	a1	C2	A2	K1	C	A	H	S	Cm	Hm	kz
	Max.													
WKM2-11-40	2,000	40	20	18	120	60	6.6	133	73	24	6	100	54	82

Measuring system with flexible readout display

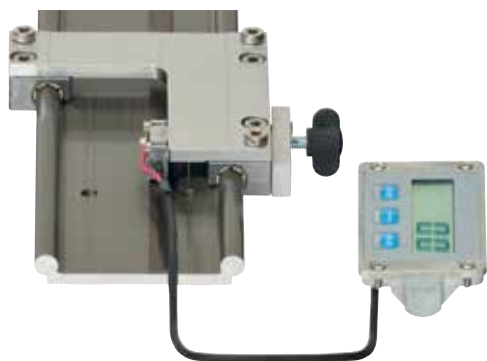

● Technical data ► Page 1374

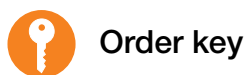

Order key

Type Size

WKMEDR - 10-80-10

drylin® W measuring system	External Display	Assembly right	Installation size	Rail width	Carriage length
----------------------------	------------------	----------------	-------------------	------------	-----------------

Options:

R: Assembly to the right of the guide carriage

L: Assembly to the left of the guide carriage

e-chain®
047.10.028.0.xxx
not included

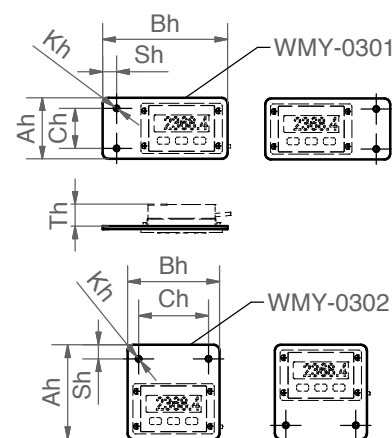
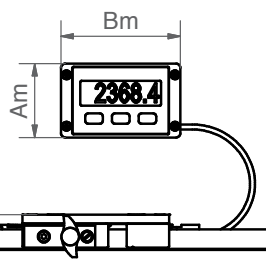
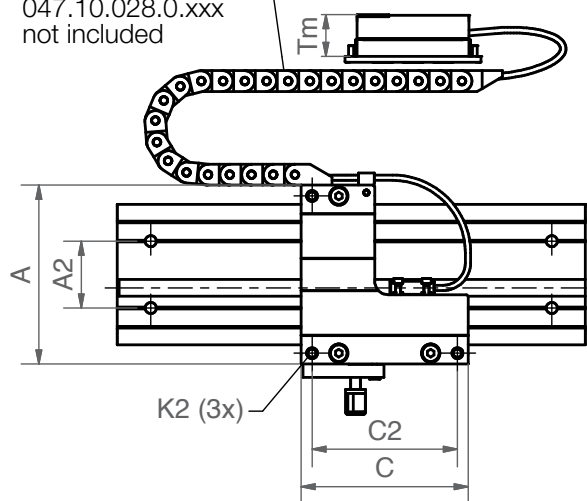

Assembly options of the external display

Dimensions [mm]

Part No.	A	C	A2	C2	K2	H2	Am	Bm	Tm
	Width	Length				±0.17			
WKMEDR(L) ⁹⁰ -10-80-10	107	100	94	87	M6	24	82	51	25

⁹⁰ Suitable for assembly on the right (R) or left (L)

Dimensions-Display incl. support [mm]

Part No.	Ah	Bh	Ch	Sh	Kh	Th
WMY-0301	61	125	40	14	∅5.4	22
WMY-0302	94.5	92	70	14	∅5.4	22

drylin® Digital measuring systems | Product Range

Ready-to-install system for external data output



- At 4 edge triggering (setting parameters of the display or control system, for example. IW4) and +20°C ambient temperature:
resolution: $\pm(0.025 + 0.02 \cdot L)$ L = measurement length in metres; repeatability: ± 0.025 mm
- At 1 edge triggering (setting parameters of the display or control system, for example. IW1) and +20°C ambient temperature:
resolution: $\pm(0.1 + 0.02 \cdot L)$ L = measurement length in metres; repeatability: ± 0.025 mm
- Small sensor with integrated evaluation electronics
- Output signals: Differential mode sustained short circuit-proof with inverted signals (A, A/, B, B/, Z, Z/)
- Technical data ► **Page 1375**

Order key

Type	Size/Design
WKM EX-10-80-10-2.5-00-01-1000	
drylin® W measuring system	External data output
Installation size (shaft Ø)	Rail width
Rail length 100mm	Rail length 100mm
Cable length [m]	Sensor version
Number of carriages	Rail length [mm]

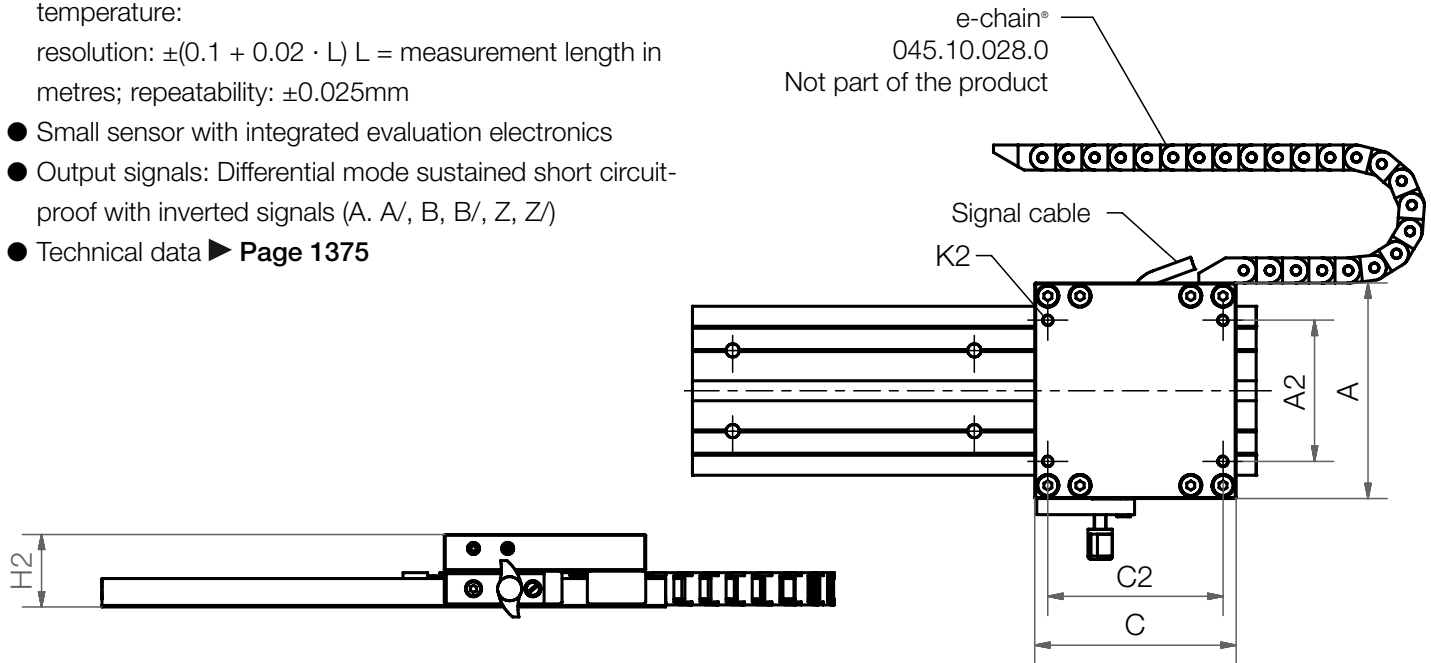

Dimensions [mm]

Part No.	H2	C	C2	A	A2	K2	Resolution
WKMEX-10-80	36	100	87	107	70	M6	0.1

Versions

Sensor version	Nominal voltage	Output power	Max. length of signal cable
00	10–30 V	HTL 10–30 V	30 m
01	10–30 V	TTL Line Driver	50 m
11	5 V	TTL Line Driver	10 m

To place an order, please add the sensor type to the part number. Order example: WKMEX-10-80-00

Stop motion measuring systems with rail scale



Order key

Type	Size
NKV - 27 - MES - 1000	
drylin® pre-load prism slide	Installation size
Measuring system	Measuring length

- Low-cost measuring system based on drylin® pre-load prism slide
- Carriages with individually adjustable pre-load in 4 different strengths
- Including scaling on the rail
- Cost-effective, durable, practical
- Guaranteed holding force from 1.3N to 11.7N
- Due to stop motion preload, the measuring system is suitable for vertical installation without any further clamping

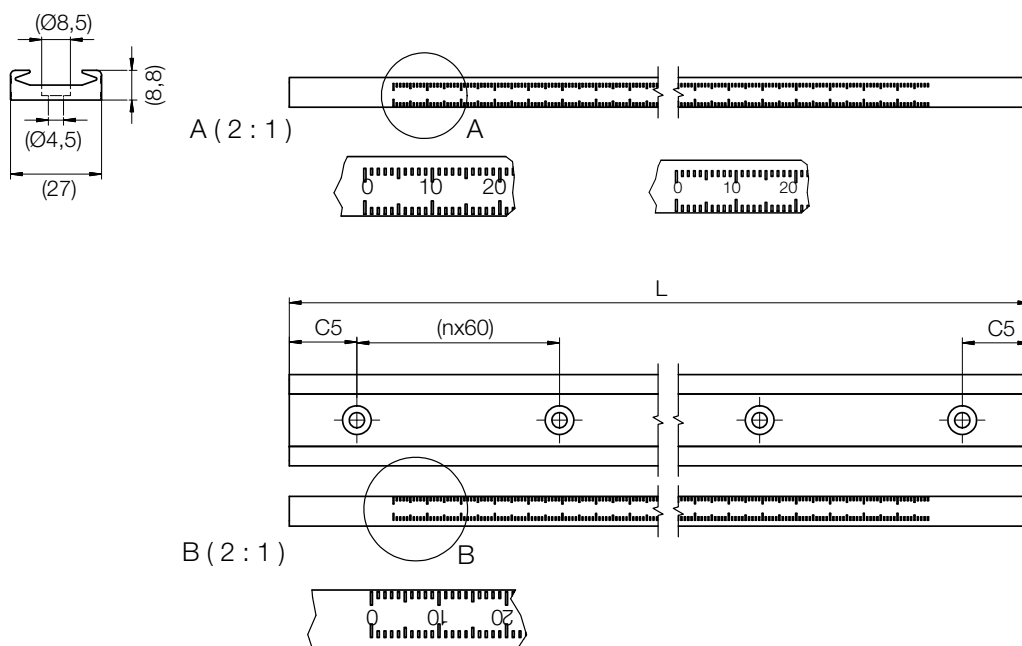

Dimensions [mm]

Part No.	A	AI	H	E1	E2	E3	I*
	±0.2	-0.1	±0.2	±0.15	±0.15	±0.15	
NKV-27-MES-1000	27	35/60	22	15	18	30	35/53/60/78
NKV-27-MES-2000	27	35/60	22	15	18	30	35/53/60/78

Part No.	hw	lt	lb	ts	tg	Average displacement force [N]	K1
	±0.25	±0.2					
NKV-27-MES-1000	22.5	20.5	5.5	3.5	M3	2-15	4.5
NKV-27-MES-2000	22.5	20.5	5.5	3.5	M3	2-15	4.5

Notes

A large grid of graph paper for taking notes, consisting of 20 columns and 30 rows of small squares.

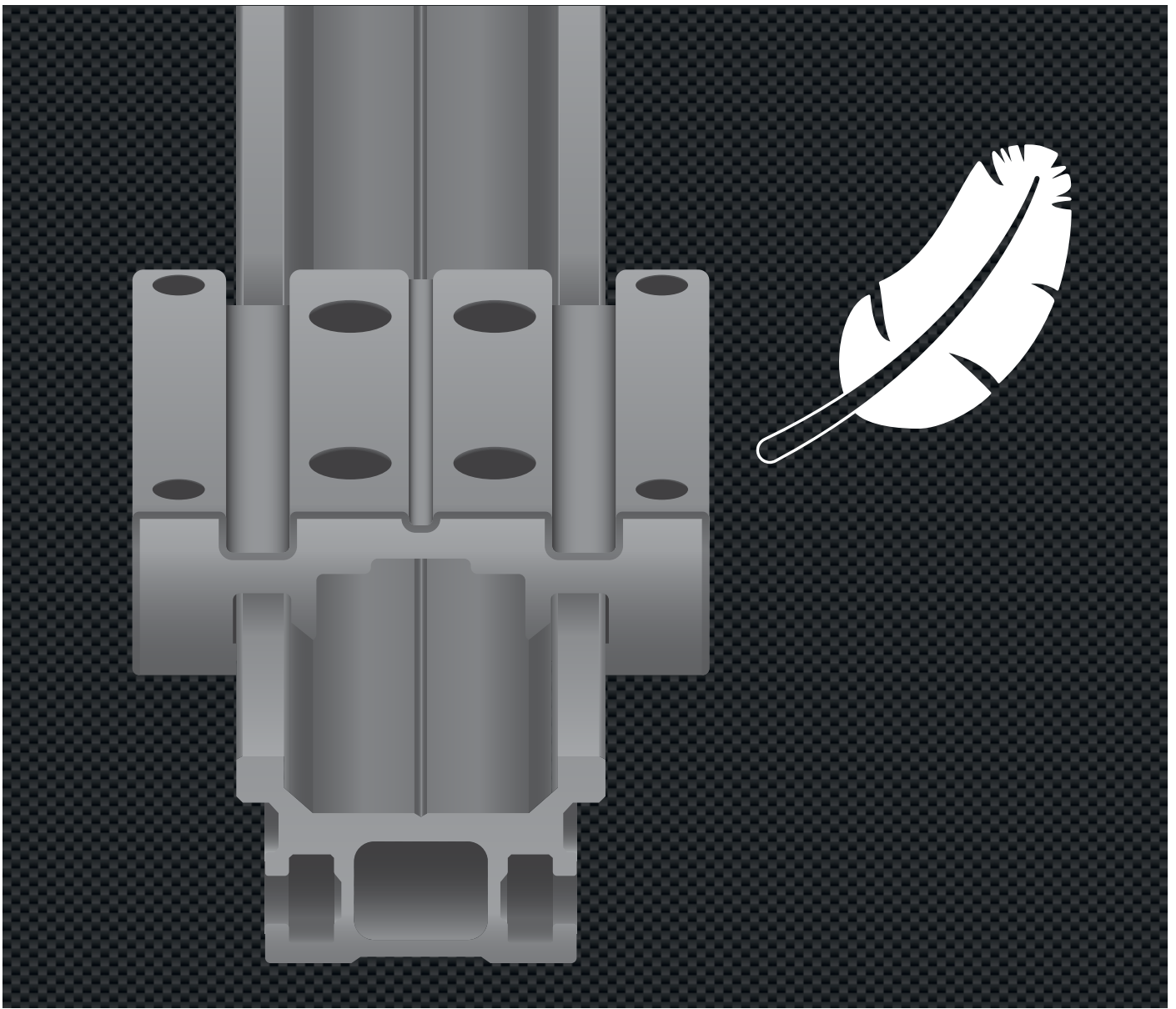

drylin® linear technology – Carbon fiber

Lightweight and durable

Non-metallic

Non-magnetic

X-ray transparent

Self-lubricating and maintenance-free



drylin® carbon fiber | Advantages

Extremely lightweight and 100% self-lubricating

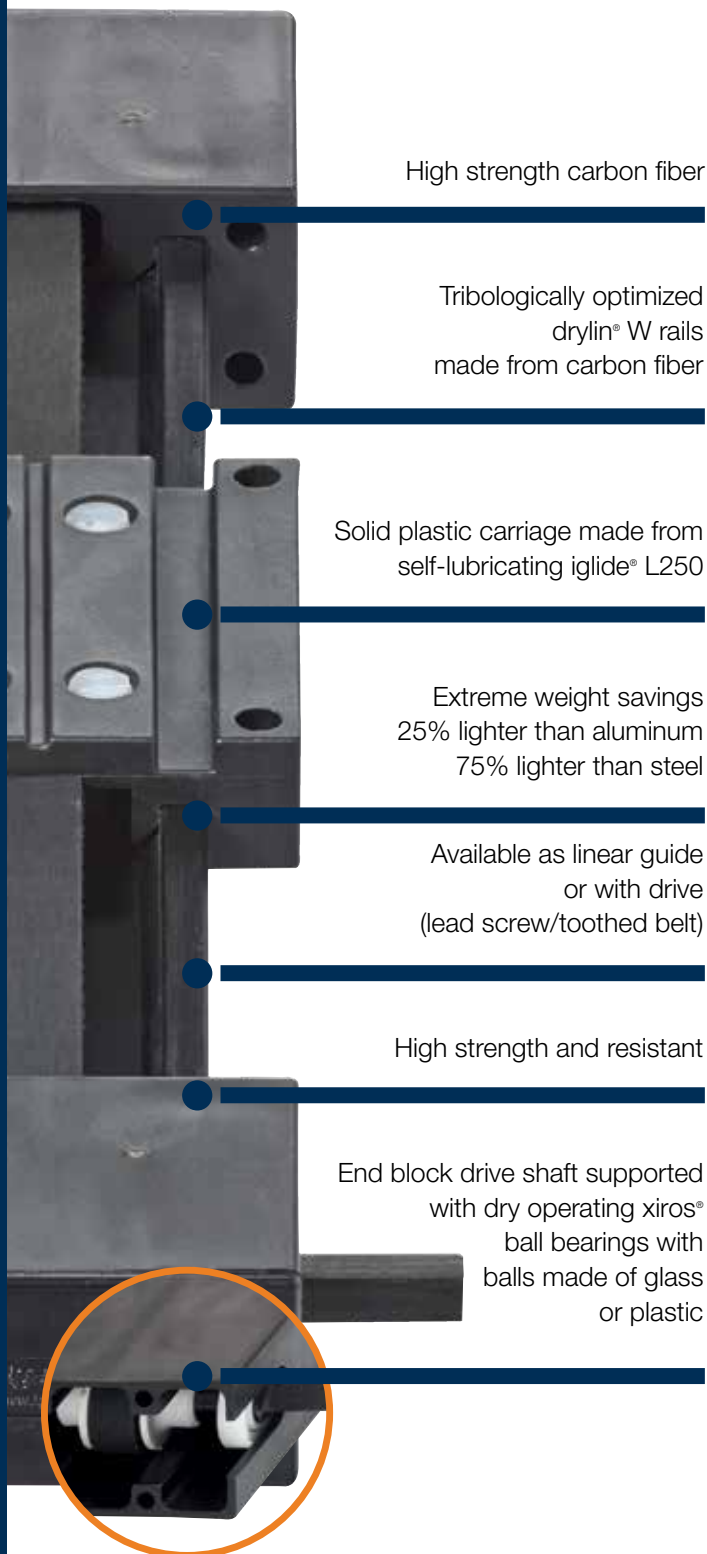

High strength carbon fiber

Tribologically optimized drylin® W rails made from carbon fiber

Solid plastic carriage made from self-lubricating iglide® L250

Extreme weight savings
25% lighter than aluminum
75% lighter than steel

Available as linear guide or with drive (lead screw/toothed belt)

High strength and resistant

End block drive shaft supported with dry operating xiros® ball bearings with balls made of glass or plastic

Extremely lightweight: drylin® carbon fiber

Extremely lightweight and strong – tribologically optimized drylin® linear guides and actuators made from plastic plain bearings and carbon fiber guide rails. All systems are 100% lubrication and maintenance-free.

- Extremely lightweight
- Wear-resistant
- Tough and reliable
- Non-metallic / non-magnetic
- X-ray transparent

Typical application areas

- Aircraft interior
- Laboratory and medical technology
- Measuring technology



Delivery time

Detailed information about delivery time online.



Price breaks online

No minimum order value. No minimum order quantity.



Max. +140°F (+60°C)

Min. +32°F (0°C)

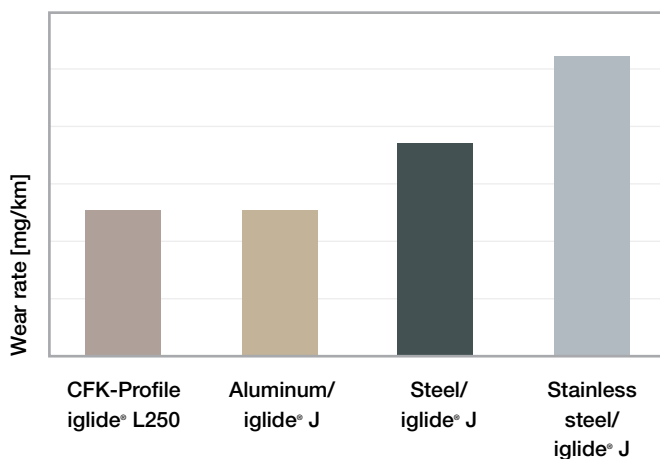

drylin® carbon fiber | Product overview

Linear guides and actuators made of solid plastic and carbon fiber

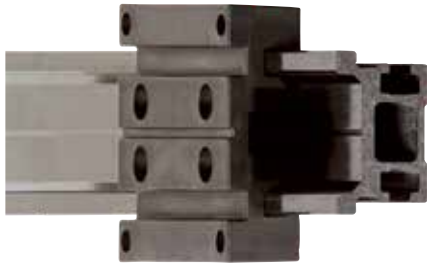

Carbon-fiber drylin® W liner guide

- Extremely lightweight and strong carbon profile
- Tribologically optimized
- Solid plastic carriage made from iglide® L250

► Page 1386



drylin® ZLW belt-driven actuator with carbon-fiber guide rail

- Non-metallic
- Neoprene toothed belt drive with glass fiber reinforcement
- Max. stroke length 1,000mm

► Page 1387



drylin® SAW linear actuator made from carbon fiber

- drylin® W profile made of carbon fiber
- Drive: Trapezoidal or high-helix lead screw
- Available with aluminum lead screw

► Page 1388



drylin® SHTP linear actuator with round carbon fiber shafts

- Very lightweight due to carbon fiber hollow shafts and solid plastic
- Left/right self-centering options
- Configurable with accessories for manual operation
- Aluminum lead screw available

► Page 1389



drylin® CWM round shaft made from carbon fiber

- Very lightweight due to hollow shaft geometry
- Hollow rail for supply lines
- Surface UCU (unidirectional/cross-winding/unidirectional)

► Page 1390

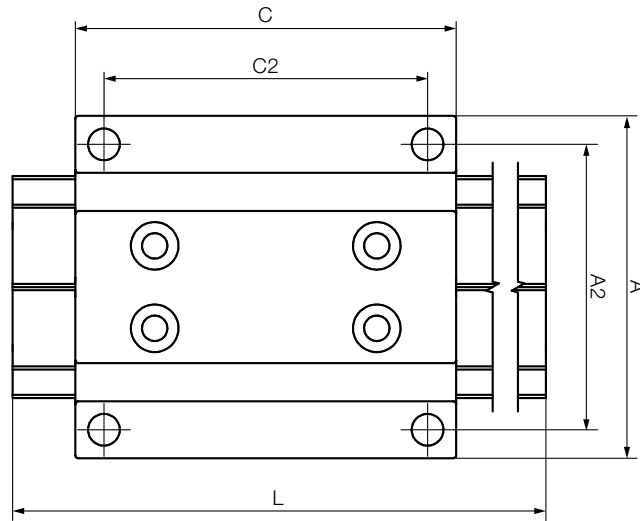
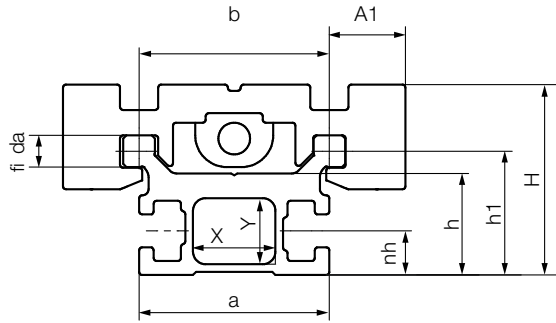

Order key
Complete solution

Type				Dimensions		
W K P C -06-30-06						
drylin® W	Complete system	Plastic	Carbon fiber	Shaft Ø	Rail width	Carriage length

Technical data – guide rail

Part No.	F max. radial		Weight	I _y	I _z
	stat.	dyn.			
	[N]	[N]			
WSPC-06-30	300	60	410	30,391	11,674

Dimensions [mm] – guide profile

Part No.	a	b	da	h	h1	nh	X	Y	L
WSPC-06-30	30	30	5 -0.1	16	19.5	7	13	10	3,000

Dimensions [mm] – guide carriage

Part No.	H	A1	A	A2	C	C2
WWPL-06-30-06	30	12	54	45	60	51

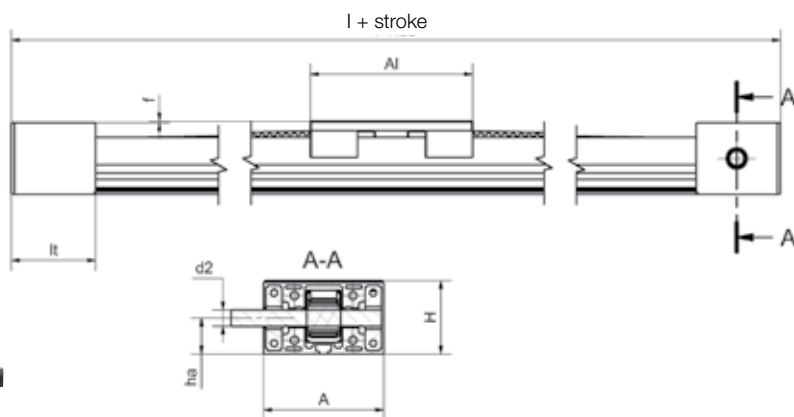

Order key

Type Dimensions / Type

ZLW-0630-P-1000

Toothed belt axis

Shaft Ø

Rail width

Plastic

Stroke length

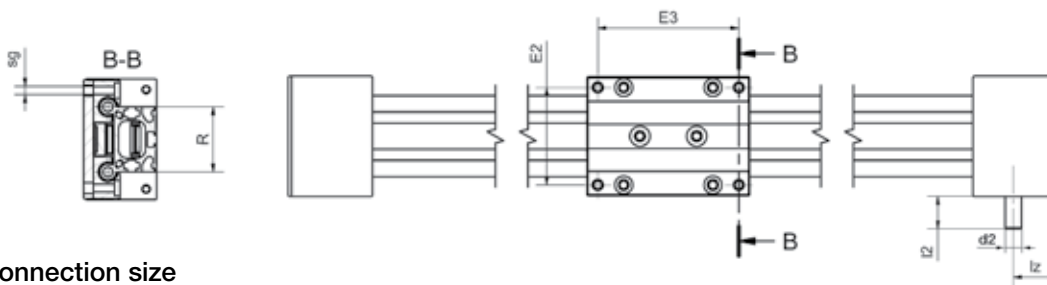

Connection size

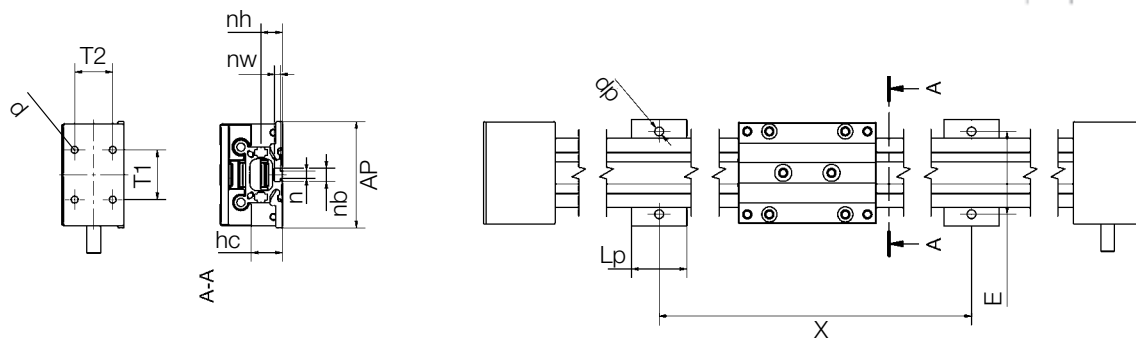

Technical data

Part No.	Weight without stroke [kg]	Weight 100mm stroke [kg]	Max. stroke length [mm]	Transmission Linear travel per revolution [mm/rev]	Tooth profile	-material	Drive belt -width [mm]	-tension [N]
Basic 02 P	0.3	0.08	1,000	54	HTD 3M	Neoprene with GF	9	25

Dimensions [mm]

Part No.	A	Al	H	E2	E3	l	R	f	lt	ha	lz	l2	d2
	-0.3			±0.15	±0.15		±0.15		-0.3				h9
ZLW-0630-P	54	60	31	45	51	144	30	3	42	14	20	20	8

Connection size

Part No.	X	E	AP	Lp	dp	d	T1	T2
		±0.2	-1.0				±0.25	-0.3
ZLW-0630-P	variable	40	52	15	5.5	3	20	21



Order key
Complete solution

Type Dimensions / Type

SAW-06 30-P-1000

drylin® linear actuator	Shaft Ø	Rail width	Plastic	Stroke length
-------------------------	---------	------------	---------	---------------

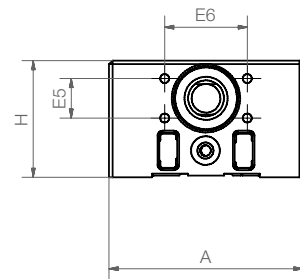
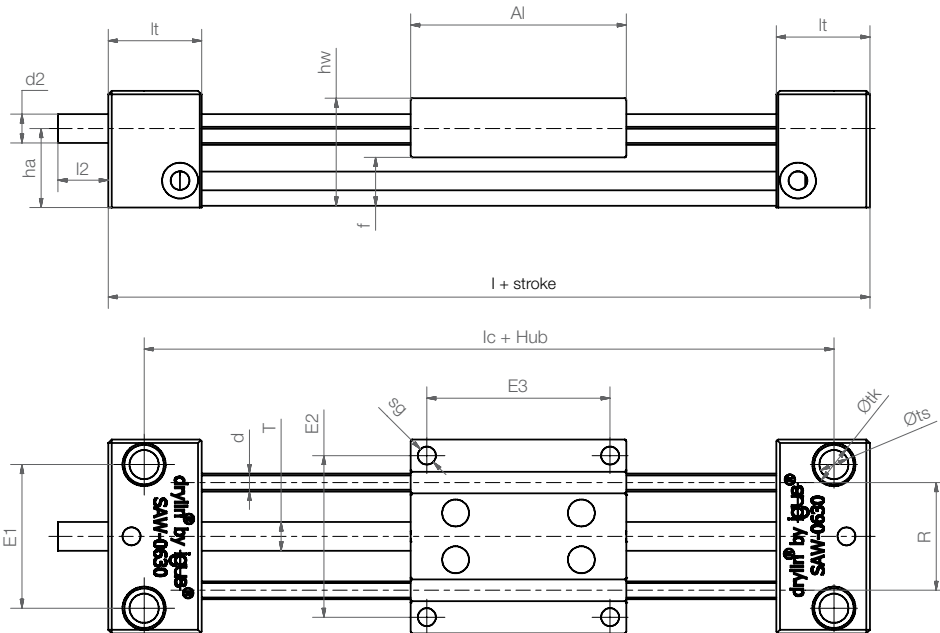

Technical data

Part No.	Stroke length [mm]	Weight		max. speed [1/min]	Max. static load capacity	
		Standard [kg]	Additional per 100mm [kg]		axial [N]	radial [N]
SAW-0630-P-...	300	0.25	0.07	1,000	50	50

Dimensions [mm]

Part No.	A	Al	H	E1	E2	E3	E5	E6	l	lc	hw	f	lt
	-0.3			±0.15	±0.15	±0.15							±0.1
SAW-0630-P-...	54	60	32.5	40	45	51	11	23	112	92	80	13.5	26

Part No.	tk	ts	sg	d	T	l2	d2	ha
				ø				
SAW-0630-P-...	11	6.6	5	□ 5	8	15	Tr8x1.5	22

drylin® carbon fiber | Product Range

Linear actuator with carbon fiber hollow shafts

drylin®
carbon
fiber



Order key
Complete solution

Type

Dimensions / Type

HTSP-01-12-CWM

Linear actuator

Plastic

Design

Dimension

Carbon fiber shaft

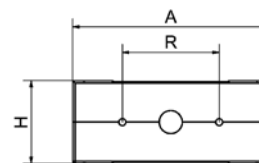
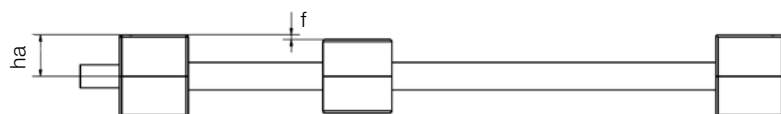
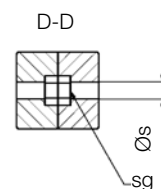
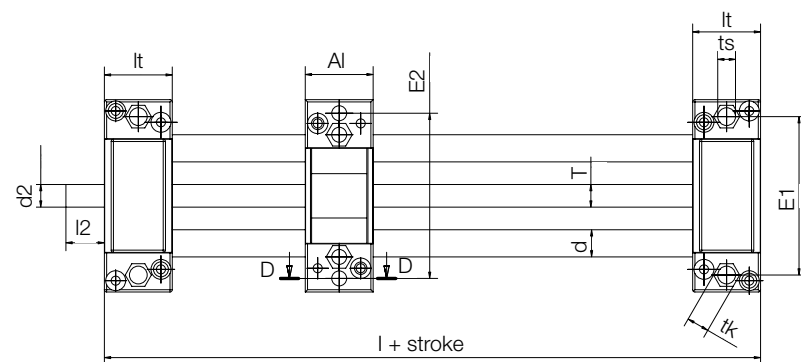

Technical data

Part No.	Max. stroke length [mm]	Carbon fiber shaft		More information
		Weight [kg]	Additional [kg] (per 100mm)	
SHTP-01-12-CWM	500	0.3	0.06	Drive nut and linear bearings made from iglide® J
SHTP-02-12-CWM	500	0.3	0.06	Bearing and nut integrated into the carriage

Dimensions [mm]

Part No.	A	AI	H	E1	E2	l	R	f	lt	tk	ts
SHTP-01-12-CWM	85	30	36	70	73	90	42	2	30	10	6.0
SHTP-02-12-CWM	85	30	36	70	73	90	42	2	30	10	6.0
Part No.	s	sg	d	T	l2	d2 ⁹⁹⁾	ha	Max. static load capacity			
								axial [N]	radial [N]		
SHTP-01-12-CWM	6.3	M6	12	Tr10x2	17	Tr10x2	18	100	100		
SHTP-02-12-CWM	6.3	M6	12	Tr10x2	17	Tr10x2	18	100	100		

⁹⁹⁾ Lead screw end unmachined (standard)



Order key

Type

Dimensions

CWM-12-300

Carbon fiber shaft

Metric

Outer Ø

Shaft length

- Material: CFK composite
- Roundness tolerance: $\pm 0.05\text{mm}$
- Diameter tolerance: -0.1mm
- Application temperature: max. $+176^\circ\text{F}$

Dimensions [mm]

Part No.	Design	Diameter -0.1	Max. length [mm]	Weight [g]
CWM-12	Hollow shaft	12/9	2,000	70
CWM-16	Hollow shaft	16/12.5	2,000	120
CWM-20	Hollow shaft	20/16	2,000	170
CWM-30	Hollow shaft	30/26	2,000	270

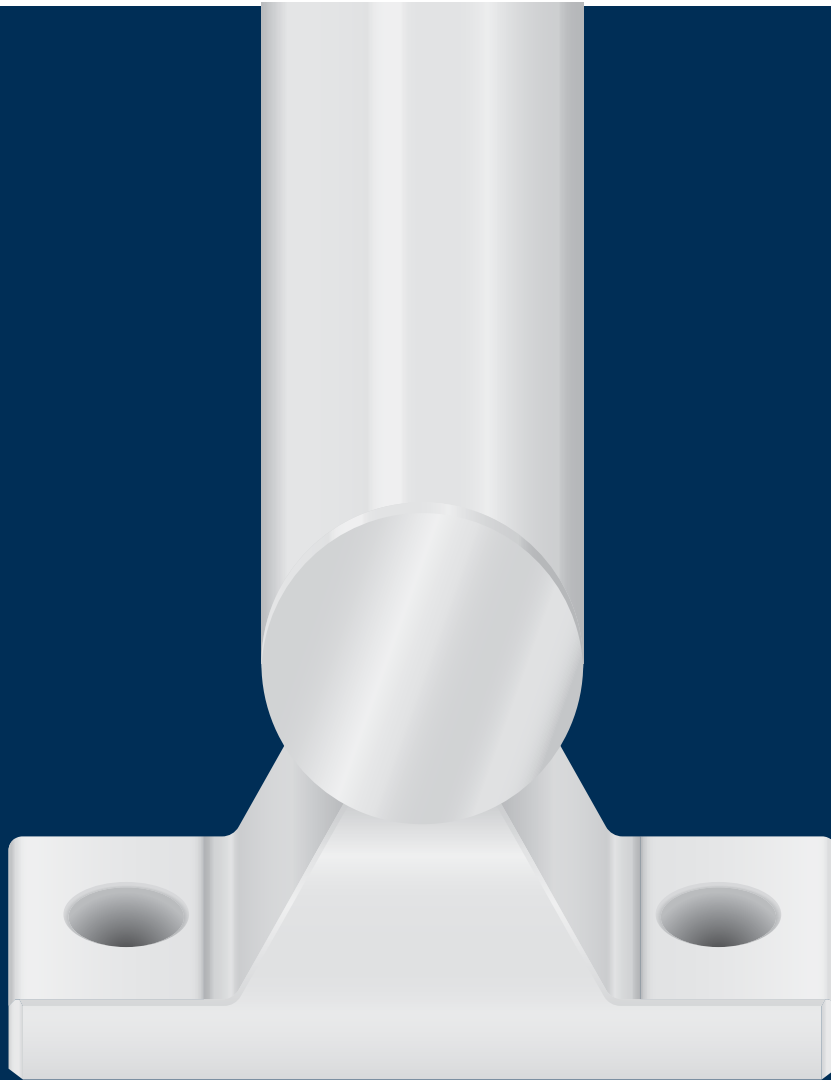

drylin® linear technology – products made of stainless steel

Temperature resistant up to +482°F

Corrosion-free

Chemical resistance

Ready-to-install linear guides and modules

Self-lubricating and maintenance-free



drylin® stainless steel | Advantages

Machine parts made of stainless steel are designed to survive in the worst environments. Heat, pressure, seawater, liquid and gaseous media like detergents and other chemicals. If these machine parts also have to work as a bearing, the combination with iglide® high-performance polymers is ideal. All bearings are self-lubricating and the plastic parts are secured axially and radially in the housings with positive fit.



The use of AISI 316Ti and AISI 304 makes the guides resistant to seawater and chemical contact corrosion, and the guide shafts are also made from AISI 316Ti. Despite the lack of surface hardness, required for instance by recirculating ball bearings, they are suitable for use with plain bearings. The large contact surface of a plain bearing diminishes the surface pressure to a safe value.



Lubrication freedom with drylin® for a baking and conveyor unit

The suitable iglide® material can be selected according to the application and used for linear and/or rotary movements.

- Self-lubricating
- Temperature resistant up to +482°F
- Corrosion-free
- Chemical resistance
- Cost-effective

Typical application areas

- Food and bottling industry
- Meat processing
- Harbor and crane facilities
- Yacht building
- Chemical industry
- Electroplating industry
- Medical- and rehabilitation technologies
- Packaging industry



drylin® W guide rails are accredited to cleanroom-standards and therefore used in this blister machine

drylin® R linear plain bearings | Product Range

Closed, 303 stainless steel adapter (1.4305), Self-aligning - iglide® J liner

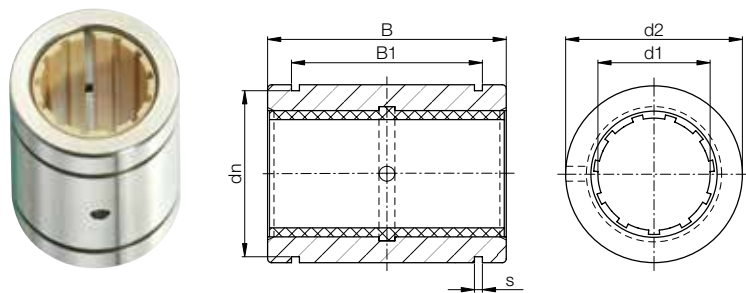

Order key

Type	Size	Size
R J U I - 01 - 12 - ESR		
Closed	iglide® J	Liner
	Inch	Standard
	Diameter	Stainless steel

- Suitable shafting for iglide® J: DryLin® AWI aluminum, SWI/SWI2 hardened steel, 300 series stainless Best shafting for X: hard-chrome and hard-stainless steel
- Secured by snap ring
- Dimensionally interchangeable with linear ball bearings



⁷⁸⁾ According to igus® testing method ► Page 1210

⁸²⁾ Design tips ► Page 1209

Please note: Installation instructions ► Page 1212

Dimensions (inch)

Part No.	Nominal Size d1	Tolerance ⁷⁸⁾	d2 ISO h7	B ISO h10	B1 ISO H10	s	dn
RJUI-01-08ESR	1/2	.0016 - .0032	.8750	1.2500	.979	.0520	.8200
RJUI-01-10ESR	5/8	.0016 - .0032	1.1250	1.5000	1.124	.0620	1.0600
RJUI-01-12ESR	3/4	.0016 - .0032	1.2500	1.6200	1.186	.0620	1.1770
RJUI-01-16ESR	1	.0016 - .0032	1.5625	2.2500	1.773	.0740	1.4710
RJUI-01-20ESR	1-1/4	.0020 - .0041	2.0000	2.6200	2.023	.0740	1.8890
RJUI-01-24ESR	1-1/2	.0020 - .0041	2.3750	3.0000	2.440	.0950	2.2410

Housing Bore Recommendations

Nominal ID Size	Min.	Max.
1/2	0.8750	0.8758
5/8	1.1250	1.1258
3/4	1.2500	1.2510
1	1.5625	1.5635
1-1/4	2.0000	2.0010
1-1/2	2.3750	2.3760

Technical Data

Part No.	F max, dynamic ⁸²⁾ p = 725 psi (lbs)	F max, static ⁸²⁾ p = 5075 psi (lbs)
RJUI-01-08ESR	225	1575
RJUI-01-10ESR	338	2365
RJUI-01-12ESR	439	3077
RJUI-01-16ESR	811	5678
RJUI-01-20ESR	1184	8287
RJUI-01-24ESR	1622	11358

Available with drylin® liners



J200



E7



X

- X liner optional for chemicals/high temps up to 482°F for steel housing, up to 356°F for aluminum

drylin® W profile guides | Product Range

Closed, 303 stainless steel adapter (1.4305), Self-aligning - iglide® J liner

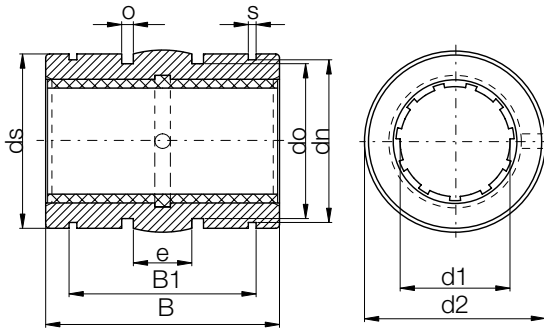

Order key

Type	Size	Size
R J U I - 03 - 12 - ESR		
Closed	iglide® J	Liner
		Inch
		Self-aligning
	Diameter	Stainless steel

- Suitable shafting for iglide® J: DryLin® AWI aluminum, case-hardened, 300 series stainless Best shafting for X: hard-chrome and hard-stainless steel
- Dimensionally interchangeable with linear ball bearings
- O-rings included with the self-aligning adapter



⁷⁸⁾ According to igus® testing method ▶ Page 1210
⁸²⁾ Design tips ▶ Page 1209
 Please note: Installation instructions ▶ Page 1212

Dimensions (inch)

Part No.	Nominal Size	Tolerance**	d2 ISO h8	B ISO h10	B1 ISO H10	s	ds	dn ISO h10	do	o -0.004	e
RJUI-03-08ESR	1/2	.0016-.0032	.8673	1.2461	.9870	.0520	.8556	.8200	.7120	.1250	.2815
RJUI-03-10ESR	5/8	.0016-.0032	1.1173	1.4961	1.1360	.0620	1.1055	1.0600	.9620	.1250	.3125
RJUI-03-12ESR	3/4	.0016-.0032	1.2421	1.6173	1.1980	.0620	1.2300	1.1770	1.0870	.1250	.3125
RJUI-03-16ESR	1	.0016-.0032	1.5547	2.2421	1.7890	.0740	1.5271	1.4710	1.3990	.1250	.5000
RJUI-03-20ESR	1-1/4	.0020-.0041	1.9881	2.6173	2.0390	.0740	1.9606	1.8890	1.8370	.1250	.6250
RJUI-03-24ESR	1-1/2	.0020-.0041	2.3634	2.9921	2.4630	.0950	2.3358	2.2410	2.1520	.1620	.7500

Housing Bore Recommendations

Nominal ID Size	Min.	Max.
1/2	0.8750	0.8758
5/8	1.1250	1.1258
3/4	1.2500	1.2510
1	1.5625	1.5635
1-1/4	2.0000	2.0010
1-1/2	2.3750	2.3760

Technical Data

Part No.	F max, dynamic ⁸²⁾ p = 725 psi (lbs)	F max, static ⁸²⁾ p = 5075 psi (lbs)
RJUI-03-08ESR	225	1575
RJUI-03-10ESR	338	2365
RJUI-03-12ESR	439	3077
RJUI-03-16ESR	811	5678
RJUI-03-20ESR	1184	8287
RJUI-03-24ESR	1622	11358

Available with drylin® liners



J200



E7



X

- X liner optional for chemicals/high temps up to 482°F for steel housing, up to 356°F for aluminum

drylin® W profile guides | Product Range

Closed, 303 stainless steel adapter (1.4305) - iglide® J liner

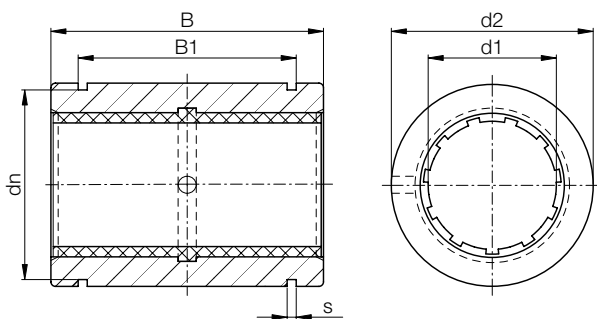

Order key

Type	Size	Option
R	J	U M -01 -12 - ES
Closed	iglide® J	Liner
		Metric
		Standard
		Diameter
		Stainless steel

- Dimensionally interchangeable with linear ball bearings
- Secured by snap ring



⁷⁸⁾ According to igus® testing method ▶ Page 1210

⁸¹⁾ Ø < 10 mm use iglide® JSM sleeve bearings

⁸²⁾ Design standards ▶ Page 1209

Please note: Installation instructions ▶ Page 1212

Dimensions [mm]

Part No.	d1	d1-Tolerance ⁷⁸⁾	d2	B	B1	s	dn
			h7	h10	H10	H10	h10
RJUM-01-12-ES	12	+0.030 +0.088	22	32	22.6	1.30	20.5
RJUM-01-16-ES	16	+0.030 +0.088	26	36	24.6	1.30	24.2
RJUM-01-20-ES	20	+0.030 +0.091	32	45	31.2	1.60	29.6
RJUM-01-25-ES	25	+0.030 +0.091	40	58	43.7	1.85	36.5
RJUM-01-30-ES	30	+0.040 +0.110	47	68	51.7	1.85	43.5

Technical Data

Part No.	F max, dynamic ⁸¹⁾ p = 5 MPa (N)	F max, static ⁸²⁾ p = 35 MPa (N)	Weight [g]
RJUM-01-12-ES	960	6,720	60
RJUM-01-16-ES	1,440	10,080	84
RJUM-01-20-ES	2,250	15,750	147
RJUM-01-25-ES	3,625	25,375	324
RJUM-01-30-ES	5,100	35,700	486

J200 - for Aluminum shafting

A180 - FDA compliant

X - High temperature and chemical resistance

E7 - for steel and stainless steel shafting

Available with drylin® liners



J200



E7



X

- X liner optional for chemicals/high temps
up to 482°F for steel housing,
up to 356°F for aluminum

drylin® W profile guides | Product Range

Single rails round, made of 316 stainless steel

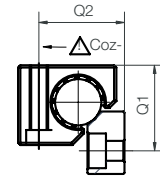
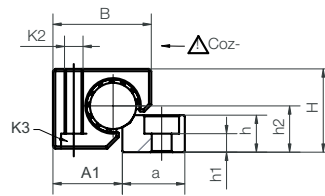
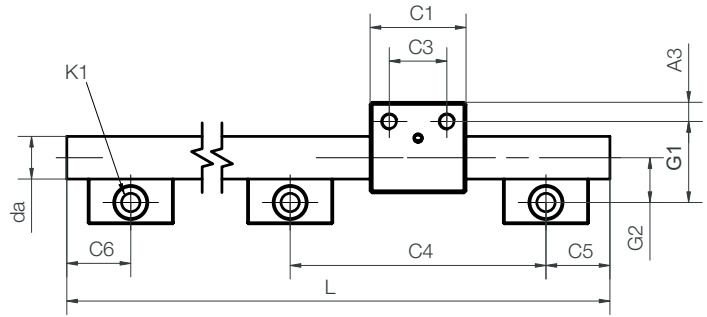

This assembled position is not possible for WS-10



Housing and shaft support material **AISI 316**
 Shaft material **AISI 316Ti**
 Installation size **25**
 Shaft, shaft support and housing material **AISI 316Ti**

Technical data and dimensions [mm]

Part No.	Weight [kg/m]	H ⁵⁷ ±0.25	da -0.1	L Max.	a -0.3	h	h1	h2	G1	G2	A1	Q1	Q2
WS-10-ES-FG	0.87	18	10	3,000	27	5.5	5.5 ⁵⁸	9	27	17	16.5	-	-
WS-16-ES-FG	2.22	27	16	3,000	27	12.0	4.5	14	33	19	25	32	28
WS-20-ES-FG	3.37	36	20	3,000	27	16.0	8.0	20	38	21	30	37	37
WS-25-ES-FG	5.21	45	25	3,000	32	20.0	9.0	25	46.5	25.5	37.5	45.5	46

Part No.	C1	C3	C4	C5 Min.	C5 Max.	C6 Min.	C6 Max.	A3	K1 for screw DIN 912	Geometrical moment of inertia		Moment of resistance	
										ly [mm ⁴]	lz [mm ⁴]	Wby [mm ³]	Wbz [mm ³]
WS-10-ES-FG	29	16	120	20	79.5	20	79.5	6.5	M6 ⁵⁸	491	491	98	98
WS-16-ES-FG	36	18	120	20	79.5	20	79.5	9.0	M8	3,217	3,217	402	402
WS-20-ES-FG	45	27	120	20	79.5	20	79.5	9.0	M8	7,854	7,854	785	785
WS-25-ES-FG	58	36	150	25	99.5	25	99.5	11.0	M10	19,175	19,175	1,534	1,534

⁵⁷ Height dimension minus the bearing clearance tolerance

⁵⁸ Through-holes

Can be combined with:



Suitable liner material:



drylin® W profile guides | Product Range

Pillow blocks, round, made from 316 stainless steel

drylin®
stainless
steel



Order key

Type	Design
drylin® W	WJUM-01-10-ES-FG
Liner material iglide® J200	
Pillow block, round	
Standard	
Size	
Precision casting	

Material:
ES-FG: Stainless steel
precision
casting

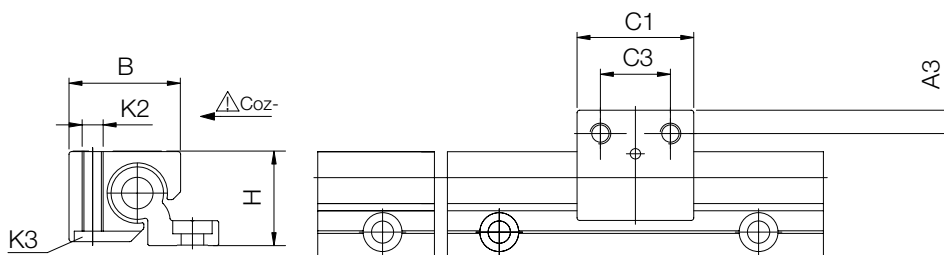

Note: H dimension can be found with rail/shafting selections

Technical data and dimensions [mm]

Part No.	Floating bearing clearance	Weight [g]	B	C1	C3	A3	K2	K3	Static load capacity		
									for countersunk head screw	Coy [N]	Coz+ [N]
WJUM-01-10-ES-FG ⁵⁹	–	57	26.0	29	16	6.5	M6	M5	3,800	3,800	950
WJUM-01-16-ES-FG ⁵⁹	–	134	34.5	36	18	9.0	M8	M6	6,900	6,900	1,450
WJUM-01-20-ES-FG ⁵⁹	–	280	42.5	45	27	9.0	M8	M6	11,000	11,000	1,900
WJUM-01-25-ES-FG ⁵⁹	–	564	52.5	58	36	11.0	M10	M8	16,000	16,000	3,600

⁵⁹ Alternative with XUMO-01-... liners for high temperatures available. Part No.: WXUM-01-...



X

- X liner optional for chemicals/high temps up to 482°F for steel housing, up to 356°F for aluminum

drylin® W hybrid roller bearings | Product Range

Hybrid roller bearing made from stainless steel

WJRM-01 with single roller

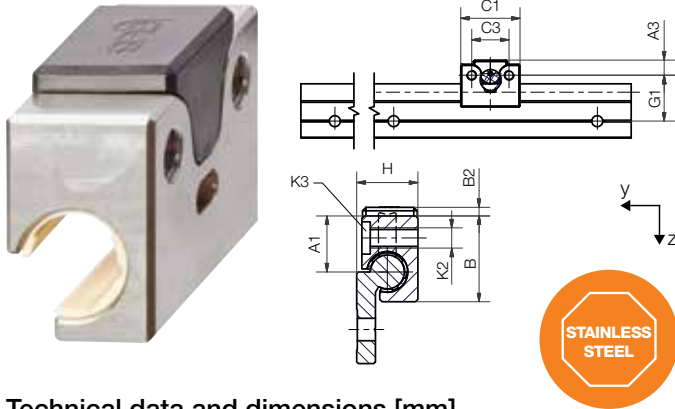

Order key

Type	Size	Material
WJRM-01-10 - ES		
Hybrid roller bearing	Single roller bearing	Size 10
		Stainless steel
Material ES: Stainless steel (AISI 316Ti) ES-FG: Stainless steel precision casting AISI 316 AL: Aluminum		

Technical data and dimensions [mm]

Part No.	Static load capacity Co [N]	Dyn. load capacity Cz+ at total running distance [km]			F · v Max. [N · m/s]
		10	100	200	
WJRM-01-10-ES-FG	250	250	90	50	50
WJRM-01-10-AL	250	250	90	50	50

Part No.	coefficient of friction in		Weight [g]	A1	A3	B	B2	C1	C3	G1	H	K2	K3 for screw
	z-direction [μ]	y-direction [μ]											
WJRM-01-10-ES-FG	< 0.1	-	57	16.5	6.5	26	2.5	35	22	27	18	M6	M5
WJRM-01-10-AL	< 0.1	-	18	16.5	6.5	26	2.5	35	22	27	18	M6	M5

WJRM-21 with double roller

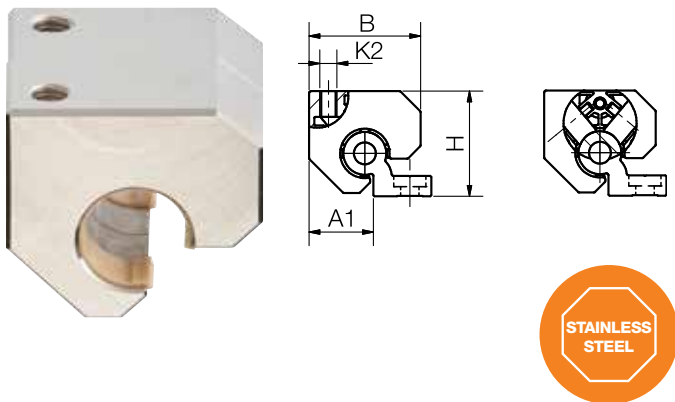

Order key

Type	Size	Material
WJRM-21-20 - ES		
Hybrid roller bearing	Double roller bearing	Size 20
		Stainless steel
Material ES: Stainless steel (AISI 316Ti) ES-FG: Stainless steel precision casting AISI 316		

Technical data and dimensions [mm]

Part No.	Static load capacity Co [N]	Dyn. load capacity Cz+ at total running distance [km]			F · v Max. [N · m/s]
		10	100	200	
WJRM-21-20-ES-FG	840	840	300	150	80

Part No.	coefficient of friction in		Weight [g]	A1	A3	B	C1	C3	G1	H	K2	K3 for screw
	z-direction [μ]	y-direction [μ]										
WJRM-21-20-ES-FG	-	< 0.1	504	30	9	52	52	34	38	49	M8	M5

drylin® W profile guides | Product Range

Round double rails made of 316 stainless steel

drylin®
stainless
steel

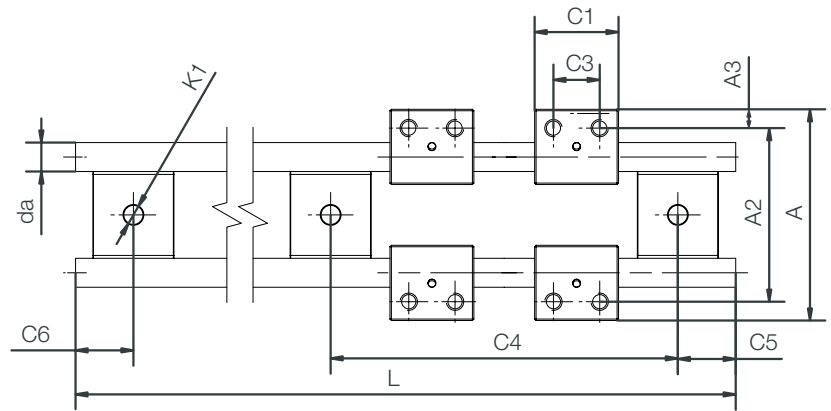

Installation size 10-20

Housing and shaft support material

Shaft material

Installation size 25

Shaft, shaft support and housing material

AISI 316

AISI 316Ti

AISI 316Ti

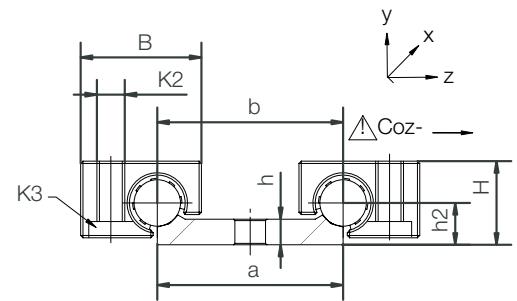

Technical data and dimensions [mm]

Part No.	Weight	H ⁷⁹⁾	da	L	a	b	h	h2	A	A2
	[kg/m]	±0.25	h9	Max.	-0.3					
WS-10-40-ES-FG	1.58	18	10	3,000	40	40	5.5	9	73	60

Part No.	C4	C5	C5	C6	C6	K1 for screw
		Min.	Max.	Min.	Max.	
WS-10-40-ES-FG	120	20	79.5	20	79.5	M6

DIN 912

⁷⁹⁾ Height dimension minus the bearing clearance tolerance

drylin® W profile guides | Product Range

Assembled stainless steel guide carriages, round

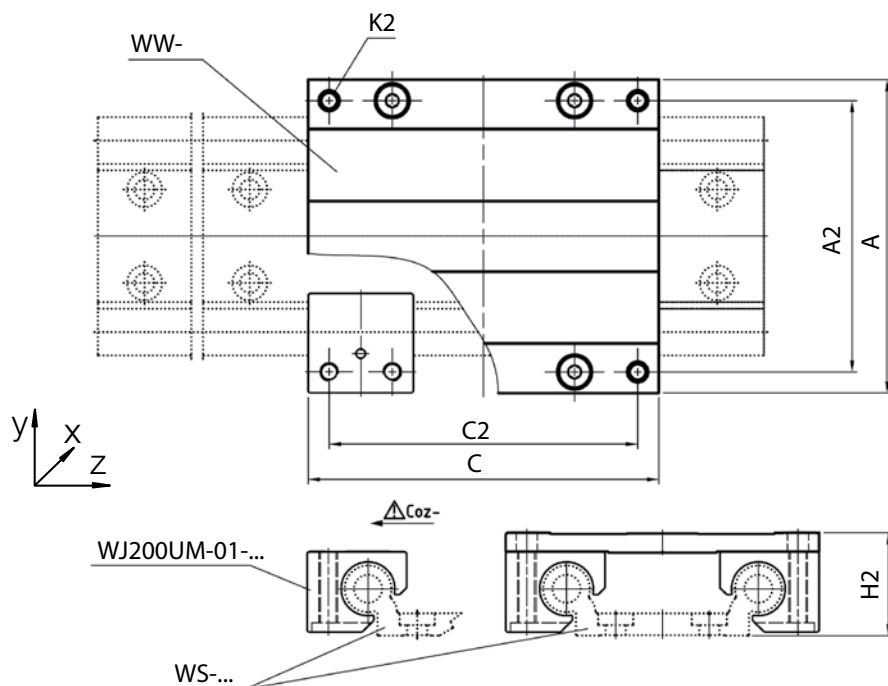

Technical data and dimensions [mm]

Part No. ⁵⁰	Weight [kg]	A	C	A2	C2	K2	H2 ⁵¹	Static load capacity				
								±0.25	Coy	Coz	Mox	Moy
		Width Length										
WW-10-40-10-J200-GESG-PES	0.29	73	100	60	87	M6	24	4,800	2,400	96	170	170
WW-10-40-15-J200-GESG-PES	0.34	73	150	60	137	M6	24	4,800	2,400	96	290	290
WW-10-40-20-J200-GESG-PES	0.40	73	200	60	187	M6	24	4,800	2,400	96	410	410

⁵¹ Height dimension minus the bearing clearance tolerance ⁵⁰ Optionally available with manual clamp, suffix "-HKA"

Notes

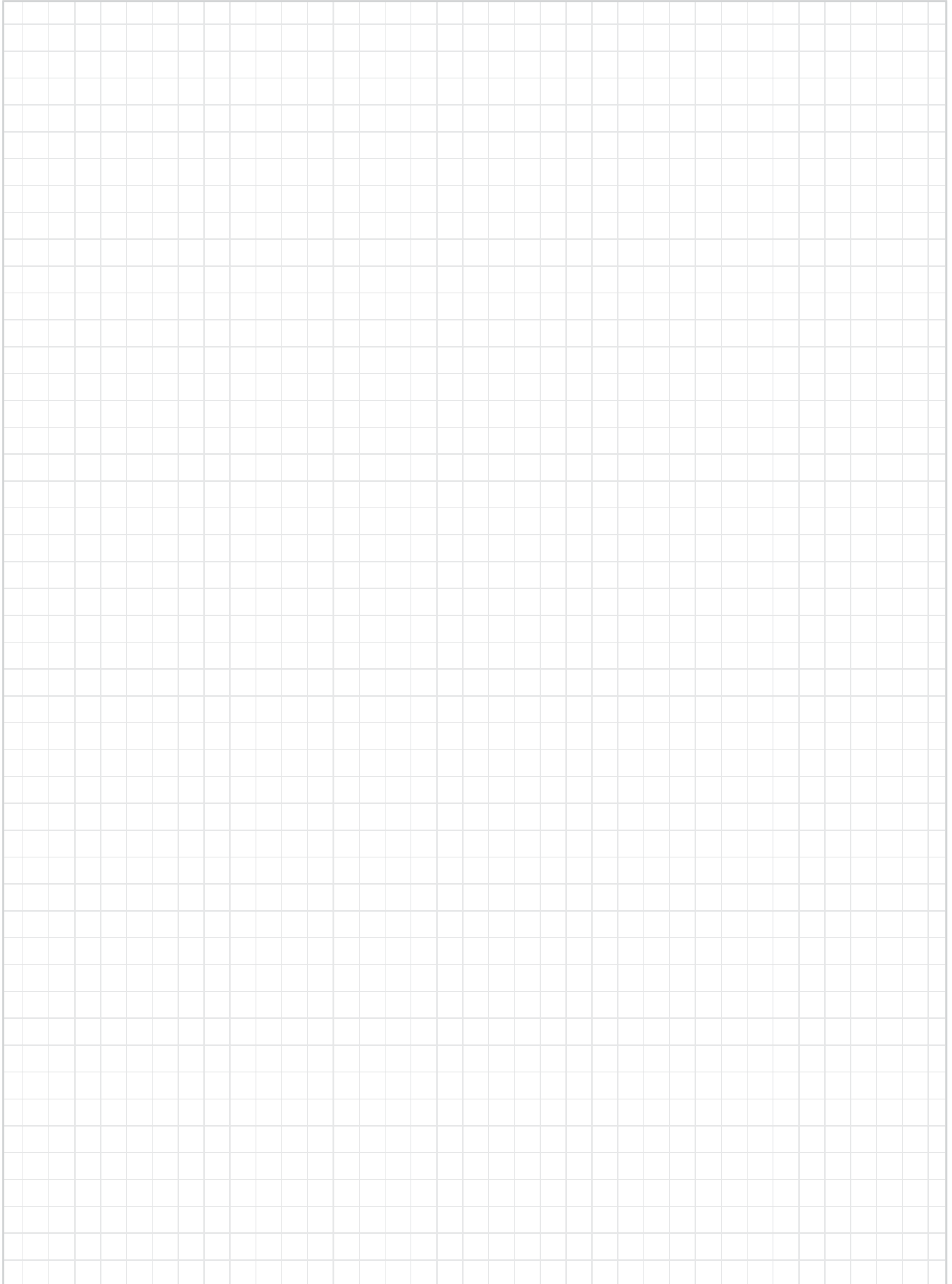

drylin® shafts | Product Range

Stainless steel shafts, inch

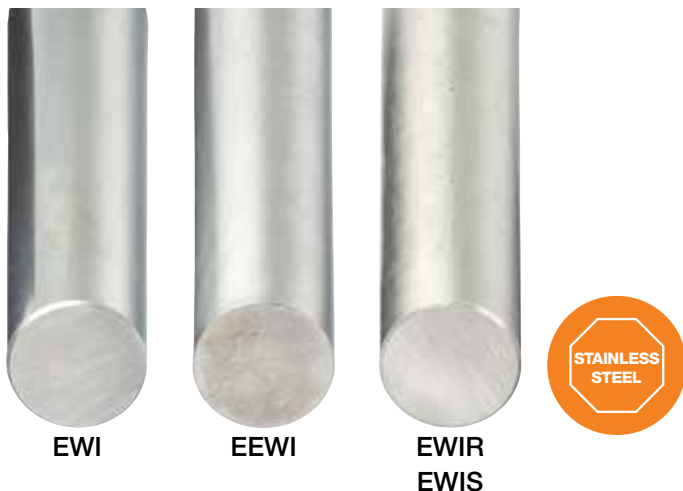

- For supported shafts:
 - ▶ Shaft support supplied in lengths of 600mm max.
 - ▶ Hole pitches symmetrical C5 = C6

Dimensions [mm] – hardened stainless steel 440C (1.4125)

Part No.	Diameter Ø	Weight [lb/ft]	Max. length	Effective hardness depth with 440C (1.4125)
EWI-04	0.25	0.168	12ft	0.027"
EWI-06	0.375	0.372	12ft	0.027"
EWI-08	0.50	0.660	12ft	0.04"
EWI-10	0.625	1.032	12ft	0.04"
EWI-12	0.75	1.500	12ft	0.06"
EWI-16	1.00	2.664	12ft	0.08"
EWI-20	1.25	4.176	12ft	0.08"
EWI-24	1.50	6.000	12ft	0.08"
EWI-32	2.00	10.680	12ft	0.1"

 **Order key**

Type	Size
EW	I -06- <input type="text"/>

Stainless steel shaft 440C	Inch	Outer Ø	Shaft length [inch]
----------------------------	------	---------	---------------------

 **Order key**

Type	Size
EEW	I -06- <input type="text"/>

Stainless steel shaft 420C	Inch	Outer Ø	Shaft length [inch]
----------------------------	------	---------	---------------------

Available shaft materials

Stainless steel 440C (1.4125), hardened/ground ► EWI
 Stainless steel 420C (1.4034), hardened/ground ► EEWI

Available upon request

Stainless steel 304 (1.4301), drawn ► EWIR
 Stainless steel 316 (1.4571), drawn ► EWIS

Dimensions [mm] – hardened stainless steel 420C (1.4034)

Part No.	Diameter Ø	Weight [lb/ft]	Max. length	Effective hardness depth with 420C (1.4034)
EEWI-04	0.25	0.168	9.8ft	0.016"
EEWI-06	0.375	0.372	9.8ft	0.016"
EEWI-08	0.50	0.660	12ft	0.024"
EEWI-10	0.625	1.032	12ft	0.024"
EEWI-12	0.75	1.500	12ft	0.035"
EEWI-16	1.00	2.664	12ft	0.035"
EEWI-20	1.25	4.176	12ft	0.059"
EEWI-24	1.50	6.000	12ft	0.059"
EEWI-32	2.00	10.680	12ft	0.059"

drylin® shafts | Product Range

Supported stainless steel shafts, inch

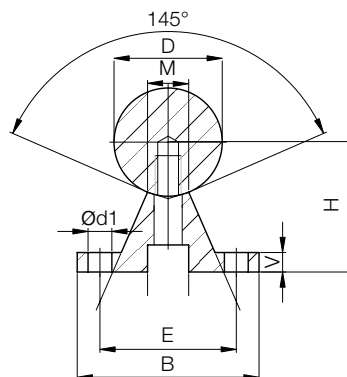

EWUI: Supported stainless steel shaft



igus® recommendation: Linear plain bearings equipped with iglide® E7 liners for 8 times longer service life

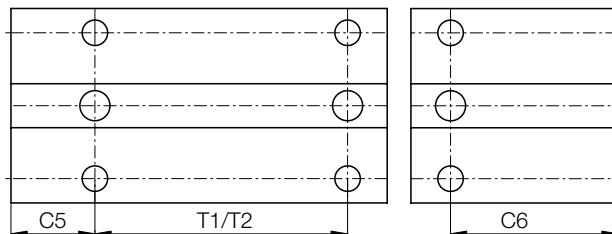

Dimensions [inch] – supported stainless steel shafts 440C (1.4125)

Part No.	D	B	H	V	d1	M	E	T1	C5/C6		Max length*	Weight
									Min.	Max.		
	Ø		+/-				+/-				inches	[lb/ft]
EWUI-08	0.50	1.500	1.125	0.187	0.169	0.250	1.000	4	1	2.95	144	0.7
EWUI-10	0.625	1.625	1.125	0.250	0.193	0.312	1.125	4	1	2.95	144	1.1
EWUI-12	0.75	1.750	1.500	0.250	0.221	0.375	1.250	6	1	3.95	144	1.6
EWUI-16	1.00	2.125	1.750	0.250	0.281	0.500	1.500	6	1	3.95	144	2.8
EWUI-20	1.25	2.500	2.125	0.312	0.330	0.562	1.875	6	1	3.95	144	4.3
EWUI-24	1.50	3.000	2.500	0.375	0.406	0.687	2.250	8	1	4.95	144	6.2
EWUI-32	2.00	3.750	3.250	0.500	0.531	0.875	2.750	8	1	4.95	144	11.0

Notes

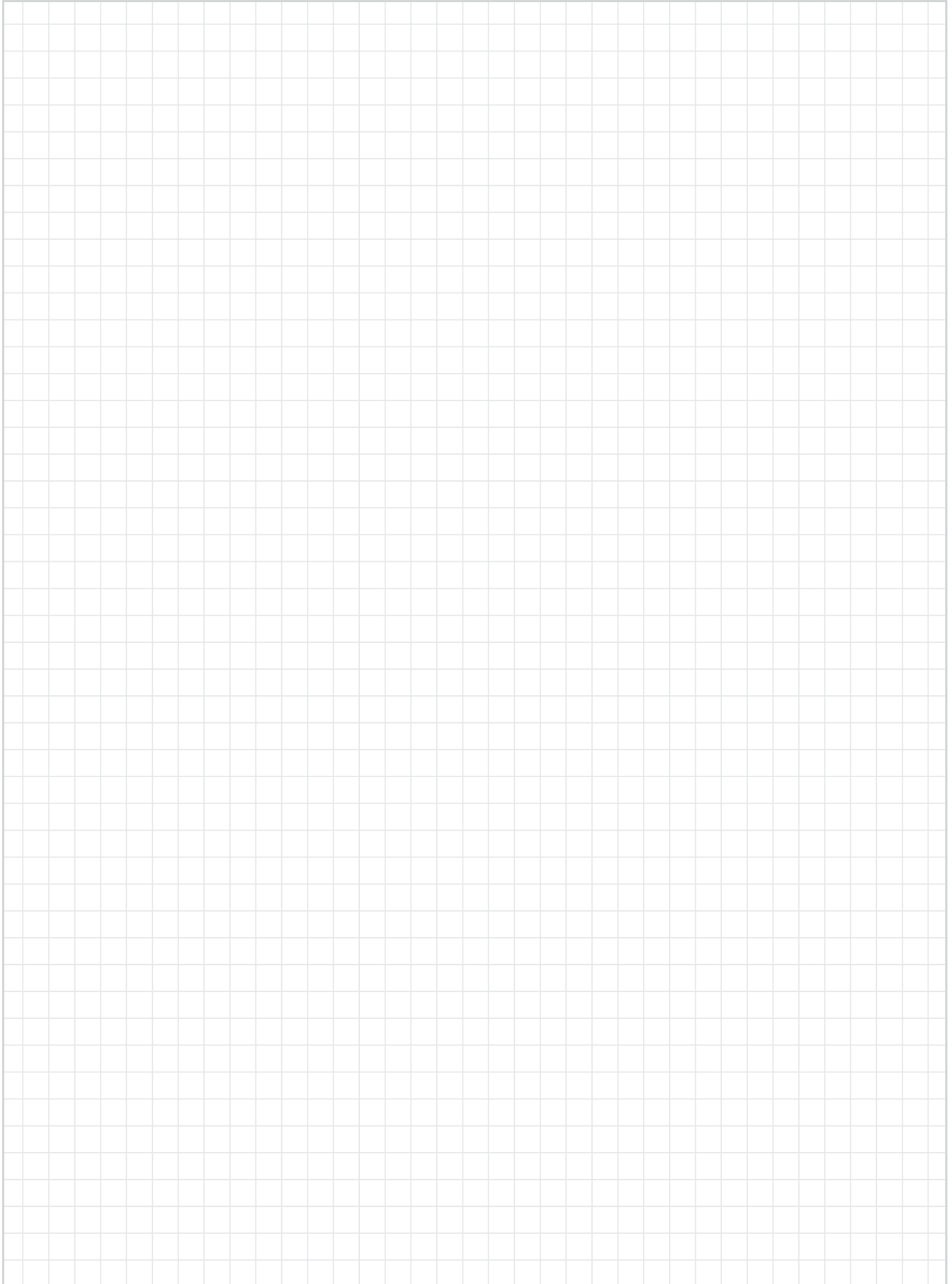



EWM

EEWM

EWMR



Inch shafting available

► Page 1316

- Completely supported and mounted with standard aluminum support
- For supported shafts:
 - ▶ Shaft support supplied in lengths of 600mm max.
 - ▶ Standard pitch T2, T1 also possible upon request
 - ▶ Symmetrical hole pitches C5 = C6

Dimensions [mm] – hardened stainless steel AISI 440B

Part No.	d	Weight [kg/m]	Max. length	Effective hardness depth with 440C (1.4125)
EWM-06 sm	06	0.222	3,000	0.8
EWM-08 sm	08	0.359	4,000	0.9
EWM-10 sm	10	0.617	4,000	0.9
EWM-12	12	0.888	6,000	1.0
EWM-16	16	1.578	6,000	1.2
EWM-20	20	2.466	6,000	1.6
EWM-25	25	3.853	6,000	1.8
EWM-30	30	5.549	6,000	2.0
EWM-40	40	9.865	6,000	2.2
EWM-50	50	15.413	6,000	2.4

Materials: AISI 440B, AISI 420C, AISI 304, AISI 316Ti



Order key

Type Size Options

E W M - 06 - 2000



Available shaft materials

- AISI 440B, hardened/ground ► EWM
- AISI 420C, hardened/ground ► EEWM
- AISI 304, drawn ► EWMR
- AISI 316Ti, drawn ► EWMS

Dimensions [mm] – hardened stainless steel AISI 420C

Part No.	d	Weight [kg/m]	Max. length	Effective hardness depth with 420C (1.4034)
EEWM-06	06	0.222	3,000	0.8
EEWM-08	08	0.359	4,000	0.9
EEWM-10	10	0.617	4,000	0.9
EEWM-12	12	0.888	6,000	1.0
EEWM-16	16	1.578	6,000	1.2
EEWM-20	20	2.466	6,000	1.6
EEWM-25	25	3.853	6,000	1.8
EEWM-30	30	5.549	6,000	2.0
EEWM-40	40	9.865	6,000	2.2
EEWM-50	50	15.413	6,000	2.4

Dimensions [mm] – stainless steel AISI 304 (EWMR) or AISI 316Ti soft stainless steel (EWMS)

Part No.	d	Weight [kg/m]	Max. length
EWMR-10	10	0.617	4,000
EWMS-10	10	0.617	4,000
EWMR-12	12	0.888	6,000
EWMR-16	16	1.578	6,000
EWMR-20	20	2.466	3,000
EWMS-20	20	2.466	6,000
EWMR-25	25	3.853	6,000
EWMR-30	30	5.549	6,000



Order example:

EWM-16-500: Stainless steel shaft (AISI 440B) with 16mm Ø, 500mm in length

Supported stainless steel shafts

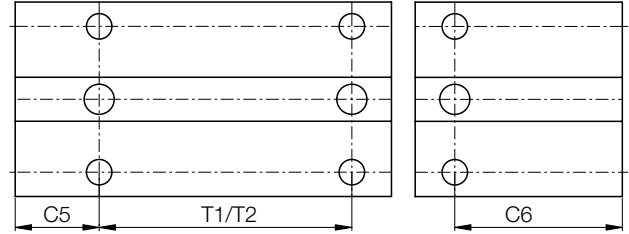
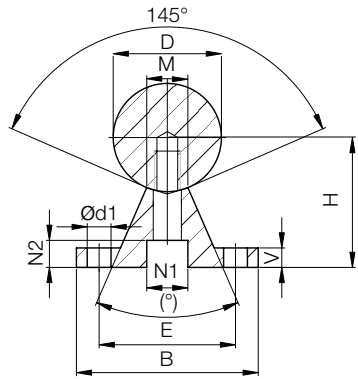

EWUM: Supported stainless steel shaft

Shaft support blocks for Ø 20mm made of stainless steel VA

- Connecting sizes as standard supports made from aluminum



igus® recommendation: Linear plain bearings equipped with iglide® E7 liners for 8 times longer service life

Available materials and lengths:

AISI 440B, max. 6,000mm

Hole pattern:

T2: T2 pitch (standard)

T1: T1 pitch (upon request)

Dimensions [mm] – supported stainless steel shafts AISI 440B

Part No.	D	B	H	V	N1	N2	d1	M	(°)	E	T1 ⁸⁷⁾	C5/C6		T2	C5/C6		Weight
												Min.	Max.	Standard	Min.	Max.	
				±0.02							±0.15	for T1	Standard	for T2	Standard	[kg/m]	
EWUM-12	12	40	22	5	8.0	5.0	4.5	5.8	50	29	75	20	57	120	20	79	1.75
EWUM-16	16	45	26	5	9.5	6.0	5.5	7.0	50	33	100	20	69	150	20	94	2.64
EWUM-20	20	52	32	6	11.0	6.5	6.6	8.3	50	37	100	20	69	150	20	94	3.97
EWUM-25	25	57	36	6	14.0	8.5	6.6	10.8	50	42	120	20	79	200	20	119	5.65
EWUM-30	30	69	42	7	17.0	10.5	9.0	11.0	50	51	150	20	94	200	20	119	7.93
EWUM-40	40	73	50	8	17.0	10.5	9.0	15.0	50	55	200	20	119	300	20	169	12.88
EWUM-50	50	84	60	9	19.0	12.5	11.0	19.0	46	63	200	20	119	300	20	169	19.60

⁸⁷⁾ T1 pitch upon request; standard is T2



Order example:

EWUM-16-500-T1: Supported stainless steel shaft (AISI 440B) with 16mm outer Ø, 500mm length, T1 pitch

drylin® shafts | Product Range

Low level supported stainless steel shafts

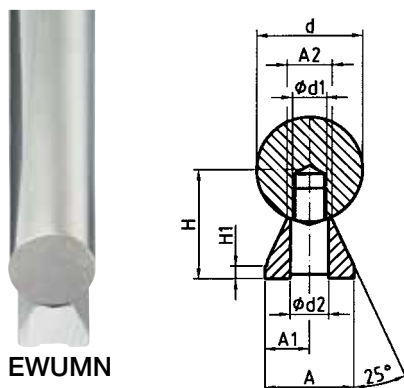

EWUMN

EWUMN: Low level supported stainless steel shaft

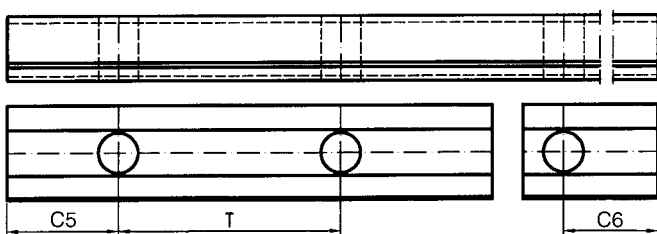

Order key

Type	Size	Options
E W U M N - 20 - 2000 - T1		
Low level supported stainless steel shaft, metric	Outer \emptyset	Shaft length [mm]
		Hole pattern

Dimensions [mm] – low level supported stainless steel shafts AISI 440B

Part No.	Outer \emptyset	H	H1	A	A1	A2	d1	d2	T	C5/C6		Weight [kg/m]
	d	± 0.02				± 0.02				Min.	Max.	
EWUMN-12	12	14.5	3	11	5.5	5.4	M4	4.5	75	20	57	1.62
EWUMN-16	16	18	3	14	7.0	7.0	M5	5.5	75	20	57	2.54
EWUMN-20	20	22	3	17	8.5	8.1	M6	6.6	75	20	57	3.81
EWUMN-25	25	26	3	21	10.5	10.3	M8	9.0	75	20	57	5.62
EWUMN-30	30	30	3	23	11.5	11.0	M10	11.0	100	20	69.5	7.63
EWUMN-40	40	39	4	30	15.0	15.0	M12	13.5	100	20	69.5	13.47
EWUMN-50	50	46	5	35	17.5	19.0	M14	15.5	100	20	69.5	20.31

Low level supported shafts are delivered unmounted.



Order example:

EWUMN-16-500: Low level supported stainless steel shaft (AISI 440B) with 16mm outer \emptyset , 500mm length

drylin® shafts | Product Range

Partially supported stainless steel shafts



EWUM-ES/
EWUMS-ES

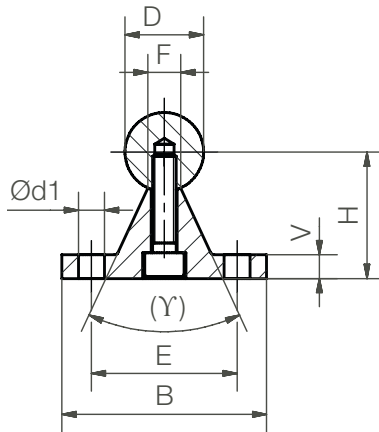

Shaft support blocks for Ø 20mm
made of stainless steel VA

- Connecting sizes as standard supports made from aluminum



igus® recommendation: linear plain bearings equipped with iglide® E7 liners for 8 times longer service life

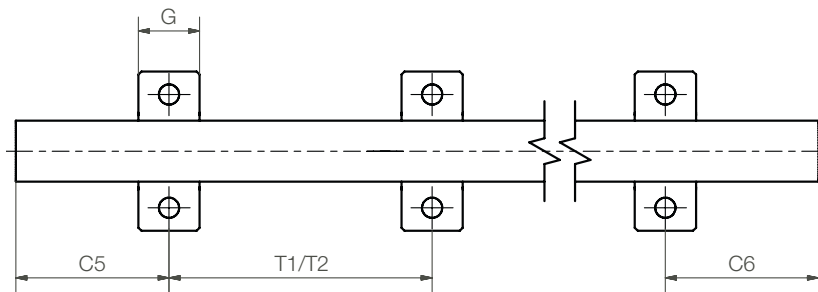

Dimensions [mm] – partially supported stainless steel shafts AISI 440B

Part No.	D	B	H	V	d1	E	Y	F	G	T1	C5/C6		T2	C5/C6	
											for T1		Standard	for T2	
											Min.	Max.		Min.	Max.
EWUM-ES-12	12	40	22	5	4.5	29	–	5.8	14	75	20	57	120	20	79
EWUM-ES-16	16	45	26	5	5.5	33	–	7.0	16	100	20	69	150	20	94
EWUM-ES-20	20	52	32	6	6.6	37	50°	8.3	20	100	20	69	150	20	94
EWUM-ES-25	25	57	36	6	6.6	42	–	10.8	25	150	20	79	200	20	119
EWUM-ES-30	30	69	42	7	9.0	51	–	11.0	25	150	20	94	200	20	119
EWUM-ES-40	40	73	50	8	9.0	55	–	15.0	25	200	20	119	300	20	169

T2 pitch as standard, T1 upon request



Order example:

EWUM-ES-20-500, partially supported stainless steel shaft (shaft and support made of stainless steel), AISI 440B material, T2 pitch, outer Ø 20mm, L = 500mm



Order key

Type	Size	Options
E W U M S - ES - 20 - 500 - T2		
Partially supported stainless steel shaft, metric	Material	Outer Ø
		Shaft length [mm]
		Hole pattern

Available materials and lengths:

AISI 440B, max. 6,000mm

▶ EWUM

AISI 316Ti, max. 3,000mm

▶ EWUMS

Options:

Blank: AISI 440B material**S:** AISI 316Ti**Hole pattern:****T2:** T2 pitch (standard)**T1:** T1 pitch

Dimensions [mm] – partially supported stainless steel shafts AISI 316Ti

Part No.	D	B	H	V	d1	E	γ	F	G	T1	C5/C6		T2	C5/C6		
											for T1			Standard	for T2	
											Min.	Max.			Min.	Max.
	h6		±0.02													
EWUMS-ES-12	12	40	22	5	4.5	29	–	5.8	14	75	20	57	120	20	79	
EWUMS-ES-16	16	45	26	5	5.5	33	–	7.0	16	100	20	69	150	20	94	
EWUMS-ES-20	20	52	32	6	6.6	37	50°	8.3	20	100	20	69	150	20	94	
EWUMS-ES-25	25	57	36	6	6.6	42	–	10.8	25	150	20	79	200	20	119	
EWUMS-ES-30	30	69	42	7	9.0	51	–	11.0	25	150	20	94	200	20	119	
EWUMS-ES-40	40	73	50	8	9.0	55	–	15.0	25	200	20	119	300	20	169	

T2 pitch as standard, T1 upon request



Order example:

EWUM-ES-20-500, partially supported stainless steel shaft (shaft and support made of stainless steel), AISI 316Ti material, T1 pitch, outer Ø 20mm, L = 500mm

drylin® shafts | Product Range

Low level partially supported stainless steel shafts



EWUMN-ES/
EWUMSN-ES

Low level shaft support blocks made of stainless steel

- Connection sizes are identical to low-level aluminum supports ► [Page 1335](#)



igus® recommendation: Linear plain bearings equipped with iglide® E7 liners for 8 times longer service life

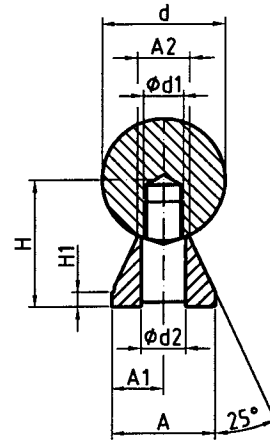
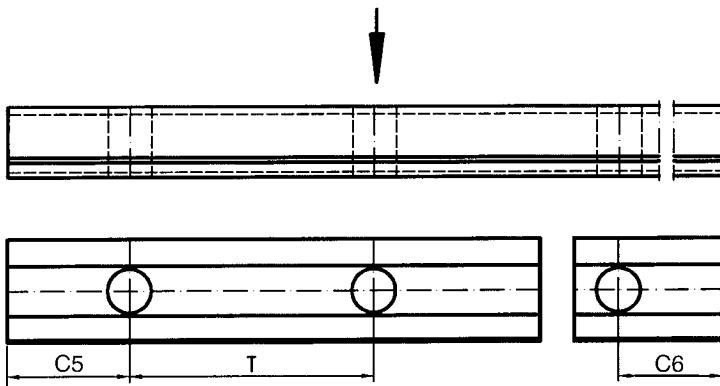

Dimensions [mm] – low level partially supported stainless steel shafts AISI 440B

Part No.	d	H	H1	A	A1	A2	d1	d2	T	C5/C6		Weight [kg/m]
										Min.	Max.	
		±0.02										
EWUMN-ES-12	12	14.5	3	11	5.5	5.4	M4	4.2	75	20	57.0	1.00
EWUMN-ES-16	16	18.0	3	14	7.0	7.0	M5	5.2	75	20	57.0	1.76
EWUMN-ES-20	20	22.0	3	17	8.5	8.1	M6	6.2	75	20	57.0	2.77
EWUMN-ES-25	25	26.0	3	21	10.5	10.3	M8	8.2	75	20	57.0	4.35
EWUMN-ES-30	30	30.0	3	23	11.5	11.0	M10	10.2	100	20	69.5	6.01
EWUMN-ES-40	40	39.0	4	30	15.0	15.0	M12	12.5	100	20	69.5	10.80

Low-level partially supported stainless steel shafts are supplied unassembled



Order example:

EWUMN-ES-20-500: Low level partially supported stainless steel shafts. AISI 440B material, T2 pitch (standard), 20mm outer Ø, 500mm length



Order key

Type	Size	Options
EWUMN S - ES - 20 - 500 - T2		
Partially supported stainless steel shaft, metric	Material	Outer Ø
		Shaft length [mm]
		Hole pattern

Available materials and lengths:

AISI 440B, max. 6,000mm

▶ EWUMN

AISI 316Ti, max. 3,000mm

▶ EWUMSN

Dimensions [mm] – low level partially supported stainless steel shafts AISI 316Ti

Part No.	d	H ±0.02	H1	A	A1	A2	d1	d2	T	C5/C6		Weight [kg/m]
										Min.	Max.	
EWUMSN-ES-12	12	14.5	3	11	5.5	5.4	M4	4.2	75	20	57.0	1.00
EWUMSN-ES-16	16	18.0	3	14	7.0	7.0	M5	5.2	75	20	57.0	1.76
EWUMSN-ES-20	20	22.0	3	17	8.5	8.1	M6	6.2	75	20	57.0	2.77
EWUMSN-ES-25	25	26.0	3	21	10.5	10.3	M8	8.2	75	20	57.0	4.35
EWUMSN-ES-30	30	30.0	3	23	11.5	11.0	M10	10.2	100	20	69.5	6.01
EWUMSN-ES-40	40	39.0	4	30	15.0	15.0	M12	12.5	100	20	69.5	10.80

Low-level partially supported stainless steel shafts are supplied unassembled



Order example:

EWUMSN-ES-20-500-T2: Low-level partially supported stainless steel shaft. AISI 316Ti material, T2 pitch, outer Ø 20mm, length 500mm

Stainless steel linear modules



- Corrosion-resistant carriages and shaft end supports made of stainless steel
- High grade stainless steel shafts
- Stainless steel lead screw
- Standard bearing and nut material iglide® J
- Available with high temperature iglide® X material 356°F (+180°C)
- Available with FDA compliant iglide® A180
- Configure online as SHTC version with short carriages and ball bearings
- High helix lead screw options



Order example

SHT - ES J - 08



See table below for lead options

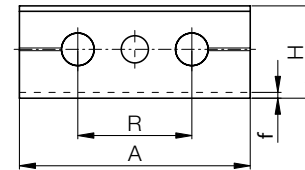
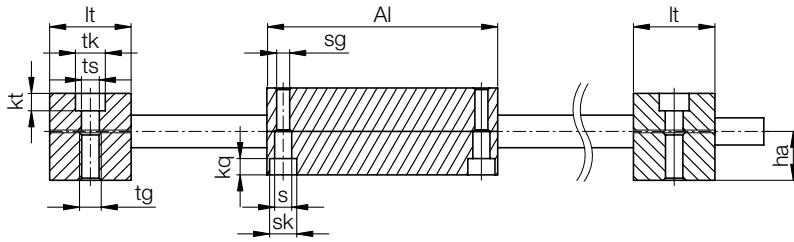

reddot design award
winner 2006

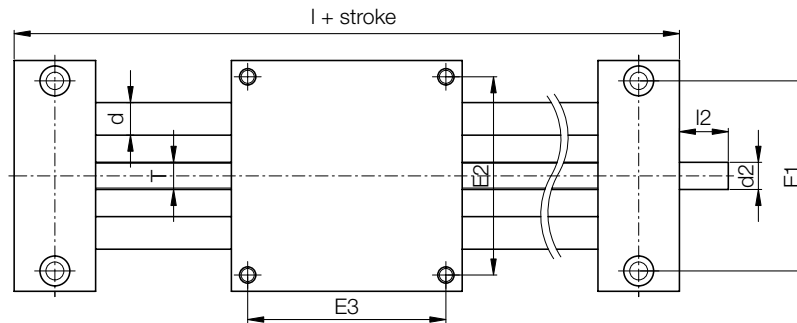

Technical data

Part No.	Max. stroke length [mm]	Steel shaft		Max. static load capacity	
		Weight [kg]	Additional (per 100mm) [kg]	axial [N]	radial [N]
SHT-ESJ-08	300	1.01	0.1	100	360
SHT-ESJ-12	750	2.81	0.24	700	2,800
SHT-ESJ-20	1,000	8.72	0.7	1,600	6,400
SHT-ESJ-30	1,250	24.11	1.47	2,500	10,000

Dimensions [mm]

Part No.	A	Al	H	E1	E2	E3	l	R	f	lt	tk	ts
	-0.3	-0.3		±0.15	±0.15	±0.15						
SHT-ESJ-08	65	65	23	52	55	55	96	32	1.5	15.5	10	5.5
SHT-ESJ-12	85	85	34	70	73	73	145	42	2	30	11	6.6
SHT-ESJ-20	130	130	48	108	115	115	202	72	2	36	15	9.0
SHT-ESJ-30	180	180	68	150	158	158	280	96	4	50	20	13.5

Part No.	tg	kt	s	sk	sg	kq	d	T	l2	d2	ha
	±0.1							Lead		Standard	
SHT-ESJ-08	M6	7	4.2	8	M5	4.6	8	See table for lead options	17	Tr6x2	13
SHT-ESJ-12	M8	6.4	6.3	10	M6	6.0	12		17	Tr10x2 ⁹⁰	18
SHT-ESJ-20	M10	8.6	6.4	11	M8	7.0	20		26	12h9	23
SHT-ESJ-30	M16	12.6	11.0	18	M12	10.6	30		38	14h9	36

⁹⁰ Lead screw end unmachined

Lead Options SHT	
Actuator	Leads (T)
-08	TR 6x2P1
	DS 6.35x2.54
	DS 6.35x5.08
	DS 6.35x12.7
-12	DS 6.35x25.4
	TR 10X2
	TR 10x3
	DS 10x12
	DS 10x25
-20	DS 10x50
	R/L TR 10x2
	R/L DS 10x12
	R/L DS 10x25
	R/L DS 10x50
	TR 18x4
-30	TR 18x8
	DS 18x24
	DS 18x40
	DS 18x80
	DS 18x100
	R/L TR 18x4
-30	R/L DS 18x24
	R/L DS 18x40
	R/L DS 18x80
	TR 24x5
	R/L TR 24x5

drylin® SHT linear actuators | Product Range

drylin®
stainless
steel

Hygienic design



- High helix lead screw options
- Hygienic design for wash-down applications
- Materials: plastic and stainless steel
- Lead screw nuts made of FDA-compliant iglide® A180
- Available accessories ► Page 1703



Order key

Order example

SHTC - 20 - EWM - HYD

Compact	Dimension	Shaft material	Hygienic design
---------	-----------	----------------	-----------------

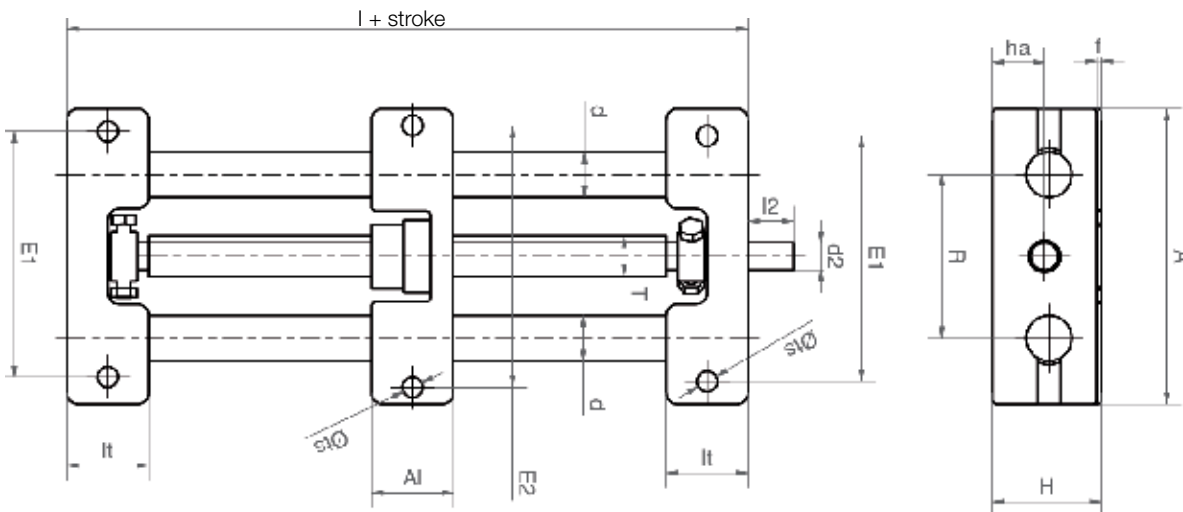

Dimensions [mm]

Part No.	A	A1	H	E1	E2	l	R	f	l _t	ts	d	T	l ₂	d ₂	ha
	-0.3	-0.3		±0.15	±0.15							Lead			
SHTC-20-EWM-HYD	130	35	48	108	115	108	72	2	36	9.0	20	See table	26	12 h9	23

Lead Options SHT	
Actuator	Leads (T)
-20	TR 18x4
	TR 18x8
	DS 18x24
	DS 18x40
	DS 18x80
	DS 18x100
	R/L TR 18x4
	R/L DS 18x24
	R/L DS 18x40
	R/L DS 18x80

drylin® SLW linear actuators | Product Range

Made of stainless steel



- Stainless steel version with corrosion-resistant steel components (AISI 303, AISI 316 and AISI 316Ti)
- Choice of bearing material:
iglide® J = Standard
iglide® A180 = FDA-compliant
iglide® X = High temperature up to 302°F (+150°C)¹¹⁷⁾
- Available accessories ► Page 1703



Order key

Order example

SLW-ES J - 1040

Compact

Stainless steel

Bearing material

Dimension

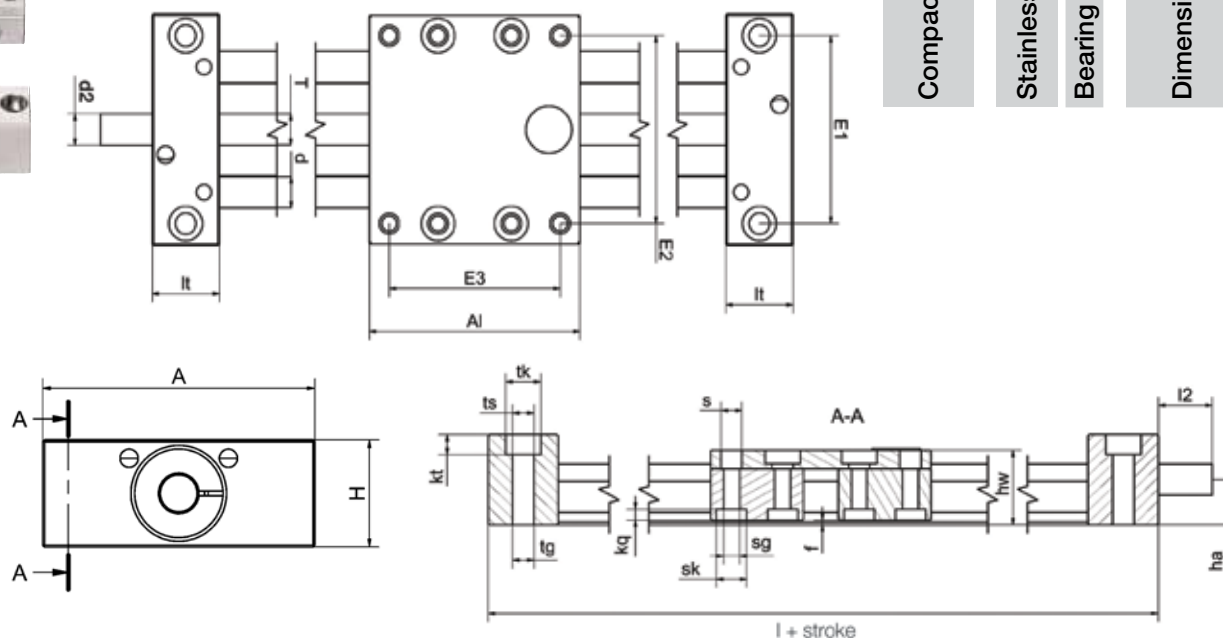

Dimensions [mm]

Part No.	A	A1	H	E1	E2	E3	l	hw	f	lt	lb	tk	ts
	-0.3	-0.3		±0.15	±0.15	±0.15							
SLW-ES-1040	74	100	29	60	60	87	144	24	1.5	22	11	11	6.8
SLW-ES-2080	134	150	46	116	116	132	206	44	1.5	28	14	15	8.6

Part No.	tg	kt	s	sk	sg	kq	d	T (lead)	l2	d2	ha
	±0.1								Standard		
SLW-ES-1040	M8	6.4	6.6	9.5	M6	4.4	10	See table for lead options	17	Tr10x2 ⁹²⁾	14.5
SLW-ES-2080	M10	8.6	9.0	14	M8	5.5	20		26	12h9	23.0

Lead Options	
Actuator	Leads (T)
-1040	TR 10x2
	TR 10x3
	DS 10x12
	DS 10x25
	DS 10x50
	R/L TR 10x2
	R/L DS 10x12
-2080	R/L DS 10x25
	R/L DS 10x50
	TR 18x4
	TR 18x8
	DS 18x24
	DS 18x40
	DS 18x80
	DS 18x100
	R/L TR 18x4
	R/L DS 18x24
	R/L DS 18x40

Technical data

Part No.	Shafts Ø [mm]	Max. stroke length [mm]	Weight [kg]	additional (per 100mm) [kg]	Max. stat. load capacity	
					axial [N]	radial [N]
SLW-ESJ-1040	10	750	1.4	0.2	700	2,800
SLW-ESX-1040	10	750	1.4	0.2	700	2,800
SLW-ESA180-1040	10	750	1.4	0.2	700	2,800
SLW-ESJ-2080	20	1,000	5.7	0.64	1,600	6,400
SLW-ESA180-2080	20	1,000	5.7	0.64	1,600	6,400

⁹²⁾ Lead screw end unmachined

¹¹⁷⁾ In the event of severe temperature fluctuations during transport, storage and use, thermal expansion effects cannot be ruled out

XY-tables – stainless steel version

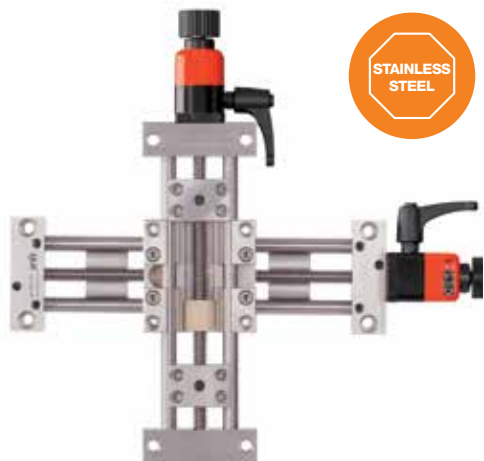

- For manual adjustments
- High torsional stability
- Structure entirely made from 316 stainless steel materials
- Chemical and corrosion-resistant
- Available accessories ► **Page 1703**

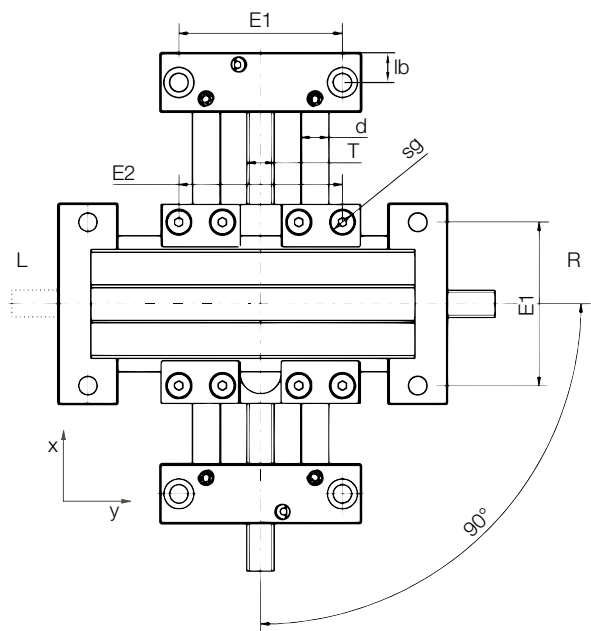
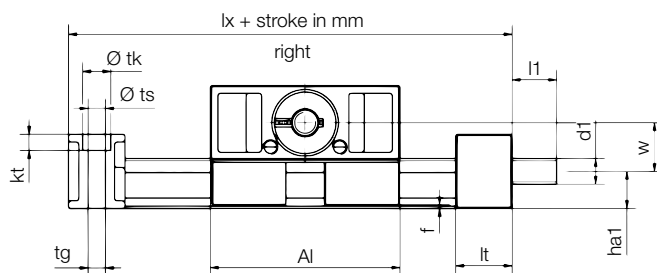
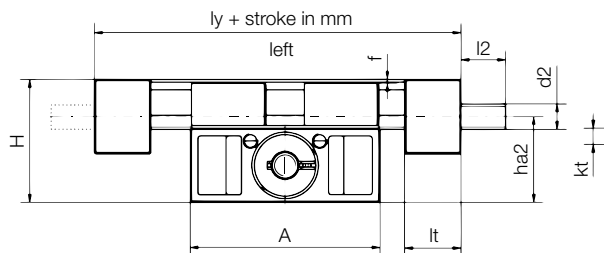

Lead Options	
Actuator	Leads (T)
-1040	TR 10x2
	TR 10x3
	DS 10x12
	DS 10x25
	DS 10x50
	R/L TR 10x2
	R/L DS 10x12
	R/L DS 10x25
-1660	TR 14x4
	DS 14x25
	DS 14x30
	R/L TR 14x4
-2080	TR 18x4
	TR 18x8
	DS 18x24
	DS 18x40
	DS 18x80
	DS 18x100
	R/L TR 18x4
	R/L DS 18x24
R/L DS 18x40	
R/L DS 18x80	

Dimensions [mm]

Part No.	Max. stroke length [mm]	A	Al	H	E1	E2	Base length	Base length	f	lt	lb	tk	ts
		-0.3			±0.15	±0.15	lx	ly				±0.1	
SLW-XY-ESJ-1040	300	74	73	48	60	60	117	117	1.5	22	11	11	6.8

Part No.	tg	kt	sg	d	T (lead)	l1	d1 Std	d1 Alt	l2	d2 Std	d2 Alt	ha1	ha2	W
													ha2-ha1	
SLW-XY-ESJ-1040	M8	6.4	M6	10	Tr10x2	17	Tr10x2	6 h9	17	Tr10x2	6 h9	14.5	33.5	19

The hand wheel can be ordered left or right-mounted in the y-direction.

Left: SLW-XY-ESJ-1040-L-200-300 for 200mm stroke length on the x-axis and 300mm on the y-axis

Right: SLW-XY-ESJ-1040-R-200-300 for 200mm stroke length on the x-axis and 300mm on the y-axis

drylin® ZLW linear actuators | Product Range

Stainless steel toothed belt modular drive system



- High speed possible with ball bearings in end support
- Robust wide timing belt
- Central belt adjustment on the carriage
- Based on self-lubricating drylin® W linear guide
- Variable motor connection due to solid and hollow shafts



Order key

Type Size Options
ZLW-20120-ES-02-S-200-H-2000

Toothed belt axis	Installation size	Axis distance	Design	Version	Version	Carriage length	Drive pin	Stroke length
-------------------	-------------------	---------------	--------	---------	---------	-----------------	-----------	---------------

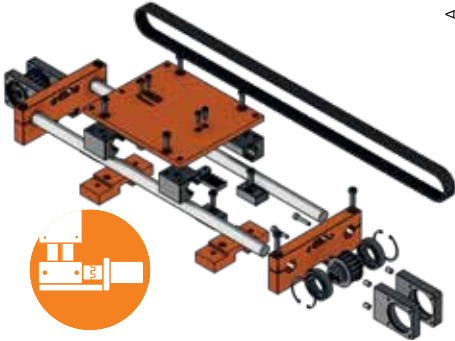
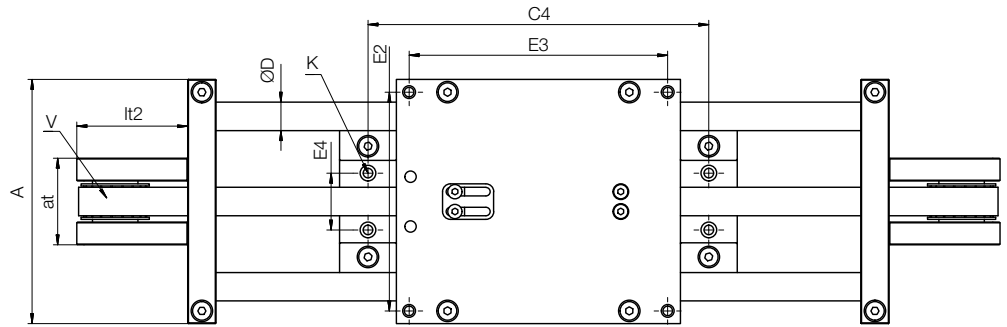
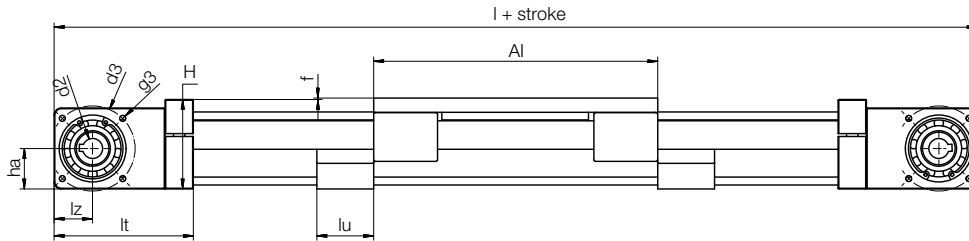

Technical data

Part No.	Max. stroke length [mm]	Transmission [mm/U]	Tooth profile	Drive belt	
				-material	-tension [N]
ZLW-20120-ES	3,000	144	8M	PU with steel cable	750
ZLW-20160-ES	3,000	144	8M	PU with steel cable	750
ZLW-20200-ES	3,000	144	8M	PU with steel cable	750

Dimensions [mm]

Part No.	A	AI	H	E2	E3	E4	C4	f	lt	ha	lz	l	d2	d3	g3	D	K	at	lt2	lu	V	
													h7				For DIN912 - M6					[mm/rev]
ZLW-20120-ES	172	200	63	154	182	40	240	-	98	28.5	27	396	14	60	M5	20	M8	61	78	40	144	
ZLW-20160-ES	212	200	63	194	182	80	240	-	98	28.5	27	396	14	60	M5	20	M8	61	78	40	144	
ZLW-20200-ES	252	200	63	234	182	120	240	-	98	28.5	27	396	14	60	M5	20	M8	61	78	40	144	