



LM Guide Actuator

THK General Catalog

LM Guide Actuator

THK General Catalog

A Product Descriptions

Caged Ball LM Guide Actuator Model SKR ..	A2-4
• Structure and Features	A2-4
• Caged Ball Technology	A2-6
• Types and Configurations.....	A2-9
• Load Ratings in All Directions and Static Permissible Moment ..	A2-11
• Maximum Speeds with Different Strokes ..	A2-16
• Lubrication	A2-18
• Static Safety Factor	A2-19
• Service Life.....	A2-20
• Accuracy Standards	A2-24
• Model Number Coding	A2-28

Dimensional Drawing, Dimensional Table

SKR20 Without Cover, Direct Motor Coupling ..	A2-30
SKR20 With Cover, Direct Motor Coupling ..	A2-31
SKR20 Without Cover, Motor Wrap	A2-32
SKR20 With Cover, Motor Wrap	A2-33
SKR26 Without Cover, Direct Motor Coupling..	A2-34
SKR26 With Cover, Direct Motor Coupling ..	A2-35
SKR26 Without Cover, Motor Wrap	A2-36
SKR26 With Cover, Motor Wrap	A2-37
SKR33 Without Cover, Direct Motor Coupling..	A2-38
SKR33 With Cover, Direct Motor Coupling ..	A2-39
SKR33 Without Cover, Motor Wrap	A2-40
SKR33 With Cover, Motor Wrap	A2-41
SKR33 Without Cover, Direct Motor Coupling..	A2-42
SKR33 With Cover, Direct Motor Coupling ..	A2-43
SKR33 Without Cover, Motor Wrap	A2-44
SKR33 With Cover, Motor Wrap	A2-45
SKR46 Without Cover, Direct Motor Coupling..	A2-46
SKR46 With Cover, Direct Motor Coupling ..	A2-47
SKR46 Without Cover, Motor Wrap	A2-48
SKR46 With Cover, Motor Wrap	A2-49
SKR46 Without Cover, Direct Motor Coupling..	A2-50
SKR46 With Cover, Direct Motor Coupling ..	A2-51
SKR46 Without Cover, Motor Wrap	A2-52
SKR46 With Cover, Motor Wrap	A2-53
SKR55 Without Cover, Direct Motor Coupling..	A2-54
SKR55 With Cover, Direct Motor Coupling ..	A2-55
SKR55 Without Cover, Motor Wrap	
Motor Flange Angle, 60×60	A2-56
SKR55 With Cover, Motor Wrap	
Motor Flange Angle, 60×60	A2-57
SKR55 Without Cover, Motor Wrap	
Motor Flange Angle, 80×80	A2-58
SKR55 With Cover, Motor Wrap	
Motor Flange Angle, 80×80	A2-59
SKR65 Without Cover, Direct Motor Coupling..	A2-60
SKR65 With Cover, Direct Motor Coupling ..	A2-61

SKR65 Without Cover, Motor Wrap	A2-62
SKR65 With Cover, Motor Wrap	A2-63
• Mass of Moving Elements	A2-64

Options	A2-65
QZ Lubricator	A2-65
Bellows	A2-76
Sensor	A2-81
Intermediate Flange (Direct Coupling)...	A2-85
Intermediate Flange (Motor Wrap) ..	A2-89

LM Guide Actuator Model KR	A2-112
• Structure and Features	A2-112
• Types and Configurations.....	A2-116
• Load Ratings in All Directions and Static Permissible Moment ..	A2-118
• Maximum Speeds with Different Strokes ..	A2-124
• Lubrication	A2-126
• Static Safety Factor	A2-127
• Service Life	A2-128
• Accuracy Standards	A2-132
• Model Number Coding	A2-136

Dimensional Drawing, Dimensional Table

KR15 Without Cover, Direct Motor Coupling ..	A2-138
KR15 With Cover, Direct Motor Coupling ..	A2-139
KR15 Without Cover, Motor Wrap	A2-140
KR15 With Cover, Motor Wrap	A2-141
KR20 Without Cover, Direct Motor Coupling ..	A2-142
KR20 With Cover, Direct Motor Coupling ..	A2-143
KR20 Without Cover, Motor Wrap	A2-144
KR20 With Cover, Motor Wrap	A2-145
KR26 Without Cover, Direct Motor Coupling ..	A2-146
KR26 With Cover, Direct Motor Coupling ..	A2-147
KR26 Without Cover, Motor Wrap	A2-148
KR26 With Cover, Motor Wrap	A2-149
KR30H Without Cover, Direct Motor Coupling ..	A2-150
KR30H With Cover, Direct Motor Coupling ..	A2-151
KR30H Without Cover, Motor Wrap	A2-152
KR30H With Cover, Motor Wrap	A2-153
KR30H Without Cover, Direct Motor Coupling..	A2-154
KR30H With Cover, Direct Motor Coupling ..	A2-155
KR30H Without Cover, Motor Wrap	A2-156
KR30H With Cover, Motor Wrap	A2-157
KR33 Without Cover, Direct Motor Coupling ..	A2-158
KR33 With Cover, Direct Motor Coupling ..	A2-159
KR33 Without Cover, Motor Wrap	A2-160
KR33 With Cover, Motor Wrap	A2-161
KR33 Without Cover, Direct Motor Coupling ..	A2-162
KR33 With Cover, Direct Motor Coupling ..	A2-163

B Support Book (Separate)

KR33 Without Cover, Motor Wrap	A2-164
KR33 With Cover, Motor Wrap	A2-165
KR45H Without Cover, Direct Motor Coupling ..	A2-166
KR45H With Cover, Direct Motor Coupling ..	A2-167
KR45H Without Cover, Motor Wrap	A2-168
KR45H With Cover, Motor Wrap	A2-169
KR45H Without Cover, Direct Motor Coupling ..	A2-170
KR45H With Cover, Direct Motor Coupling ..	A2-171
KR45H Without Cover, Motor Wrap	A2-172
KR45H With Cover, Motor Wrap	A2-173
KR46 Without Cover, Direct Motor Coupling ...	A2-174
KR46 With Cover, Direct Motor Coupling	A2-175
KR46 Without Cover, Motor Wrap	A2-176
KR46 With Cover, Motor Wrap	A2-177
KR46 Without Cover, Direct Motor Coupling ..	A2-178
KR46 With Cover, Direct Motor Coupling ..	A2-179
KR46 Without Cover, Motor Wrap	A2-180
KR46 With Cover, Motor Wrap	A2-181
KR55 Without Cover, Direct Motor Coupling ..	A2-182
KR55 With Cover, Direct Motor Coupling ..	A2-183
KR55 Without Cover, Motor Wrap Motor Flange Angle, 60×60	A2-184
KR55 With Cover, Motor Wrap Motor Flange Angle, 60×60	A2-185
KR55 Without Cover, Motor Wrap Motor Flange Angle, 80×80	A2-186
KR55 With Cover, Motor Wrap Motor Flange Angle, 80×80	A2-187
KR65 Without Cover, Direct Motor Coupling ..	A2-188
KR65 With Cover, Direct Motor Coupling ..	A2-189
KR65 Without Cover, Motor Wrap	A2-190
KR65 With Cover, Motor Wrap	A2-191
• Mass of Moving Elements	A2-192
Options	A2-193
QZ Lubricator	A2-193
Bellows	A2-204
Sensor	A2-210
Intermediate Flange (Direct Coupling) ..	A2-214
Intermediate Flange (Motor Wrap)	A2-218
XY Bracket (for Reference)	A2-248
Model No.	A2-252
Precautions on Use	A2-254

Features	B2-6
Features of the LM Guide Actuator	B2-6
• Structure and Features	B2-6
• Caged Ball Technology (SKR)	B2-8
• Types and Configurations	B2-9
Point of Selection	B2-11
Static Safety Factor	B2-11
Service Life	B2-12
Example of Calculating the Nominal Life ..	B2-15
Options	B2-24
QZ Lubricator	B2-25
Cover	B2-25
Bellows	B2-26
Sensor	B2-26
XY Bracket (for Reference)	B2-27
Model No.	B2-28
Precautions on Use	B2-30

SKR



Caged Ball LM Guide Actuator Model SKR

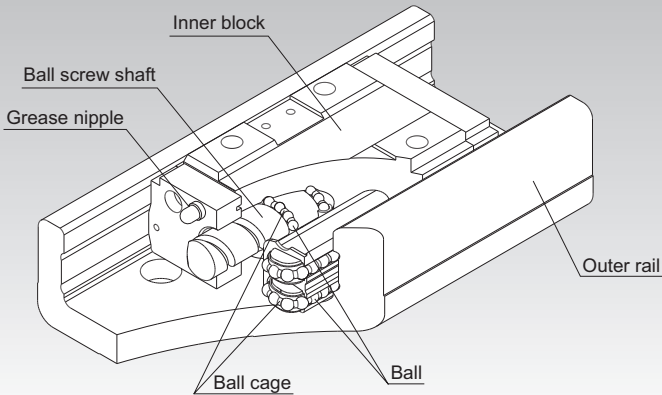

Fig.1 Structure of Caged Ball LM Guide Actuator Model SKR

Structure and Features

Caged Ball LM Guide Actuator model SKR is a compact actuator that has a inner block consisting of LM blocks and a ball screw nut integrated inside a U-shaped outer rail.

In addition, this model achieves high speed operation, lower noise and longer-term maintenance-free operation by using ball cages in the LM Guide units and the Ball Screw unit. (A ball cage is used only for the LM guide section of models SKR20 and SKR26 and the ball screws are fitted with QZ lubricators.)

[4-way Equal Load]

Each row of balls is arranged at a contact angle of 45° so that the rated load on the inner block is uniform under loads applied to the inner block in the four directions (radial, reverse radial and lateral directions). As a result, model SKR can be used in any mounting orientation.

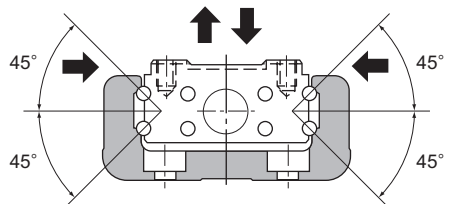

Fig.2 Load Capacity and Contact Angle of Model SKR

[High Rigidity]

Use of an outer rail with a U-shaped cross section increases the rigidity with respect to moment and torsion.

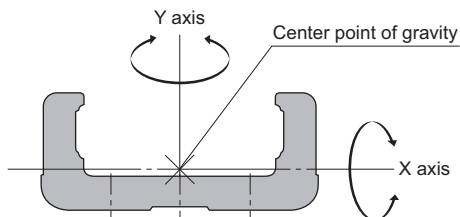

Fig.3 Cross Section of the Outer Rail

Table1 Cross-sectional Characteristics of the Outer rail Rail

Model No.	I_x [mm ⁴]	I_y [mm ⁴]	Mass[kg/m]
SKR20	6.0×10^3	6.14×10^4	2.6
SKR26	1.66×10^4	1.48×10^5	3.9
SKR33	5.35×10^4	3.52×10^5	6.1
SKR46	2.05×10^5	1.45×10^6	12.6
SKR55	2.07×10^5	2.09×10^6	13.2
SKR65	4.51×10^5	5.73×10^6	22.1

I_x =geometrical moment of inertia around X axis

I_y =geometrical moment of inertia around Y axis

[High Accuracy]

Since the linear guide consists of four rows of circular-arc grooves that enable balls to smoothly move with two points of contact even under a preload, a highly rigid guide with no clearance is achieved. Additionally, variation in frictional resistance caused by load fluctuation is minimized, allowing highly accurate feeding. The system contributes significantly to increasing precision and quality by providing precision-grade positioning performance to all kinds of machines.

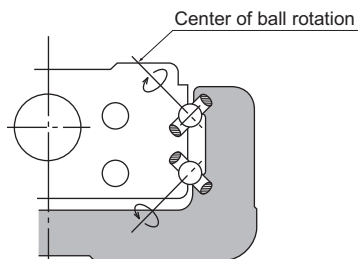

Fig.4 Contact Structure of SKR

[Space Saving]

Due to an integral structure where LM Guide units are placed on both side faces of the inner block and a Ball Screw unit is placed in the center of the inner block, a highly rigid and highly accurate actuator with a minimal space is achieved.

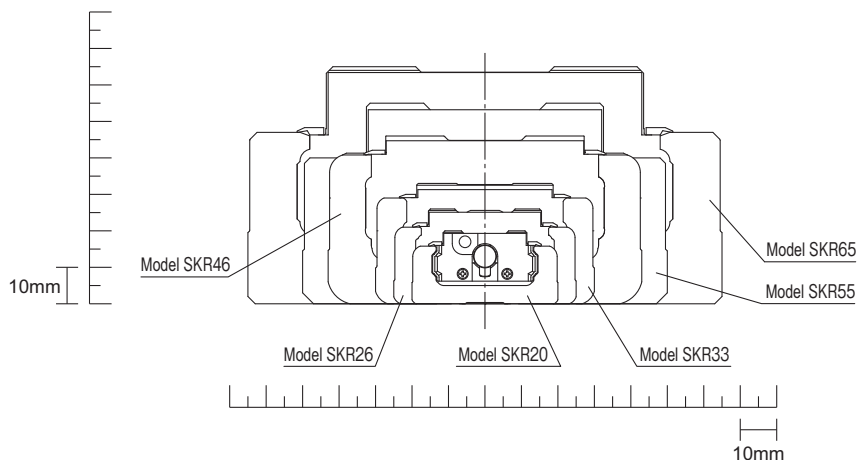

Fig.5 Cross Sectional Drawing

Caged Ball Technology

[High Speed]

Model SKR supports a latest high-rotation servomotor (6,000 min⁻¹) by using a ball cage and is capable of operating at higher speed than the full-ball type model KR.

Models SKR33/55/65 are available in more leads variations to achieve higher speed operation and high leads are available which was not feasible with the model KR.

Model No.	Lead	
	SKR	KR
33	6, 10, 20	6, 10
55	20, 30, 40	20
65	20, 25, 30, 50	25

[High Lubricity]

Model SKR uses ball cages to eliminate friction between balls and significantly improve torque characteristics. As a result, the torque fluctuation is reduced and superb lubricity is achieved.

Item	Description
Shaft diameter/lead	φ13/10mm
Shaft rotation speed	60min ⁻¹

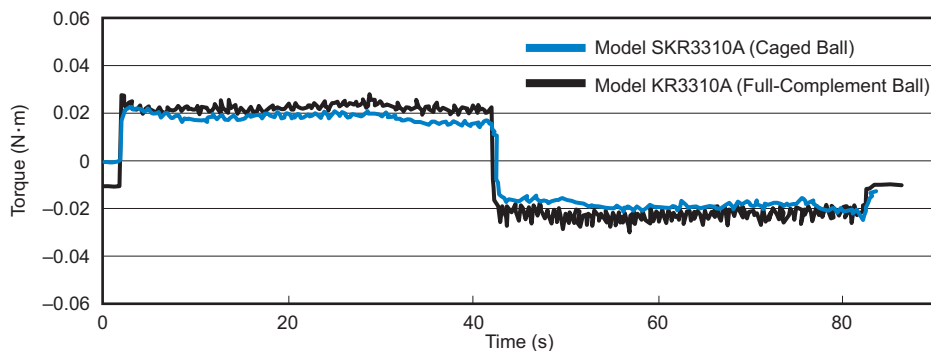

Fig.6 Comparison of Torque Fluctuation between Model SKR and Model KR

[Low Noise, Acceptable Running Sound]

In model SKR, the use of a ball cage in the LM Guide section and Ball Screw section (excluding models SKR20/26) has eliminated collision noise between the balls. As a result, low noise and acceptable running sound are achieved.

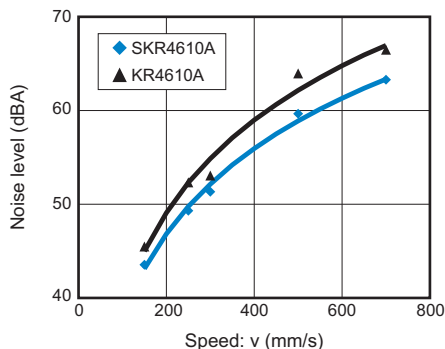

Fig.7 Comparison of Noise between Model SKR4610A and Model KR4610A

[Long-term Maintenance-free Operation]

With model SKR, the ball cage effect helps increase grease retention and achieve long-term maintenance-free operation.

[Long service life—3 times]

With model SKR, both the LM Guide unit and the Ball Screw unit have larger basic dynamic load ratings than the full-ball type model KR, and therefore a longer service lives are achieved.

The rated service life is calculated from the following equation.

LM guide unit

$$L_{10} = (C/P)^3 \times 50$$

L_{10} : Nominal life (km)

C : Basic dynamic load rating (N)

P : Applied load (N)

Ball screw unit

$$L_{10} = (Ca/Fa)^3 \times 10^6$$

L_{10} : Nominal life (rev)

Ca : Basic dynamic load rating (N)

Fa : Applied axial load (N)

As indicated in the equation above, the greater the basic dynamic load rating, the longer the service life of both the LM Guide unit and the Ball Screw unit.

Table2 Comparison of Basic Dynamic Load Rating between Model SKR and Model KR

Unit: N

Basic dynamic load rating		SKR 20	KR 20	SKR 26	KR 26	SKR 33	KR 33	SKR 46	KR 46	SKR 55	KR 55	SKR 65	KR 65
LM guide unit C	Long type block	6010	3590	13000	7240	17000	11600	39500	27400	55400	38100	74400	50900
	Short type block	—	—	—	—	11300	4900	28400	14000	—	—	—	—
Ball screw unit Ca		660	660	2350	2350	2700	1760	4240	3040	10900	3620	12000	5680

Note) On the SKR20/26, only the LM guide section features a ball cage.

[Seal]

Model SKR is equipped with end seals and side seals for dust prevention as standard.

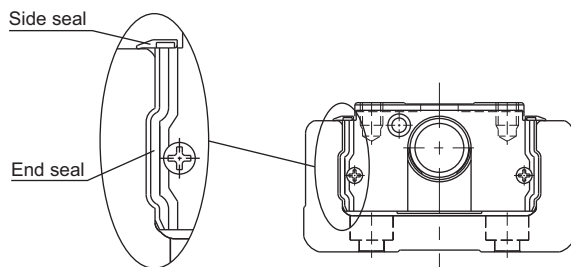

Table3 shows the rolling resistance and seal resistance per inner block (guide section).

Table3 Maximum Resistance Value Unit: N

Model No.	Rolling resistance value	Seal resistance value	Total
SKR20	4.0	0.8	4.8
SKR26	4.5	1.2	5.7
SKR33	3.0	1.7	4.7
SKR46	6.0	2.1	8.1
SKR55	14.0	3.8	17.8
SKR65	20.0	4.1	24.1

Types and Configurations

[Types]

Model SKR-A (with a Single Long Type Block)

Representative model of SKR.

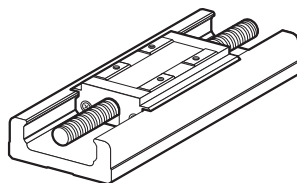

Model SKR-A

Model SKR-B (with Two Long Type Blocks)

Equipped with two units of the inner block of model SKR-A, this model achieves higher rigidity and higher load carrying capacity.

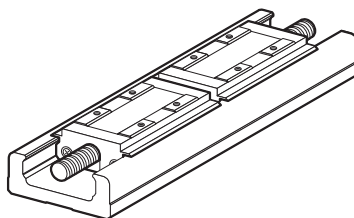

Model SKR-B

Model SKR-C (with a Single Short Type Block)

This model has a shorter overall length of the inner block and a longer stroke than model SKR-A.

(Applicable models: SKR33, 46)*

* With model SKR3320, a short-block type is not available.

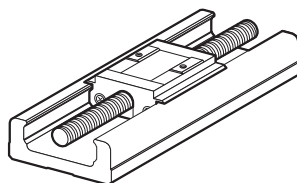

Model SKR-C

Model SKR-D (with Two Short Type Blocks)

Equipped with two units of the inner block of model SKR-C, this design allows a span between blocks that suits the equipment, thereby achieving high rigidity.

(Applicable models: SKR33, 46)*

* With model SKR3320, a short-block type is not available.

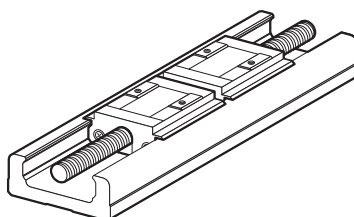

Model SKR-D

[Configurations]

Direct motor coupling (without cover)

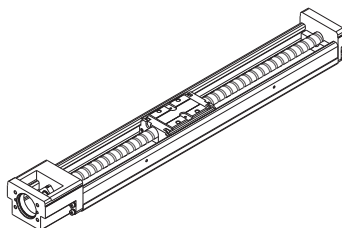

Direct motor coupling (with cover)

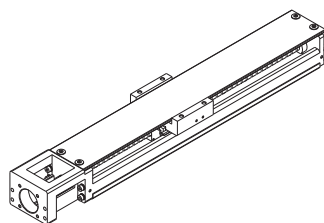

Motor wrap (without cover)

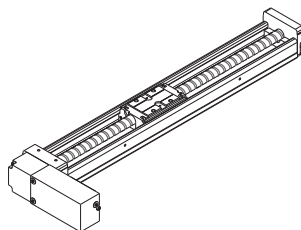

Motor wrap (with cover)

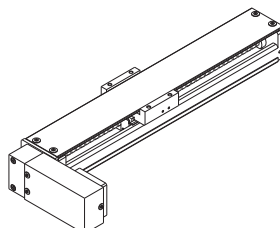

Load Ratings in All Directions and Static Permissible Moment

[Load Rating]

Caged Ball LM Guide Actuator Model SKR consists of an LM Guide, a Ball Screw and a support bearing.

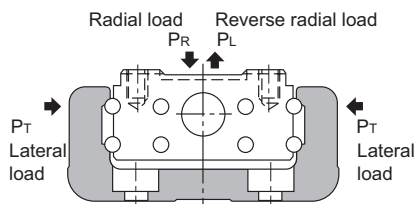

● LM Guide Unit

Model SKR is capable of receiving loads in four directions (radial, reverse radial and lateral directions). Its basic load ratings are equal in all four directions (radial, reverse radial and lateral directions), and their values are indicated in Table4.

● Ball Screw Unit

Since the inner block is incorporated with a ball screw nut, model SKR is capable of receiving an axial load. The basic load rating value is indicated in Table4.

● Bearing Unit (Fixed Side)

Since housing A contains an angular bearing, model SKR is capable of receiving an axial load. The basic load rating value is indicated in Table4.

[Equivalent Load (LM Guide Unit)]

The equivalent load when the LM Guide unit of model SKR simultaneously receives loads in all directions is obtained from the following equation.

$$P_E = P_R (P_L) + P_T$$

P_E	: Equivalent load	(N)
	: Radial direction	
	: Reverse radial direction	
	: Lateral directions	
P_R	: Radial load	(N)
P_L	: Reverse radial load	(N)
P_T	: Lateral load	(N)

Table4 Load Rating of Model SKR

Model No.			SKR20		SKR26		SKR33*		
			SKR2001	SKR2006	SKR2602	SKR2606	SKR3306	SKR3310	SKR3320
LM guide unit	Basic dynamic load rating C (N)	Long type block	6010		13000		17000		
		Short type block	—		—		11300	—	
	Basic static load rating C ₀ (N)	Long type block	8030		16500		20400		
		Short type block	—		—		11500	—	
	Radial clearance (mm)	Normal grade, high accuracy grade	-0.004 to 0		-0.006 to 0		-0.004 to 0		
		Precision grade	-0.006 to -0.004		-0.007 to -0.006		-0.012 to -0.004		
Ball screw unit	Basic dynamic load rating C _a (N)	Normal grade, high accuracy grade	660	860	2350	1950	4400	2700	2620
		Precision grade	660	1060	2350	2390			
	Basic static load rating C _{0a} (N)	Normal grade, high accuracy grade	1170	1450	4020	3510	6290	3780	3770
		Precision grade	1170	1600	4020	3900			
	Screw shaft diameter (mm)		6		8		13		
	Ball Screw lead (mm)		1	6	2	6	6	10	20
	Thread minor diameter (mm)		5.3	5.0	6.6	6.7	10.8		
	Ball center-to-center diameter (mm)		6.15	6.3	8.3	8.4	13.5		
Bearing unit (Fixed side)	Axial direction	Basic dynamic load rating C _a (N)	1150		2000		6250		
		Static permissible load P _{0a} (N)	735		1230		2700		

*For use in a special environment or where an axial load (25% or more of the basic dynamic load rating C_a) is applied, a special type is also available. Contact THK for details.

Note1) The load ratings in the LM Guide unit each indicate the load rating per inner block.

Note2) With model SKR3320, a short-block type is not available.

SKR46*		SKR55			SKR65			
SKR4610	SKR4620	SKR5520	SKR5530	SKR5540	SKR6520	SKR6525	SKR6530	SKR6550
39500		55400			74400			
28400		—			—			
45900		62500			81600			
28700		—			—			
-0.006 to 0		-0.007 to 0			-0.008 to 0			
-0.016 to -0.006		-0.019 to -0.007			-0.022 to -0.008			
4350	4240	10900	7000	6800	12100	12000	8200	7600
6990	7040	17600	11500	9900	21600	22000	14500	12600
15		20			25			
10	20	20	30	40	20	25	30	50
12.5		17.1			22.1			
15.75		20.75			25.75			
6700		7600			13700			
3330		3990			5830			

[Static Permissible Moment (LM Guide Unit)]

The Inner block is capable of receiving moment loads in all three (3) directions.

A2-15 Table 5 shows the permissible static moment in the M_A , M_B and M_C directions.

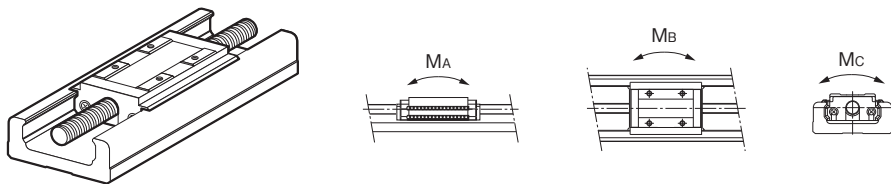

With a single long type block (Model SKR-A)

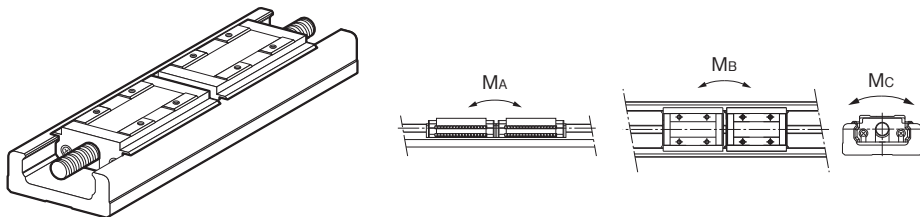

With double long type blocks (Model SKR-B)

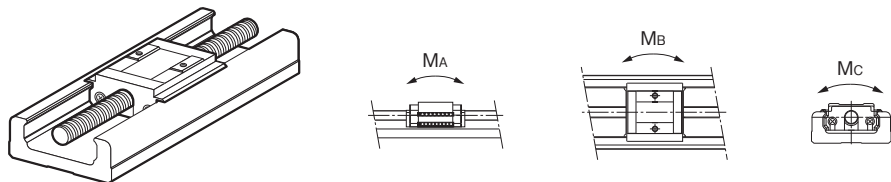

With a single short type block (Model SKR-C)

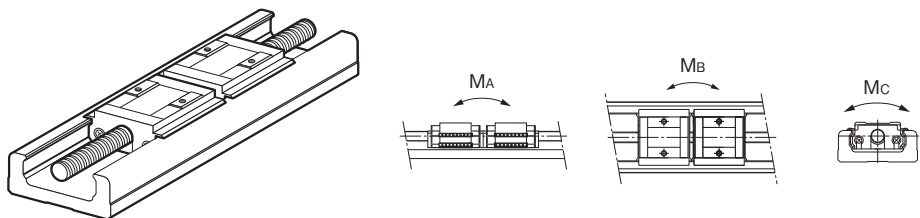

With double short type blocks (Model SKR-D)

Table5 Static Permissible Moments of Model SKR

Unit: N·m

Model No.	Static permissible moment		
	M _A	M _B	M _C
SKR20-A	38 (9)	38 (8)	98 (13)
SKR20-B	207 (39)	207 (32)	197 (27)
SKR26-A	117 (31)	117 (22)	265 (30)
SKR26-B	589 (154)	589 (78)	530 (60)
SKR33-A	173 (38)	173 (40)	424 (51)
SKR33-B	990 (172)	990 (158)	848 (103)
SKR33-C	58 (8)	58 (14)	240 (17)
SKR33-D	390 (55)	390 (56)	480 (51)
SKR46-A	579 (34)	579 (98)	1390 (34)
SKR46-B	3240 (162)	3240 (364)	2780 (68)
SKR46-C	236 (17)	236 (34)	870 (17)
SKR46-D	1460 (56)	1460 (135)	1740 (34)
SKR55-A	923 (169)	923 (212)	2276 (169)
SKR55-B	5125 (863)	5125 (831)	4552 (338)
SKR65-A	1366 (326)	1366 (448)	3868 (326)
SKR65-B	7702 (1349)	7702 (1512)	7736 (653)

Note1) Symbols A, B, C or D in the end of each model number indicates the inner block size and the number of inner blocks used.

A: With a single long type block

B: With double long type blocks

C: With a single short type block

D: With double short type blocks

Note2) The values for models SKR-B/D indicate the values when double inner blocks are used in close contact with each other.

Note3) Static permissible moment is the maximum moment that can be permitted while the product is stationary.

Note4) Values in parentheses are with a cover or bellows.

Maximum Speeds with Different Strokes

Table6 Maximum speed

Model No.	Ball screw lead (mm)	Stroke* (mm)		Outer rail length (mm)	Maximum speed (mm/s)	
		Long type block	Short type block		Long type block	Short type block
SKR20	1	30	—	100	100	—
		80	—	150	100	—
		130	—	200	100	—
	6	30	—	100	600	—
		80	—	150	600	—
		130	—	200	600	—
SKR26	2	60	—	150	200	—
		110	—	200	200	—
		160	—	250	200	—
		210	—	300	200	—
	6	60	—	150	600	—
		110	—	200	600	—
SKR33	6	160	—	250	600	—
		210	—	300	600	—
		45	70	150	600	600
		95	120	200	600	600
		195	220	300	600	600
		295	320	400	600	600
	10	395	420	500	600	600
		495	520	600	550	500
		595	620	700	390	360
		45	70	150	1000	1000
		95	120	200	1000	1000
		195	220	300	1000	1000
	20	295	320	400	1000	1000
		395	420	500	1000	1000
		495	520	600	920	830
		595	620	700	650	600
		45	—	150	2000	—
		95	—	200	2000	—
SKR46	10	195	—	300	2000	—
		295	—	400	2000	—
		395	—	500	2000	—
		495	—	600	1780	—
		595	—	700	1270	—
		190	220	340	1000	1000
	20	290	320	440	1000	1000
		390	420	540	1000	1000
		490	520	640	1000	910
		590	620	740	730	660
		690	720	840	550	500
		790	820	940	430	400
20	190	220	340	2000	2000	
	290	320	440	2000	2000	
	390	420	540	2000	2000	
	490	520	640	1980	1770	
	590	620	740	1430	1300	
	690	720	840	1080	990	
790	820	940	840	780		

*Indicates a stroke when one inner block is incorporated.

Note1) The maximum speed is the value restricted by the permissible rotation speed of the Ball Screw or the permissible speed of the guide, with the motor rotating at 6,000 min⁻¹.

Note2) When considering the use of this model at speed higher than the maximum speed indicated above, contact THK.

Model No.	Ball screw lead (mm)	Stroke* (mm)		Outer rail length (mm)	Maximum speed (mm/s)	
		Long type block	Short type block		Long type block	Short type block
SKR55	20	800	—	980	1100	—
		900		1080	880	
		1000		1180	730	
		1100		1280	610	
		1200		1380	520	
	30	800		980	1650	
		900		1080	1330	
		1000		1180	1100	
		1100		1280	920	
		1200		1380	780	
	40	800		980	2160	
		900		1080	1750	
		1000		1180	1440	
		1100		1280	1210	
		1200		1380	1030	
SKR65	20	790	980	1470	—	
		990	1180	970		
		1190	1380	690		
		1490	1680	450		
	25	790	980	1810		
		990	1180	1200		
		1190	1380	850		
		1490	1680	550		
	30	790	980	2210		
		990	1180	1460		
		1190	1380	1030		
		1490	1680	670		
	50	790	980	3000		
		990	1180	2350		
		1190	1380	1680		
1490		1680	1100			

*Indicates a stroke when one inner block is incorporated.

Note1) The maximum speed is restricted by the permissible rotation speed of the ball screw, the permissible speed of the guide or 6,000 min⁻¹ of motor speed.

Note2) When considering the use of this model at speed higher than the maximum speed indicated above, contact THK.

Lubrication

Table7 shows standard greases used in model SKR and grease nipple types.

Table7 Types of standard grease and grease nipples used

Model No.	Standard grease	Grease nipple used
SKR20	THK AFA Grease	PB107
SKR26	THK AFA Grease	PB107
SKR33	THK AFB-LF Grease	PB107
SKR46	THK AFB-LF Grease	A-M6F
SKR55	THK AFB-LF Grease	A-M6F
SKR65	THK AFB-LF Grease	A-M6F

Static Safety Factor

Caged Ball LM Guide Actuator Model SKR consists of an LM Guide, a Ball Screw and a support bearing. The static safety factor and the service life of each component can be obtained from the basic load rating indicated in "Rated load of model SKR" (see Table 4-12).

[Calculating the Static Safety Factor]

● LM Guide Unit

To calculate a load applied to the LM Guide of model SKR, the average load required for calculating the service life and the maximum load needed for calculating the static safety factor must be obtained first. In particular, if the system starts and stops frequently, or if a large moment caused by an overhung load is applied to the system, it may receive an unexpectedly large load.

When selecting a model number, make sure that the desired model is capable of receiving the required maximum load (whether stationary or in motion).

$$f_s = \frac{C_0}{P_{\max}}$$

f_s : Static safety factor

C_0 : Basic static load rating (N)

P_{\max} : Maximum applied load (N)

*The basic static load rating is a static load with a constant direction and magnitude whereby the sum of the permanent deformation of the rolling element and that of the raceway on the contact area under the maximum stress is 0.0001 times the rolling element diameter.

● Ball Screw Unit/Bearing Unit(Fixed Side)

If an unexpected external force is applied in the axial direction as a result of an inertia caused by an impact or start and stop while model SKR is stationary or operating, it is necessary to take into account the static safety factor.

$$f_s = \frac{C_{0a}}{F_{\max}}$$

f_s : Static safety factor

C_{0a} : Basic static load rating (N)

F_{\max} : Maximum applied load (N)

[Standard Values for the Static Safety Factor (f_s)]

Machine type	Load conditions	Minimum Static Safety Factor (f_s)
General industrial machinery	Without vibration or impact	1.0 to 3.5
	With vibration or impact	2.0 to 5.0

*The standard value of the static safety factor may vary depending on the load conditions as well as environment, lubrication status, mounting accuracy, and/or rigidity.

Service Life

[LM Guide Unit]

● Nominal Life

The nominal life means the total travel distance that 90% of a group of units of the same LM Guide model can achieve without flaking (scale-like pieces on the metal surface) after individually running under the same conditions.

The nominal life of the LM Guide is obtained using the following formula.

■ Calculating the Nominal Life

The nominal life (L_{10}) of an LM Guide with balls is obtained from the following formula using the basic dynamic load rating (C), which is based on a reference distance of 50 km, and the calculated load acting on the LM Guide (P_c).

- LM Guide with balls (Using a basic dynamic load rating based on a nominal life of 50 km)

$$L_{10} = \left(\frac{C}{P_c} \right)^3 \times 50 \dots\dots\dots(1)$$

L_{10}	: Nominal life	(km)
C	: Basic dynamic load rating	(N)
P_c	: Calculated load	(N)

*This nominal life formula may not apply if the length of the stroke is less than or equal to twice the length of the LM block.

When comparing the nominal life (L_{10}), you must take into account whether the basic dynamic load rating was defined based on 50 km or 100 km. Convert the basic dynamic load rating based on ISO 14728-1 as necessary.

ISO-regulated basic dynamic load rating conversion formula:

- LM Guide with balls

$$C_{100} = \frac{C_{50}}{1.26}$$

C_{50}	: Basic dynamic load rating based on a nominal life of 50 km
C_{100}	: Basic dynamic load rating based on a nominal life of 100 km

■ Calculating the Modified Nominal Life

During use, an LM Guide may be subjected to vibrations and shocks as well as fluctuating loads, which are difficult to detect. In addition, having LM blocks arranged directly behind one another will have a decisive impact on the service life. Taking these factors into account, the modified nominal life (L_{10m}) can be calculated according to the following formula (2).

● Modified factor α

$$\alpha = \frac{f_c}{f_w}$$

α	: Modified factor
f_c	: Contact factor (see Table9 on A2-23)
f_w	: Load factor (see Table8 on A2-22)

● Modified nominal life L_{10m}

- LM Guide with balls

$$L_{10m} = \left(\alpha \times \frac{C}{P_c} \right)^3 \times 50 \dots\dots\dots(2)$$

L_{10m}	: Modified nominal life	(km)
C	: Basic dynamic load rating	(N)
P_c	: Calculated load	(N)

- If a moment is applied, calculate the equivalent load by multiplying the applied moment by the equivalent factor indicated in Table 10 on **A2-23**.

$$P_m = K \cdot M$$

P_m : Equivalent load (per inner block) (N)

K : Equivalent moment factor

M : Applied moment (N·mm)

(If planning to use the product with a wide inner block span, contact THK.)

If moment M_c is applied to model SKR-B/D

$$P_m = \frac{K_c \cdot M_c}{2}$$

- If a radial load (P) and a moment are simultaneously applied to model SKR

$$P_E = P_m + P$$

P_E : Overall equivalent radial load (N)

Perform a nominal life calculation using the above data.

● Service Life Time

When the nominal life (L_{10}) has been obtained, the service life time is obtained using the following equation (if the stroke length and the number of reciprocations per minute are constant).

$$L_h = \frac{L_{10} \times 10^6}{2 \cdot \ell_s \cdot n_1 \times 60}$$

L_h : Service life time

(h) n_1 : Number of reciprocations per minute (min^{-1})

ℓ_s : Stroke length

(mm)

[Ball Screw Unit/Bearing Unit(Fixed Side)]

● Nominal Life

The nominal life (L_{10}) means the total travel distance that 90% of a group of units of the same ball screw (bearing) can achieve without flaking after individually running under the same conditions.

The nominal life of the ball screw unit/bearing unit (fixed side) is obtained using the following equation.

■ Calculating the Nominal Life

The nominal life (L_{10}) is obtained from the following equation using the basic dynamic load rating (C_a) and the load acting on the ball screw in the axial direction (F_a).

$$L_{10} = \left(\frac{C_a}{F_a} \right)^3 \times 10^6 \dots\dots\dots(1)$$

L_{10} : Nominal life (rev.)

C_a : Basic dynamic load rating (N)

F_a : Axial load (N)

■ Calculating the Modified Nominal Life

During use, a ball screw may be subjected to vibrations and shocks as well as fluctuating loads, which are difficult to detect. Taking these factors into account, the modified nominal life (L_{10m}) can be calculated according to the following formula (2).

- Modified factor α

$$\alpha = \frac{1}{f_w}$$

α : Modified factor

f_w : Load factor

(see Table8)

- Modified nominal life L_{10m}

$$L_{10m} = \left(\alpha \times \frac{C_a}{F_a} \right)^3 \times 10^6 \dots\dots\dots (2)$$

L_{10m} : Modified nominal life

(rev.)

α : Modified factor

C_a : Basic dynamic load rating

(N)

F_a : Axial load

(N)

Table8 Load Factor (f_w)

Vibrations/impact	Speed(V)	f_w
Faint	Very low $V \leq 0.25\text{m/s}$	1 to 1.2
Weak	Slow $0.25\text{m/s} < V \leq 1\text{m/s}$	1.2 to 1.5
Medium	Medium $1\text{m/s} < V \leq 2\text{m/s}$	1.5 to 2
Strong	High $V > 2\text{m/s}$	2 to 3.5

● Service Life Time

When the nominal life (L_{10}) has been obtained, the service life time is obtained using the following equation (if the stroke length and the number of reciprocations per minute are constant).

$$L_h = \frac{L_{10} \cdot \ell}{2 \cdot \ell_s \cdot n_1 \times 60}$$

L_h : Service life time (h) n_1 : Number of reciprocations per minute (min⁻¹)
 ℓ_s : Stroke length (mm) ℓ : Ball screw lead (mm)

■fc: Contact Factor

If two inner blocks are used in close contact with each other with model SKR-B/D, multiply the basic load rating by the corresponding contact factor indicated in Table9.

Table9 Contact Factor (f_c)

Block type	Contact factor f_c
Model SKR-B Model SKR-D	0.81

■fw: Load Factor

In general, machines in reciprocal motion are likely to cause vibration and impact during operation, and it is particularly difficult to accurately determine each of vibration generated during high-speed operation, impact applied during repeated starting and stopping in normal use, etc. Therefore, where the effect of speed vibration is estimated to be significant, divide the basic load rating (C) by an empirically obtained load factor.

■K: Moment Equivalent Factor (LM Guide Unit)

When model SKR travels under a moment, the distribution of load applied to the LM Guide is locally large. In such cases, calculate the load by multiplying the moment value by the corresponding moment equivalent factor indicated in Table10.

Symbols K_A , K_B and K_C indicate the moment equivalent loads in the M_A , M_B and M_C directions, respectively.

Table10 Equivalent moment factor(K)

Model No.	K_A	K_B	K_C
SKR20-A	2.34×10^{-1}	2.34×10^{-1}	8.07×10^{-2}
SKR20-B	4.38×10^{-2}	4.38×10^{-2}	8.07×10^{-2}
SKR26-A	1.59×10^{-1}	1.59×10^{-1}	6.17×10^{-2}
SKR26-B	3.18×10^{-2}	3.18×10^{-2}	6.17×10^{-2}
SKR33-A	1.42×10^{-1}	1.42×10^{-1}	5.05×10^{-2}
SKR33-B	2.47×10^{-2}	2.47×10^{-2}	5.05×10^{-2}
SKR33-C	2.39×10^{-1}	2.39×10^{-1}	5.05×10^{-2}
SKR33-D	3.54×10^{-2}	3.54×10^{-2}	5.05×10^{-2}
SKR46-A	9.51×10^{-2}	9.51×10^{-2}	3.46×10^{-2}
SKR46-B	1.70×10^{-2}	1.70×10^{-2}	3.46×10^{-2}
SKR46-C	1.46×10^{-1}	1.46×10^{-1}	3.46×10^{-2}
SKR46-D	2.36×10^{-2}	2.36×10^{-2}	3.46×10^{-2}
SKR55-A	8.12×10^{-2}	8.12×10^{-2}	2.88×10^{-2}
SKR55-B	1.46×10^{-2}	1.46×10^{-2}	2.88×10^{-2}
SKR65-A	7.16×10^{-2}	7.16×10^{-2}	2.21×10^{-2}
SKR65-B	1.27×10^{-2}	1.27×10^{-2}	2.21×10^{-2}

K_A : Moment equivalent factor in the M_A direction.

K_B : Moment equivalent factor in the M_B direction.

K_C : Moment equivalent factor in the M_C direction.

Note) The values for models SKR-B/D indicate the values when double inner blocks are used in close contact with each other.

Accuracy Standards

The accuracy standard of model SKR is defined in positioning repeatability, positioning accuracy, running parallelism (vertical direction) and backlash.

[Positioning Repeatability]

Command the position to a given arbitrary point. Measure the position and repeat seven times from the same direction. Record the difference between the largest and smallest values. Conduct the same test at three points: the middle of the stroke, and at both the approximate maximum and minimum positions of travel. Express the maximum difference value of the three measurements divided by 2 with a "±" sign.

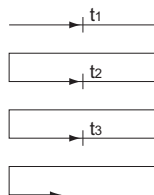

Fig.8 Positioning Repeatability

[Positioning Accuracy]

Using the maximum stroke as the reference length, express the maximum error between the actual distance traveled from the reference point and the command value in an absolute value as positioning accuracy.

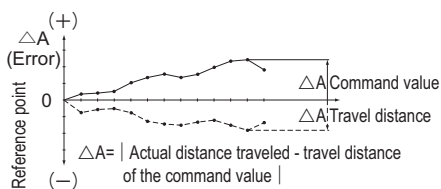

Fig.9 Positioning Accuracy

[Running of Parallelism (Vertical direction)]

Place a straightedge on the surface table where model SKR is mounted, measure almost throughout the travel distance of the inner block using a test indicator. Use the maximum difference among the readings within the travel distance as the running parallelism measurement.

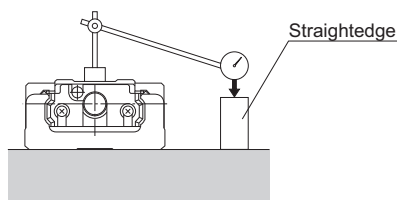

Fig.10 Running of Parallelism

[Backlash]

Feed and slightly move the inner block and read the measurement on the test indicator as the reference value. Subsequently, apply a load from the same direction (table feed direction), and then release the inner block from the load. Use the difference between the reference value and the return as the backlash measurement.

Perform this measurement in the center and near both ends, and use the maximum value as the measurement value.

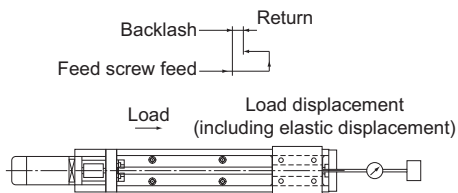

Fig.11 Backlash

The accuracies of model SKR are classified into normal grade (no symbol), high accuracy grade (H) and precision grade (P). Tables below show standards for all the accuracies.

Table11 Normal Grade (No Symbol)

Unit: mm

Model No.	Stroke	Outer rail length	Positioning Repeatability	Positioning Accuracy	Running Parallelism (Vertical Direction)	Backlash	Starting torque (N·cm)
SKR20	30	100	±0.01	No standard defined	No standard defined	0.02	0.5
	80	150					
	130	200					
SKR26	60	150	±0.01	No standard defined	No standard defined	0.02	1.5
	110	200					
	160	250					
	210	300					
SKR33	45	150	±0.01	No standard defined	No standard defined	0.02	7
	95	200					
	195	300					
	295	400					
	395	500					
	495	600					
SKR46	595	700	±0.01	No standard defined	No standard defined	0.02	10
	190	340					
	290	440					
	390	540					
	490	640					
	590	740					
	690	840					
SKR55	790	940	±0.01	No standard defined	No standard defined	0.05	12
	800	980					
	900	1080					
	1000	1180					
	1100	1280					
SKR65	1200	1380	±0.01	No standard defined	No standard defined	0.05	12
	790	980					
	990	1180					
	1190	1380					
	1490	1680	±0.012				15

*Indicates stroke length when one long-type inner block is incorporated.

Note1) The evaluation method for accuracy standards complies with THK standards.

Note2) Measurements are taken while using a motor provided by THK. For motor-wrap configurations, these values may not apply.

Note3) The starting torque represents the value when the following grease is used.

Models SKR20 and SKR26: THK AFA Grease

Models SKR33, SKR46, SKR55 and SKR65: THK AFB-LF Grease

Note4) If highly viscous grease such as vacuum grease and clean room grease is used, the actual starting torque may exceed the corresponding value in the table. Use great care in selecting a motor.

Note5) Contact THK for accuracy information of units longer than the standard length.

Table12 High Accuracy Grade (H)

Unit: mm

Model No.	Stroke*	Outer rail length	Positioning Repeatability	Positioning Accuracy	Running of Parallelism (Vertical direction)	Backlash	Starting torque (N·cm)
SKR20	30	100	±0.005	0.06	0.025	0.01	0.5
	80	150					
	130	200					
SKR26	60	150	±0.005	0.06	0.025	0.01	1.5
	110	200					
	160	250					
	210	300					
SKR33	45	150	±0.005	0.06	0.025	0.02	7
	95	200					
	195	300					
	295	400		0.10	0.035		
	395	500					
	495	600					
595	700	0.12	0.04				
SKR46	190	340	±0.005	0.10	0.035	0.02	10
	290	440					
	390	540					
	490	640		0.12	0.04		
	590	740					
	690	840					
	790	940					
SKR55	800	980	±0.005	0.18	0.05	0.05	12
	900	1080					
	1000	1180		0.25			
	1100	1280					
	1200	1380					
SKR65	790	980	±0.008	0.18	0.05	0.05	12
	990	1180		0.2			
	1190	1380					
	1490	1680		0.28			0.055

*Indicates stroke length when one long-type inner block is incorporated.

Note1) The evaluation method for accuracy standards complies with THK standards.

Note2) Measurements are taken while using a motor provided by THK. For motor-wrap configurations, these values may not apply.

Note3) The starting torque refers to the values when THK AFB-LF Grease is used. However, the values for SKR20/26 refer to the values when using THK AFA Grease.

Note4) If highly viscous grease such as vacuum grease and clean room grease is used, the actual starting torque may exceed the corresponding value in the table. Use great care in selecting a motor.

Note5) Contact THK for accuracy information of units longer than the standard length.

Table13 Precision Grade (P)

Unit: mm

Model No.	Stroke*	Outer rail length	Positioning Repeatability	Positioning Accuracy	Running of Parallelism (Vertical direction)	Backlash	Starting torque (N·cm)
SKR20	30	100	±0.003	0.02	0.01	0.003	1.2
	80	150					
	130	200					
SKR26	60	150	±0.003	0.02	0.01	0.003	4
	110	200					
	160	250					
	210	300					
SKR33	45	150	±0.003	0.02	0.01	0.003	15
	95	200					
	195	300		0.025	0.015		
	295	400					
	395	500		0.03	0.02		
	495	600					
595	700						
SKR46	190	340	±0.003	0.025	0.015	0.003	15
	290	440					
	390	540		0.03	0.02		17
	490	640					
	590	740					
	690	840					
790	940						
SKR55	800	980	±0.005	0.035	0.025	0.003	17
	900	1080		0.04	0.03		20
	1000	1180					
SKR65	790	980	±0.005	0.035	0.025	0.005	20
	990	1180		0.04	0.03		22
	1190	1380					

*Indicates stroke length when one long-type inner block is incorporated.

Note1) The evaluation method complies with THK standards.

Note2) Measurements are taken while using a motor provided by THK. For motor-wrap configurations, these values may not apply.

Note3) The starting torque represents the value when the following grease is used.

Models SKR20 and SKR26: THK AFA Grease

Models SKR33, SKR46, SKR55 and SKR65: THK AFB-LF Grease

Note4) If harder grease is used, such as vacuum/clean-room grease, the actual starting torque may exceed the values listed.

Note5) Contact THK for information on accuracy for lengths equal to or longer than the standard outer rail.

Model Number Coding

Model No.	Ball screw lead	Inner block type	QZ specification	Stroke	Accuracy grade
SKR33	10	A	QZ	0270	P
①	②	③	④	⑤	⑥

SKR20	01: 1 mm	A	No symbol : No QZ	0020: 20 mm	No symbol: Normal grade
SKR26	02: 2 mm	B	QZ	0030: 30 mm	H: High accuracy grade
SKR33	06: 6 mm	C	QZA	}	P: Precision grade
SKR46	10: 10 mm	D	QZB	1490: 1490 mm	
SKR55	20: 20 mm		QZAD		
SKR65	25: 25 mm				
	30: 30 mm				
	40: 40 mm				
	50: 50 mm				

QZ specification ④ can be selected on the following models.

SKR33 (→ **A2-38**)

SKR46 (→ **A2-46**)

*It cannot be selected for SKR20, SKR26, SKR55 and SKR65.

If QZ, QZA, QZB, or QZAD is selected for QZ specification ④, specify a stroke incorporating QZ. (→ **A2-65**)

If "2: with a bellows" has been selected for Cover ⑧, specify a stroke incorporating the bellows. (→ **A2-76**)

The available ball screw leads differ depending on the model.

SKR20: "01," "06"

SKR26: "02," "06"

SKR33: "06," "10," "20" (20 mm is available for inner block type A and B only)

SKR46: "10," "20"

SKR55: "20," "30," "40"

SKR65: "20," "25," "30," "50"

	With/without a motor		Cover	Sensor	Housing A/ Intermediate flange
	0	-	1	B	AQ
	⑦		⑧	⑨	⑩

With direct coupling
0: Direct coupling (without motor)
1: Direct coupling (THK will purchase and mount the motor you specify)
With motor wrap
R1: Non-standard side wrap (without motor)
R2: Standard side wrap (without motor)
R3: Bottom side wrap (without motor)
R4: Non-standard side wrap (THK will purchase and mount the motor you specify)
R5: Standard side wrap (THK will purchase and mount the motor you specify)
R6: Bottom side wrap (THK will purchase and mount the motor you specify)

0: Without cover
1: With cover
2: With bellows

0: None
1
2
6
7
B
E
H
L
J
M

With direct coupling	With motor wrap
A0	WN-05D
AN	WP-08D
AP	WP-08K
AQ	WP-08M
AR	WQ-08D
AS	WQ-08K
AT	WQ-08M
AU	WV-14M
AV	WY-11M
AY	WY-14M
AZ	WZ-16M
A5	WZ-19M
A6	W5-19M
20	
30	
40	
60	

If QZ specification ④ "QZ," "QZA," "QZB," or "QZAD" is selected, "2: With bellows" cannot be selected.

If "0" is selected:

No coupling will be attached. Please specify if a coupling is required when ordering.

If "R1," "R2," or "R3" is selected:

A timing pulley and timing belt will be included.

If "1," "R4," "R5," or "R6" is selected:

The designated motor will be mounted. Please specify the motor cable direction separately.

Please select an option for ⑩ Housing A/Intermediate flange that matches the specified motor.

This product is compatible with motors from various manufacturers. Contact THK for details.

⑦ Motor wrap direction

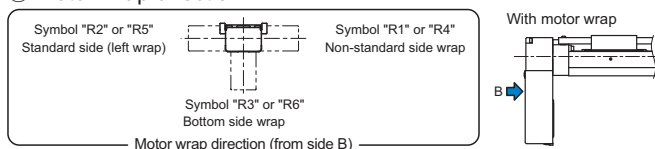

SKR20 Without Cover, Direct Motor Coupling

Model SKR20□□A (with a Single Long Nut Block)

Model SKR20□□B (with Two Long Nut Blocks)

For model number coding, see **A2-28**.

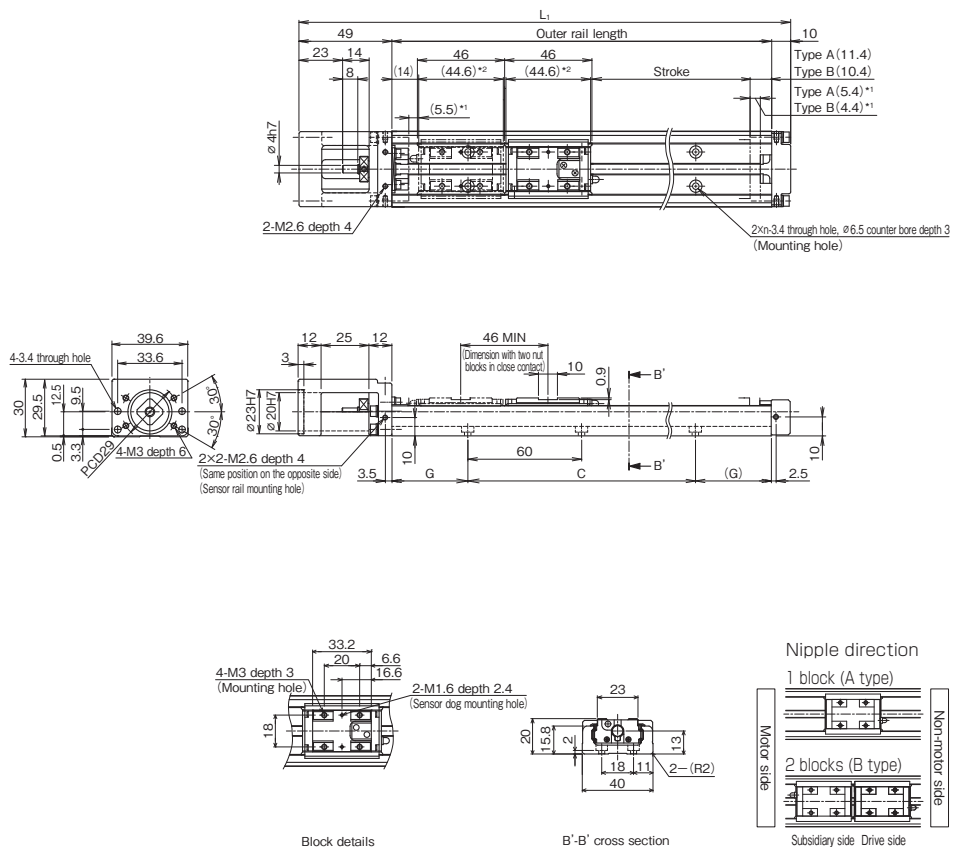

*1 Distance between the mechanical stopper and the stroke starting position.

*2 This indicates the block length when calculating the possible stroke range.

It is 90.6 mm (total) for an SKR20 with 2 blocks in close contact with each other (B type).

Stroke (mm) (stroke between mechanical stoppers)		Outer rail length (mm)	Overall length L_1 (mm)	C (mm)	G (mm)	n	Overall main unit mass (kg)	
Type A	Type B*						Type A	Type B
30 (40.9)	—	100	159	60	20	2	0.47	—
80 (90.9)	35 (44.9)	150	209	120	15	3	0.6	0.67
130 (140.9)	85 (94.9)	200	259	120	40	3	0.74	0.81

*Indicates a value when two inner blocks are in close contact with each other.

SKR20 With Cover, Direct Motor Coupling

Model SKR20□□A (with a Single Long Nut Block)

Model SKR20□□B (with Two Long Nut Blocks)

For model number coding, see **A2-28**.

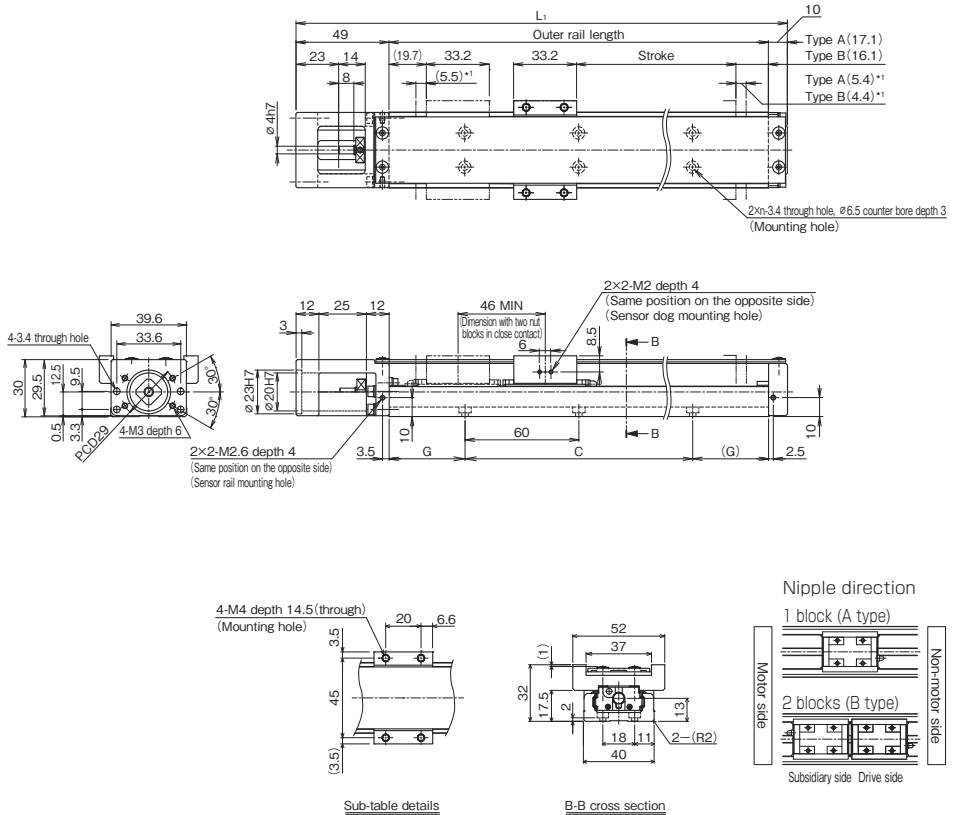

*1 Distance between the mechanical stopper and the stroke starting position.

Stroke (mm) (stroke between mechanical stoppers)		Outer rail length (mm)	Overall length L_1 (mm)	C (mm)	G (mm)	n	Overall main unit mass (kg)	
Type A	Type B						Type A	Type B
30 (40.9)	—	100	159	60	20	2	0.55	—
80 (90.9)	35 (44.9)	150	209	120	15	3	0.69	0.81
130 (140.9)	85 (94.9)	200	259	120	40	3	0.84	0.96

*Indicates a value when two inner blocks are in close contact with each other.

SKR20 Without Cover, Motor Wrap

Model SKR20□□A (with a Single Long Nut Block)

Model SKR20□□B (with Two Long Nut Blocks)

For model number coding, see **A2-28**.

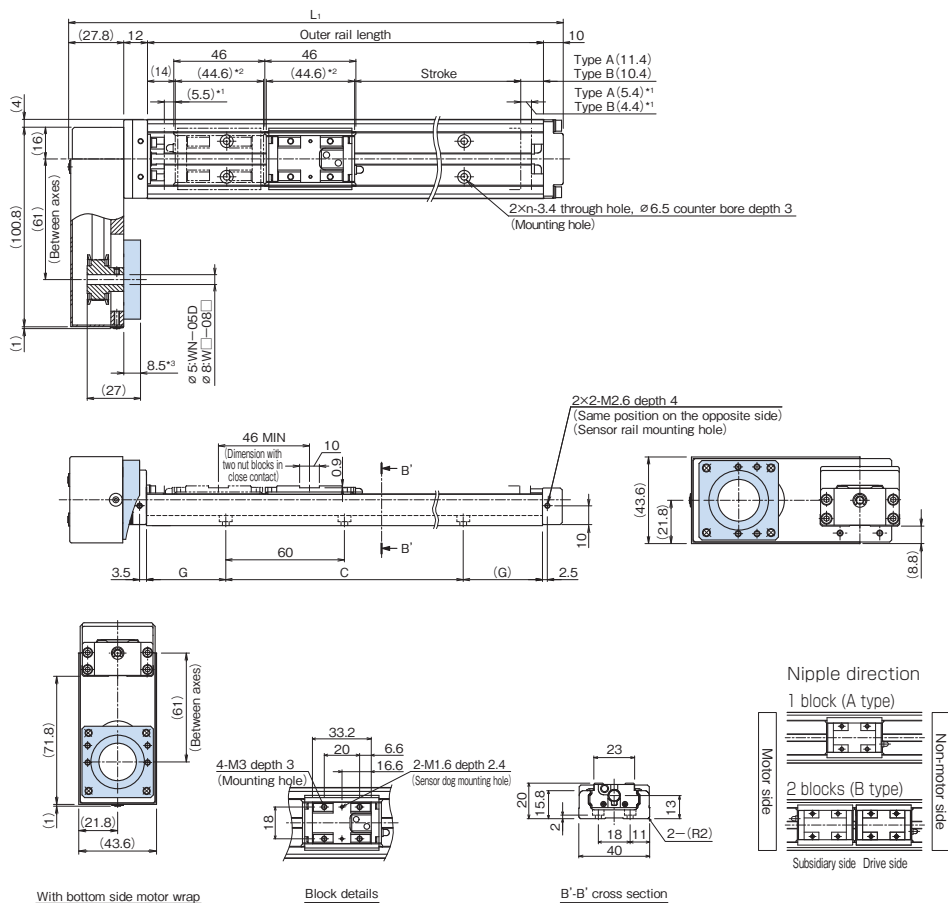

*1 Distance between the mechanical stopper and the stroke starting position.

*2 This indicates the block length when calculating the possible stroke range.

It is 90.6 mm (total) for an SKR20 with 2 blocks in close contact with each other (B type).

*3 Dimensions will vary if "WN" is selected for model number coding H Housing A/Intermediate flange. For details, see **A2-96**.

Stroke (mm) (stroke between mechanical stoppers)		Outer rail length (mm)	Overall length L_1 (mm)	C (mm)	G (mm)	n	Overall main unit mass (kg)	
Type A	Type B*						Type A	Type B
30 (40.9)	—	100	149.8	60	20	2	0.72	—
80 (90.9)	35 (44.9)	150	199.8	120	15	3	0.86	0.93
130 (140.9)	85 (94.9)	200	249.8	120	40	3	0.99	1.06

*Indicates a value when two inner blocks are in close contact with each other.

SKR20 With Cover, Motor Wrap

Model SKR20□□A (with a Single Long Nut Block)

Model SKR20□□B (with Two Long Nut Blocks)

For model number coding, see **A2-28**.

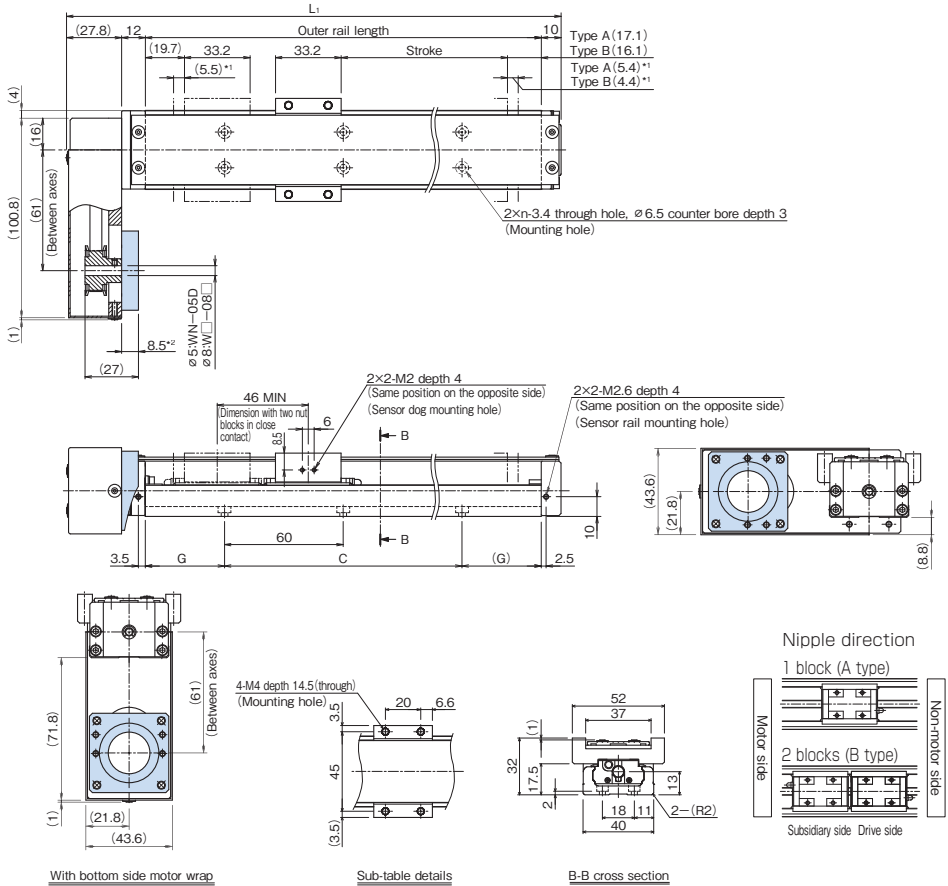

*1 Distance between the mechanical stopper and the stroke starting position.

*2 Dimensions will vary if "WN" is selected for model number coding (Housing A/Intermediate flange). For details, see **A2-96**.

Stroke (mm) (stroke between mechanical stoppers)		Outer rail length (mm)	Overall length L_1 (mm)	C (mm)	G (mm)	n	Overall main unit mass (kg)	
Type A	Type B						Type A	Type B
30 (40.9)	—	100	149.8	60	20	2	0.81	—
80 (90.9)	35 (44.9)	150	199.8	120	15	3	0.95	1.07
130 (140.9)	85 (94.9)	200	249.8	120	40	3	1.09	1.21

*Indicates a value when two inner blocks are in close contact with each other.

SKR26 Without Cover, Direct Motor Coupling

Model SKR26□□A (with a Single Long Nut Block)

Model SKR26□□B (with Two Long Nut Blocks)

For model number coding, see **A2-28**.

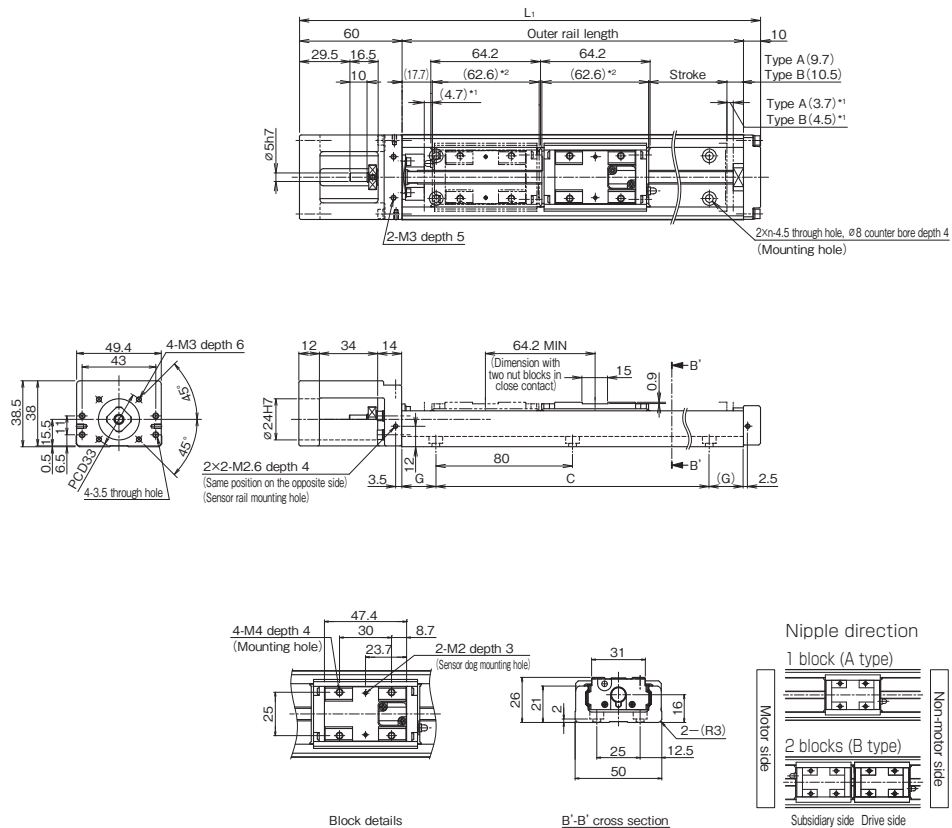

*1 Distance between the mechanical stopper and the stroke starting position.

*2 This indicates the block length when calculating the possible stroke range.

It is 126.8 mm (total) for an SKR26 with 2 blocks in close contact with each other (B type).

Stroke (mm) (stroke between mechanical stoppers)		Outer rail length (mm)	Overall length L ₁ (mm)	C (mm)	G (mm)	n	Overall main unit mass (kg)	
Type A	Type B*						Type A	Type B
60 (68.4)	—	150	220	80	35	2	1.01	—
110 (118.4)	45 (54.2)	200	270	160	20	3	1.22	1.39
160 (168.4)	95 (104.2)	250	320	160	45	3	1.43	1.6
210 (218.4)	145 (154.2)	300	370	240	30	4	1.64	1.81

*Indicates a value when two inner blocks are in close contact with each other.

SKR26 With Cover, Direct Motor Coupling

Model SKR26□□A (with a Single Long Nut Block)

Model SKR26□□B (with Two Long Nut Blocks)

For model number coding, see **A2-28**.

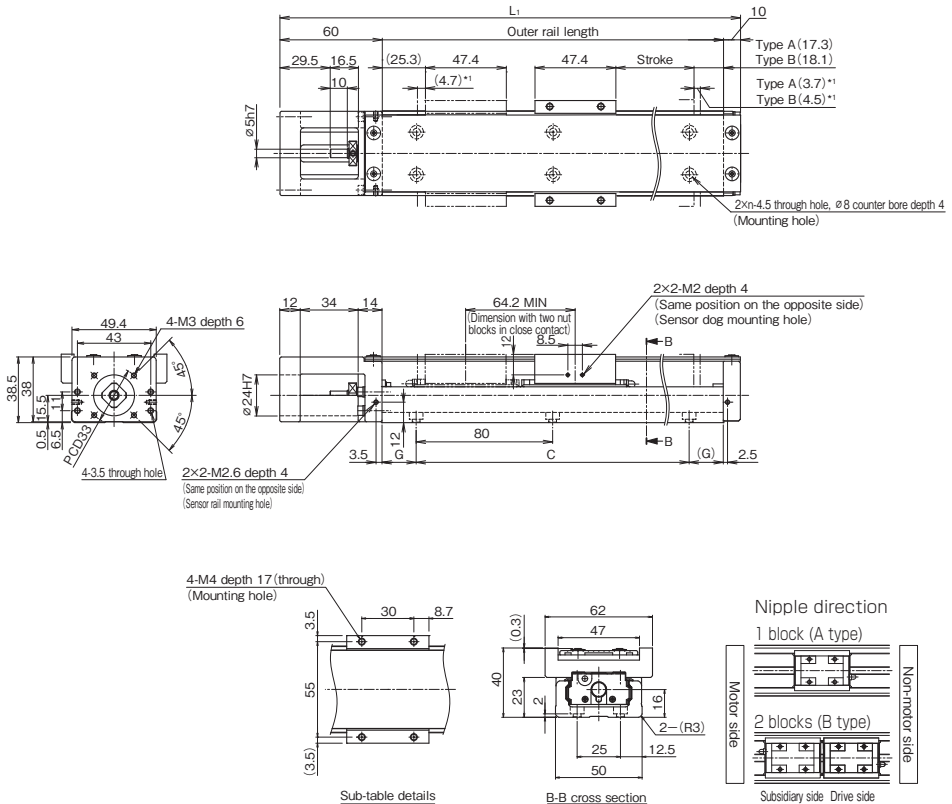

*1 Distance between the mechanical stopper and the stroke starting position.

Stroke (mm) (stroke between mechanical stoppers)		Outer rail length (mm)	Overall length L_1 (mm)	C (mm)	G (mm)	n	Overall main unit mass (kg)	
Type A	Type B*						Type A	Type B
60 (68.4)	—	150	220	80	35	2	1.17	—
110 (118.4)	45 (54.2)	200	270	160	20	3	1.39	1.64
160 (168.4)	95 (104.2)	250	320	160	45	3	1.61	1.86
210 (218.4)	145 (154.2)	300	370	240	30	4	1.83	2.08

*Indicates a value when two inner blocks are in close contact with each other.

SKR26 Without Cover, Motor Wrap

Model SKR26□□A (with a Single Long Nut Block)

Model SKR26□□B (with Two Long Nut Blocks)

For model number coding, see **A2-28**.

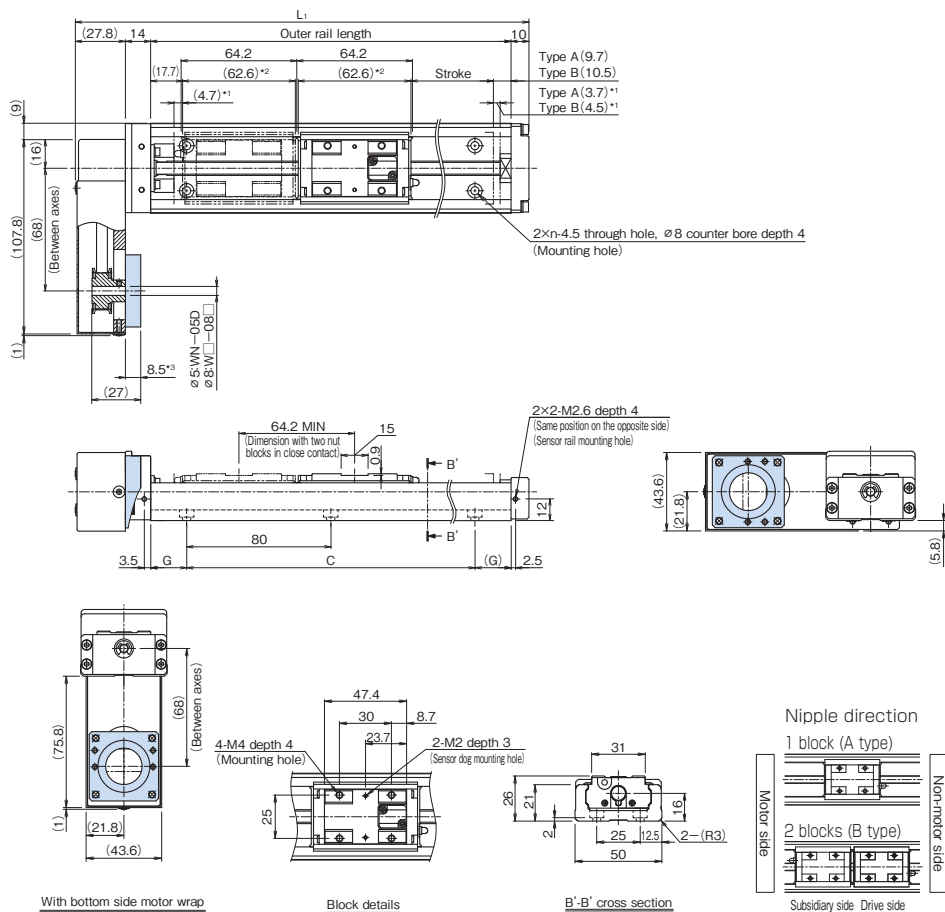

With bottom side motor wrap

Block details

B'-B' cross section

Subsidiary side Drive side

*1 Distance between the mechanical stopper and the stroke starting position.

*2 This indicates the block length when calculating the possible stroke range.

It is 128.8 mm (total) for an SKR26 with 2 blocks in close contact with each other (B type).

*3 Dimensions will vary if "WN" is selected for model number coding @ Housing A/Intermediate flange. For details, see **A2-99**.

Stroke (mm) (stroke between mechanical stoppers)		Outer rail length (mm)	Overall length L ₁ (mm)	C (mm)	G (mm)	n	Overall main unit mass (kg)	
Type A	Type B*						Type A	Type B
60 (68.4)	—	150	201.8	80	35	2	1.24	—
110 (118.4)	45 (54.2)	200	251.8	160	20	3	1.45	1.62
160 (168.4)	95 (104.2)	250	301.8	160	45	3	1.66	1.83
210 (218.4)	145 (154.2)	300	351.8	240	30	4	1.87	2.04

*Indicates a value when two inner blocks are in close contact with each other.

SKR26 With Cover, Motor Wrap

Model SKR26□□A (with a Single Long Nut Block)

Model SKR26□□B (with Two Long Nut Blocks)

For model number coding, see **A2-28**.

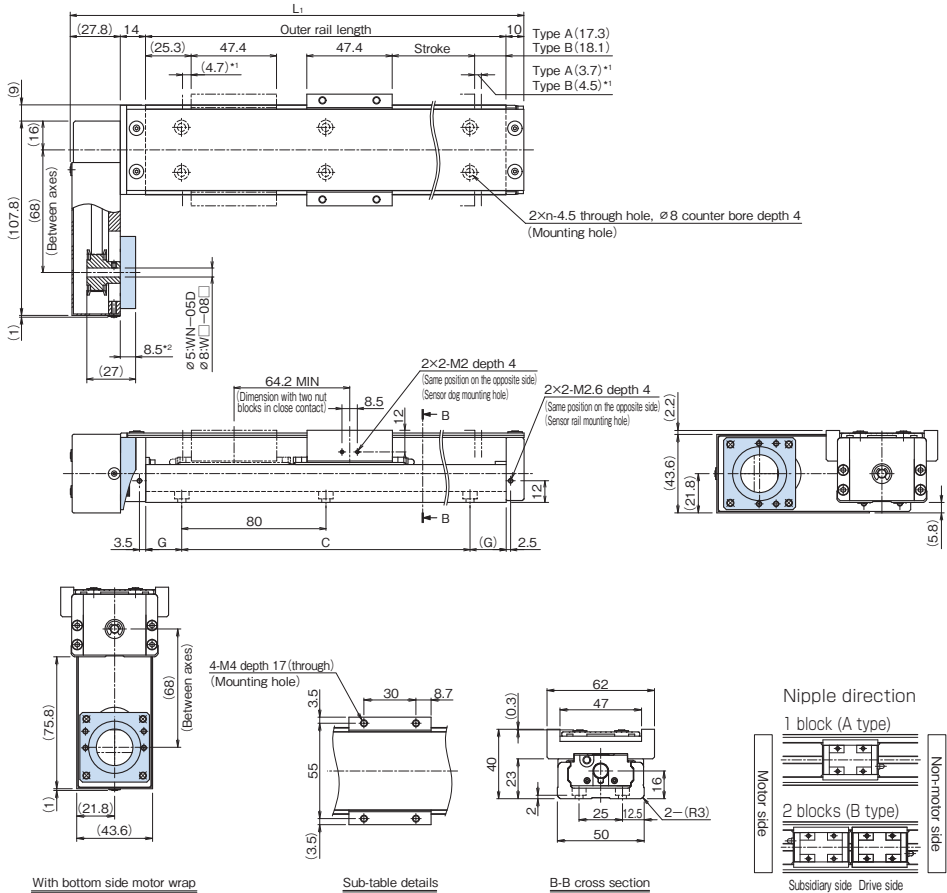

With bottom side motor wrap

Sub-table details

B-B cross section

Subsidiary side Drive side

*1 Distance between the mechanical stopper and the stroke starting position.

*2 Dimensions will vary if "WN" is selected for model number coding @ Housing A/Intermediate flange. For details, see **A2-99**.

Stroke (mm) (stroke between mechanical stoppers)		Outer rail length (mm)	Overall length L_1 (mm)	C (mm)	G (mm)	n	Overall main unit mass (kg)	
Type A	Type B*						Type A	Type B
60 (68.4)	—	150	201.8	80	35	2	1.39	—
110 (118.4)	45 (54.2)	200	251.8	160	20	3	1.61	1.86
160 (168.4)	95 (104.2)	250	301.8	160	45	3	1.84	2.09
210 (218.4)	145 (154.2)	300	351.8	240	30	4	2.06	2.31

*Indicates a value when two inner blocks are in close contact with each other.

SKR33 Without Cover, Direct Motor Coupling

Model SKR33□□A (with a Single Long Nut Block)

Model SKR33□□B (with Two Long Nut Blocks)

For model number coding, see **A2-28**.

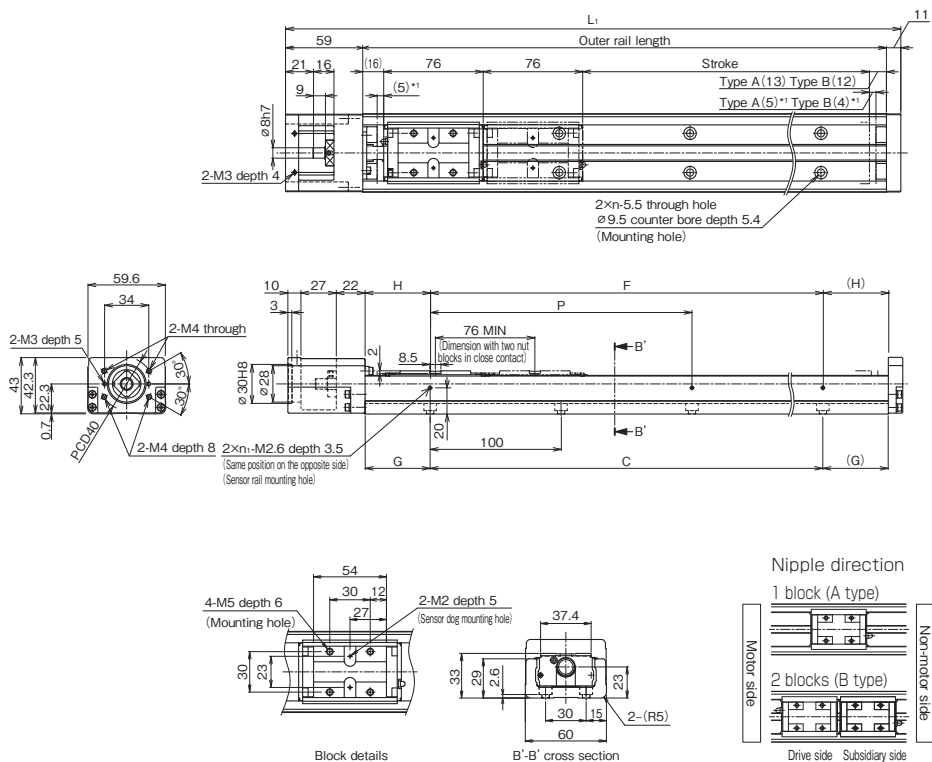

**1 Distance between the mechanical stopper and the stroke starting position.

Stroke (mm) (stroke between mechanical stoppers)		Outer rail length (mm)	Overall length L_1 (mm)	C (mm)	G (mm)	P (mm)	F (mm)	H (mm)	n	n_1	Overall main unit mass (kg)	
Type A	Type B										Type A	Type B
45 (55)	—	150	220	100	25	100	100	25	2	2	1.9	—
95 (105)	—	200	270	100	50	100	100	50	2	2	2.3	—
195 (205)	120 (129)	300	370	200	50	200	200	50	3	2	3	3.4
295 (305)	220 (229)	400	470	300	50	200	200	100	4	2	3.7	4.1
395 (405)	320 (329)	500	570	400	50	200	400	50	5	3	4.5	4.9
495 (505)	420 (429)	600	670	500	50	200	400	100	6	3	5.2	5.6
595 (605)	520 (529)	700	770	600	50	200	600	50	7	4	5.9	6.3

*Indicates a value when two inner blocks are in close contact with each other.

SKR33 With Cover, Direct Motor Coupling

Model SKR33□□A (with a Single Long Nut Block)

Model SKR33□□B (with Two Long Nut Blocks)

For model number coding, see **A2-28**.

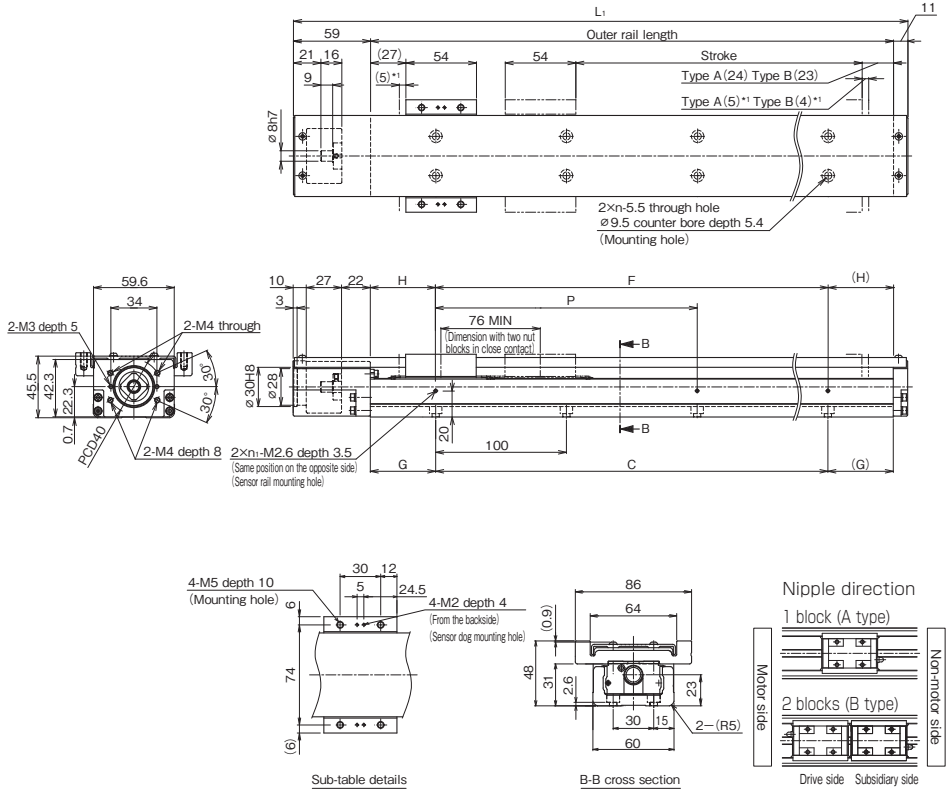

**1 Distance between the mechanical stopper and the stroke starting position.

Stroke (mm) (stroke between mechanical stoppers)		Outer rail length (mm)	Overall length L_1 (mm)	C (mm)	G (mm)	P (mm)	F (mm)	H (mm)	n	n_1	Overall main unit mass (kg)	
Type A	Type B*										Type A	Type B
45 (55)	—	150	220	100	25	100	100	25	2	2	2.3	—
95 (105)	—	200	270	100	50	100	100	50	2	2	2.6	—
195 (205)	120 (129)	300	370	200	50	200	200	50	3	2	3.4	4
295 (305)	220 (229)	400	470	300	50	200	200	100	4	2	4.2	4.8
395 (405)	320 (329)	500	570	400	50	200	400	50	5	3	4.9	5.5
495 (505)	420 (429)	600	670	500	50	200	400	100	6	3	5.7	6.3
595 (605)	520 (529)	700	770	600	50	200	600	50	7	4	6.4	7

*Indicates a value when two inner blocks are in close contact with each other.

SKR33 Without Cover, Motor Wrap

Model SKR33□□A (with a Single Long Nut Block)

Model SKR33□□B (with Two Long Nut Blocks)

For model number coding, see **A2-28**.

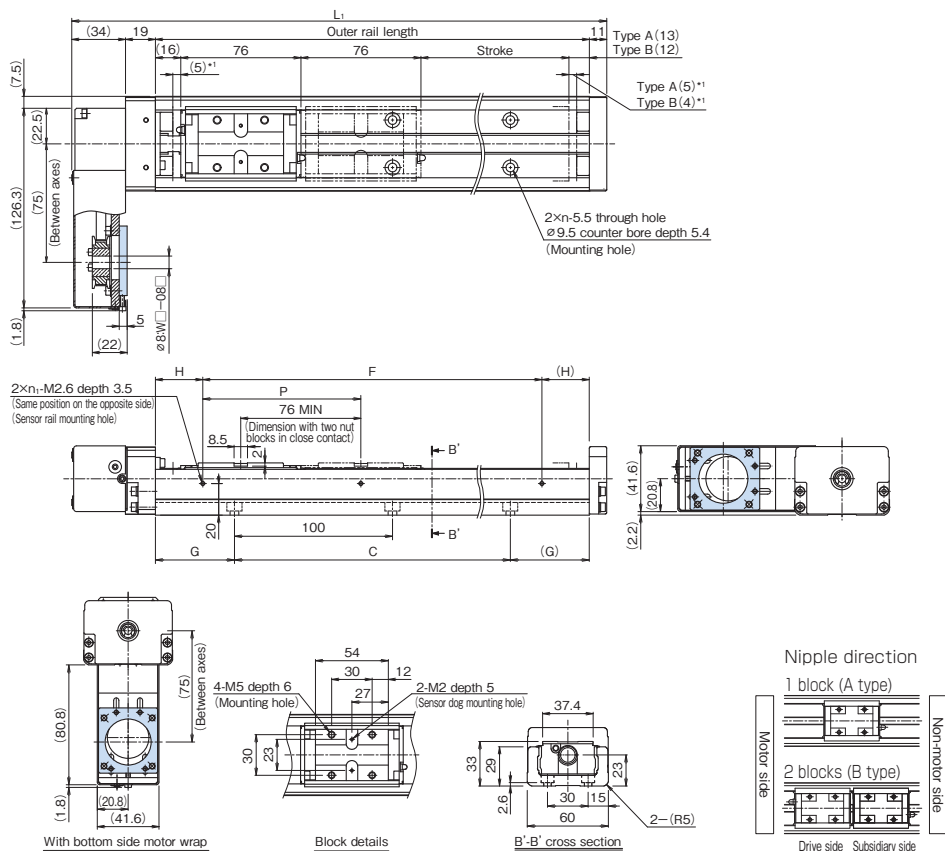

*1 Distance between the mechanical stopper and the stroke starting position.

Stroke (mm) (stroke between mechanical stoppers)		Outer rail length (mm)	Overall length L ₁ (mm)	C (mm)	G (mm)	P (mm)	F (mm)	H (mm)	n	n ₁	Overall main unit mass (kg)	
Type A	Type B										Type A	Type B
45 (55)	—	150	214	100	25	100	100	25	2	2	2.2	—
95 (105)	—	200	264	100	50	100	100	50	2	2	2.6	—
195 (205)	120 (129)	300	364	200	50	200	200	50	3	2	3.3	3.7
295 (305)	220 (229)	400	464	300	50	200	200	100	4	2	4	4.4
395 (405)	320 (329)	500	564	400	50	200	400	50	5	3	4.8	5.2
495 (505)	420 (429)	600	664	500	50	200	400	100	6	3	5.5	5.9
595 (605)	520 (529)	700	764	600	50	200	600	50	7	4	6.2	6.6

*Indicates a value when two inner blocks are in close contact with each other.

SKR33 With Cover, Motor Wrap

Model SKR33□□A (with a Single Long Nut Block)

Model SKR33□□B (with Two Long Nut Blocks)

For model number coding, see **A2-28**.

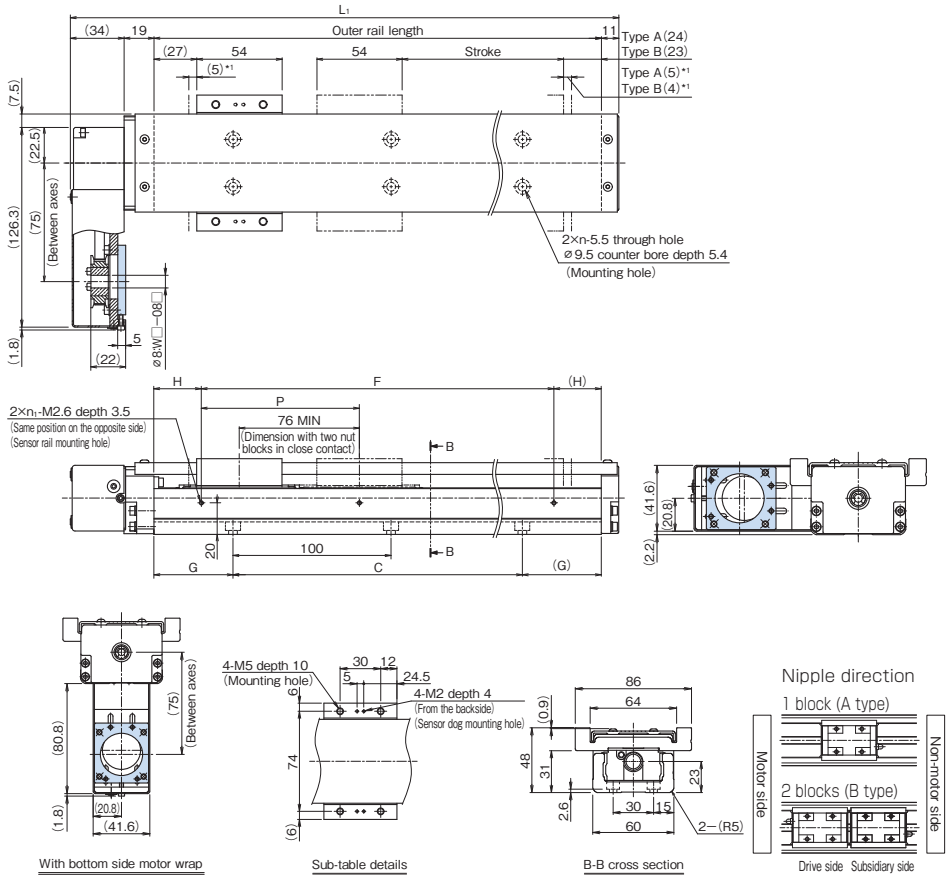

*1 Distance between the mechanical stopper and the stroke starting position.

Stroke (mm) (stroke between mechanical stoppers)		Outer rail length (mm)	Overall length L ₁ (mm)	C (mm)	G (mm)	P (mm)	F (mm)	H (mm)	n	n ₁	Overall main unit mass (kg)	
Type A	Type B*										Type A	Type B
45 (55)	—	150	214	100	25	100	100	25	2	2	2.5	—
95 (105)	—	200	264	100	50	100	100	50	2	2	2.9	—
195 (205)	120 (129)	300	364	200	50	200	200	50	3	2	3.7	4.3
295 (305)	220 (229)	400	464	300	50	200	200	100	4	2	4.4	5
395 (405)	320 (329)	500	564	400	50	200	400	50	5	3	5.2	5.8
495 (505)	420 (429)	600	664	500	50	200	400	100	6	3	6	6.6
595 (605)	520 (529)	700	764	600	50	200	600	50	7	4	6.7	7.3

*Indicates a value when two inner blocks are in close contact with each other.

Options⇒ **A2-65**

THK

A2-41

SKR33 Without Cover, Direct Motor Coupling

Model SKR33□□C (with a Single Short Nut Block)

Model SKR33□□D (with Two Short Nut Blocks)

For model number coding, see **A2-28**.

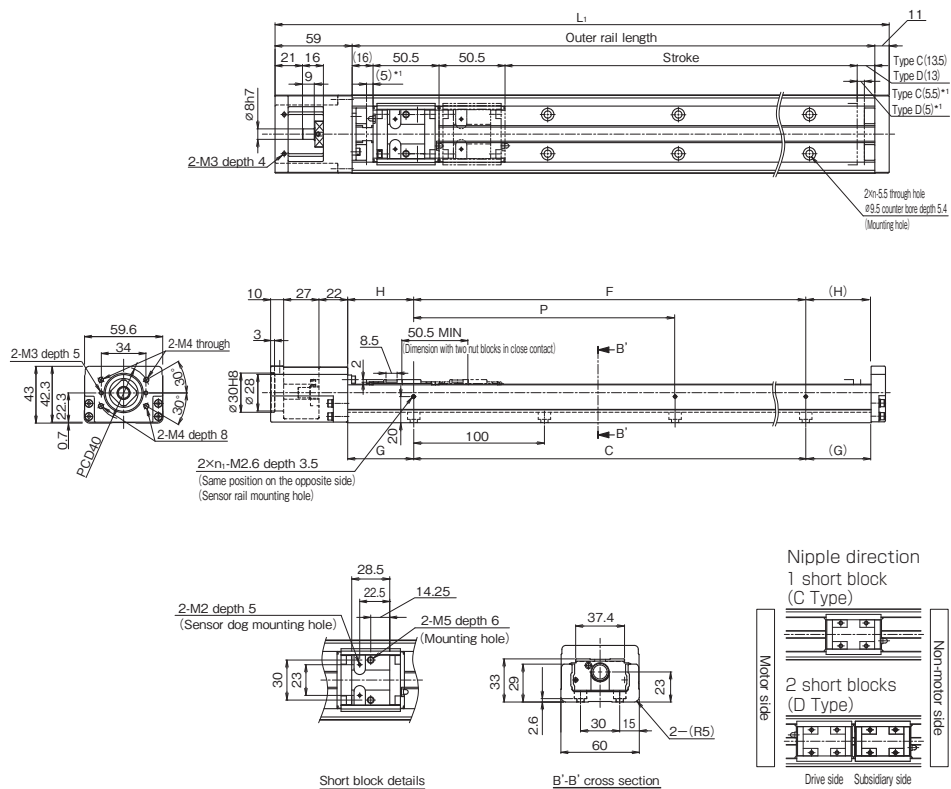

*1 Distance between the mechanical stopper and the stroke starting position.

Stroke (mm) (stroke between mechanical stoppers)		Outer rail length (mm)	Overall length L ₁ (mm)	C (mm)	G (mm)	P (mm)	F (mm)	H (mm)	n	n ₁	Overall main unit mass (kg)	
Type C	Type D										Type C	Type D
70 (80.5)	20 (30)	150	220	100	25	100	100	25	2	2	1.7	1.9
120 (130.5)	70 (80)	200	270	100	50	100	100	50	2	2	2.1	2.3
220 (230.5)	170 (180)	300	370	200	50	200	200	50	3	2	2.8	3
320 (330.5)	270 (280)	400	470	300	50	200	200	100	4	2	3.5	3.7
420 (430.5)	370 (380)	500	570	400	50	200	400	50	5	3	4.3	4.5
520 (530.5)	470 (480)	600	670	500	50	200	400	100	6	3	5	5.2
620 (630.5)	570 (580)	700	770	600	50	200	600	50	7	4	5.7	5.9

*Indicates a value when two inner blocks are in close contact with each other.

SKR33 With Cover, Direct Motor Coupling

Model SKR33□□C (with a Single Short Nut Block)

Model SKR33□□D (with Two Short Nut Blocks)

For model number coding, see **A2-28**.

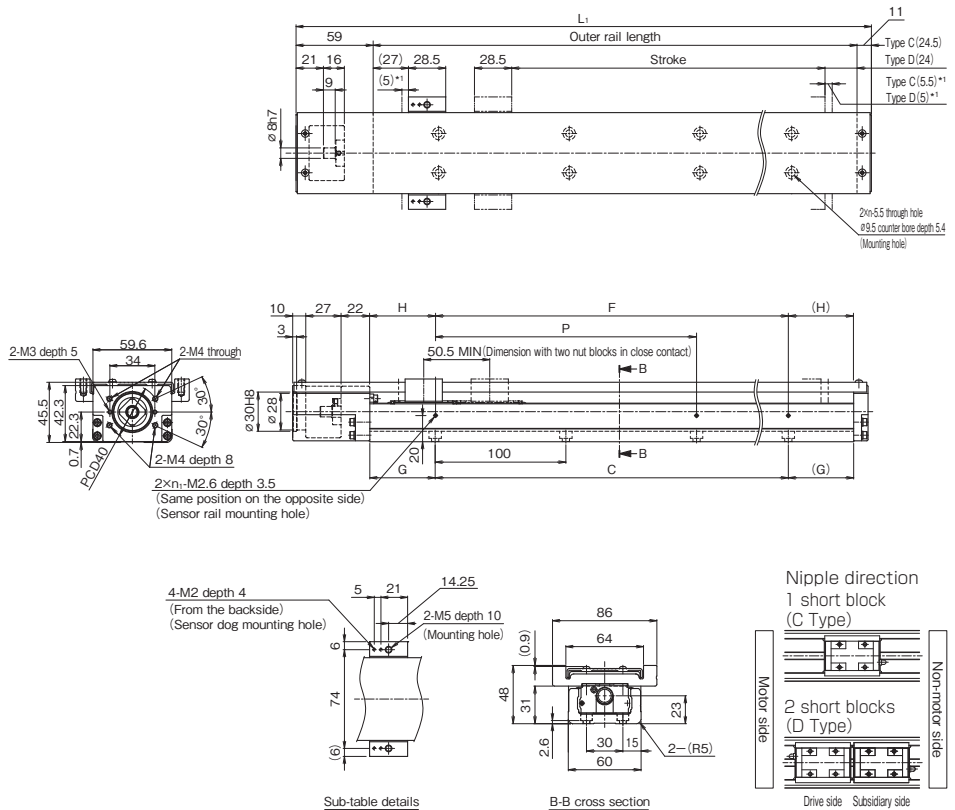

*1 Distance between the mechanical stopper and the stroke starting position.

Stroke (mm) (stroke between mechanical stoppers)		Outer rail length (mm)	Overall length L_1 (mm)	C (mm)	G (mm)	P (mm)	F (mm)	H (mm)	n	n_1	Overall main unit mass (kg)	
Type C	Type D										Type C	Type D
70 (80.5)	20 (30)	150	220	100	25	100	100	25	2	2	2	2.3
120 (130.5)	70 (80)	200	270	100	50	100	100	50	2	2	2.3	2.6
220 (230.5)	170 (180)	300	370	200	50	200	200	50	3	2	3.1	3.4
320 (330.5)	270 (280)	400	470	300	50	200	200	100	4	2	3.9	4.2
420 (430.5)	370 (380)	500	570	400	50	200	400	50	5	3	4.6	4.9
520 (530.5)	470 (480)	600	670	500	50	200	400	100	6	3	5.4	5.7
620 (630.5)	570 (580)	700	770	600	50	200	600	50	7	4	6.1	6.4

*Indicates a value when two inner blocks are in close contact with each other.

SKR33 Without Cover, Motor Wrap

Model SKR33□□C (with a Single Short Nut Block)

Model SKR33□□D (with Two Short Nut Blocks)

For model number coding, see **A2-28**.

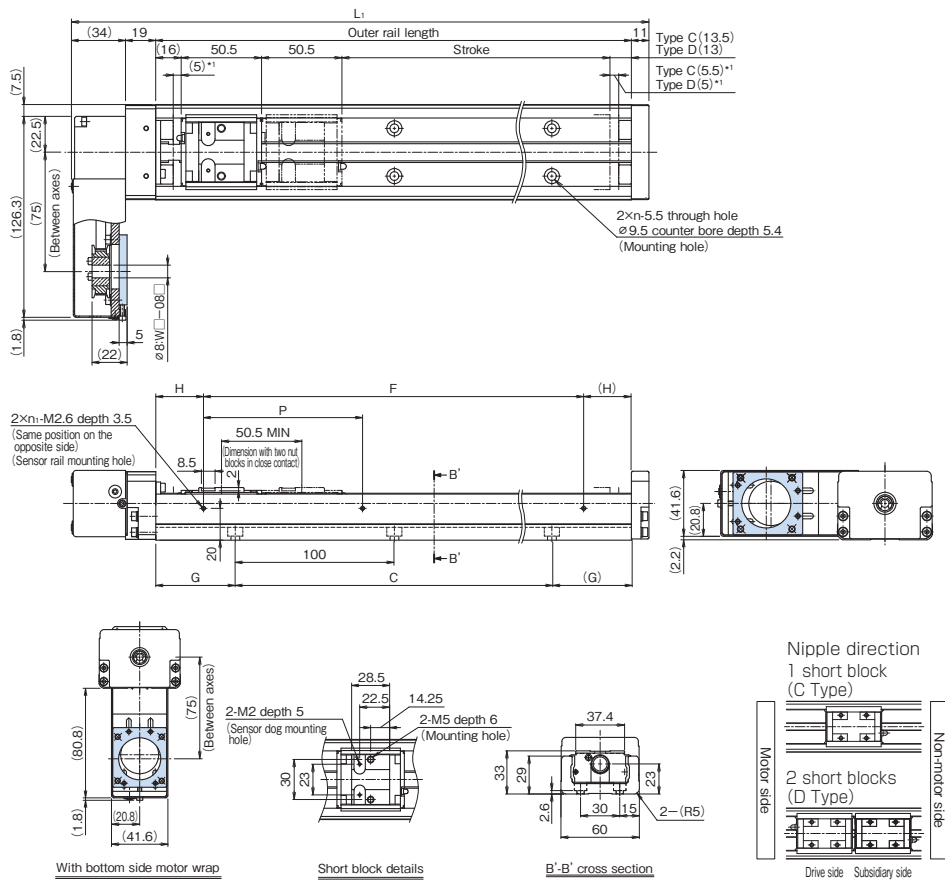

*1 Distance between the mechanical stopper and the stroke starting position.

Stroke (mm) (stroke between mechanical stoppers)		Outer rail length (mm)	Overall length L_1 (mm)	C (mm)	G (mm)	P (mm)	F (mm)	H (mm)	n	n_1	Overall main unit mass (kg)	
Type C	Type D										Type C	Type D
70 (80.5)	20 (30)	150	214	100	25	100	100	25	2	2	2	2.2
120 (130.5)	70 (80)	200	264	100	50	100	100	50	2	2	2.4	2.6
220 (230.5)	170 (180)	300	364	200	50	200	200	50	3	2	3.1	3.3
320 (330.5)	270 (280)	400	464	300	50	200	200	100	4	2	3.8	4
420 (430.5)	370 (380)	500	564	400	50	200	400	50	5	3	4.6	4.8
520 (530.5)	470 (480)	600	664	500	50	200	400	100	6	3	5.3	5.5
620 (630.5)	570 (580)	700	764	600	50	200	600	50	7	4	6	6.2

*Indicates a value when two inner blocks are in close contact with each other.

SKR33 With Cover, Motor Wrap

Model SKR33□□C (with a Single Short Nut Block)

Model SKR33□□D (with Two Short Nut Blocks)

For model number coding, see **A2-28**.

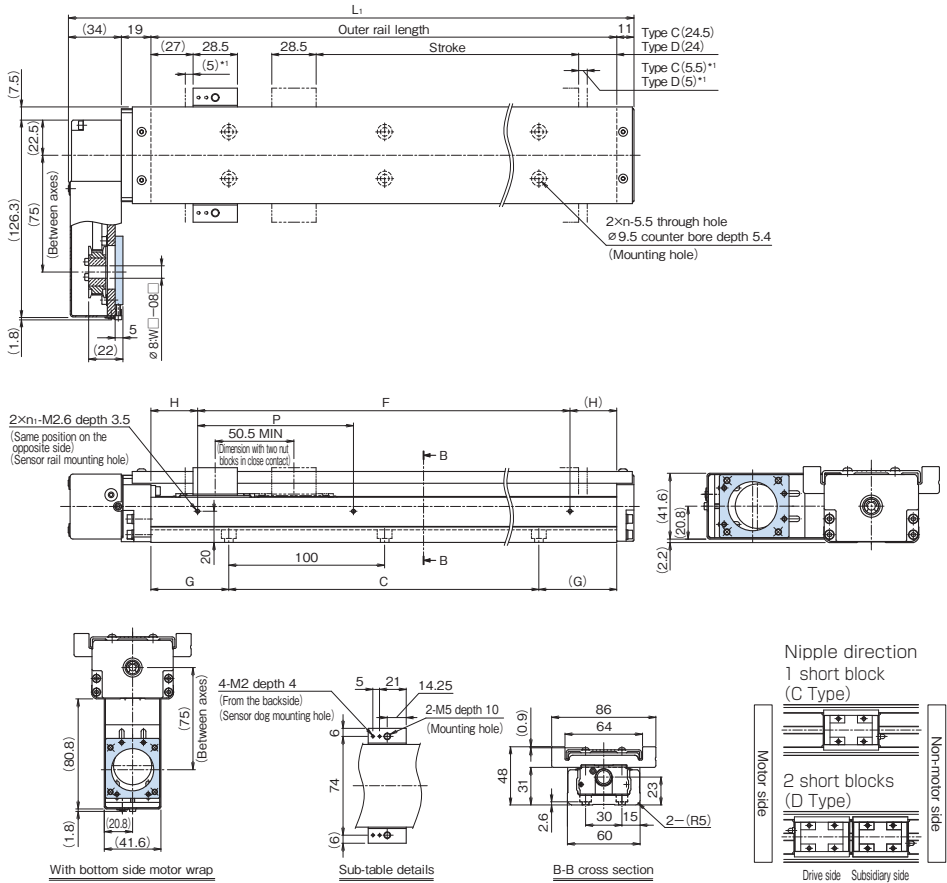

*1 Distance between the mechanical stopper and the stroke starting position.

Stroke (mm) (stroke between mechanical stoppers)		Outer rail length (mm)	Overall length L_1 (mm)	C (mm)	G (mm)	P (mm)	F (mm)	H (mm)	n	n_1	Overall main unit mass (kg)	
Type C	Type D*										Type C	Type D
70 (80.5)	20 (30)	150	214	100	25	100	100	25	2	2	2.2	2.5
120 (130.5)	70 (80)	200	264	100	50	100	100	50	2	2	2.6	2.9
220 (230.5)	170 (180)	300	364	200	50	200	200	50	3	2	3.4	3.7
320 (330.5)	270 (280)	400	464	300	50	200	200	100	4	2	4.1	4.4
420 (430.5)	370 (380)	500	564	400	50	200	400	50	5	3	4.9	5.2
520 (530.5)	470 (480)	600	664	500	50	200	400	100	6	3	5.7	6
620 (630.5)	570 (580)	700	764	600	50	200	600	50	7	4	6.4	6.7

*Indicates a value when two inner blocks are in close contact with each other.

SKR46 Without Cover, Direct Motor Coupling

Model SKR46□□A (with a Single Long Nut Block)

Model SKR46□□B (with Two Long Nut Blocks)

For model number coding, see **A2-28**.

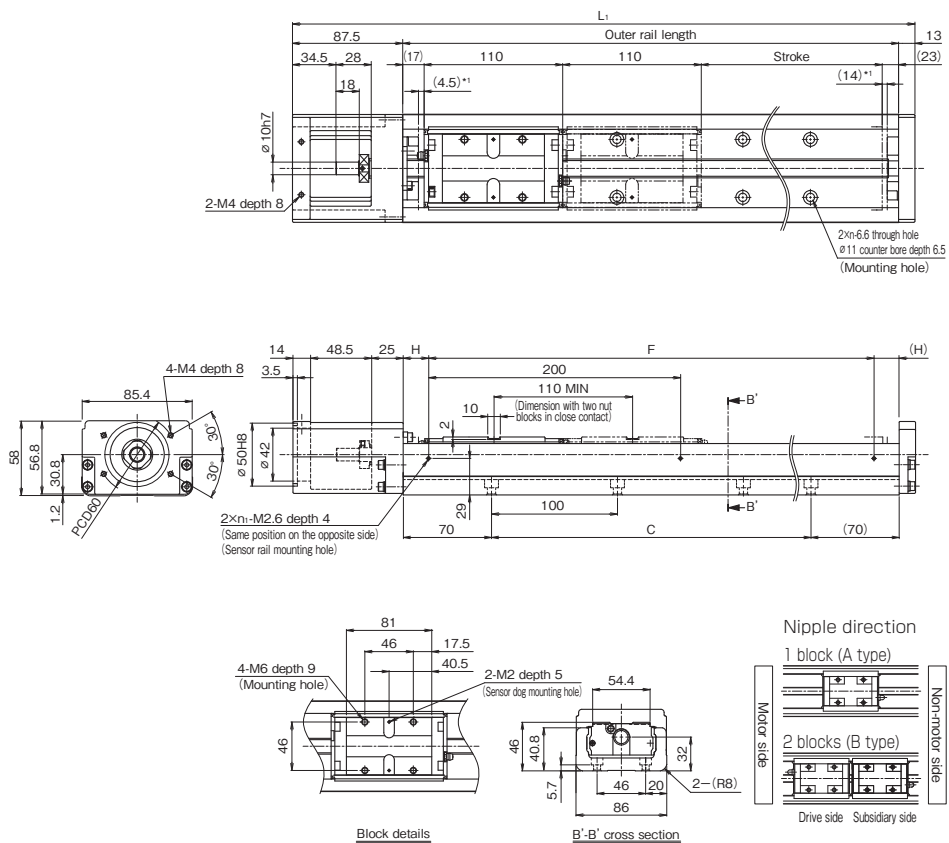

*1 Distance between the mechanical stopper and the stroke starting position.

Stroke (mm) (stroke between mechanical stoppers)		Outer rail length (mm)	Overall length L ₁ (mm)	C (mm)	F (mm)	H (mm)	n	n ₁	Overall main unit mass (kg)	
Type A	Type B*								Type A	Type B
190 (208.5)	80 (98.5)	340	440.5	200	200	70	3	2	6.7	7.7
290 (308.5)	180 (198.5)	440	540.5	300	400	20	4	3	8.1	9.1
390 (408.5)	280 (298.5)	540	640.5	400	400	70	5	3	9.5	10.5
490 (508.5)	380 (398.5)	640	740.5	500	600	20	6	4	10.9	11.9
590 (608.5)	480 (498.5)	740	840.5	600	600	70	7	4	12.3	13.3
690 (708.5)	580 (598.5)	840	940.5	700	800	20	8	5	13.8	14.8
790 (808.5)	680 (698.5)	940	1040.5	800	800	70	9	5	15.2	16.2

*Indicates a value when two inner blocks are in close contact with each other.

SKR46 With Cover, Direct Motor Coupling

Model SKR46□□A (with a Single Long Nut Block)

Model SKR46□□B (with Two Long Nut Blocks)

For model number coding, see **A2-28**.

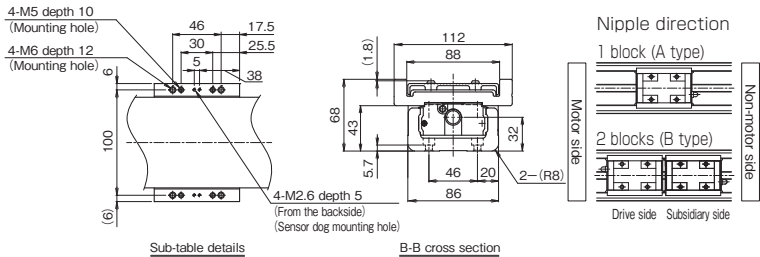
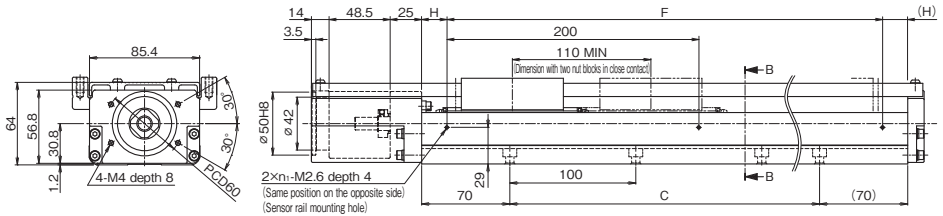
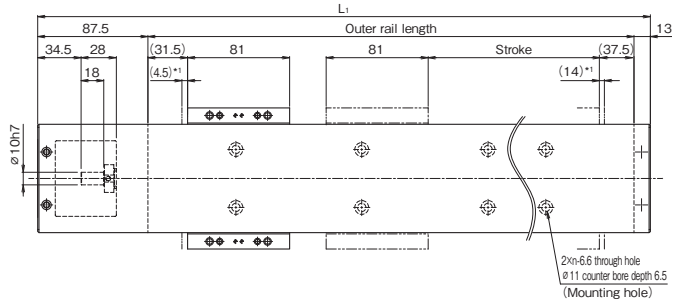

*1 Distance between the mechanical stopper and the stroke starting position.

Stroke (mm) (stroke between mechanical stoppers)		Outer rail length (mm)	Overall length L_1 (mm)	C (mm)	F (mm)	H (mm)	n	n_1	Overall main unit mass (kg)	
Type A	Type B								Type A	Type B
190 (208.5)	80 (98.5)	340	440.5	200	200	70	3	2	7.7	9.1
290 (308.5)	180 (198.5)	440	540.5	300	400	20	4	3	9.2	10.6
390 (408.5)	280 (298.5)	540	640.5	400	400	70	5	3	10.7	12.1
490 (508.5)	380 (398.5)	640	740.5	500	600	20	6	4	12.2	13.6
590 (608.5)	480 (498.5)	740	840.5	600	600	70	7	4	13.7	15.1
690 (708.5)	580 (598.5)	840	940.5	700	800	20	8	5	15.2	16.6
790 (808.5)	680 (698.5)	940	1040.5	800	800	70	9	5	16.7	18.1

*Indicates a value when two inner blocks are in close contact with each other.

SKR46 Without Cover, Motor Wrap

Model SKR46□□A (with a Single Long Nut Block)

Model SKR46□□B (with Two Long Nut Blocks)

For model number coding, see **A2-28**.

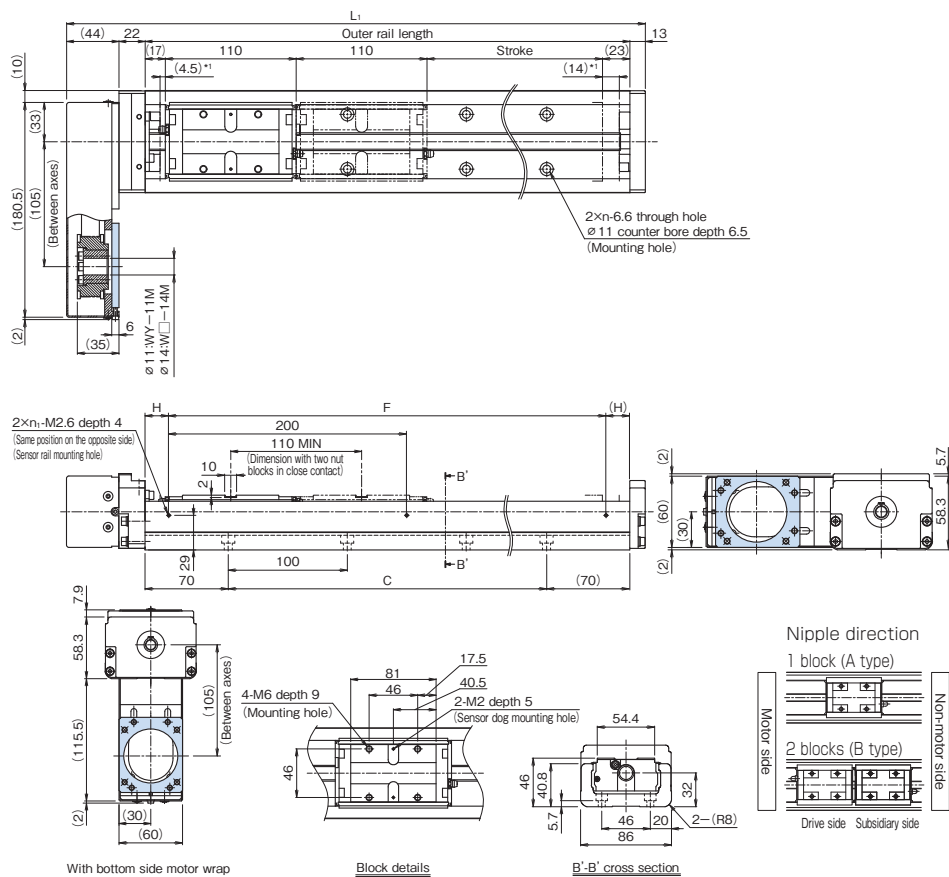

*1 Distance between the mechanical stopper and the stroke starting position.

Stroke (mm) (stroke between mechanical stoppers)		Outer rail length (mm)	Overall length L_1 (mm)	C (mm)	F (mm)	H (mm)	n	n_1	Overall main unit mass (kg)	
Type A	Type B								Type A	Type B
190 (208.5)	80 (98.5)	340	419	200	200	70	3	2	7.7	8.7
290 (308.5)	180 (198.5)	440	519	300	400	20	4	3	9.1	10.1
390 (408.5)	280 (298.5)	540	619	400	400	70	5	3	10.5	11.5
490 (508.5)	380 (398.5)	640	719	500	600	20	6	4	11.9	12.9
590 (608.5)	480 (498.5)	740	819	600	600	70	7	4	13.3	14.3
690 (708.5)	580 (598.5)	840	919	700	800	20	8	5	14.7	15.7
790 (808.5)	680 (698.5)	940	1019	800	800	70	9	5	16.1	17.1

*Indicates a value when two inner blocks are in close contact with each other.

SKR46 With Cover, Motor Wrap

Model SKR46□□A (with a Single Long Nut Block)

Model SKR46□□B (with Two Long Nut Blocks)

For model number coding, see **A2-28**.

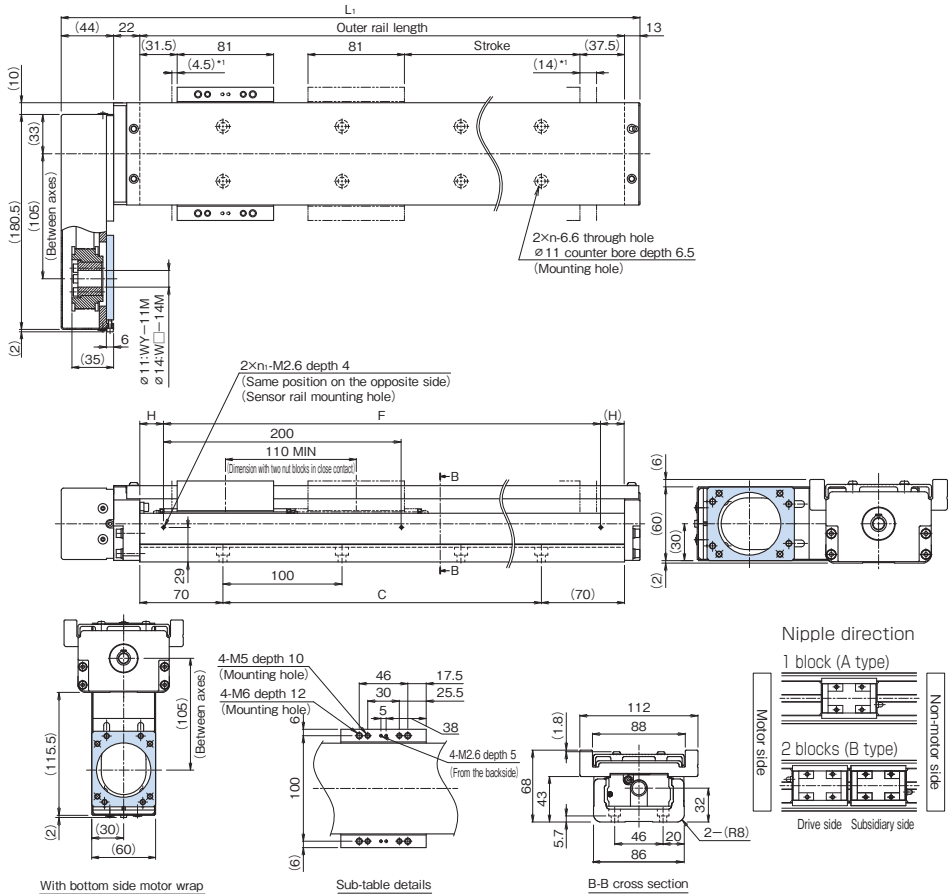

*1 Distance between the mechanical stopper and the stroke starting position.

Stroke (mm) (stroke between mechanical stoppers)		Outer rail length (mm)	Overall length L ₁ (mm)	C (mm)	F (mm)	H (mm)	n	n ₁	Overall main unit mass (kg)	
Type A	Type B [*]								Type A	Type B
190 (208.5)	80 (98.5)	340	419	200	200	70	3	2	8.6	10
290 (308.5)	180 (198.5)	440	519	300	400	20	4	3	10.1	11.5
390 (408.5)	280 (298.5)	540	619	400	400	70	5	3	11.6	13
490 (508.5)	380 (398.5)	640	719	500	600	20	6	4	13.1	14.5
590 (608.5)	480 (498.5)	740	819	600	600	70	7	4	14.6	16
690 (708.5)	580 (598.5)	840	919	700	800	20	8	5	16.1	17.5
790 (808.5)	680 (698.5)	940	1019	800	800	70	9	5	17.6	19

*Indicates a value when two inner blocks are in close contact with each other.

SKR46 Without Cover, Direct Motor Coupling

Model SKR46□□C (with a Single Short Nut Block)

Model SKR46□□D (with Two Short Nut Blocks)

For model number coding, see **A2-28**.

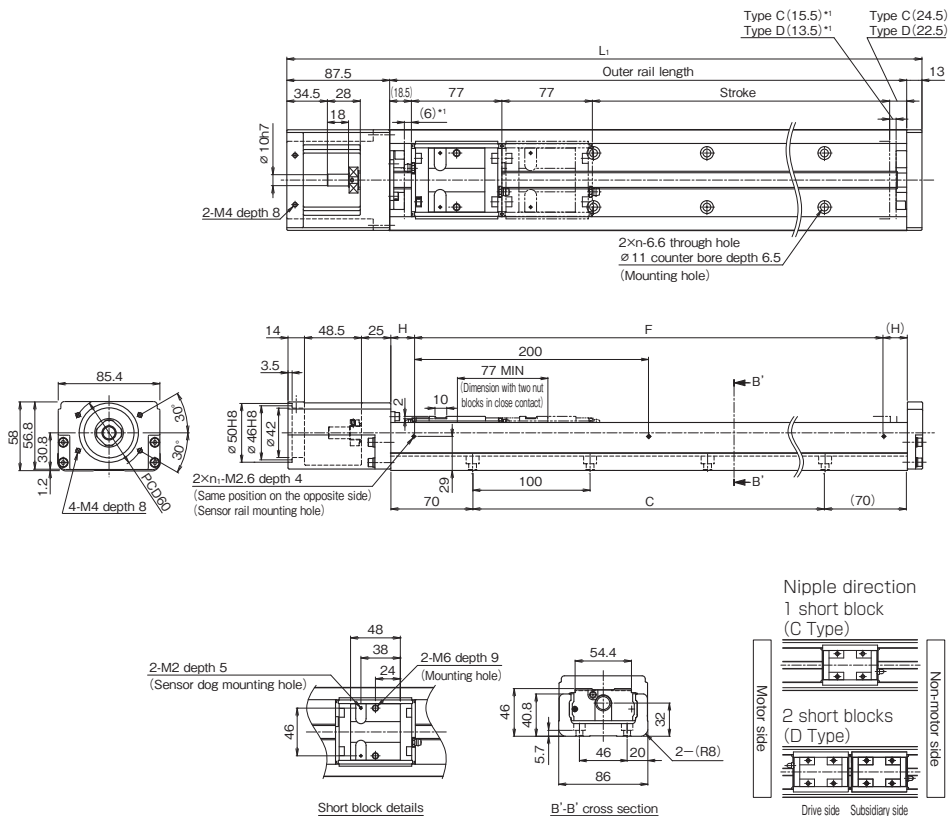

*1 Distance between the mechanical stopper and the stroke starting position.

Stroke (mm) (stroke between mechanical stoppers)		Outer rail length (mm)	Overall length L ₁ (mm)	C (mm)	F (mm)	H (mm)	n	n ₁	Overall main unit mass (kg)	
Type C	Type D*								Type C	Type D
220 (241.5)	145 (164.5)	340	440.5	200	200	70	3	2	6.3	6.9
320 (341.5)	245 (264.5)	440	540.5	300	400	20	4	3	7.7	8.3
420 (441.5)	345 (364.5)	540	640.5	400	400	70	5	3	9.1	9.7
520 (541.5)	445 (464.5)	640	740.5	500	600	20	6	4	10.5	11.1
620 (641.5)	545 (564.5)	740	840.5	600	600	70	7	4	11.9	12.5
720 (741.5)	645 (664.5)	840	940.5	700	800	20	8	5	13.4	14
820 (841.5)	745 (764.5)	940	1040.5	800	800	70	9	5	14.8	15.4

*Indicates a value when two inner blocks are in close contact with each other.

SKR46 With Cover, Direct Motor Coupling

Model SKR46□□C (with a Single Short Nut Block)

Model SKR46□□D (with Two Short Nut Blocks)

For model number coding, see **A2-28**.

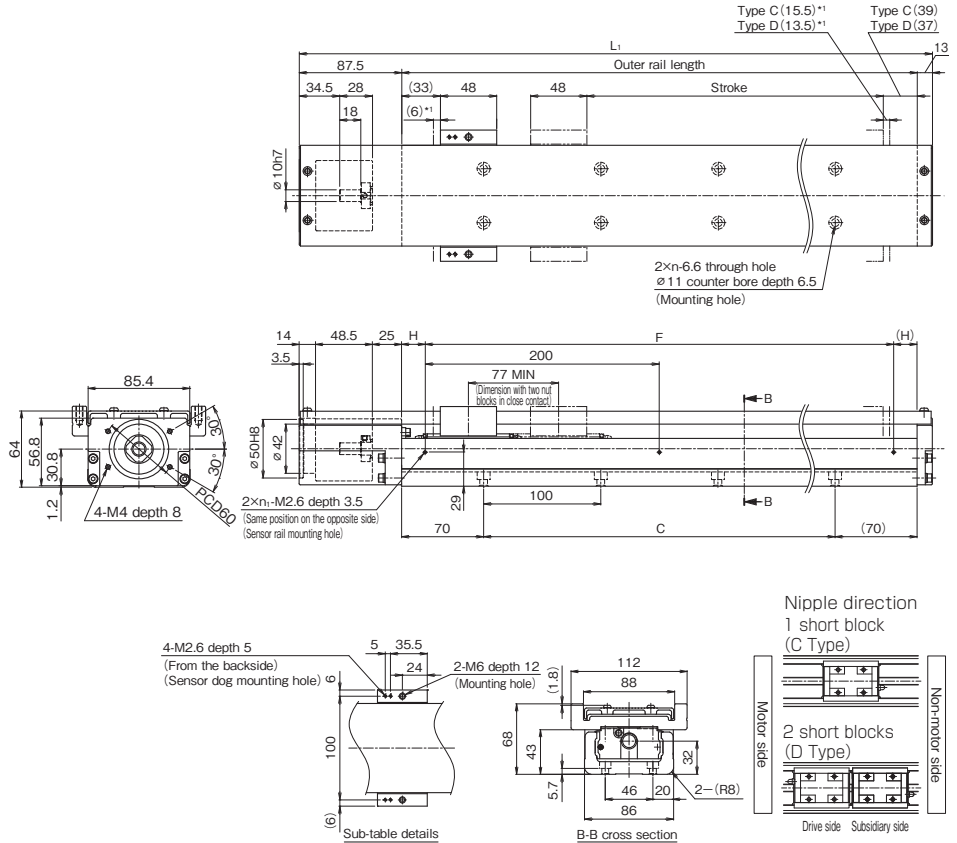

*1 Distance between the mechanical stopper and the stroke starting position.

Stroke (mm) (stroke between mechanical stoppers)		Outer rail length (mm)	Overall length L_1 (mm)	C (mm)	F (mm)	H (mm)	n	n_1	Overall main unit mass (kg)	
Type C	Type D								Type C	Type D
220 (241.5)	145 (164.5)	340	440.5	200	200	70	3	2	7.1	7.9
320 (341.5)	245 (264.5)	440	540.5	300	400	20	4	3	8.6	9.4
420 (441.5)	345 (364.5)	540	640.5	400	400	70	5	3	10.1	10.9
520 (541.5)	445 (464.5)	640	740.5	500	600	20	6	4	11.6	12.4
620 (641.5)	545 (564.5)	740	840.5	600	600	70	7	4	13.1	13.9
720 (741.5)	645 (664.5)	840	940.5	700	800	20	8	5	14.6	15.4
820 (841.5)	745 (764.5)	940	1040.5	800	800	70	9	5	16.1	16.9

*Indicates a value when two inner blocks are in close contact with each other.

SKR46 Without Cover, Motor Wrap

Model SKR46□□C (with a Single Short Nut Block)

Model SKR46□□D (with Two Short Nut Blocks)

For model number coding, see **A2-28**.

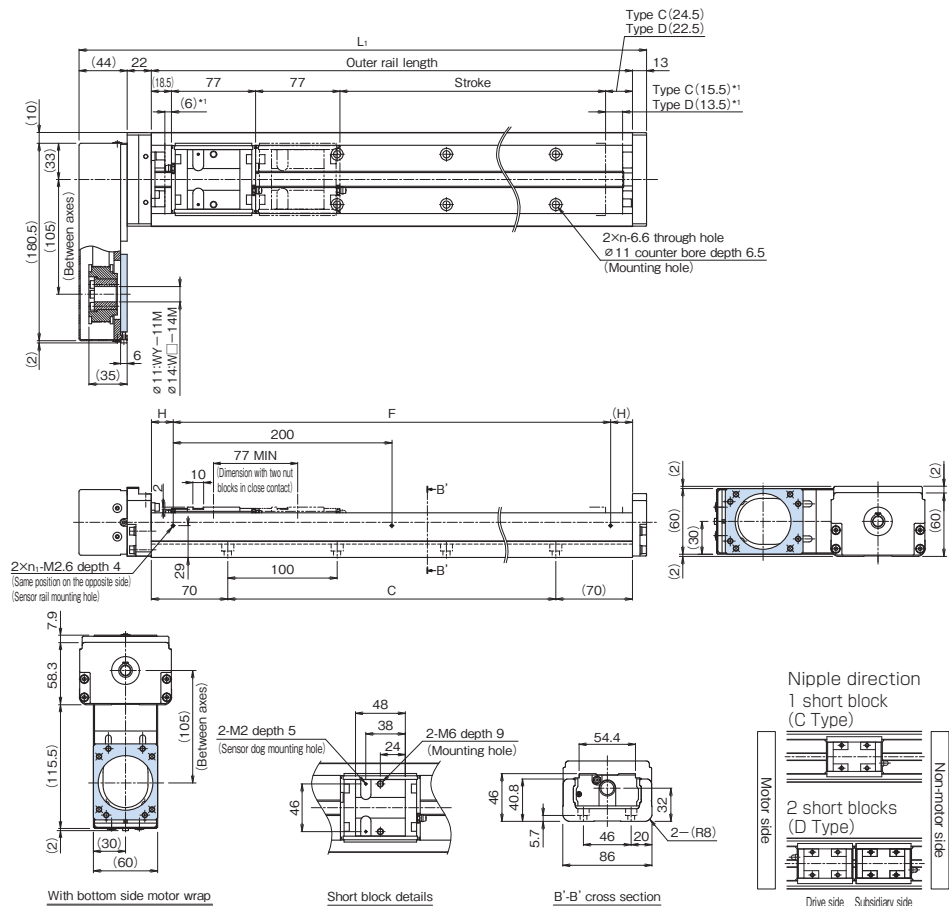

With bottom side motor wrap

Short block details

B'-B' cross section

*1 Distance between the mechanical stopper and the stroke starting position.

Stroke (mm) (stroke between mechanical stoppers)		Outer rail length (mm)	Overall length L_1 (mm)	C (mm)	F (mm)	H (mm)	n	n_1	Overall main unit mass (kg)	
Type C	Type D								Type C	Type D
220 (241.5)	145 (164.5)	340	419	200	200	70	3	2	7.3	7.9
320 (341.5)	245 (264.5)	440	519	300	400	20	4	3	8.7	9.3
420 (441.5)	345 (364.5)	540	619	400	400	70	5	3	10.1	10.7
520 (541.5)	445 (464.5)	640	719	500	600	20	6	4	11.5	12.1
620 (641.5)	545 (564.5)	740	819	600	600	70	7	4	12.9	13.5
720 (741.5)	645 (664.5)	840	919	700	800	20	8	5	14.3	14.9
820 (841.5)	745 (764.5)	940	1019	800	800	70	9	5	15.7	16.3

*Indicates a value when two inner blocks are in close contact with each other.

SKR55 Without Cover, Direct Motor Coupling

Model SKR55□□A (with a Single Long Nut Block)

Model SKR55□□B (with Two Long Nut Blocks)

For model number coding, see **A2-28**.

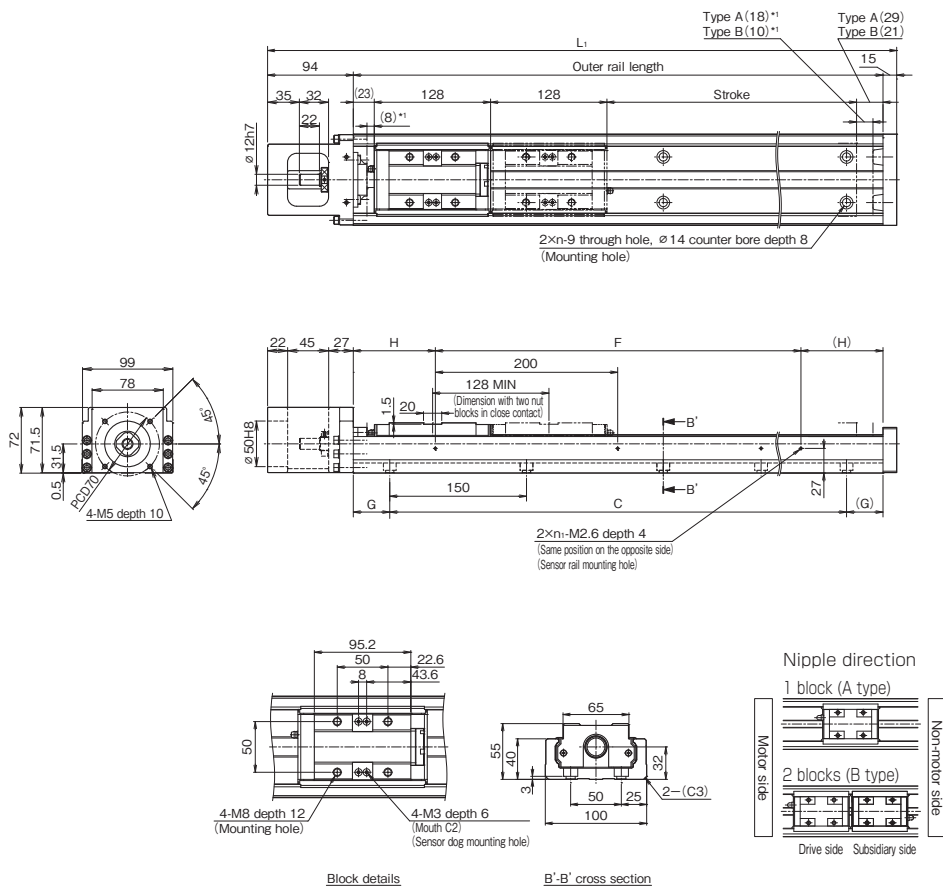

*1 Distance between the mechanical stopper and the stroke starting position.

Stroke (mm) (stroke between mechanical stoppers)		Outer rail length (mm)	Overall length L ₁ (mm)	C (mm)	G (mm)	F (mm)	H (mm)	n	n ₁	Overall main unit mass (kg)	
Type A	Type B'									Type A	Type B
800 (826)	680 (698)	980	1089	900	40	800	90	7	5	20.9	22.8
900 (926)	780 (798)	1080	1189	1050	15	1000	40	8	6	22.6	24.5
1000 (1026)	880 (898)	1180	1289	1050	65	1000	90	8	6	24.4	26.3
1100 (1126)	980 (998)	1280	1389	1200	40	1200	40	9	7	26.2	28.1
1200 (1226)	1080 (1098)	1380	1489	1350	15	1200	90	10	7	27.9	29.8

*Indicates a value when two inner blocks are in close contact with each other.

SKR55 With Cover, Direct Motor Coupling

Model SKR55□□A (with a Single Long Nut Block)

Model SKR55□□B (with Two Long Nut Blocks)

For model number coding, see **A2-28**.

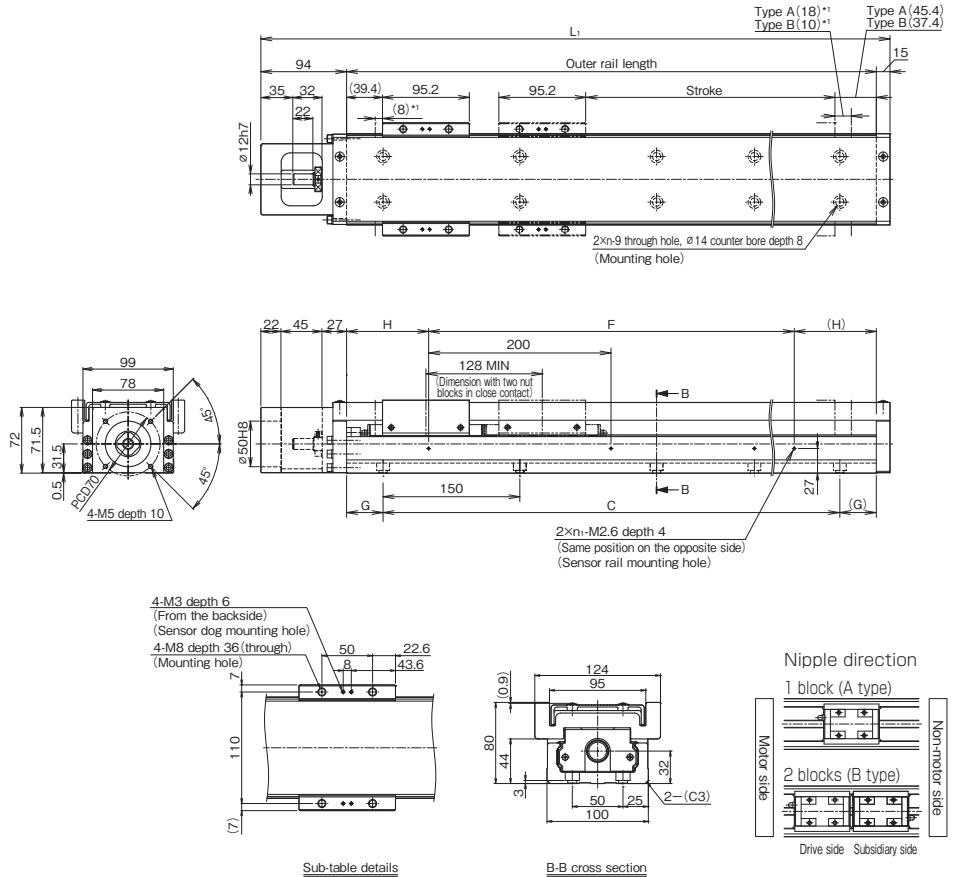

*1 Distance between the mechanical stopper and the stroke starting position.

Stroke (mm) (stroke between mechanical stoppers)		Outer rail length (mm)	Overall length L_1 (mm)	C (mm)	G (mm)	F (mm)	H (mm)	n	n_1	Overall main unit mass (kg)	
Type A	Type B*									Type A	Type B
800 (826)	680 (698)	980	1089	900	40	800	90	7	5	23.8	27.6
900 (926)	780 (798)	1080	1189	1050	15	1000	40	8	6	25.7	29.5
1000 (1026)	880 (898)	1180	1289	1050	65	1000	90	8	6	27.6	31.4
1100 (1126)	980 (998)	1280	1389	1200	40	1200	40	9	7	29.5	33.3
1200 (1226)	1080 (1098)	1380	1489	1350	15	1200	90	10	7	31.4	35.2

*Indicates a value when two inner blocks are in close contact with each other.

SKR55 Without Cover, Motor Wrap Motor Flange Angle, 60×60

Model SKR55□□A (with a Single Long Nut Block)

Model SKR55□□B (with Two Long Nut Blocks)

For model number coding, see **A2-28**.

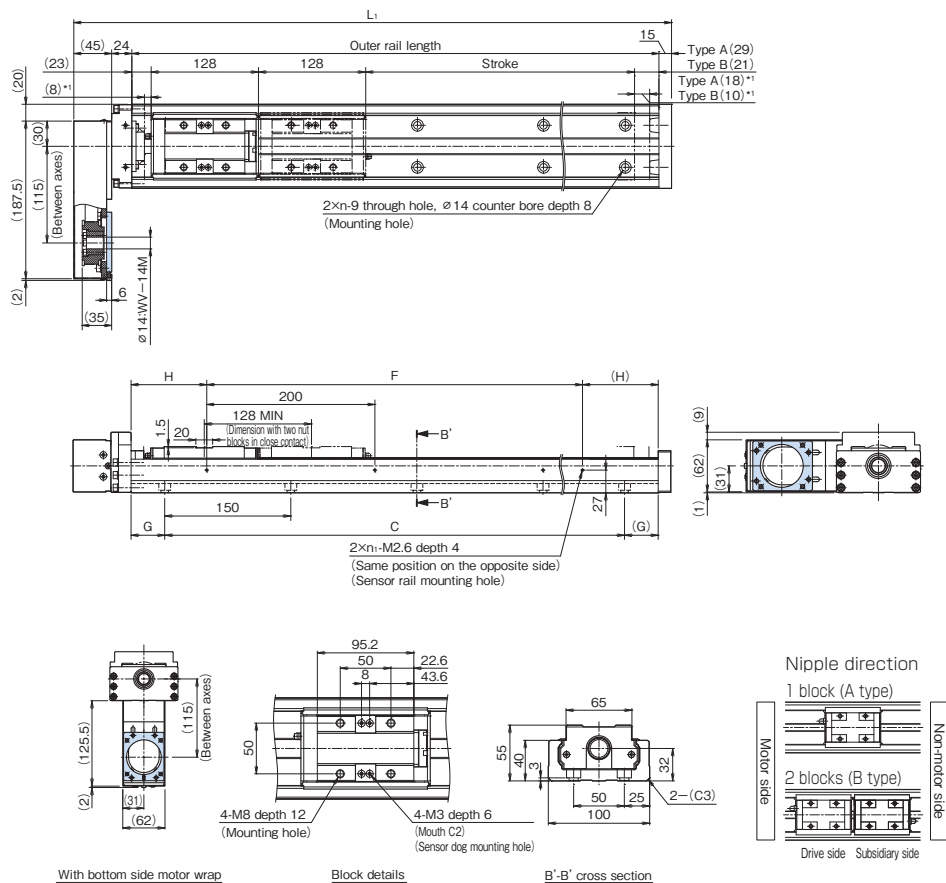

*1 Distance between the mechanical stopper and the stroke starting position.

Stroke (mm) (stroke between mechanical stoppers)		Outer rail length (mm)	Overall length L ₁ (mm)	C (mm)	G (mm)	F (mm)	H (mm)	n	n ₁	Overall main unit mass (kg)	
Type A	Type B*									Type A	Type B
800 (826)	680 (698)	980	1064	900	40	800	90	7	5	21.8	23.7
900 (926)	780 (798)	1080	1164	1050	15	1000	40	8	6	23.6	25.5
1000 (1026)	880 (898)	1180	1264	1050	65	1000	90	8	6	25.3	27.2
1100 (1126)	980 (998)	1280	1364	1200	40	1200	40	9	7	27.1	29
1200 (1226)	1080 (1098)	1380	1464	1350	15	1200	90	10	7	28.9	30.8

*Indicates a value when two inner blocks are in close contact with each other.

SKR55 With Cover, Motor Wrap Motor Flange Angle, 60×60

Model SKR55□□A (with a Single Long Nut Block)

Model SKR55□□B (with Two Long Nut Blocks)

For model number coding, see **A2-28**.

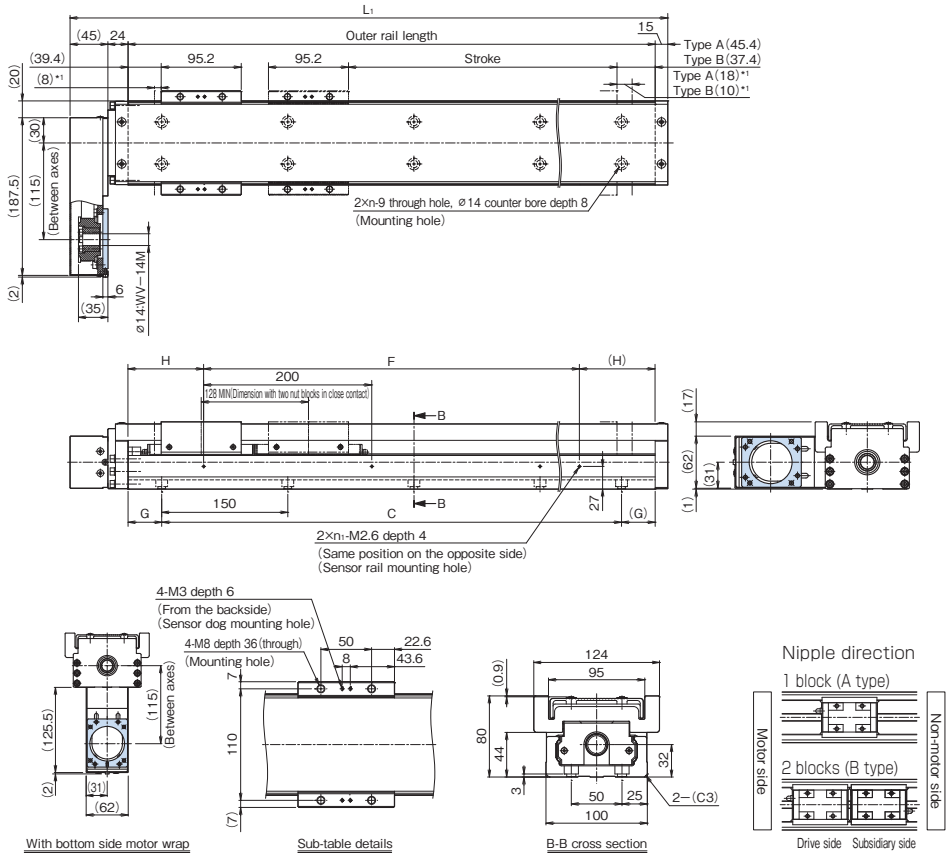

*1 Distance between the mechanical stopper and the stroke starting position.

Stroke (mm) (stroke between mechanical stoppers)		Outer rail length (mm)	Overall length L ₁ (mm)	C (mm)	G (mm)	F (mm)	H (mm)	n	n ₁	Overall main unit mass (kg)	
Type A	Type B*									Type A	Type B
800 (826)	680 (698)	980	1064	900	40	800	90	7	5	24.8	28.6
900 (926)	780 (798)	1080	1164	1050	15	1000	40	8	6	26.7	30.5
1000 (1026)	880 (898)	1180	1264	1050	65	1000	90	8	6	28.6	32.4
1100 (1126)	980 (998)	1280	1364	1200	40	1200	40	9	7	30.5	34.3
1200 (1226)	1080 (1098)	1380	1464	1350	15	1200	90	10	7	32.4	36.2

*Indicates a value when two inner blocks are in close contact with each other.

SKR55 Without Cover, Motor Wrap Motor Flange Angle, 80×80

Model SKR55□□A (with a Single Long Nut Block)

Model SKR55□□B (with Two Long Nut Blocks)

For model number coding, see **A2-28**.

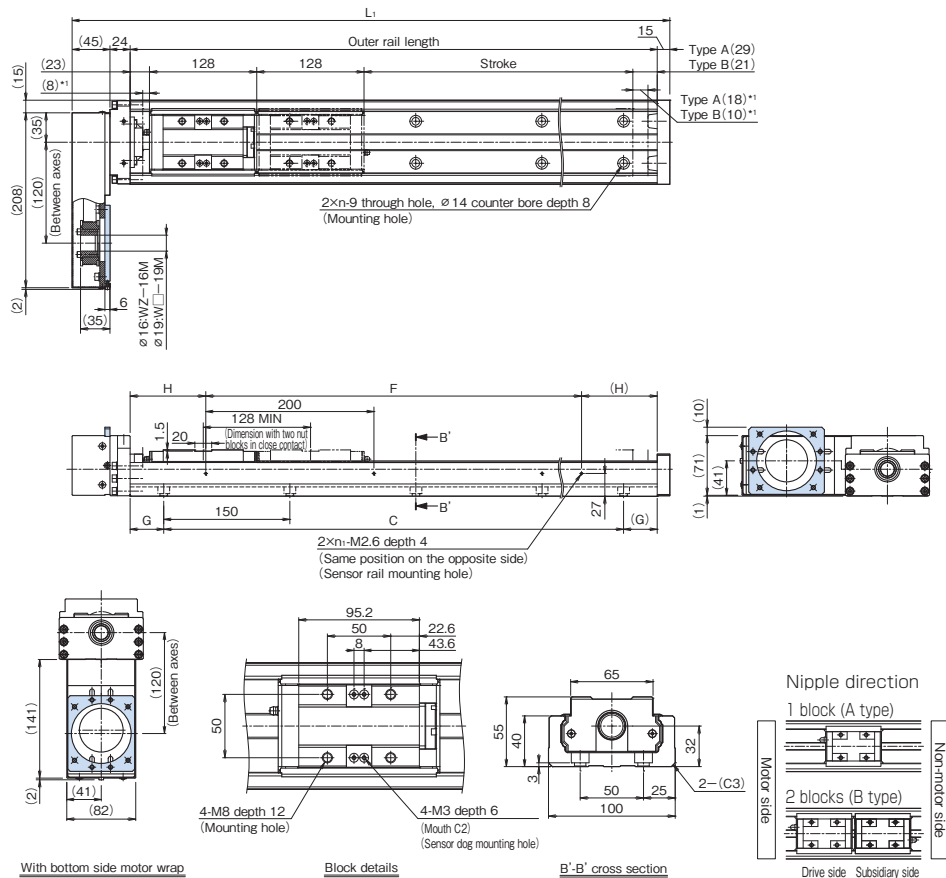

*1 Distance between the mechanical stopper and the stroke starting position.

Stroke (mm) (stroke between mechanical stoppers)		Outer rail length (mm)	Overall length L_1 (mm)	C (mm)	G (mm)	F (mm)	H (mm)	n	n_1	Overall main unit mass (kg)	
Type A	Type B									Type A	Type B
800 (826)	680 (698)	980	1064	900	40	800	90	7	5	21.8	23.7
900 (926)	780 (798)	1080	1164	1050	15	1000	40	8	6	23.6	25.5
1000 (1026)	880 (898)	1180	1264	1050	65	1000	90	8	6	25.3	27.2
1100 (1126)	980 (998)	1280	1364	1200	40	1200	40	9	7	27.1	29
1200 (1226)	1080 (1098)	1380	1464	1350	15	1200	90	10	7	28.9	30.8

*Indicates a value when two inner blocks are in close contact with each other.

SKR55 With Cover, Motor Wrap Motor Flange Angle, 80×80

Model SKR55□□A (with a Single Long Nut Block)

Model SKR55□□B (with Two Long Nut Blocks)

For model number coding, see **A2-28**.

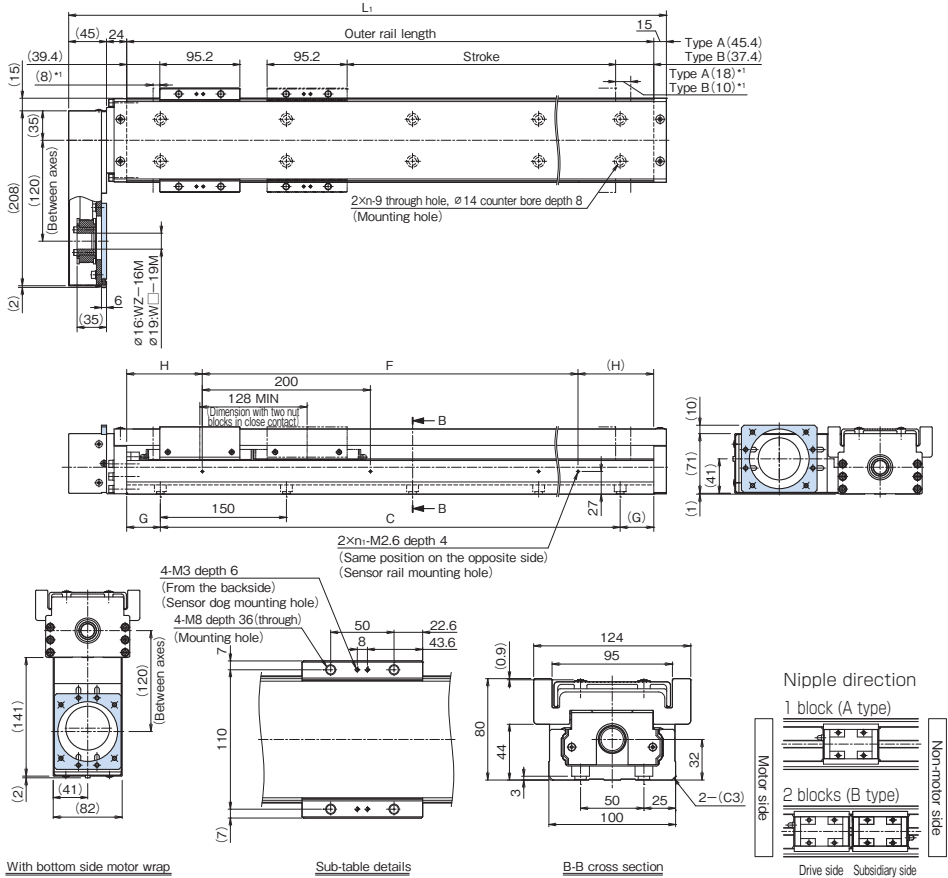

With bottom side motor wrap

Sub-table details

B-B cross section

*1 Distance between the mechanical stopper and the stroke starting position.

Stroke (mm) (stroke between mechanical stoppers)		Outer rail length (mm)	Overall length L_1 (mm)	C (mm)	G (mm)	F (mm)	H (mm)	n	n_1	Overall main unit mass (kg)	
Type A	Type B*									Type A	Type B
800 (826)	680 (698)	980	1064	900	40	800	90	7	5	24.8	28.6
900 (926)	780 (798)	1080	1164	1050	15	1000	40	8	6	26.7	30.5
1000 (1026)	880 (898)	1180	1264	1050	65	1000	90	8	6	28.6	32.4
1100 (1126)	980 (998)	1280	1364	1200	40	1200	40	9	7	30.5	34.3
1200 (1226)	1080 (1098)	1380	1464	1350	15	1200	90	10	7	32.4	36.2

*Indicates a value when two inner blocks are in close contact with each other.

SKR65 Without Cover, Direct Motor Coupling

Model SKR65□□A (with a Single Long Nut Block)

Model SKR65□□B (with Two Long Nut Blocks)

For model number coding, see **A2-28**.

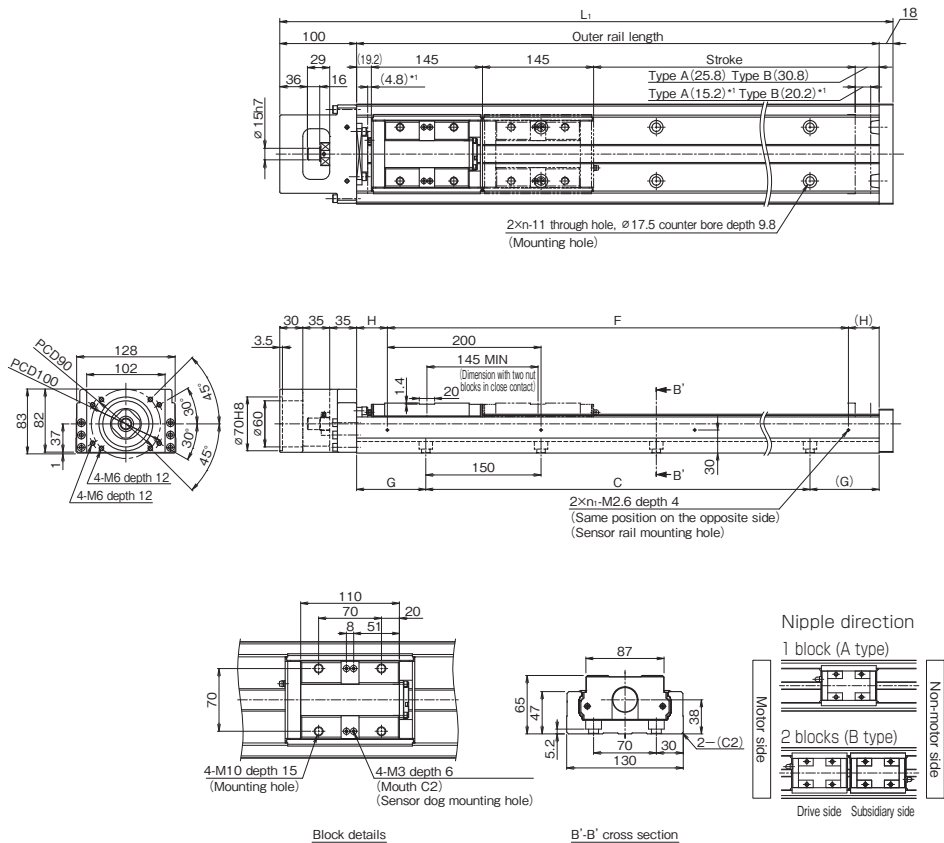

*1 Distance between the mechanical stopper and the stroke starting position.

Stroke (mm) (stroke between mechanical stoppers)		Outer rail length (mm)	Overall length L_1 (mm)	C (mm)	G (mm)	F (mm)	H (mm)	n	n_1	Overall main unit mass (kg)	
Type A	Type B*									Type A	Type B
790 (810)	640 (665)	980	1098	900	40	800	90	7	5	30.3	33.3
990 (1010)	840 (865)	1180	1298	1050	65	1000	90	8	6	35.5	38.5
1190 (1210)	1040 (1065)	1380	1498	1200	90	1200	90	9	7	40.7	43.7
1490 (1510)	1340 (1365)	1680	1798	1500	90	1600	40	11	9	48.4	51.4

*Indicates a value when two inner blocks are in close contact with each other.

SKR65 With Cover, Direct Motor Coupling

Model SKR65□□A (with a Single Long Nut Block)

Model SKR65□□B (with Two Long Nut Blocks)

For model number coding, see **A2-28**.

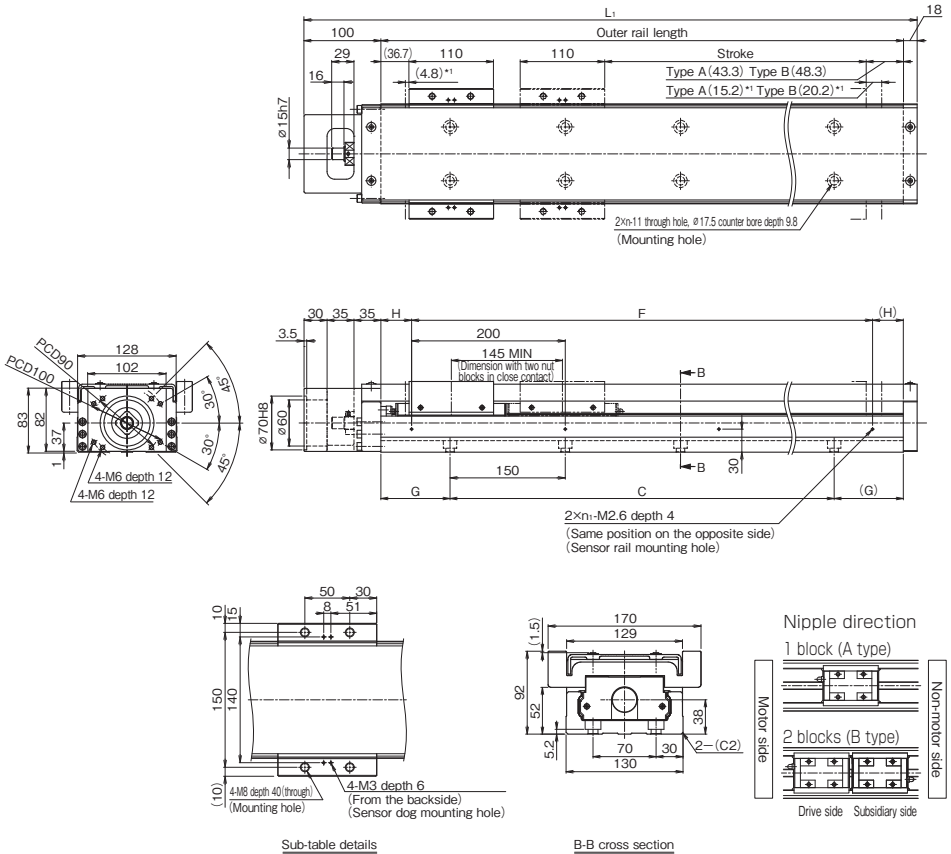

*1 Distance between the mechanical stopper and the stroke starting position.

Stroke (mm) (stroke between mechanical stoppers)		Outer rail length (mm)	Overall length L_1 (mm)	C (mm)	G (mm)	F (mm)	H (mm)	n	n_1	Overall main unit mass (kg)	
Type A	Type B*									Type A	Type B
790 (810)	640 (665)	980	1098	900	40	800	90	7	5	33.5	40.2
990 (1010)	840 (865)	1180	1298	1050	65	1000	90	8	6	38.9	45.6
1190 (1210)	1040 (1065)	1380	1498	1200	90	1200	90	9	7	44.3	51
1490 (1510)	1340 (1365)	1680	1798	1500	90	1600	40	11	9	52.4	59.1

*Indicates a value when two inner blocks are in close contact with each other.

SKR65 Without Cover, Motor Wrap

Model SKR65□□A (with a Single Long Nut Block)

Model SKR65□□B (with Two Long Nut Blocks)

For model number coding, see **A2-28**.

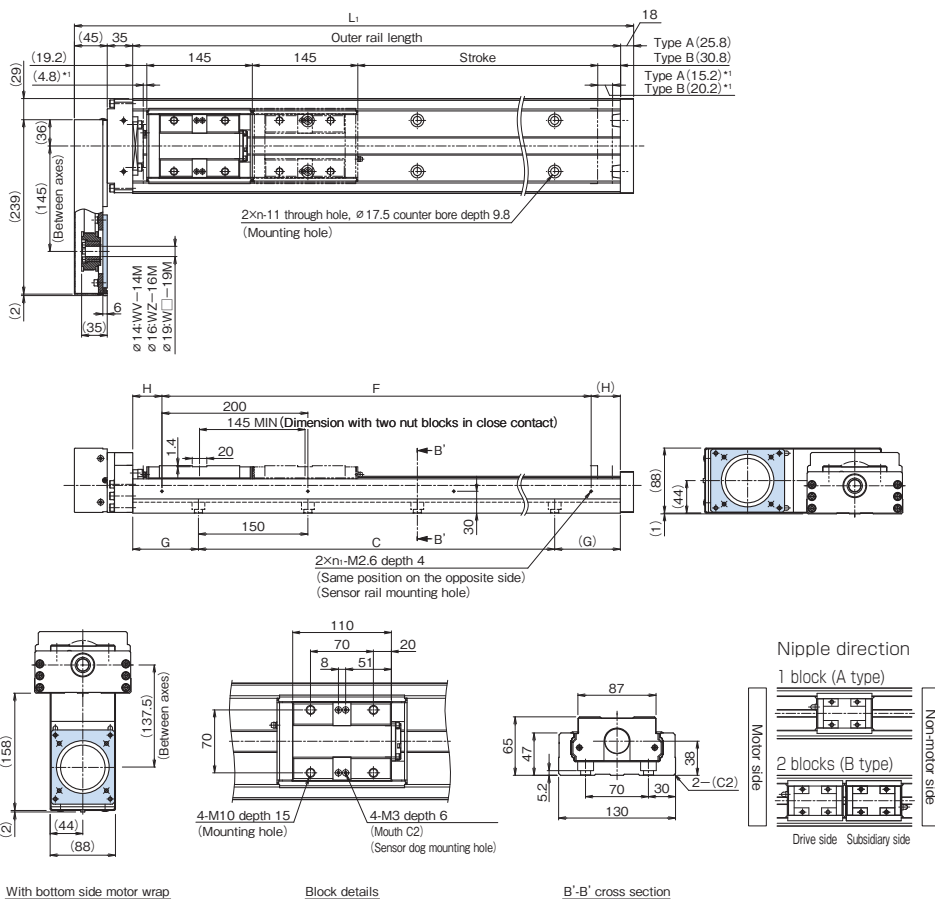

*1 Distance between the mechanical stopper and the stroke starting position.

Stroke (mm) (stroke between mechanical stoppers)		Outer rail length (mm)	Overall length L_1 (mm)	C (mm)	G (mm)	F (mm)	H (mm)	n	n_1	Overall main unit mass (kg)	
Type A	Type B*									Type A	Type B
790 (810)	640 (665)	980	1078	900	40	800	90	7	5	31.9	34.9
990 (1010)	840 (865)	1180	1278	1050	65	1000	90	8	6	37.1	40.1
1190 (1210)	1040 (1065)	1380	1478	1200	90	1200	90	9	7	42.3	45.3
1490 (1510)	1340 (1365)	1680	1778	1500	90	1600	40	11	9	50	53

*Indicates a value when two inner blocks are in close contact with each other.

SKR65 With Cover, Motor Wrap

Model SKR65□□□A (with a Single Long Nut Block)

Model SKR65□□□B (with Two Long Nut Blocks)

For model number coding, see **A2-28**.

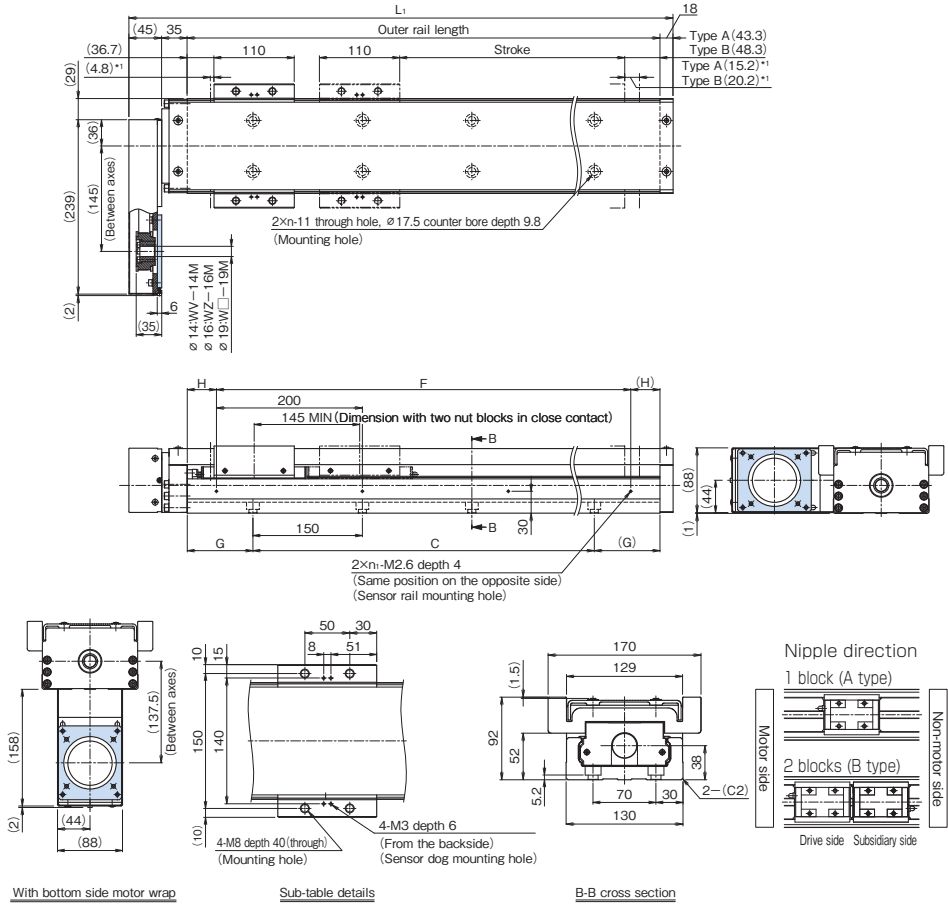

*1 Distance between the mechanical stopper and the stroke starting position.

Stroke (mm) (stroke between mechanical stoppers)		Outer rail length (mm)	Overall length L_1 (mm)	C (mm)	G (mm)	F (mm)	H (mm)	n	n_1	Overall main unit mass (kg)	
Type A	Type B*									Type A	Type B
790 (810)	640 (665)	980	1078	900	40	800	90	7	5	35.1	41.8
990 (1010)	840 (865)	1180	1278	1050	65	1000	90	8	6	40.5	47.2
1190 (1210)	1040 (1065)	1380	1478	1200	90	1200	90	9	7	45.9	52.6
1490 (1510)	1340 (1365)	1680	1778	1500	90	1600	40	11	9	54	60.7

*Indicates a value when two inner blocks are in close contact with each other.

Mass of Moving Elements

Table14 shows the mass of the inner block and top table of model SKR.

Table14 Mass of the Inner Block and Top Table of SKR

Unit: kg

Model No.	Long nut block types				Short nut block types			
	A/B	Inner block	Top table	Total mass	C/D	Inner block	Top table	Total mass
SKR20	Type A	0.07	0.05	0.12	Type C	—	—	—
	Type B	0.14	0.1	0.24	Type D	—	—	—
SKR26	Type A	0.17	0.08	0.25	Type C	—	—	—
	Type B	0.34	0.16	0.5	Type D	—	—	—
SKR33	Type A	0.4	0.2	0.6	Type C	0.2	0.1	0.3
	Type B	0.8	0.4	1.2	Type D	0.4	0.2	0.6
SKR46	Type A	1.0	0.4	1.4	Type C	0.6	0.2	0.8
	Type B	2.0	0.8	2.8	Type D	1.2	0.4	1.6
SKR55	Type A	1.9	1.9	3.8	Type C	—	—	—
	Type B	3.8	3.8	7.6	Type D	—	—	—
SKR65	Type A	3.0	3.7	6.7	Type C	—	—	—
	Type B	6.0	7.4	13.4	Type D	—	—	—

QZ Lubricator (compatible models: SKR33, SKR46)

The QZ Lubricator for SKR feeds the proper amount of lubricant to the outer rail and ball screw shaft raceway. This allows an oil film to be constantly formed between the balls and the raceway, significantly extending the lubrication maintenance interval.

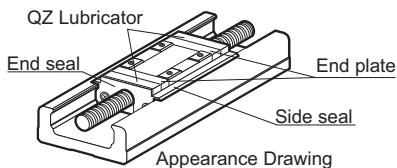

[Features]

- Since it supplements lost oil, the lubrication maintenance interval can be significantly extended.
- This is an eco-friendly lubrication system that does not contaminate the surrounding area because it feeds the correct amount of lubricant to the ball raceway.

[SKR-QZ Configuration]

Symbol	Block type	Description
QZ	A/B/C/D	QZ with all blocks both sides specification
QZA	A/C	QZ with fixed side specification
QZB	A/C	QZ with supported side specification
QZAD	B/D	QZ with fixed side (inner block with screw) + QZ with supported side (free block) specifications

Note) The QZ specification does not include a grease nipple. Contact THK if a grease nipple is required.

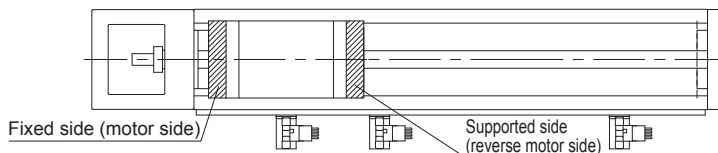

Constitution	QZ	QZA	QZB	QZAD
Type A (with a Single Long Nut Block)				—
Type B (with Two Long Nut Blocks)		—	—	
Type C (with a Single Short Nut Block)				—
Type D (with Two Short Nut Blocks)		—	—	

[Dimensions with QZ Lubricator]

Code: QZ (with cover)

Model No. : SKR33/46

Block type : A/B/C/D

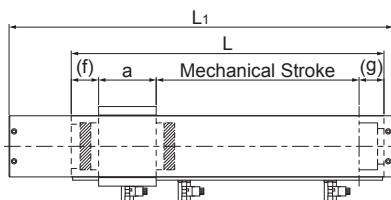

Block type A/C

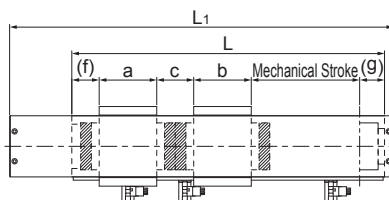

Block type B/D

Unit: mm

Model No.	Block type	Overall length L_1	Outer rail length L	Stroke ^{*1,2}	a	b	C	f	g
SKR33	A (3306) (3310)	220	150	—	54	—	—	35	32
		270	200	70(79)					
		370	300	170(179)					
		470	400	270(279)					
		570	500	370(379)					
		670	600	470(479)					
		770	700	570(579)					
	A (3320)	220	150	—	54	—	—	45.4	32
		270	200	—					
		370	300	155(168.6)					
		470	400	255(268.6)					
		570	500	355(368.6)					
		670	600	455(468.6)					
	770	700	555(568.6)						
	B (3306) (3310)	220	150	—	54	54	48	35	32
		270	200	—					
		370	300	65(77)					
		470	400	165(177)					
		570	500	265(277)					
		670	600	365(377)					
		770	700	465(477)					
	B (3320)	220	150	—	54	54	48	45.4	32
		270	200	—					
		370	300	—					
470		400	155(166.6)						
570		500	255(266.6)						
670		600	355(366.6)						
770		700	455(466.6)						

*1 The value in the parentheses represents the maximum stroke.

*2 The strokes for block types B and D are the values when in contact with the inner block.

Unit: mm

Model No.	Block type	Overall length L ₁	Outer rail length L	Stroke ^{*1,2}	a	b	C	f	g
SKR33	C	220	150	45(54.5)	28.5	—	—	35	32
		270	200	95(104.5)					
		370	300	195(204.5)					
		470	400	295(304.5)					
		570	500	395(404.5)					
		670	600	495(504.5)					
	770	700	595(604.5)						
	D	220	150	—	28.5	28.5	48	35	32
		270	200	—					
		370	300	115(128)					
		470	400	215(228)					
		570	500	315(328)					
670		600	415(428)						
770	700	515(528)							
SKR46	A	440.5	340	160(178.5)	81	—	—	42	38.5
		540.5	440	260(278.5)					
		640.5	540	360(378.5)					
		740.5	640	460(478.5)					
		840.5	740	560(578.5)					
		940.5	840	660(678.5)					
	1040.5	940	760(778.5)						
	B	440.5	340	—	81	81	59	42	38.5
		540.5	440	120(138.5)					
		640.5	540	220(238.5)					
		740.5	640	320(338.5)					
		840.5	740	420(438.5)					
		940.5	840	520(538.5)					
	1040.5	940	620(638.5)						
	C	440.5	340	190(211.5)	48	—	—	42	38.5
		540.5	440	290(311.5)					
		640.5	540	390(411.5)					
		740.5	640	490(511.5)					
		840.5	740	590(611.5)					
		940.5	840	690(711.5)					
	1040.5	940	790(811.5)						
	D	440.5	340	85(104.5)	48	48	59	42	38.5
		540.5	440	185(204.5)					
		640.5	540	285(304.5)					
740.5		640	385(404.5)						
840.5		740	485(504.5)						
940.5		840	585(604.5)						
1040.5	940	685(704.5)							

*1 The value in the parentheses represents the maximum stroke.

*2 The strokes for block types B and D are the values when in contact with the inner block.

Code: QZ (without cover)
 Model No. : SKR33/46
 Block type : A/B/C/D

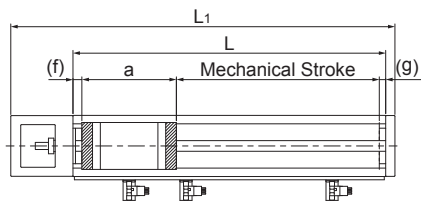

Block type A/C

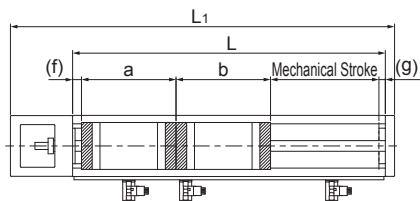

Block type B/D

Unit: mm

Model No.	Block type	Overall length L_1	Outer rail length L	Stroke ^{*1,2}	a	b	f	g
SKR33	A (3306) (3310)	220	150	—	102	—	11	8
		270	200	70(79)				
		370	300	170(179)				
		470	400	270(279)				
		570	500	370(379)				
		670	600	470(479)				
	770	700	570(579)					
	A (3320)	220	150	—	112.4	—	11	8
		270	200	—				
		370	300	155(168.6)				
		470	400	255(268.6)				
		570	500	355(368.6)				
		670	600	455(468.6)				
	770	700	555(568.6)					
	B (3306) (3310)	220	150	—	102	102	11	8
		270	200	—				
		370	300	65(77)				
		470	400	165(177)				
		570	500	265(277)				
		670	600	365(377)				
	770	700	465(477)					
	B (3320)	220	150	—	112.4	102	11	8
		270	200	—				
		370	300	—				
470		400	155(166.6)					
570		500	255(266.6)					
670		600	355(366.6)					
770	700	455(466.6)						

*1 The value in the parentheses represents the maximum stroke.

*2 The strokes for block types B and D are the values when in contact with the inner block.

Unit: mm

Model No.	Block type	Overall length L ₁	Outer rail length L	Stroke ^{*1,2}	a	b	f	g
SKR33	C	220	150	45(54.5)	76.5	—	11	8
		270	200	95(104.5)				
		370	300	195(204.5)				
		470	400	295(304.5)				
		570	500	395(404.5)				
		670	600	495(504.5)				
		770	700	595(604.5)				
	D	220	150	—	76.5	76.5	11	8
		270	200	—				
		370	300	115(128)				
		470	400	215(228)				
		570	500	315(328)				
		670	600	415(428)				
		770	700	515(528)				
SKR46	A	440.5	340	160(178.5)	140	—	12.5	9
		540.5	440	260(278.5)				
		640.5	540	360(378.5)				
		740.5	640	460(478.5)				
		840.5	740	560(578.5)				
		940.5	840	660(678.5)				
		1040.5	940	760(778.5)				
	B	440.5	340	—	140	140	12.5	9
		540.5	440	120(138.5)				
		640.5	540	220(238.5)				
		740.5	640	320(338.5)				
		840.5	740	420(438.5)				
		940.5	840	520(538.5)				
		1040.5	940	620(638.5)				
	C	440.5	340	190(211.5)	107	—	12.5	9
		540.5	440	290(311.5)				
		640.5	540	390(411.5)				
		740.5	640	490(511.5)				
		840.5	740	590(611.5)				
		940.5	840	690(711.5)				
		1040.5	940	790(811.5)				
	D	440.5	340	85(104.5)	107	107	12.5	9
		540.5	440	185(204.5)				
		640.5	540	285(304.5)				
		740.5	640	385(404.5)				
		840.5	740	485(504.5)				
		940.5	840	585(604.5)				
		1040.5	940	685(704.5)				

*1 The value in the parentheses represents the maximum stroke.

*2 The strokes for block types B and D are the values when in contact with the inner block.

Code: QZA (with cover)
 Model No. : SKR33/46
 Block type : A/C

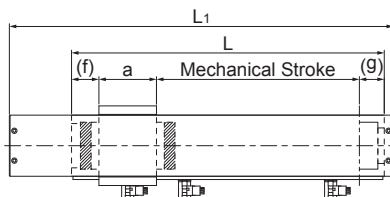

Block type A/C

Unit: mm

Model No.	Block type	Overall length L_1	Outer rail length L	Stroke ^{*1}	a	f	g
SKR33	A (3306) (3310)	220	150	—	54	35	19
		270	200	80(92)			
		370	300	180(192)			
		470	400	280(292)			
		570	500	380(392)			
		670	600	480(492)			
	770	700	580(592)				
	A (3320)	220	150	—	54	45.4	19
		270	200	—			
		370	300	170(181.6)			
		470	400	270(281.6)			
		570	500	370(381.6)			
		670	600	470(481.6)			
	770	700	570(581.6)				
	C	220	150	55(67.5)	28.5	35	19
		270	200	105(117.5)			
		370	300	205(217.5)			
		470	400	305(317.5)			
570		500	405(417.5)				
670		600	505(517.5)				
770	700	605(617.5)					
SKR46	A	440.5	340	175(193.5)	81	42	23.5
		540.5	440	275(293.5)			
		640.5	540	375(393.5)			
		740.5	640	475(493.5)			
		840.5	740	575(593.5)			
		940.5	840	675(693.5)			
	1040.5	940	775(793.5)				
	C	440.5	340	205(226.5)	48	42	23.5
		540.5	440	305(326.5)			
		640.5	540	405(426.5)			
		740.5	640	505(526.5)			
		840.5	740	605(626.5)			
940.5		840	705(726.5)				
1040.5	940	805(826.5)					

Note) Block types B and D cannot be selected for QZA.

*1 The value in the parentheses represents the maximum stroke.

Code: QZA (without cover)
 Model No. : SKR33/46
 Block type : A/C

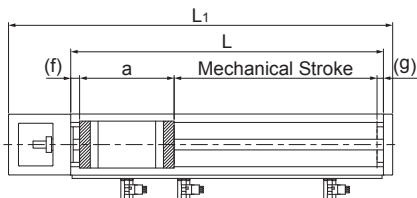

Block type A/C

Unit: mm

Model No.	Block type	Overall length L ₁	Outer rail length L	Stroke ^{*1}	a	f	g
SKR33	A (3306) (3310)	220	150	—	89	11	8
		270	200	80(92)			
		370	300	180(192)			
		470	400	280(292)			
		570	500	380(392)			
		670	600	480(492)			
	770	700	580(592)				
	A (3320)	220	150	—	99.4	11	8
		270	200	—			
		370	300	170(181.6)			
		470	400	270(281.6)			
		570	500	370(381.6)			
		670	600	470(481.6)			
	770	700	570(581.6)				
	C	220	150	55(67.5)	63.5	11	8
		270	200	105(117.5)			
		370	300	205(217.5)			
		470	400	305(317.5)			
570		500	405(417.5)				
670		600	505(517.5)				
770	700	605(617.5)					
SKR46	A	440.5	340	175(193.5)	125	12.5	9
		540.5	440	275(293.5)			
		640.5	540	375(393.5)			
		740.5	640	475(493.5)			
		840.5	740	575(593.5)			
		940.5	840	675(693.5)			
	1040.5	940	775(793.5)				
	C	440.5	340	205(226.5)	92	12.5	9
		540.5	440	305(326.5)			
		640.5	540	405(426.5)			
		740.5	640	505(526.5)			
		840.5	740	605(626.5)			
940.5		840	705(726.5)				
1040.5	940	805(826.5)					

Note) Block types B and D cannot be selected for QZA.

*1 The value in the parentheses represents the maximum stroke.

Code: QZB (with cover)
 Model No. : SKR33/46
 Block type : A/C

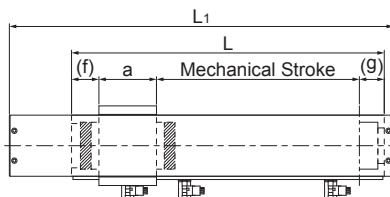

Block type A/C

Unit: mm

Model No.	Block type	Overall length L_1	Outer rail length L	Stroke ^{*1}	a	f	g
SKR33	A (3306) (3310)	220	150	—	54	22	32
		270	200	80(92)			
		370	300	180(192)			
		470	400	280(292)			
		570	500	380(392)			
		670	600	480(492)			
	770	700	580(592)				
	A (3320)	220	150	—	54	22	32
		270	200	80(92)			
		370	300	180(192)			
		470	400	280(292)			
		570	500	380(392)			
		670	600	480(492)			
	770	700	580(592)				
	C	220	150	55(67.5)	28.5	22	32
		270	200	105(117.5)			
		370	300	205(217.5)			
		470	400	305(317.5)			
570		500	405(417.5)				
670		600	505(517.5)				
770	700	605(617.5)					
SKR46	A	440.5	340	175(193.5)	81	27	38.5
		540.5	440	275(293.5)			
		640.5	540	375(393.5)			
		740.5	640	475(493.5)			
		840.5	740	575(593.5)			
		940.5	840	675(693.5)			
	1040.5	940	775(793.5)				
	C	440.5	340	205(226.5)	48	27	38.5
		540.5	440	305(326.5)			
		640.5	540	405(426.5)			
		740.5	640	505(526.5)			
		840.5	740	605(626.5)			
940.5		840	705(726.5)				
1040.5	940	805(826.5)					

Note) Block types B and D cannot be selected for QZB.

*1 The value in the parentheses represents the maximum stroke.

Code: QZB (without cover)
 Model No. : SKR33/46
 Block type : A/C

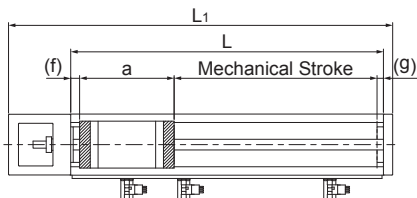

Block type A/C

Unit: mm

Model No.	Block type	Overall length L ₁	Outer rail length L	Stroke ^{*1}	a	f	g
SKR33	A (3306) (3310)	220	150	—	89	11	8
		270	200	80(92)			
		370	300	180(192)			
		470	400	280(292)			
		570	500	380(392)			
		670	600	480(492)			
	770	700	580(592)				
	A (3320)	220	150	—	89	11	8
		270	200	80(92)			
		370	300	180(192)			
		470	400	280(292)			
		570	500	380(392)			
		670	600	480(492)			
	770	700	580(592)				
	C	220	150	55(67.5)	63.5	11	8
		270	200	105(117.5)			
		370	300	205(217.5)			
		470	400	305(317.5)			
570		500	405(417.5)				
670		600	505(517.5)				
SKR46	A	440.5	340	175(193.5)	125	12.5	9
		540.5	440	275(293.5)			
		640.5	540	375(393.5)			
		740.5	640	475(493.5)			
		840.5	740	575(593.5)			
		940.5	840	675(693.5)			
	1040.5	940	775(793.5)				
	C	440.5	340	205(226.5)	92	12.5	9
		540.5	440	305(326.5)			
		640.5	540	405(426.5)			
		740.5	640	505(526.5)			
		840.5	740	605(626.5)			
940.5		840	705(726.5)				
1040.5	940	805(826.5)					

Note) Block types B and D cannot be selected for QZB.

*1 The value in the parentheses represents the maximum stroke.

Code: QZAD (with cover)
 Model No. : SKR33/46
 Block type : B/D

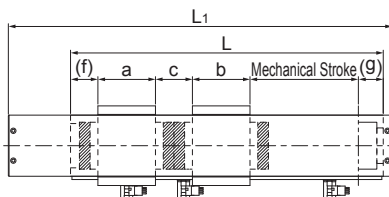

Block type B/D

Unit: mm

Model No.	Block type	Overall length L_1	Outer rail length L	Stroke ^{*1,2}	a	b	C	f	g
SKR33	B (3306) (3310)	220	150	—	54	54	22	35	32
		270	200	—					
		370	300	95(103)					
		470	400	195(203)					
		570	500	295(303)					
		670	600	395(403)					
	770	700	495(503)						
	B (3320)	220	150	—	54	54	22	45.4	32
		270	200	—					
		370	300	80(92.6)					
		470	400	180(192.6)					
		570	500	280(292.6)					
		670	600	380(392.6)					
	770	700	480(492.6)						
	D	220	150	—	28.5	28.5	22	35	32
		270	200	45(54)					
		370	300	145(154)					
		470	400	245(254)					
570		500	345(354)						
670		600	445(454)						
770	700	545(554)							
SKR46	B	440.5	340	—	81	81	29	42	38.5
		540.5	440	150(168.5)					
		640.5	540	250(268.5)					
		740.5	640	350(368.5)					
		840.5	740	450(468.5)					
		940.5	840	550(568.5)					
	1040.5	940	650(668.5)						
	D	440.5	340	115(134.5)	48	48	29	42	38.5
		540.5	440	215(234.5)					
		640.5	540	315(334.5)					
		740.5	640	415(434.5)					
		840.5	740	515(534.5)					
		940.5	840	615(634.5)					
		1040.5	940	715(734.5)					

Note) Block types A and C cannot be selected for QZAD.

*1 The value in the parentheses represents the maximum stroke.

*2 The strokes for block types B and D are the values when in contact with the inner block.

Code: QZAD (without cover)
 Model No. : SKR33/46
 Block type : B/D

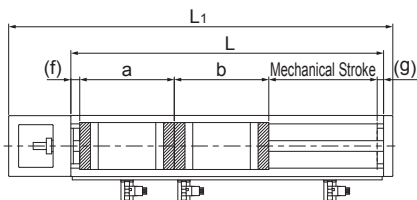

Block type B/D

Unit: mm

Model No.	Block type	Overall length L ₁	Outer rail length L	Stroke ^{*1,2}	a	b	f	g
SKR33	B (3306) (3310)	220	150	—	89	89	11	8
		270	200	—				
		370	300	95(103)				
		470	400	195(203)				
		570	500	295(303)				
		670	600	395(403)				
	770	700	495(503)					
	B (3320)	220	150	—	99.4	89	11	8
		270	200	—				
		370	300	80(92.6)				
		470	400	180(192.6)				
		570	500	280(292.6)				
		670	600	380(392.6)				
	770	700	480(492.6)					
	D	220	150	—	63.5	63.5	11	8
		270	200	45(54)				
		370	300	145(154)				
		470	400	245(254)				
570		500	345(354)					
670		600	445(454)					
770	700	545(554)						
SKR46	B	440.5	340	—	125	125	12.5	9
		540.5	440	150(168.5)				
		640.5	540	250(268.5)				
		740.5	640	350(368.5)				
		840.5	740	450(468.5)				
		940.5	840	550(568.5)				
	1040.5	940	650(668.5)					
	D	440.5	340	115(134.5)	92	92	12.5	9
		540.5	440	215(234.5)				
		640.5	540	315(334.5)				
		740.5	640	415(434.5)				
		840.5	740	515(534.5)				
940.5		840	615(634.5)					
1040.5	940	715(734.5)						

Note) Block types A and C cannot be selected for QZAD.

*1 The value in the parentheses represents the maximum stroke.

*2 The strokes for block types B and D are the values when in contact with the inner block.

Bellows

For model SKR, bellows are available for contamination protection in addition to a cover.

[Model SKR-A (with a Single Long Nut Block)]

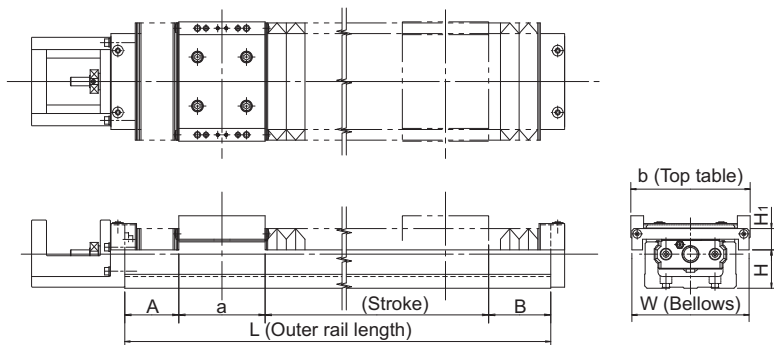

Unit: mm

Model No.	Stroke ¹	Outer rail length L	A	B	a	b	W	H	H ₁
SKR20	20(30.8)	100	18.8	17.2	33.2	52	60	10	20
	55(67.8)	150	25.3	23.7					
	80(93.6)	200	37	36.2					
SKR26	50(60.7)	150	23.7	17.6	47.4	62	74	18	20
	80(91.6)	200	32.8	28.2					
	110(125.6)	250	40.8	36.2					
	160(175.6)	300	40.8	36.2					
SKR33	30(42.8)	150	25.6	27.6	54	86	84	24.5	20
	60(72.8)	200	35.6	37.6					
	140(152.8)	300	45.6	47.6					
	210(222.8)	400	60.6	62.6					
	290(302.8)	500	70.6	72.6					
SKR46	360(372.8)	600	85.6	87.6	81	112	110	36	20
	140(155.8)	340	52.1	51.1					
	210(225.8)	440	67.1	66.1					
	290(305.8)	540	77.1	76.1					
	360(375.8)	640	92.1	91.1					
	440(455.8)	740	102.1	101.1					
510(525.8)	840	117.1	116.1						
590(605.8)	940	127.1	126.1						

*1 The value in the parentheses represents the maximum stroke.

Unit: mm

Model No.	Stroke*1	Outer rail length L	A	B	a	b	W	H	H _i
SKR55 ²	700 (719.6)	980	84.6	80.6	95.2	124	154	37	40
	790 (809.6)	1080	89.6	85.6					
	870 (889.6)	1180	99.6	95.6					
	960 (979.6)	1280	104.6	100.6					
	1050 (1069.6)	1380	109.6	105.6					
SKR65 ²	680 (703.2)	980	85.1	81.7	110	170	184	40	47
	860 (883.2)	1180	95.1	91.7					
	1030 (1053.2)	1380	110.1	106.7					
	1290 (1313.2)	1680	130.1	126.7					

*1 The value in the parentheses represents the maximum stroke.

*2 The bellows for models SKR55 and SKR65 are only suitable for horizontal orientation. If the bellows is to be used in other orientations (vertical or wall-mounted), contact THK.

[Model SKR-B (with Two Long Nut Blocks)]

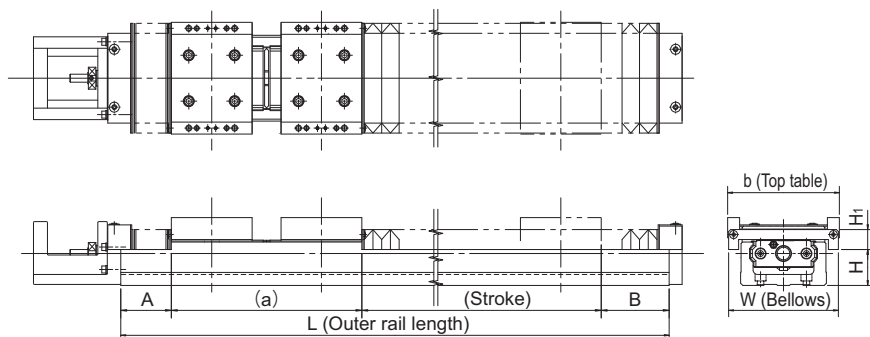

Unit: mm

Model No.	Stroke ^{*1,2}	Outer rail length L	A	B	a	b	W	H	H ₁																																																																																																																				
SKR20	25(34.8)	150	18.8	17.2	79.2	52	60	10	20																																																																																																																				
	60(71.8)	200	25.3	23.7						SKR26	35(46.5)	200	23.7	17.6	111.6	62	74	18	20	65(77.4)	250	32.8	28.2	115(127.4)	300	32.8	28.2	SKR33	80(96.8)	300	35.6	37.6	130	86	84	24.5	20	150(166.8)	400	50.6	52.6	230(246.8)	500	60.6	62.6	300(316.8)	600	75.6	77.6	SKR46	60(75.8)	340	37.1	36.1	191	112	110	36	20	130(145.8)	440	52.1	51.1	210(225.8)	540	62.1	61.1	280(295.8)	640	77.1	76.1	360(375.8)	740	87.1	86.1	430(445.8)	840	102.1	101.1	510(525.8)	940	112.1	111.1	SKR55 ^{*3}	590 (612)	980	74.6	70.6	222.8	124	154	37	40	670 (692)	1080	84.6	80.6	760 (782)	1180	89.6	85.6	850 (872)	1280	94.6	90.6	930 (952)	1380	104.6	100.6	SKR65 ^{*3}	550 (578.6)	980	75.1	71.7	254.6	170	184	40	47	720 (748.6)	1180	90.1	86.7	900 (928.6)	1380
SKR26	35(46.5)	200	23.7	17.6	111.6	62	74	18	20																																																																																																																				
	65(77.4)	250	32.8	28.2																																																																																																																									
	115(127.4)	300	32.8	28.2																																																																																																																									
SKR33	80(96.8)	300	35.6	37.6	130	86	84	24.5	20																																																																																																																				
	150(166.8)	400	50.6	52.6																																																																																																																									
	230(246.8)	500	60.6	62.6																																																																																																																									
	300(316.8)	600	75.6	77.6																																																																																																																									
SKR46	60(75.8)	340	37.1	36.1	191	112	110	36	20																																																																																																																				
	130(145.8)	440	52.1	51.1																																																																																																																									
	210(225.8)	540	62.1	61.1																																																																																																																									
	280(295.8)	640	77.1	76.1																																																																																																																									
	360(375.8)	740	87.1	86.1																																																																																																																									
	430(445.8)	840	102.1	101.1																																																																																																																									
	510(525.8)	940	112.1	111.1																																																																																																																									
SKR55 ^{*3}	590 (612)	980	74.6	70.6	222.8	124	154	37	40																																																																																																																				
	670 (692)	1080	84.6	80.6																																																																																																																									
	760 (782)	1180	89.6	85.6																																																																																																																									
	850 (872)	1280	94.6	90.6																																																																																																																									
	930 (952)	1380	104.6	100.6																																																																																																																									
SKR65 ^{*3}	550 (578.6)	980	75.1	71.7	254.6	170	184	40	47																																																																																																																				
	720 (748.6)	1180	90.1	86.7																																																																																																																									
	900 (928.6)	1380	100.1	96.7																																																																																																																									
	1160 (1188.6)	1680	120.1	116.7																																																																																																																									

*1 The strokes in the table are values when the blocks are in close contact with each other.

*2 The value in the parentheses represents the maximum stroke.

*3 The bellows for models SKR55 and SKR65 are only suitable for horizontal orientation. If the bellows is to be used in other orientations (vertical or wall-mounted), contact THK.

Note) The bellows cannot be attached between the top tables.

[Model SKR-C (with a Single Short Nut Block)]

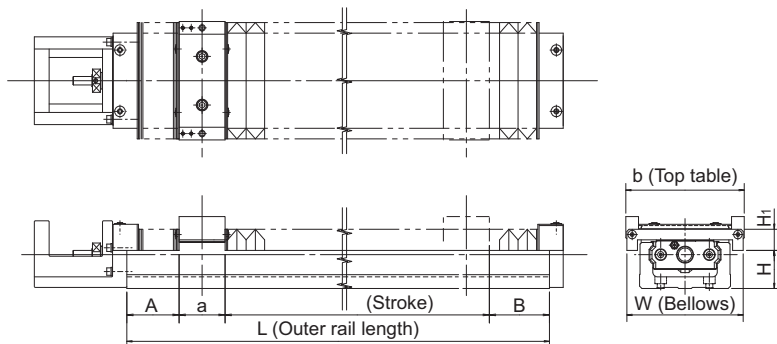

Unit: mm

Model No.	Stroke*	Outer rail length L	A	B	a	b	W	H	H ₁
SKR33	45(58.3)	150	30.6	32.6	28.5	80	80	21.5	17.5
	85(98.3)	200	35.6	37.6					
	155(168.3)	300	50.6	52.6					
	235(248.3)	400	60.6	62.6					
	305(318.3)	500	75.6	77.6					
385(398.3)	600	85.6	87.6						
SKR46	160(178.8)	340	57.1	56.1	48	112	110	36	20
	230(248.8)	440	72.1	71.1					
	310(328.8)	540	82.1	81.1					
	380(398.8)	640	97.1	96.1					
	460(478.8)	740	107.1	106.1					
	530(548.8)	840	122.1	121.1					
610(628.8)	940	132.1	131.1						

*The value in the parentheses represents the maximum stroke.

[Model SKR-D (with Two Short Nut Blocks)]

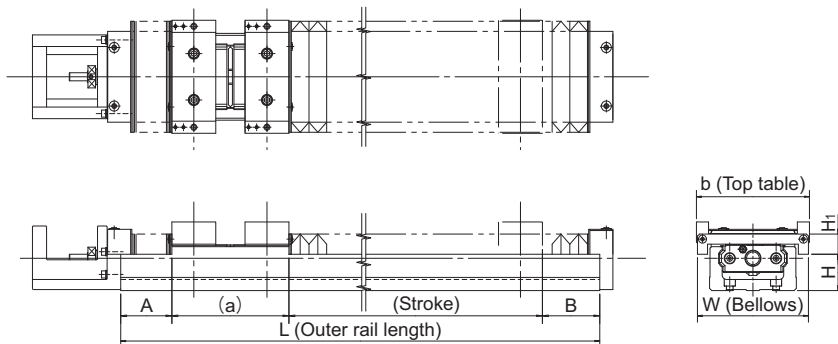

Unit: mm

Model No.	Stroke ^{*1,2}	Outer rail length L	A	B	a	b	W	H	H ₁
SKR33	45(57.8)	200	30.6	32.6	79	86	84	24.5	20
	125(137.8)	300	40.6	42.6					
	195(207.8)	400	55.6	57.6					
	275(287.8)	500	65.6	67.6					
	345(357.8)	600	80.6	82.6					
SKR46	110(121.8)	340	47.1	46.1	125	112	110	36	20
	180(191.8)	440	62.1	61.1					
	260(271.8)	540	72.1	71.1					
	330(341.8)	640	87.1	86.1					
	410(421.8)	740	97.1	96.1					
	480(491.8)	840	112.1	111.1					
560(571.8)	940	122.1	121.1						

*1 The strokes in the table are values when the blocks are in close contact with each other.

*2 The value in the parentheses represents the maximum stroke.

Note) The bellows cannot be attached between the top tables.

Sensor

Optional photo sensors and proximity sensors are available for SKR models.

[Example of Installation]

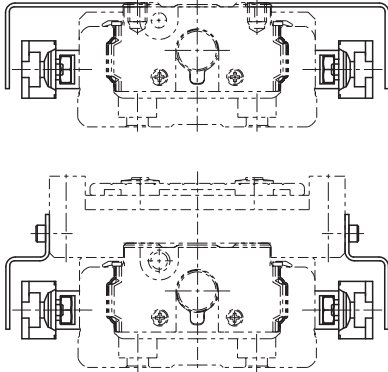

Table15 With/without a sensor

Symbol	Description	Type	Accessory *1
0	None	—	—
1	With sensor rail	—	Mounting screws, sensor rail
2	Photo sensors ^{*2} (3 units)	EE-SX671 (Omron Corp.)	Mounting screw/nut, detecting plate, sensor rail, mounting plate, connector (EE-1001)
6	Photo sensors ^{*2} (3 units)	EE-SX674 (Omron Corp.)	Mounting screw/nut, detecting plate, sensor rail, mounting plate, connector (EE-1001)
7	Proximity sensors N.O. contact (3 units)	APM-D3A1-001 (Azbil Corp.)	Mounting screw/nut, detecting plate, sensor rail
B	Proximity sensors N.C. contact (3 units)	APM-D3B1-003 (Azbil Corp.)	Mounting screw/nut, detecting plate, sensor rail
E	Proximity sensors N.O. contact (1 unit) N.C. contact (2 units)	APM-D3A1-001 APM-D3B1-003 (Azbil Corp.)	Mounting screw/nut, detecting plate, sensor rail
H	Proximity sensors N.O. contact (3 units)	GX-F12A (Panasonic Industrial Devices SUNX Co., Ltd.)	Mounting screw/nut, detecting plate, sensor rail
L	Proximity sensors N.C. contact (3 units)	GX-F12B (Panasonic Industrial Devices SUNX Co., Ltd.)	Mounting screw/nut, detecting plate, sensor rail
J	Proximity sensors N.O. contact (1 unit) N.C. contact (2 units)	GX-F12A GX-F12B (Panasonic Industrial Devices SUNX Co., Ltd.)	Mounting screw/nut, detecting plate, sensor rail
M	Proximity sensors N.O. contact (1 unit) N.C. contact (2 units)	GX-F12A-P GX-F12B-P (Panasonic Industrial Devices SUNX Co., Ltd.)	Mounting screw/nut, detecting plate, sensor rail

N.O. contact: normally open contact

N.C. contact: normally closed contact

*1 If the stroke is less than 70 mm, 2 sensor flags and 2 sensor rails will be included. SKR20 and 26 ship with the sensor rail already installed.

*2 The photo-sensors can be switched between ON when lit and ON when unlit.

[Proximity Sensor]

APM-D3A1-001 (Azbil Corp.)	3 units	GX-F12B (Panasonic Industrial Devices SUNX Co., Ltd.)	3 units
APM-D3B1-003 (Azbil Corp.)	3 units	GX-F12A-P (Panasonic Industrial Devices SUNX Co., Ltd.)	3 units
GX-F12A (Panasonic Industrial Devices SUNX Co., Ltd.)	3 units	GX-F12B-P (Panasonic Industrial Devices SUNX Co., Ltd.)	3 units

● Proximity Sensor: APM-D3A1-001 APM-D3B1-003 (Azbil Corp.)

Unit: mm

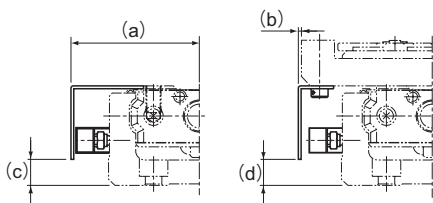

Model No.	a	b	c	d
SKR20	32.5	6.6	6	6
SKR26	37.5	6.4	8	8
SKR33	43	0.3	14.8	15
SKR46	56.2	0.2	26.8	22
SKR55	62.4	0.4	22	22
SKR65	77.4	-7.6	25.1	25

● Proximity sensor GX-F12A GX-F12B GX-F12A-P
GX-F12B-P (Panasonic Industrial Devices SUNX Co., Ltd.)

Unit: mm

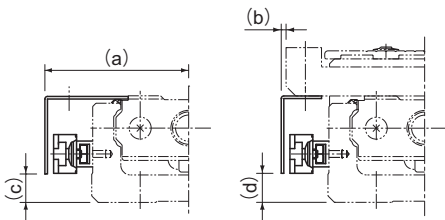

Model No.	a	b	c	d
SKR20	34	8.1	3.6	4
SKR26	39	7.9	6	6
SKR33	44.7	2	13.8	15
SKR46	57.7	1.8	24.8	22
SKR55	64.5	2.5	22	22
SKR65	79	-6	25.1	25

● Proximity Sensor (with Bellows)

Unit: mm

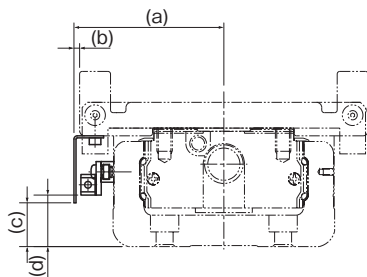

Model No.	a	b	c	d	Sensor type
SKR33	47	4	8	6	GX-F12 (Panasonic Industrial Devices SUNX Co., Ltd.)
SKR46	59.8	3.8	15	15	
SKR33	45.3	2.3	10	11	APM-D3 (Azbil Corp.)
SKR46	56.2	0.2	22	25	

[Photo Sensor]

EE-SX671 (Omron Corp.) 3 units

EE-SX674 (Omron Corp.) 3 units

Connector EE-1001 (Omron Corp.) 3 units

(Note) The connector is an appended article.

● **Photo Sensor: EE-SX671 (Omron Corp.)**

Unit: mm

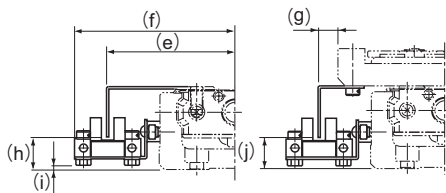

Model No.	e	f	g	h	i	j
SKR20	41	53.8	15	9.4	0.9	9.5
SKR26	45.9	58.7	14.9	11.4	2.9	11.5
SKR33	51.1	63.6	8.3	18.8	7.4	19.5
SKR46	64.1	76.6	8.3	29.8	16.4	26.5
SKR55	70.7	83.5	8.6	24.5	13.6	25
SKR65	85.5	98.5	0.6	28.1	16.6	28

● **Photo Sensor: EE-SX674 (Omron Corp.)**

Unit: mm

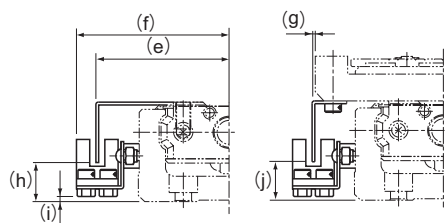

Model No.	e	f	g	h	i	j
SKR20	38.3	44.8	12.5	10.9	0.6	11
SKR26	43.3	49.7	12.5	12.9	2.6	13
SKR33	45.9	52.1	3.3	17.8	7.1	20
SKR46	58.9	65.1	3.2	28.8	16.1	27
SKR55	63.5	70.5	1.5	24.5	13.1	24
SKR65	79	85.5	-6	28.6	16.1	28

● **Photo Sensor (with Bellows)**

Unit: mm

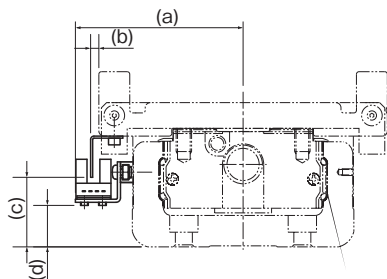

Model No.	a	b	c	d	Sensor type
SKR33	63.6	8.3	19.5	7.4	EE-SX671 (Omron Corp.)
SKR46	76.6	8.3	26.5	16.4	
SKR33	52.1	3.3	18	5.1	EE-SX674 (Omron Corp.)
SKR46	65.1	3.2	27	16.1	

[Sensor Rail]

The sensor rail can be attached alone.

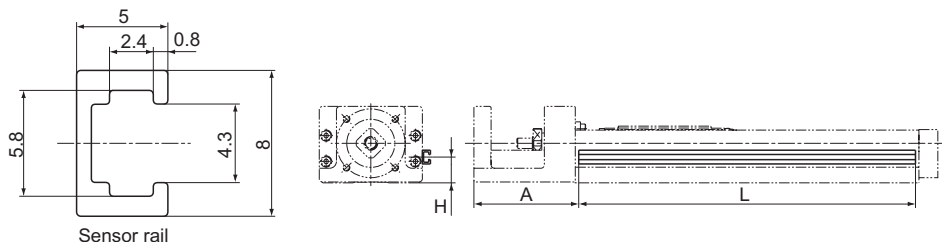

Sensor rail

Unit: mm

Model No.	Stroke*	Outer rail length	H	A	L
SKR20	30	100	10	43	111
	80	150			161
	130	200			211
SKR26	60	150	12	54	161
	110	200			211
	160	250			261
	210	300			311
SKR33	45	150	20	61	146
	95	200			196
	195	300			296
	295	400			396
	395	500			496
	495	600			596
SKR46	190	340	29	89.5	336
	290	440			436
	390	540			536
	490	640			636
	590	740			736
	690	840			836
SKR55	790	940	27	96	936
	800	980			976
	900	1080			1076
	1000	1180			1176
	1100	1280			1276
SKR65	1200	1380	30	102	1376
	790	980			976
	990	1180			1176
	1190	1380			1376
	1490	1680			1676

*Indicates stroke length when one long-type inner block is incorporated.

Intermediate Flange (Direct Coupling)

[Motors Used and Applicable Intermediate Flanges for Model SKR]

Several types of intermediate flanges for mounting motors are available for model SKR. Specify an intermediate flange that matches the motor used.

Each intermediate flange is made of steel and provided with THK AP-C treatment, a surface treatment that provides excellent corrosion resistance.

Table16 Table of Motors Used and Corresponding Housing A and Intermediate Flanges

Motor type		Rated output	Flange size	SKR							
				SKR20	SKR26	SKR33	SKR46	SKR55	SKR65		
AC servo motor	Σ-V mini	SGMMV-A1	10 W	□25	AN	AN	—	—	—	—	
		SGMMV-A2	20 W		AN	AN	—	—	—	—	
		SGMMV-A3	30 W		AN	AN	—	—	—	—	
		Σ-V	SGMJV-A5	50 W	□40	AQ	AQ	AQ	—	—	—
			SGMAV-A5			AQ	AQ	AQ	—	—	—
			SGMJV-01	100 W	□40	—	—	AQ	—	—	—
			SGMAV-01			—	—	AQ	—	—	—
			SGMJV-C2			150 W	—	—	AQ	—	—
			SGMJV-02	200 W	□60	—	—	—	AV	A0	AV
	SGMAV-02		—			—	—	AV	A0	AV	
	SGMJV-04		400 W	□60	—	—	—	AV	A0	AV	
	SGMAV-04				—	—	—	AV	A0	AV	
	SGMJV-06	600 W			—	—	—	AV	A0	AV	
	SGMJV-08	750 W	□80	—	—	—	—	AZ	AZ		
	SGMAV-08			—	—	—	—	AZ	AZ		
	Σ-7	SGM7J-A5	50 W	□40	AQ	AQ	AQ	—	—	—	
		SGM7A-A5			AQ	AQ	AQ	—	—	—	
		SGM7J-01	100 W	□40	—	—	AQ	—	—	—	
		SGM7A-01			—	—	AQ	—	—	—	
		SGM7J-C2			150 W	—	—	AQ	—	—	—
		SGM7J-02	200 W	□60	—	—	—	AV	A0	AV	
		SGM7A-02			—	—	—	AV	A0	AV	
		SGM7J-04	400 W	□60	—	—	—	AV	A0	AV	
		SGM7A-04			—	—	—	AV	A0	AV	
		SGM7J-06			600 W	—	—	—	AV	A0	AV
		SGM7J-08	750 W	□80	—	—	—	—	AZ	AZ	
	SGM7A-08	—			—	—	—	AZ	AZ		

Motor type		Rated output	Flange size	SKR									
				SKR20	SKR26	SKR33	SKR46	SKR55	SKR65				
AC servo motor	Yaskawa Electric	Σ-X	SGMXJ-A5	50 W	□40	AQ	AQ	AQ	—	—	—		
						SGMXA-A5	AQ	AQ	AQ	—	—	—	
			SGMXJ-01	100 W		—	—	AQ	—	—	—		
			SGMXA-01			—	—	AQ	—	—	—		
			SGMXJ-C2	150 W		—	—	AQ	—	—	—		
			SGMXA-C2			—	—	AQ	—	—	—		
		SGMXJ-02	200 W	—	—	—	AV	A0	AV				
		SGMXA-02		—	—	—	AV	A0	AV				
		SGMXJ-04	400 W	—	—	—	AV	A0	AV				
		SGMXA-04		—	—	—	AV	A0	AV				
		SGMXJ-06	600 W	—	—	—	AV	A0	AV				
		SGMXA-06		—	—	—	AV	A0	AV				
		SGMXJ-08	750 W	—	—	—	—	AZ	AZ				
		SGMXA-08		—	—	—	—	AZ	AZ				
	Mitsubishi Electric	MELSERVO	J4	HG-AK0136	10 W	□25	AN	AN	—	—	—	—	
				HG-AK0236	20 W		AN	AN	—	—	—	—	
				HG-AK0336	30 W		AN	AN	—	—	—	—	
				HG-MR053	50 W		□40	AQ	AQ	AQ	—	—	—
				HG-KR053			AQ	AQ	AQ	—	—	—	
				HG-MR13	100 W		□40	—	—	AQ	—	—	—
			HG-KR13	—		—	AQ	—	—	—			
			HG-MR23	200 W	□60	—	—	—	AV	A0	AV		
			HG-KR23			—	—	—	AV	A0	AV		
			HG-MR43	400 W	□60	—	—	—	AV	A0	AV		
			HG-KR43			—	—	—	AV	A0	AV		
			HG-MR73	750 W	□80	—	—	—	—	AZ	AZ		
			HG-KR73			—	—	—	—	AZ	AZ		
			J5	HK-KT053W	50 W	□40	AQ	AQ	AQ	—	—	—	
		HK-KT13W		100 W	—		—	AQ	—	—	—		
		HK-KT23W		200 W	□60	—	—	—	AV	A0	AV		
		HK-KT43W		400 W		—	—	—	AV	A0	AV		
		HK-KT7M3W		750 W	□80	—	—	—	—	AZ	AZ		
		JN		HF-KN053	50 W	□40	AQ	AQ	AQ	—	—	—	
HF-KN13				100 W	—		—	AQ	—	—	—		
HF-KN23				200 W	□60	—	—	—	AV	A0	AV		
HF-KN43				400 W		—	—	—	AV	A0	AV		
Tamagawa Seiki Co., Ltd.		TBL-II		TS4602	50 W	□40	AQ	AQ	AQ	—	—	—	
				TS4603	100 W		—	—	AQ	—	—	—	
				TS4604	150 W		—	—	AQ	—	—	—	
			TS4607	200 W	□60		—	—	—	AV	A0	AV	
	TS4609		400 W	□60	—		—	—	AV	A0	AV		
	TS4614		750 W	□80	—		—	—	—	AZ	AZ		
	TBL-IV	TSM3102	50 W	□40	AQ	AQ	AQ	—	—	—			
		TSM3104	100 W		—	—	AQ	—	—	—			
		TSM3202	200 W	□60	—	—	—	AV	A0	AV			
		TSM3204	400 W		—	—	—	AV	A0	AV			
		TSM3303	600 W	□80	—	—	—	—	AZ	AZ			
		TSM3304	750 W		—	—	—	—	AZ	AZ			

Motor type				Rated output	Flange size	SKR						
						SKR20	SKR26	SKR33	SKR46	SKR55	SKR65	
AC servo motor	Panasonic Corp.	MINAS	A5	MSMD5A	50 W	□38	AP	AP	AP	—	—	—
				MSME5A			AP	AP	AP	—	—	—
				MSMD01	100 W		—	—	AP	—	—	—
				MSME01			—	—	AP	—	—	—
				MSMD02			200 W	—	—	—	AY	—
			MSME02	—	—	—		AY	—	—		
			MSMD04	400 W	□60	—	—	—	AY	—	—	
			MSME04			—	—	—	AY	—	—	
			MSMD08	750 W		□80	—	—	—	—	A5	A5
		MSME08	—				—	—	—	A5	A5	
		MSMF5A	50 W				□38	AP	AP	AP	—	—
		MHMF5A		□40	AQ		AQ	AQ	—	—	—	
		MSMF01	100 W	□38	—		—	AP	—	—	—	
		MHMF01		□40	—	—	AQ	—	—	—		
		MSMF02	200 W	□60	—	—	—	AY	—	—		
		MHMF02			—	—	—	AY	—	—		
		MSMF04	400 W		—	—	—	AY	—	—		
		MHMF04			—	—	—	AY	—	—		
	MSMF08	750 W	□80		—	—	—	—	A5	A5		
	MHMF08			—	—	—	—	A5	A5			
	Keyence Corporation	SV		SV-M005	50 W	□40	AQ	AQ	AQ	—	—	—
				SV-M010	100 W		—	—	AQ	—	—	—
				SV-M020	200 W		□60	—	—	—	AV	A0
			SV-M040	400 W	—	—		—	AV	A0	AV	
			SV-M075	750 W	□80	—		—	—	—	AZ	AZ
			SV2	SV2-M005	50 W	□40	AQ	AQ	AQ	—	—	—
		SV2-M010		100 W	—		—	AQ	—	—	—	
		SV2-M020		200 W	□60		—	—	—	AV	A0	AV
		SV2-M040		400 W		—	—	—	AV	A0	AV	
		SV2-M075		750 W		□80	—	—	—	—	AZ	AZ
SANYO DENKI		SANMOTION R		R2□A04005	50 W	□40	AQ	AQ	AQ	—	—	—
			R2EA04008	80 W	—		—	AQ	—	—	—	
	R2□A04010		100 W	—	—		AQ	—	—	—		
	R2□A06020		200 W	□60	—	—	—	AV	A0	AV		
	R2AA06040		400 W		—	—	—	AV	A0	AV		
	R2AA08075		750 W		□80	—	—	—	—	AZ	AZ	
Omron	OMNUC G5	R88M-K05030	50 W	□40	AQ	AQ	AQ	—	—	—		
		R88M-K10030	100 W		—	—	AQ	—	—	—		
		R88M-K20030	200 W		□60	—	—	—	AY	—	—	
		R88M-K40030	400 W	—		—	—	AY	—	—		
		R88M-K75030	750 W	□80		—	—	—	—	A5	A5	
	1S	R88M-1M10030	100 W	□40	—	—	AQ	—	—	—		
		R88M-1M20030	200 W	□60	—	—	—	AY	—	—		
		R88M-1M40030	400 W		—	—	—	AY	—	—		
		R88M-1M75030	750 W	□80	—	—	—	—	A5	A5		
Fanuc	β is series	βis0.2/5000	50 W	□40	AQ	AQ	AQ	—	—	—		
		βis0.3/5000	100 W		—	—	AQ	—	—	—		

		Motor type		Flange size	SKR							
					SKR20	SKR26	SKR33	SKR46	SKR55	SKR65		
Stepping motor	Oriental Motor	α Step	AZ2 *, AR2 *	□28	AS	AS	—	—	—	—		
			AZ4 *, AR4 *	□42	AR	AR	AR	—	—	—		
			AZM48	□42	AR	AR	AR	—	—	—		
			AZ6 *, AR6 *	□60	—	—	AU	AU	—	—		
			AZ9 *, AR9 *	□85	—	—	—	—	A6	A6		
		5 phase	CRK	CRK52 *	□28	AS	AS	—	—	—	—	
				CRK54 *	□42	AR	AR	AR	—	—	—	
				CRK56 *	□60	—	—	AU	AU	—	—	
			RK II	RKS54 *	□42	AR	AR	AR	—	—	—	
				RKS56 *	□60	—	—	AU	AU	—	—	
				RKS59 *	□85	—	—	—	—	A6	A6	
				PKP	PKP52 *	□28	AS	AS	—	—	—	—
					PKP54 *	□42	AR	AR	AR	—	—	—
					PKP56 *	□56.4	—	—	AT	—	—	—
					PKP56 *	□60	—	—	AU	AU	—	—
	2 phase	PKP/CVD	PKP22 *	□28	AS	AS	—	—	—			
			PKP24 *	□42	AR	AR	AR	—	—			
			PKP26 *	□56.4	—	—	AT	—	—			
	SANYO DENKI	PB	PBDM28 *	□28	AS	AS	—	—	—			
			PBDM423, PBA * * 423	□42	AR	AR	AR	—	—			
			PBDM60 *, PBA * * 60 *	□60	—	—	AU	AU	—			
		5-phase	FAF/FDF52 *	□28	AS	AS	—	—	—			
			FAF54 */FDF54 */ FA511M42/FB511M42	□42	AR	AR	AR	—	—			
			FAM56 */FDM56 */ FA512M60/FB512M60	□60	—	—	AU	AU	—			
		2-phase	D * 14S28 *	□28	AS	AS	—	—	—			
			DB14H52 *	□42	AR	AR	AR	—	—			
					AR	AR	AR	—	—			
D * 16H71 *			□56	—	—	AT	—	—				
DB16H78 *			□60	—	—	AU	AU	—				
Keyence Corporation		2-phase	QS-M28	□28	AS	AS	—	—	—			
	QS-M42		□42	AR	AR	AR	—	—				
	QS-M60		□60	—	—	AU	AU	—				

Note 1) The symbols in the table indicate the housing A and intermediate flange.

Note 2) For motor couplings, contact THK.

Note 3) The motor types in the table represent only some of the types available. For details regarding different types, please see the catalog from each respective motor manufacturer.

Intermediate Flange (Motor Wrap)

[Motors Used and Applicable Intermediate Flanges for Model SKR]

Several types of intermediate flanges for mounting motors are available.

In model coding 7, "With/without motor," specify an intermediate flange that matches the motor used: R1, R2, R3, R4, R5, or R6.

Symbol Coding

Wrap symbol ①	Intermediate flange ②	Motor shaft diameter (mm) ③	Motor shaft securing method ④
W	Q	08	D
W	Please refer to "Motors Used and Corresponding Housing A and Intermediate Flanges" below.	Please specify a motor shaft diameter. (Please refer to "Motors Used and Corresponding Housing A and Intermediate Flanges" below.)	K: Key D: Flat M: Friction fastener

Motor shaft securing method

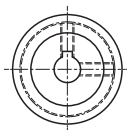

Key

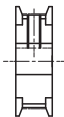

Flat

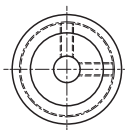

Friction fastener

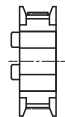

Table17 Table of Motors Used and Corresponding Housing A and Intermediate Flanges

Motor type		Rated output	Flange size	SKR							
				SKR20	SKR26	SKR33	SKR46	SKR55	SKR65		
AC servo motor	Σ-V mini	SGMMV-A1	10 W	□25	WN-05D	WN-05D	—	—	—	—	
		SGMMV-A2	20 W		WN-05D	WN-05D	—	—	—	—	
		SGMMV-A3	30 W		WN-05D	WN-05D	—	—	—	—	
	Σ-V	SGMJV-A5	50 W	□40	WQ-08K	WQ-08K	WQ-08K WQ-08M	—	—	—	
					SGMAV-A5	WQ-08K	WQ-08K	WQ-08K WQ-08M	—	—	—
		SGMJV-01	100 W		—	—	WQ-08K WQ-08M	—	—	—	
					SGMAV-01	—	—	WQ-08K WQ-08M	—	—	—
		SGMJV-C2	150 W		—	—	WQ-08K WQ-08M	—	—	—	
					SGMJV-02	200 W	—	—	—	WV-14M	WV-14M
		SGMAV-02	—		—		—	WV-14M	WV-14M	WV-14M	
		SGMJV-04	400 W		□60	—	—	—	WV-14M	WV-14M	WV-14M
						SGMAV-04	—	—	—	WV-14M	WV-14M
		SGMJV-06	600 W			—	—	—	—	WV-14M	WV-14M
						SGMJV-08	750 W	—	—	—	WZ-19M
		SGMAV-08	—			—		—	WZ-19M	WZ-19M	

Motor type		Rated output	Flange size	SKR						
				SKR20	SKR26	SKR33	SKR46	SKR55	SKR65	
AC servo motor	Yaskawa Electric	Σ -7	50 W	<input type="checkbox"/> 40	WQ-08K	WQ-08K	WQ-08K WQ-08M	—	—	—
					WQ-08K	WQ-08K	WQ-08K WQ-08M	—	—	—
			100 W		—	—	WQ-08K WQ-08M	—	—	—
			SGM7A-01		—	—	WQ-08K WQ-08M	—	—	—
			150 W		—	—	WQ-08K WQ-08M	—	—	—
			SGM7J-C2		—	—	WQ-08K WQ-08M	—	—	—
		200 W	<input type="checkbox"/> 60	—	—	—	WV-14M	WV-14M	WV-14M	
		SGM7A-02		—	—	—	WV-14M	WV-14M	WV-14M	
		400 W		—	—	—	WV-14M	WV-14M	WV-14M	
		SGM7A-04		—	—	—	WV-14M	WV-14M	WV-14M	
		600 W	<input type="checkbox"/> 80	—	—	—	—	WV-14M	WV-14M	
		SGM7J-06		—	—	—	—	WV-14M	WV-14M	
		750 W		—	—	—	—	WZ-19M	WZ-19M	
		SGM7A-08		—	—	—	—	WZ-19M	WZ-19M	
	Σ -X	SGMXJ-A5	50 W	<input type="checkbox"/> 40	WQ-08K	WQ-08K	WQ-08K WQ-08M	—	—	—
					SGMXA-A5	WQ-08K	WQ-08K	WQ-08K WQ-08M	—	—
			100 W		—	—	WQ-08K WQ-08M	—	—	—
			SGMXA-01		—	—	WQ-08K WQ-08M	—	—	—
			150 W		—	—	WQ-08K WQ-08M	—	—	—
			SGMXA-C2		—	—	WQ-08K WQ-08M	—	—	—
200 W		<input type="checkbox"/> 60	—	—	—	WV-14M	WV-14M	WV-14M		
SGMXA-02			—	—	—	WV-14M	WV-14M	WV-14M		
400 W			—	—	—	WV-14M	WV-14M	WV-14M		
SGMXA-04			—	—	—	WV-14M	WV-14M	WV-14M		
600 W		<input type="checkbox"/> 80	—	—	—	—	WV-14M	WV-14M		
SGMXJ-06			—	—	—	—	WV-14M	WV-14M		
750 W			—	—	—	—	WZ-19M	WZ-19M		
SGMXA-06			—	—	—	—	WZ-19M	WZ-19M		
SGMXJ-08	—	—	—	—	WZ-19M	WZ-19M				
SGMXA-08	—	—	—	—	WZ-19M	WZ-19M				

Motor type		Rated output	Flange size	SKR								
				SKR20	SKR26	SKR33	SKR46	SKR55	SKR65			
AC servo motor	Mitsubishi Electric	MELSERVO	J4	HG-AK0136	10 W	□25	WN-05D	WN-05D	—	—	—	—
				HG-AK0236	20 W		WN-05D	WN-05D	—	—	—	—
				HG-AK0336	30 W		WN-05D	WN-05D	—	—	—	—
			HG-MR053	50 W	□40	WQ-08D	WQ-08D	—	—	—	—	
			HG-KR053			WQ-08D	WQ-08D	—	—	—	—	
			HG-MR13	100 W		—	—	WQ-08D WQ-08M	—	—	—	
			HG-KR13		—	—	WQ-08D WQ-08M	—	—	—		
			HG-MR23	200 W	□60	—	—	—	WV-14M	WV-14M	WV-14M	
			HG-KR23			—	—	—	WV-14M	WV-14M	WV-14M	
		HG-MR43	400 W	—		—	—	WV-14M	WV-14M	WV-14M		
		HG-KR43		—	—	—	WV-14M	WV-14M	WV-14M			
		HG-MR73	750 W	□80	—	—	—	—	WZ-19M	WZ-19M		
		HG-KR73			—	—	—	—	WZ-19M	WZ-19M		
		J5	HK-KT053W	50 W	□40	WQ-08D	WQ-08D	WQ-08D WQ-08M	—	—	—	
			HK-KT13W	100 W		—	—	WQ-08D WQ-08M	—	—	—	
			HK-KT23W	200 W	□60	—	—	—	WV-14M	WV-14M	WV-14M	
			HK-KT43W	400 W		—	—	—	WV-14M	WV-14M	WV-14M	
			HK-KT7M3W	750 W	□80	—	—	—	—	WZ-19M	WZ-19M	
	JN		HF-KN053	50 W	□40	WQ-08D	WQ-08D	WQ-08D WQ-08M	—	—	—	
			HF-KN13	100 W		—	—	WQ-08D WQ-08M	—	—	—	
			HF-KN23	200 W	□60	—	—	—	WV-14M	WV-14M	WV-14M	
			HF-KN43	400 W		—	—	—	WV-14M	WV-14M	WV-14M	
	Tamagawa Seiki Co., Ltd.	TBL-i II	TS4602	50 W	□40	WQ-08D	WQ-08D	WQ-08D WQ-08M	—	—	—	
			TS4603	100 W		—	—	WQ-08D WQ-08M	—	—	—	
			TS4604	150 W		—	—	WQ-08D WQ-08M	—	—	—	
			TS4607	200 W	□60	—	—	—	WV-14M	WV-14M	WV-14M	
			TS4609	400 W		—	—	—	WV-14M	WV-14M	WV-14M	
			TS4614	750 W	□80	—	—	—	—	WZ-19M	WZ-19M	
TBL-i IV		TSM3102	50 W	□40	WQ-08D	WQ-08D	WQ-08D WQ-08M	—	—	—		
		TSM3104	100 W		—	—	WQ-08D WQ-08M	—	—	—		
		TSM3202	200 W	□60	—	—	—	WV-14M	WV-14M	WV-14M		
		TSM3204	400 W		—	—	—	WV-14M	WV-14M	WV-14M		
		TSM3303	600 W	□80	—	—	—	—	WZ-19M	WZ-19M		
		TSM3304	750 W		—	—	—	—	WZ-19M	WZ-19M		

Motor type				Rated output	Flange size	SKR						
						SKR20	SKR26	SKR33	SKR46	SKR55	SKR65	
AC servo motor	Panasonic Corp.	MINAS	A5	MSMD5A	50 W	□38	WP-08D WP-08K	WP-08D WP-08K	WP-08D WP-08K WP-08M	—	—	—
				MSME5A			WP-08D WP-08K	WP-08D WP-08K	WP-08D WP-08K WP-08M	—	—	—
				MSMD01	100 W		—	—	WP-08D WP-08K WP-08M	—	—	—
				MSME01			—	—	WP-08D WP-08K WP-08M	—	—	—
			MSMD02	200 W	□60	—	—	—	WY-11M	—	—	
			MSME02			—	—	—	WY-11M	—	—	
			MSMD04	400 W	□60	—	—	—	WY-14M	—	—	
			MSME04			—	—	—	WY-14M	—	—	
			MSMD08	750 W	□80	—	—	—	—	W5-19M	W5-19M	
			MSME08			—	—	—	—	W5-19M	W5-19M	
			A6	MSMF5A	50 W	□38	WP-08K	WP-08K	WP-08K WP-08M	—	—	—
				MHMF5A		□40	WQ-08K	WQ-08K	WQ-08K WQ-08M	—	—	—
				MSMF01	100 W	□38	—	—	WP-08K WP-08M	—	—	—
				MHMF01		□40	—	—	WQ-08K WQ-08M	—	—	—
		MSMF02		200 W	□60	—	—	—	WY-11M	—	—	
		MHMF02				—	—	—	WY-11M	—	—	
		MSMF04		400 W	□60	—	—	—	WY-14M	—	—	
		MHMF04				—	—	—	WY-14M	—	—	
		MSMF08	750 W	□80	—	—	—	—	W5-19M	W5-19M		
		MHMF08			—	—	—	—	W5-19M	W5-19M		
Keyence Corporation	SV	SV-M005	50 W	□40	WQ-08K	WQ-08K	WQ-08K WQ-08M	—	—	—		
		SV-M010			100 W	—	—	WQ-08K WQ-08M	—	—	—	
		SV-M020	200 W	□60	—	—	—	WV-14M	WV-14M	WV-14M		
		SV-M040	400 W		—	—	—	WV-14M	WV-14M	WV-14M		
		SV-M075	750 W	□80	—	—	—	—	WZ-19M	WZ-19M		
	SV2	SV2-M005	50 W	□40	WQ-08K	WQ-08K	WQ-08K WQ-08M	—	—	—		
		SV2-M010			100 W	—	—	WQ-08K WQ-08M	—	—	—	
		SV2-M020	200 W	□60	—	—	—	WV-14M	WV-14M	WV-14M		
		SV2-M040	400 W		—	—	—	WV-14M	WV-14M	WV-14M		
		SV2-M075	750 W	□80	—	—	—	—	WZ-19M	WZ-19M		

Motor type		Rated output	Flange size	SKR								
				SKR20	SKR26	SKR33	SKR46	SKR55	SKR65			
AC servo motor	SANYO DENKI	SANMOTION R	R2□A04005	50 W	□40	WQ-08K	WQ-08K	WQ-08M	—	—	—	
			R2EA04008	80 W		—	—	WQ-08M	—	—	—	
			R2□A04010	100 W		—	—	WQ-08M	—	—	—	
			R2□A06020	200 W	□60	—	—	—	WV-14M	WV-14M	WV-14M	
			R2AA06040	400 W		—	—	—	WV-14M	WV-14M	WV-14M	
			R2AA08075	750 W		□80	—	—	—	—	WZ-16M	WZ-16M
	Omron	OMNIUC G5	R88M-K05030	50 W	□40	WQ-08K	WQ-08K	WQ-08K WQ-08M	—	—	—	
			R88M-K10030	100 W		—	—	WQ-08K WQ-08M	—	—	—	
			R88M-K20030	200 W		□60	—	—	—	WY-11M	—	—
			R88M-K40030	400 W	—		—	—	WY-14M	—	—	
			R88M-K75030	750 W	□80		—	—	—	—	W5-19M	W5-19M
			1S	R88M-1M10030	100 W	□40	—	—	WQ-08K WQ-08M	—	—	—
		R88M-1M20030		200 W	—		—	—	WY-11M	—	—	
		R88M-1M40030		400 W	□60		—	—	—	WY-14M	—	—
		R88M-1M75030		750 W		□80	—	—	—	—	W5-19M	W5-19M
		Fanuc		β is series	βis0.2/5000	50 W	□40	WQ-08K	WQ-08K	—	—	—

Note 1) The symbols in the table indicate the housing A and intermediate flange.

Note 2) For motor couplings, contact THK.

Note 3) The motor types in the table represent only some of the types available. For details regarding different types, please see the catalog from each respective motor manufacturer.

[Dimensional Drawing of Housing A/Intermediate Flange for Model SKR]

● For Model SKR20

SKR**	··· Actuator model number
● ◇	··· ●: Housing A ◇: Intermediate flange

■ Housing A

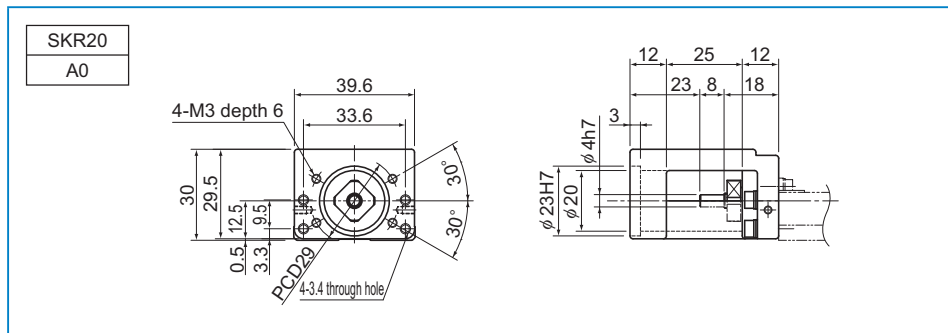

■ Intermediate Flange

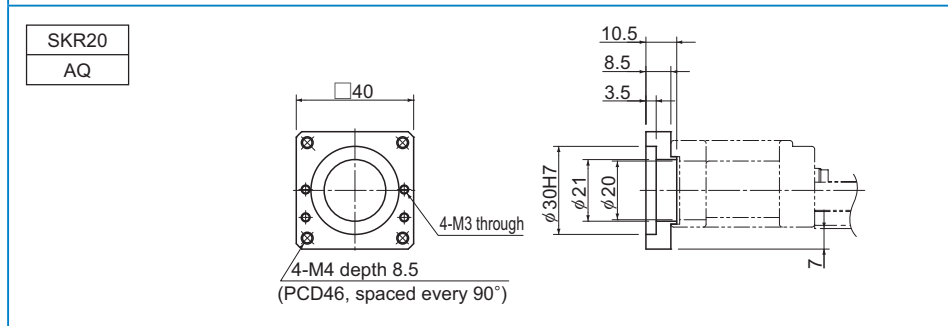
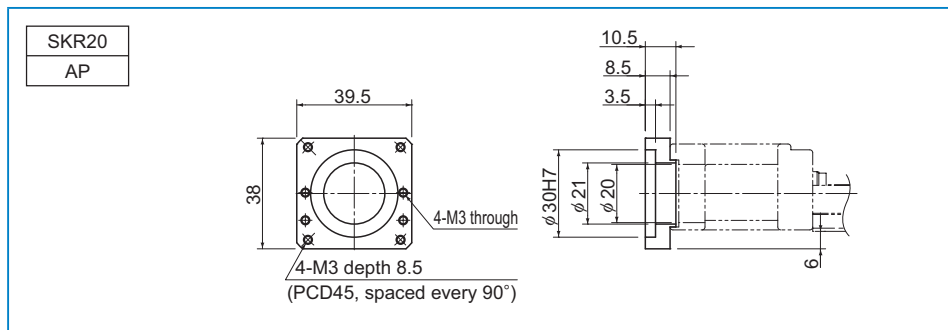

SKR20

AR

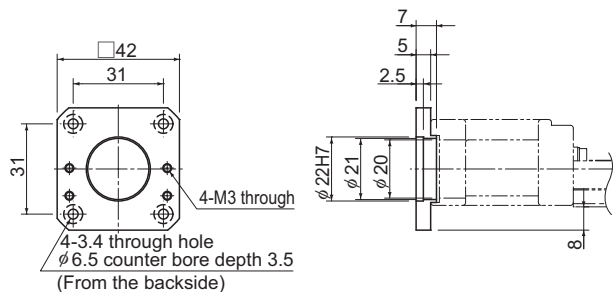

SKR20

AS

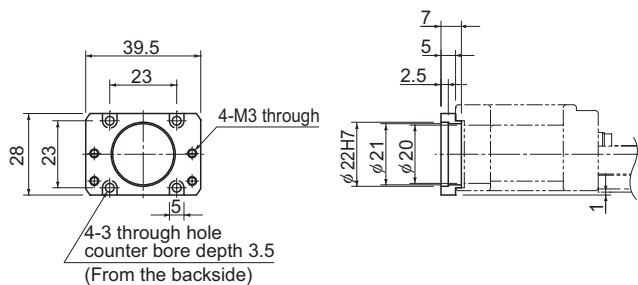

SKR20

AN

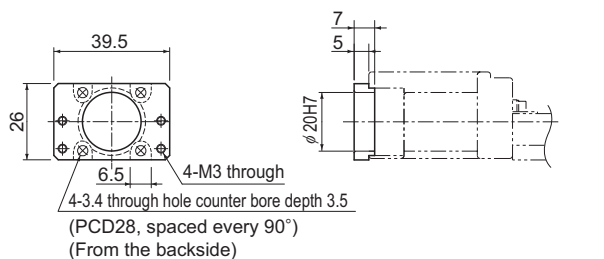

Motor Wrap Housing A

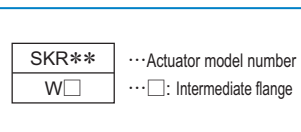
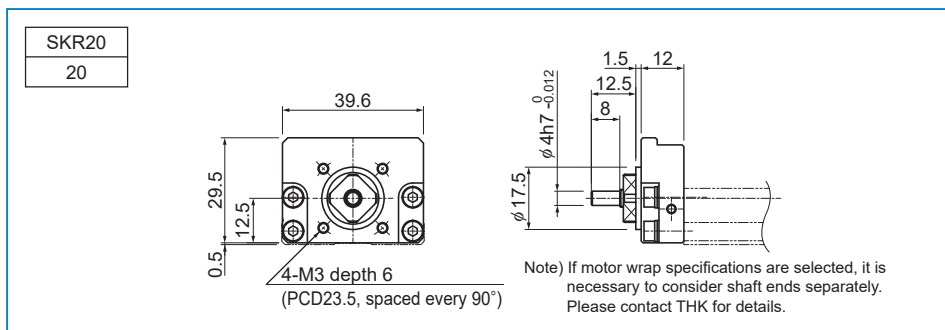

Motor Wrap Specifications (Intermediate Flange)

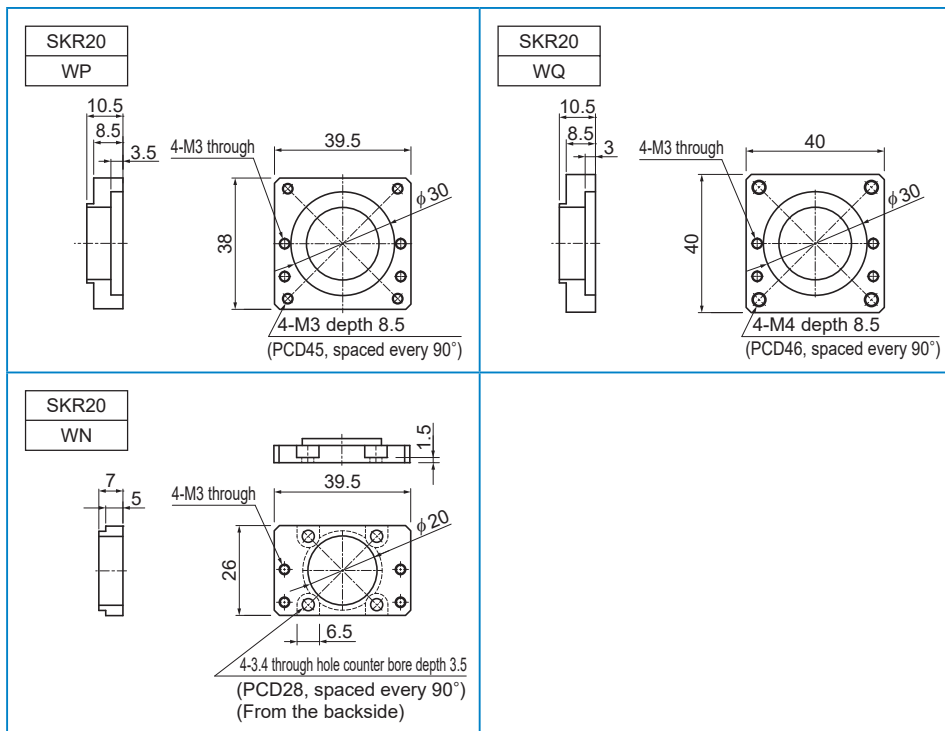

● For Model SKR26

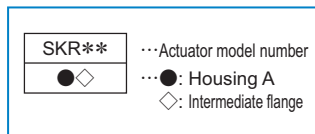

■ Housing A

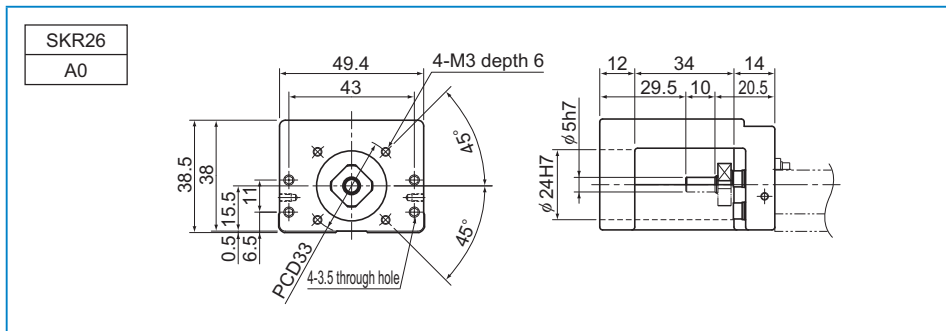

■ Intermediate Flange

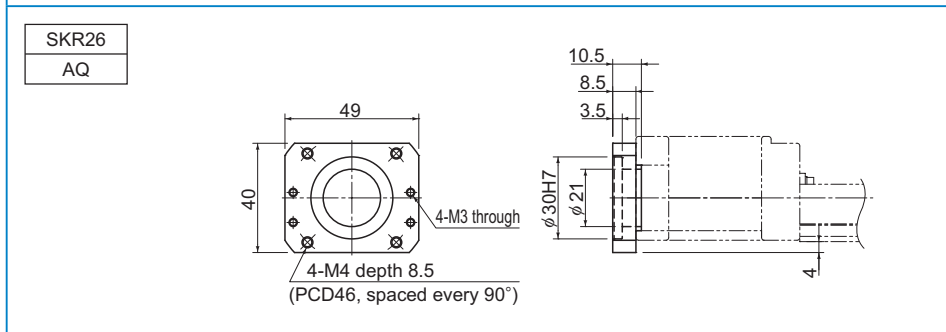
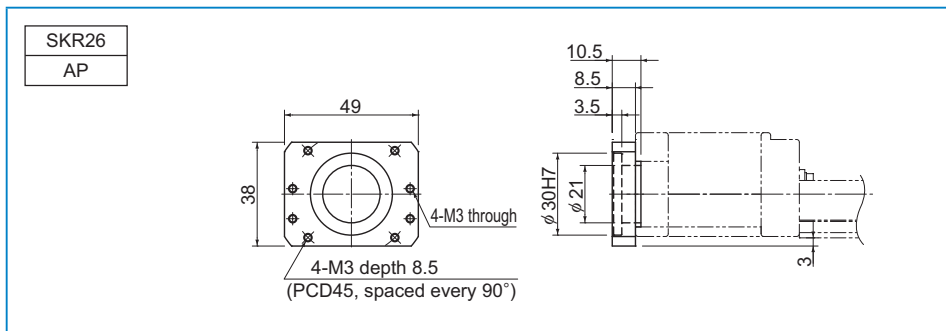

SKR26

AR

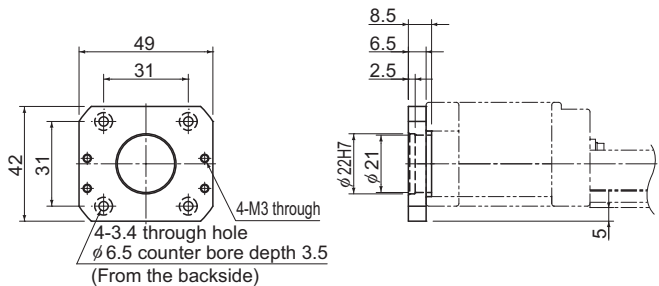

SKR26

AS

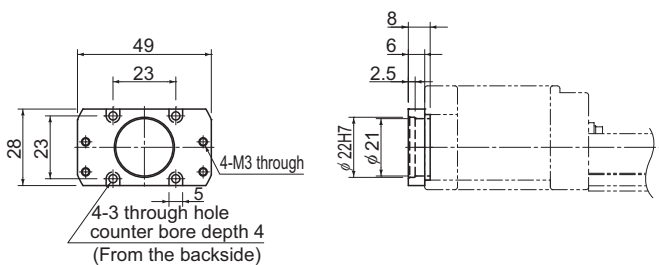

SKR26

AN

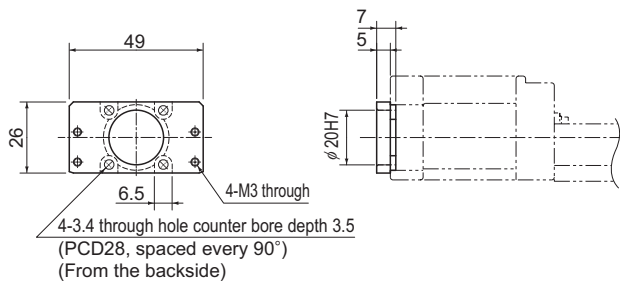

Motor Wrap Housing A

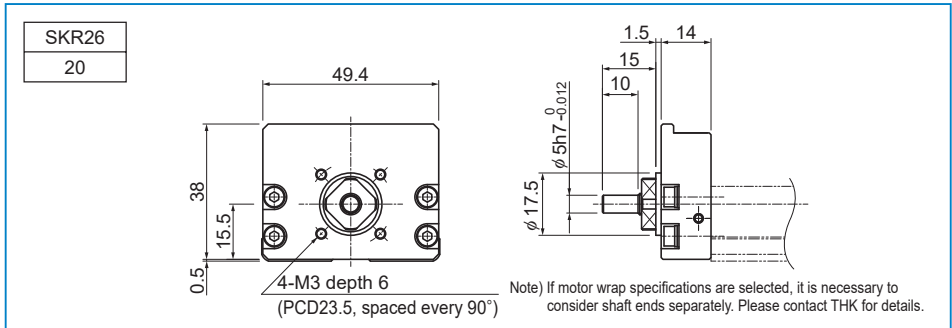

SKR**	··· Actuator model number
W□	··· □: Intermediate flange

Motor Wrap Specifications (Intermediate Flange)

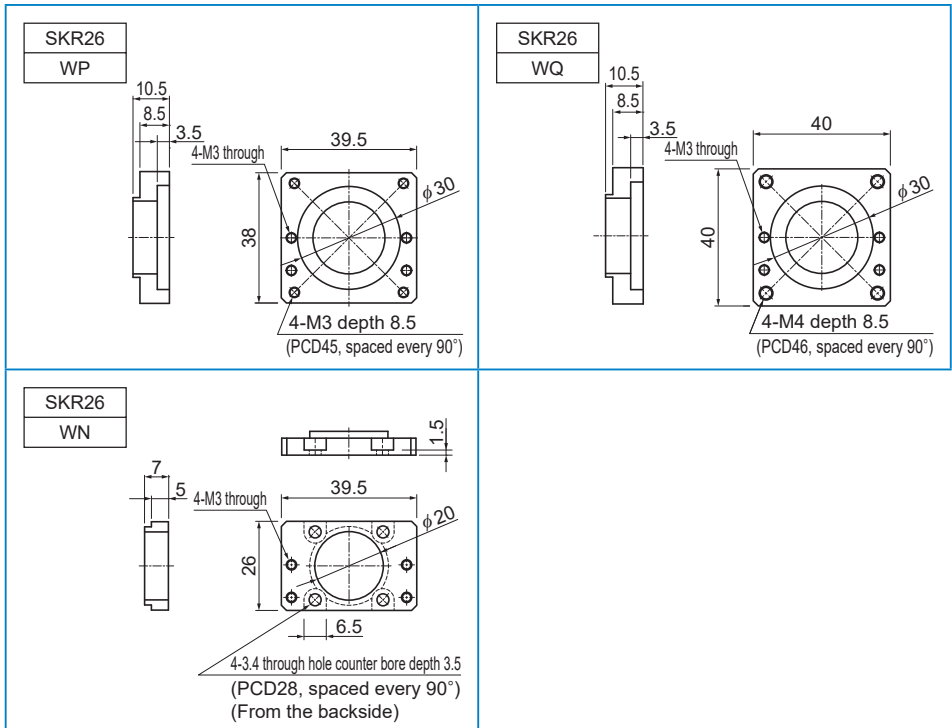

● For Model SKR33

SKR**	···· Actuator model number
●◇	····●: Housing A
	◇: Intermediate flange

■ Housing A

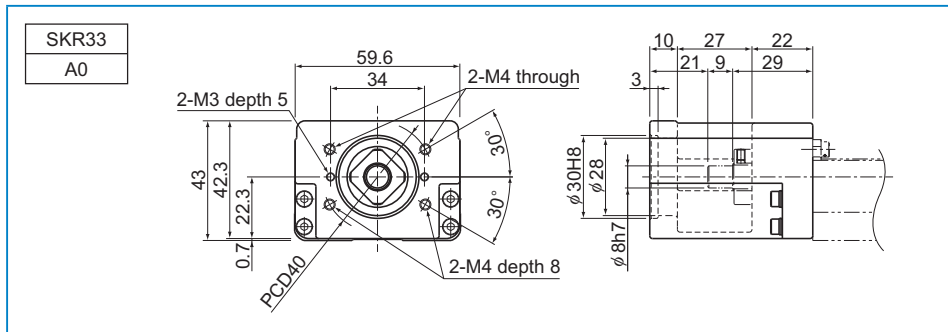

■ Intermediate Flange

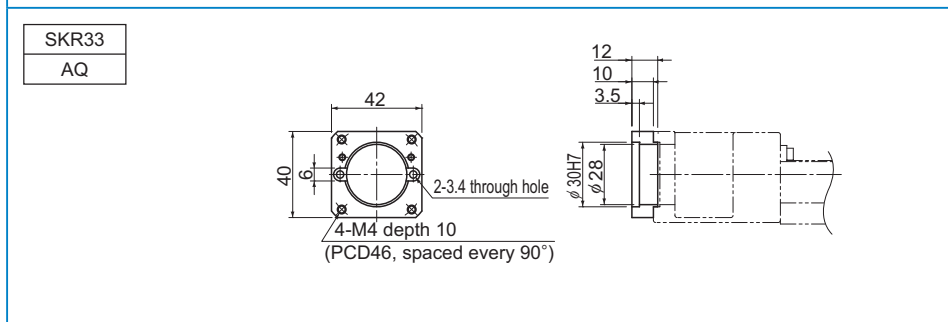
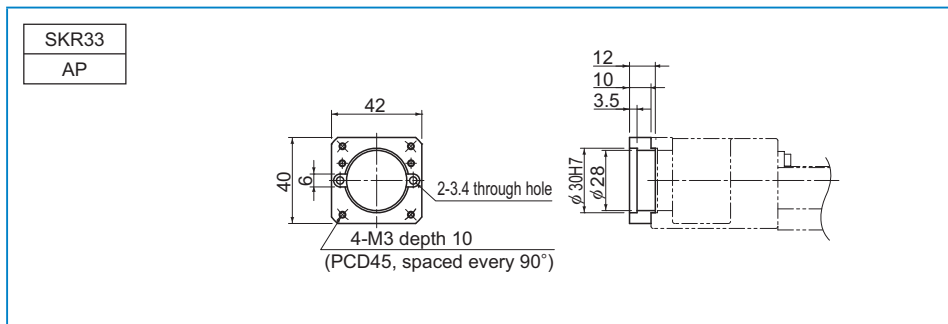

SKR33

AR

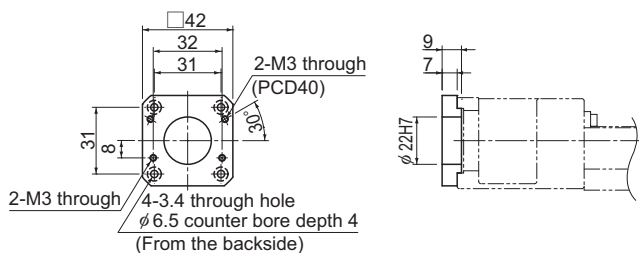

SKR33

AT

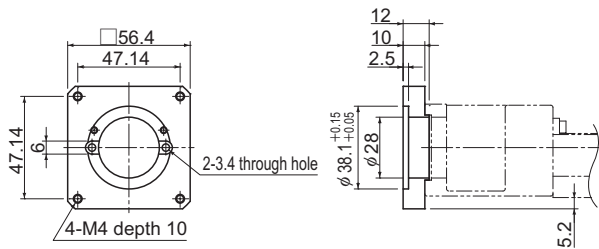

SKR33

AU

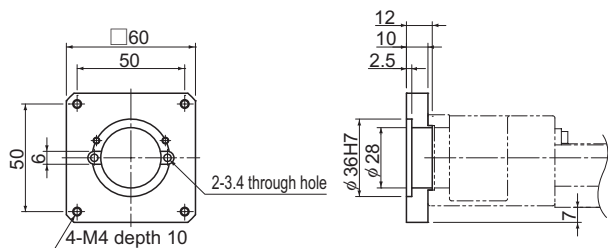

Motor Wrap Housing A

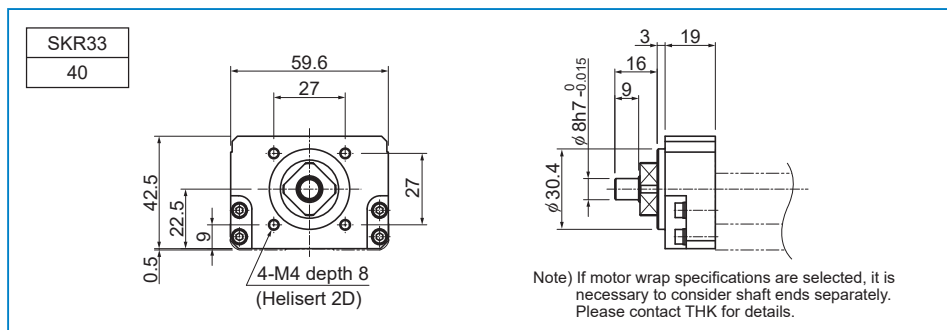

SKR**	...Actuator model number
W□	...□: Intermediate flange

Motor Wrap Specifications (Intermediate Flange)

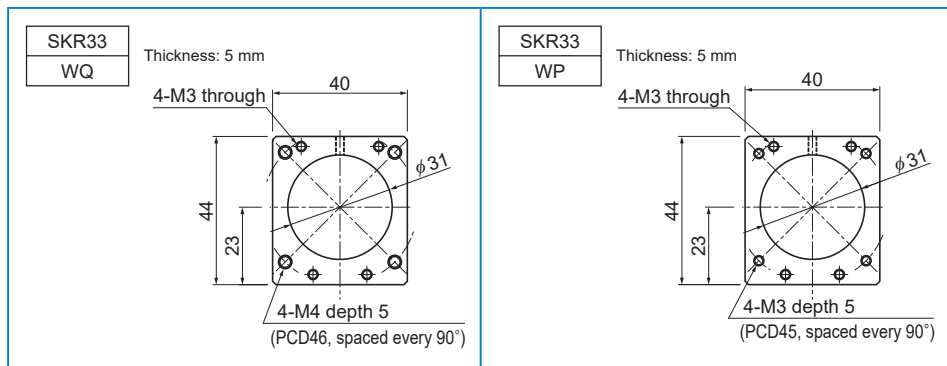

● For Model SKR46

SKR**	··· Actuator model number
●◇	··· ●: Housing A ◇: Intermediate flange

■ Housing A

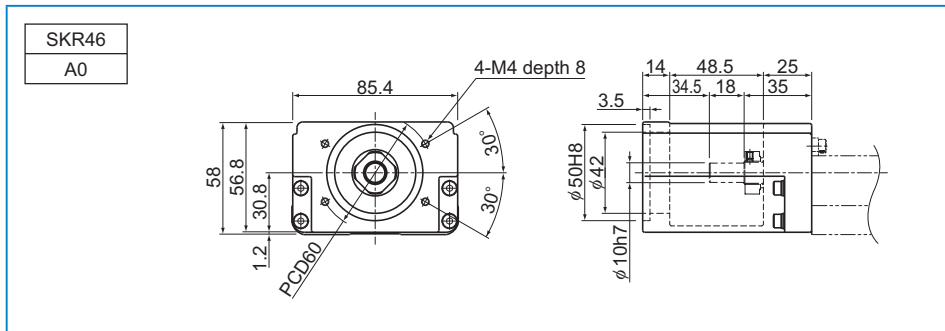

■ Intermediate Flange

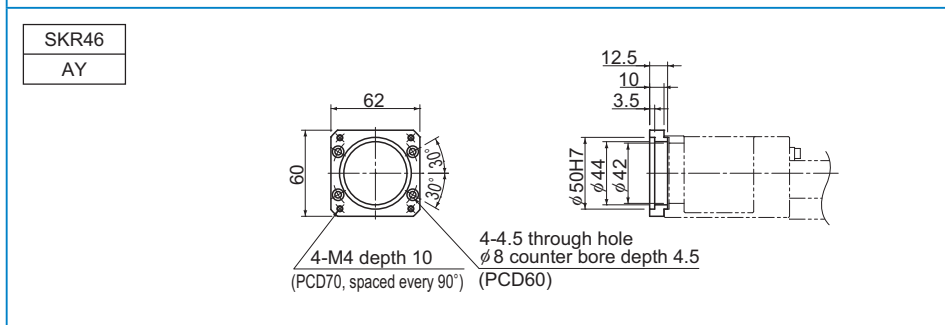
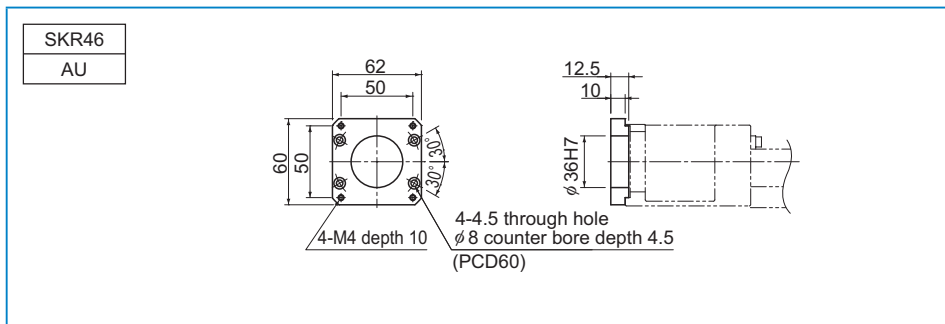

SKR46

AV

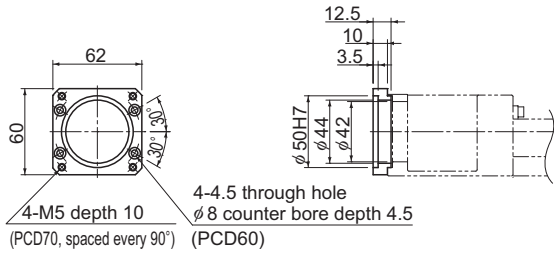

Motor Wrap Housing A

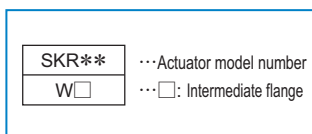
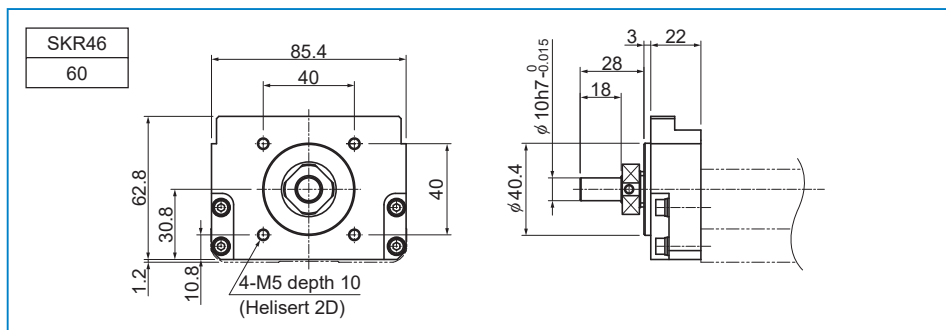

Motor Wrap Specifications (Intermediate Flange)

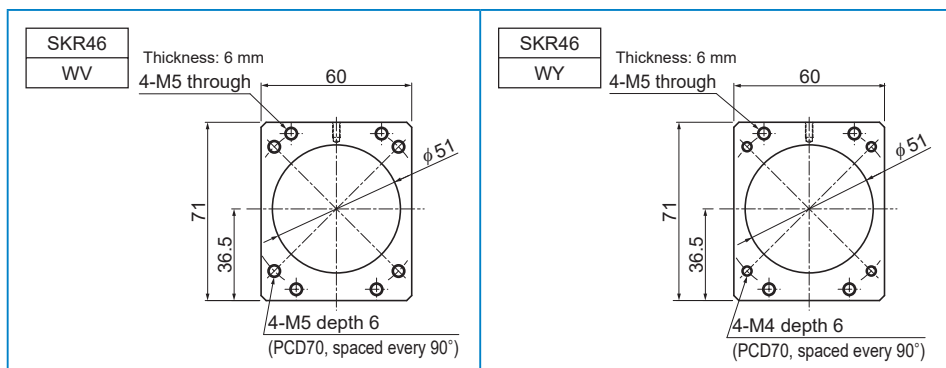

● For Model SKR55

SKR**	···· Actuator model number
●◇	····●: Housing A
	◇: Intermediate flange

■ Housing A

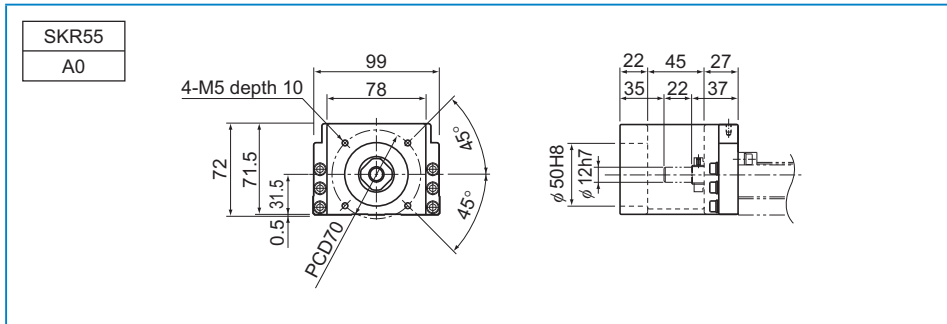

■ Intermediate Flange

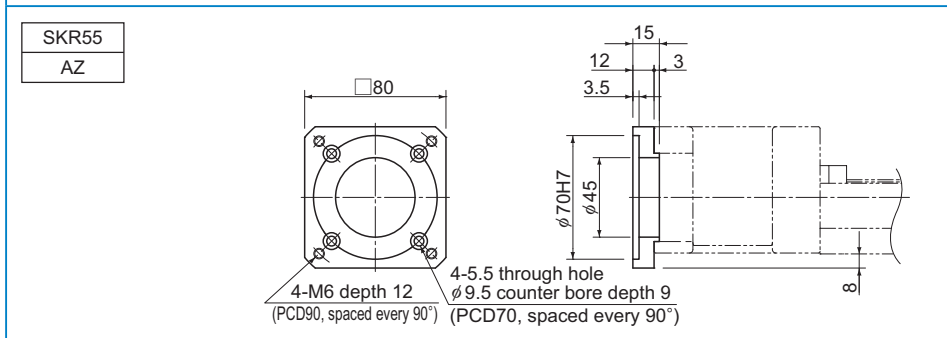
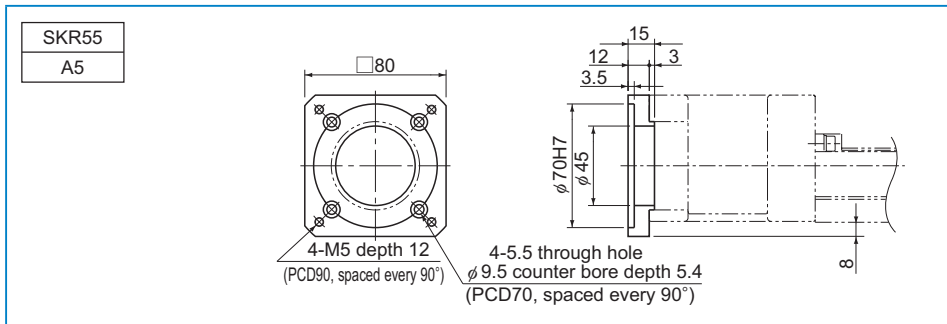

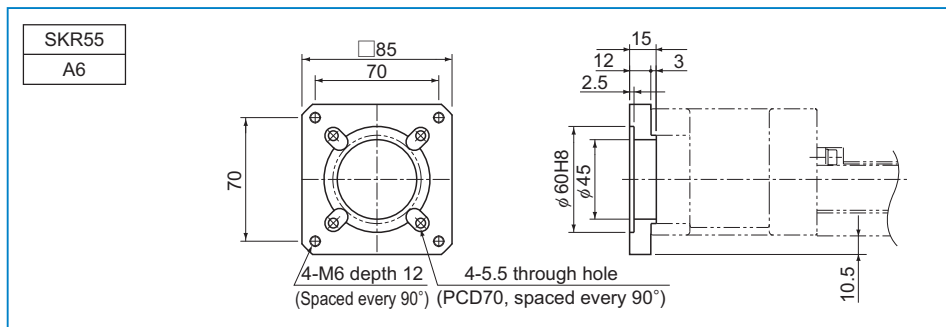

Motor Wrap Housing A

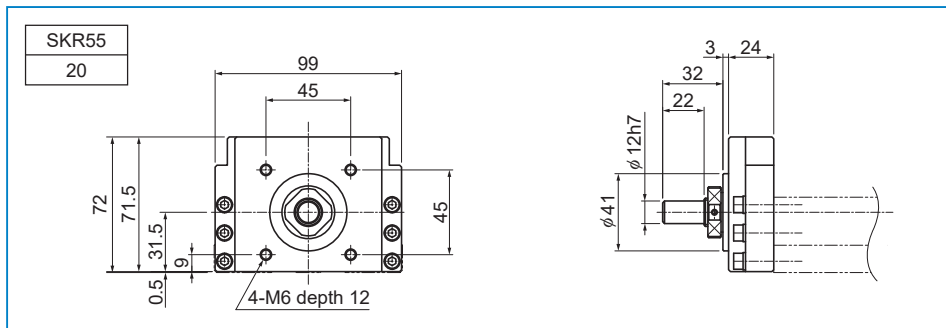

SKR**
W□

...Actuator model number
...□: Intermediate flange

Motor Wrap Specifications (Intermediate Flange)

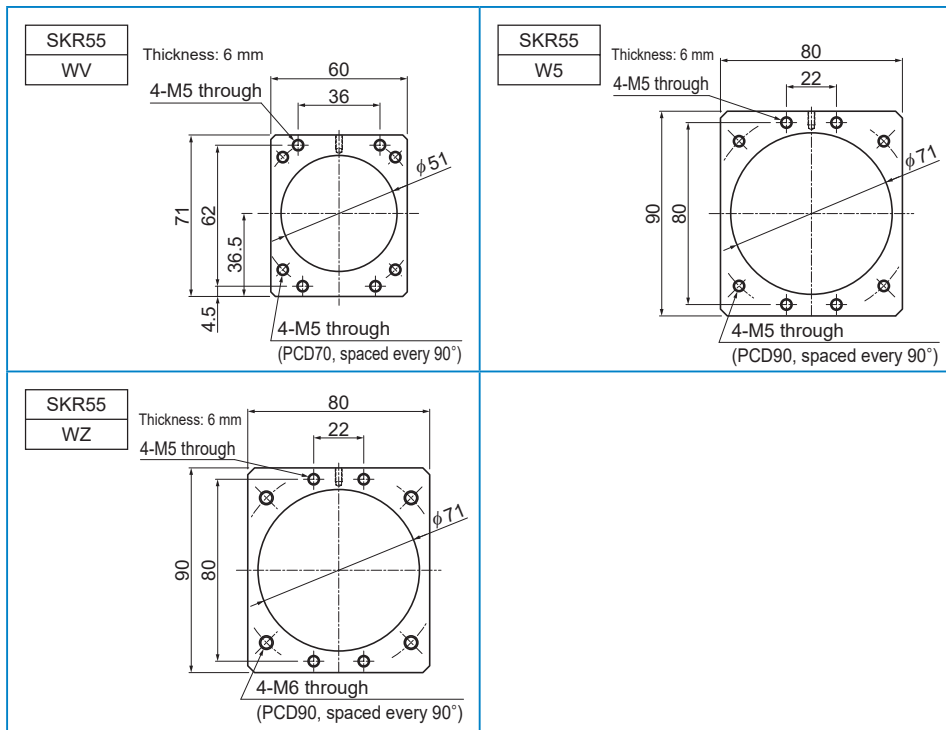

● For Model SKR65

SKR**	··· Actuator model number
●◇	···●: Housing A ◇: Intermediate flange

■ Housing A

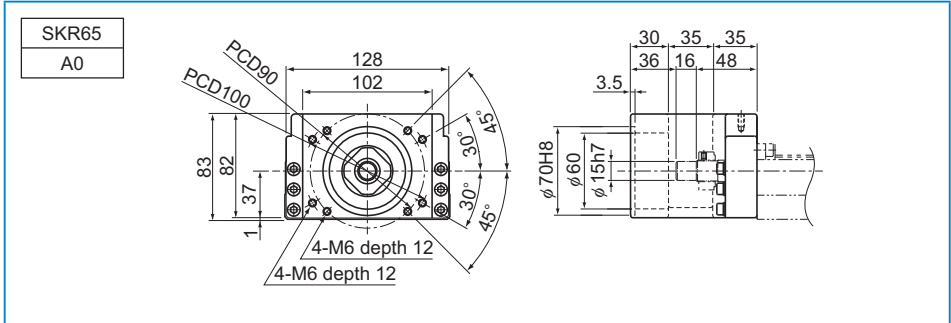

■ Intermediate Flange

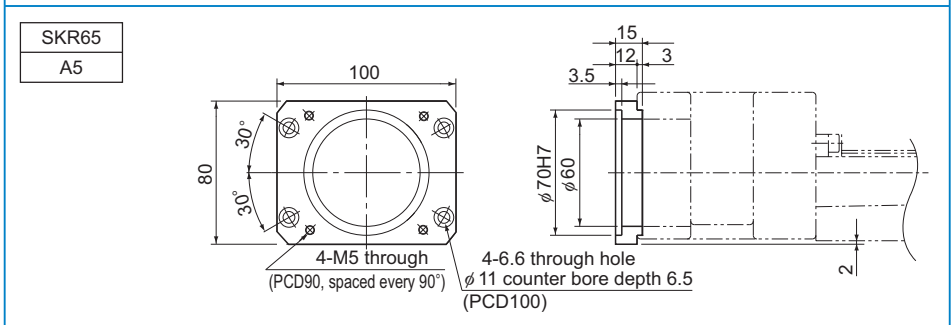
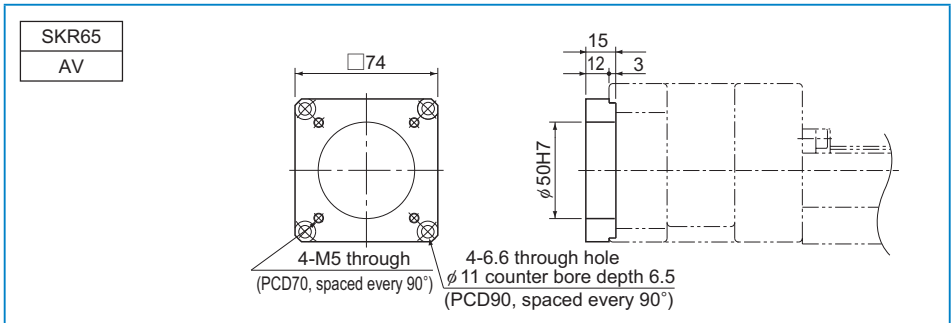

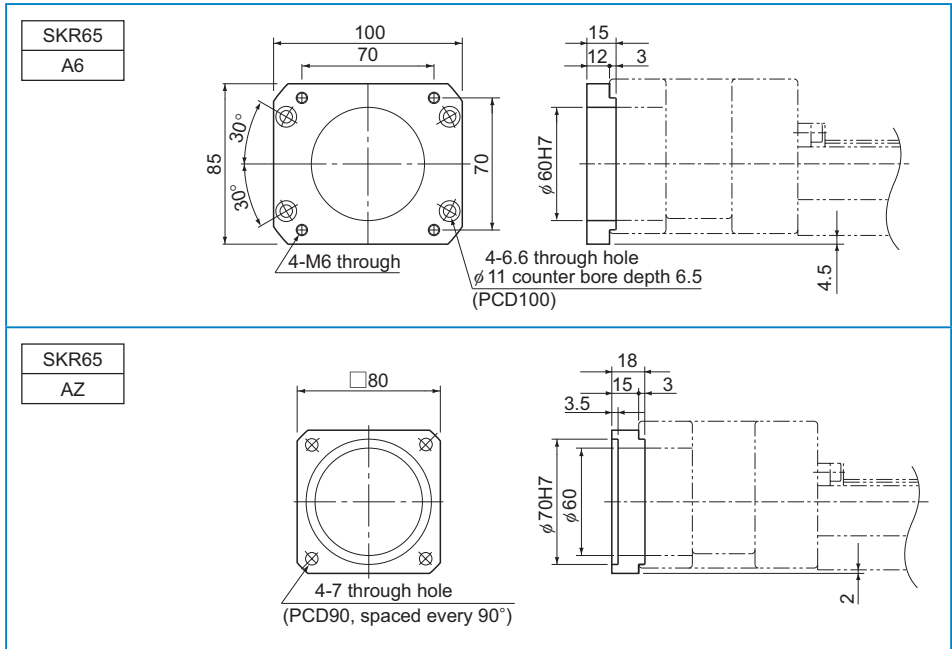

Motor Wrap Housing A

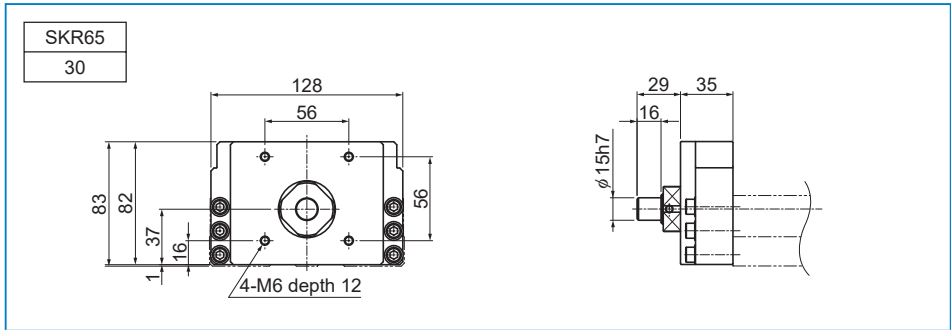

SKR**	··· Actuator model number
W□	··· □: Intermediate flange

Motor Wrap Specifications (Intermediate Flange)

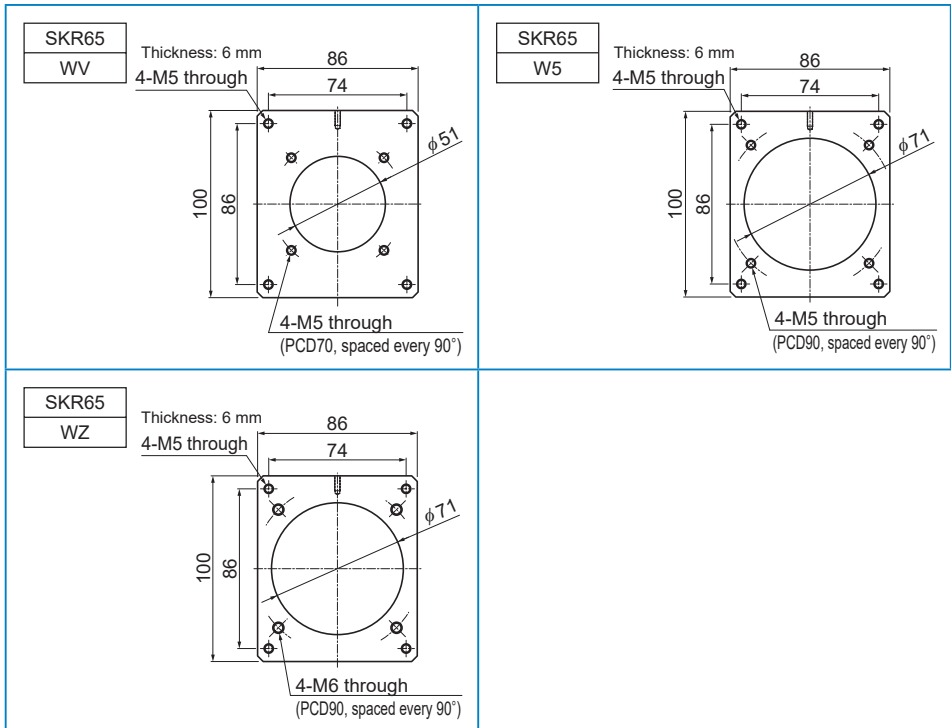

KR

LM Guide Actuator Model KR

LM Guide + Ball Screw = Integral-structure Actuator

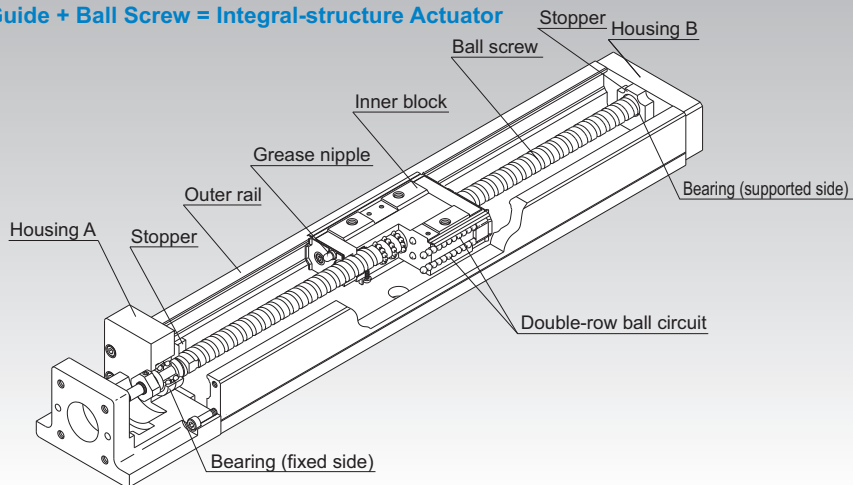

Fig.1 Structure of LM Guide Actuator Model KR

Structure and Features

Because of its integral-structure inner block consisting of a highly rigid outer rail with a U-shaped cross section, LM Guide units on both side faces and a Ball Screw unit in the center, LM Guide Actuator model KR achieves a highly rigid and highly accurate actuator in a minimal space.

In addition, since the housings A and B also serve as support units and the inner block as a table, this model allows significant reduction of man-hours required for design and assembly, thus contributing to total cost cutting.

[4-way Equal Load]

Each row of balls is arranged at a contact angle of 45° so that the rated load on the inner block is uniform under loads applied to the inner block in the four directions (radial, reverse radial and lateral directions). As a result, model KR can be used in any mounting orientation.

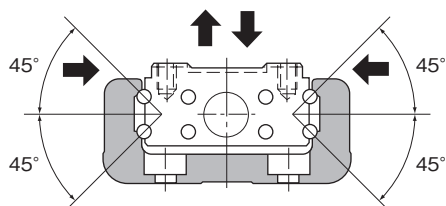

Fig.2 Load Capacity and Contact Angle of Model KR

[High Rigidity]

Use of an outer rail with a U-shaped cross section increases the rigidity against a moment and torsion.

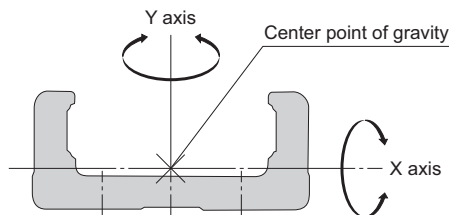

Fig.3 Cross Section of the Outer Rail

Table1 Cross-sectional Characteristics of the Outer rail Rail

Model No.	$I_x[\text{mm}^4]$	$I_y[\text{mm}^4]$	Mass[kg/m]
KR15	9.08×10^2	1.42×10^4	1.04
KR20	6.1×10^3	6.2×10^4	2.6
KR26	1.7×10^4	1.5×10^5	3.9
KR30H	2.7×10^4	2.8×10^5	5.0
KR33	6.2×10^4	3.8×10^5	6.6
KR45H	8.4×10^4	8.9×10^5	9.0
KR46	2.4×10^5	1.5×10^6	12.6
KR55	2.2×10^5	2.3×10^6	15.0
KR65	4.6×10^5	5.9×10^6	23.1

I_x =geometrical moment of inertia around X axis

I_y =geometrical moment of inertia around Y axis

[High Accuracy]

Since the linear guide consists of four rows of circular-arc grooves that enable balls to smoothly move with two points of contact even under a preload, a highly rigid guide with no clearance is achieved. Additionally, variation in frictional resistance caused by load fluctuation is minimized, allowing highly accurate feeding. The system contributes significantly to increasing precision and quality by providing precision-grade positioning performance to all kinds of machines.

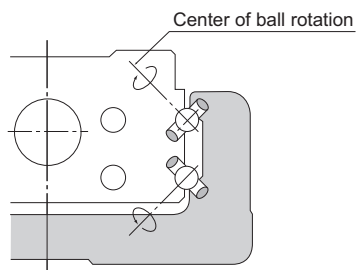

Fig.4 Contact Structure of Model KR

[Space Saving]

Use of a inner block integrating LM Guide units on both ends and a Ball Screw unit in the center makes model KR a highly rigid and highly accurate actuator in a minimal space.

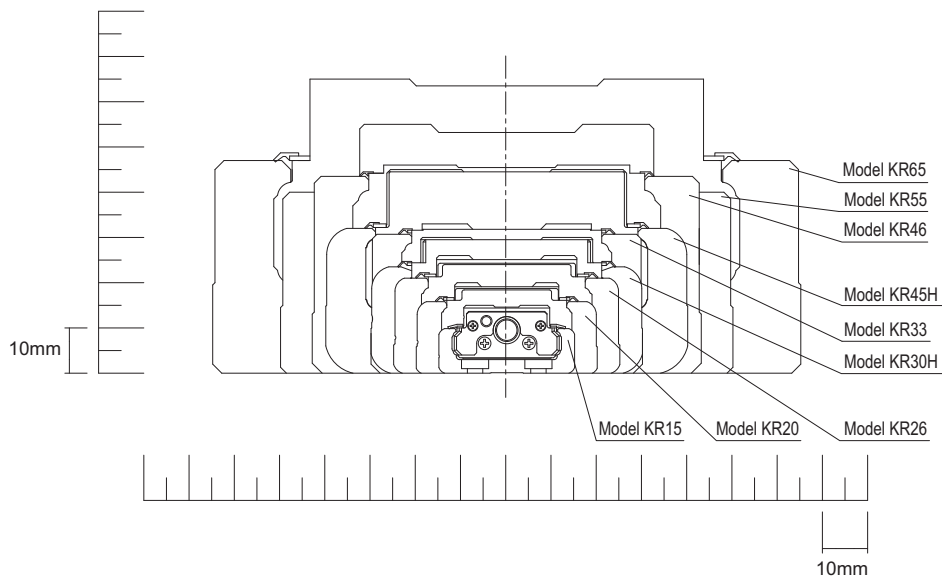

Fig.5 Cross Sectional Drawing

[Seal]

Model KR is equipped with end seals and side seals for dust prevention as standard.

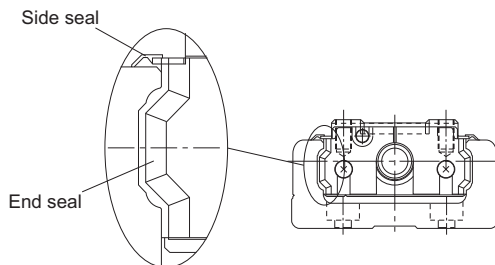

Table2 shows the rolling resistance and seal resistance per inner block (guide section).

Table2 Maximum Resistance Value Unit: N

Model No.	Rolling resistance value	Seal resistance value	Total
KR15	0.2	0.7	0.9
KR20	0.5	0.7	1.2
KR26	0.6	0.8	1.4
KR30H	1.5	2.0	3.5
KR33	1.5	1.9	3.4
KR45H	2.5	2.6	5.1
KR46	2.5	2.5	5
KR55	5.0	3.8	8.8
KR65	6.0	4.1	10.1

Note) The rolling resistance represents the value when a lubricant is not used.

Types and Configurations

[Types]

Model KR-A (with a Single Long Type Block)

Representative model of KR.

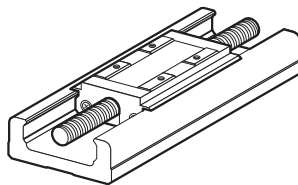

Model KR-A

Model KR-B (with Two Long Type Blocks)

Equipped with two units of the inner block of model KR-A, this model achieves higher rigidity and higher load carrying capacity.

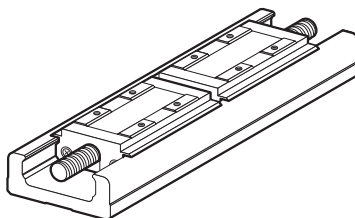

Model KR-B

Model KR-C (with a Single Short Type Block)

This model has a shorter overall length of the inner block and a longer stroke than model KR-A.

(Supported models: model KR30H, 33, 45H, 46)

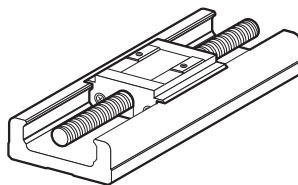

Model KR-C

Model KR-D (with Two Short Type Blocks)

Equipped with two units of the inner block of model KR-C, this design allows a span between blocks that suits the equipment, thus achieving high rigidity.

(Supported models: model KR30H, 33, 45H, 46)

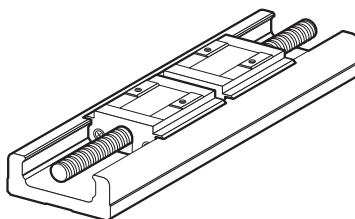

Model KR-D

[Configurations]

Direct motor coupling (without cover)

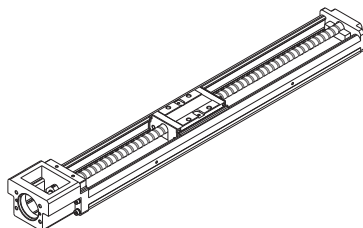

Direct motor coupling (with cover)

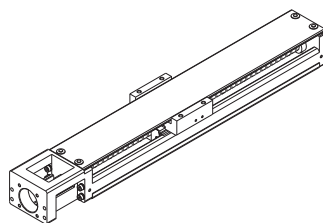

Motor wrap (without cover)

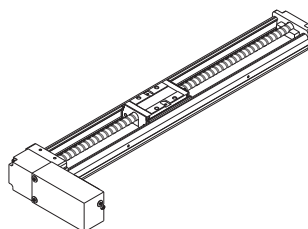

Motor wrap (with cover)

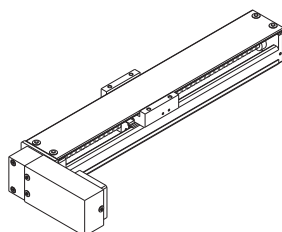

Load Ratings in All Directions and Static Permissible Moment

[Load Rating]

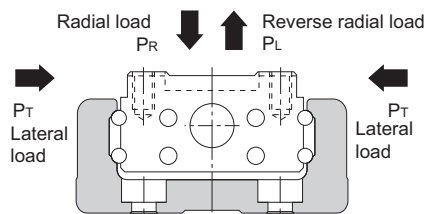

● LM Guide Unit

Model KR is capable of receiving loads in four directions (radial, reverse radial and lateral directions). Its basic load ratings are equal in all four directions (radial, reverse radial and lateral directions), and their values are indicated in Table3 on **A2-120** and **A2-121**.

● Ball Screw Unit

Since the inner block is incorporated with a ball screw nut, model KR is capable of receiving an axial load. The basic load rating value is indicated in Table3 on **A2-120** and **A2-121**.

● Bearing Unit (Fixed Side)

Since housing A contains an angular bearing, model KR is capable of receiving an axial load. The basic load rating value is indicated in Table3 on **A2-120** and **A2-121**.

[Equivalent Load (LM Guide Unit)]

The equivalent load when the LM Guide unit of model KR simultaneously receives loads in all directions is obtained from the following equation.

$$P_E = P_R (P_L) + P_T$$

P_E : Equivalent load (N)

: Radial direction

: Reverse radial direction

: Lateral direction

P_R : Radial load (N)

P_L : Reverse radial load (N)

P_T : Lateral load (N)

Table3 Load Rating of Model KR

Model No.			KR15		KR20		KR26		
			KR1501	KR1502	KR2001	KR2006	KR2602	KR2606	
LM guide unit	Basic dynamic load rating C (N)	Long type block	1930		3590		7240		
		Short type block	—		—		—		
	Basic static load rating C ₀ (N)	Long type block	3450		6300		12150		
		Short type block	—		—		—		
	Radial clearance (mm)	Normal grade, high accuracy grade	-0.001 to +0.002		-0.003 to +0.002		-0.004 to +0.002		
		Precision grade	-0.005 to -0.002		-0.007 to -0.003		-0.01 to -0.004		
Ball screw unit	Basic dynamic load rating C _a (N)	Normal grade, high accuracy grade	340	230	660	860	2350	1950	
		Precision grade	340	230	660	1060	2350	2390	
	Basic static load rating C _{0a} (N)	Normal grade, high accuracy grade	660	410	1170	1450	4020	3510	
		Precision grade	660	410	1170	1600	4020	3900	
	Screw shaft diameter (mm)		5		6		8		
	Lead (mm)		1	2	1	6	2	6	
	Thread minor diameter (mm)		4.5		5.3	5.0	6.6	6.7	
	Ball center-to-center diameter (mm)		5.15		6.15	6.3	8.3	8.4	
Bearing unit (Fixed side)	Axial direction	Basic dynamic load rating C _a (N)	590		1000		1380		
		Static permissible load P _{0a} (N)	290		1240		1760		

Note1) The load ratings in the LM Guide unit each indicate the load rating per inner block.

Note2) The Ball Screw of precision grade (grade P) for models KR30H, KR33, KR45H10 and KR4610 is incorporated with spacer balls in the proportion of one to one.

Note3) The Ball Screw of precision grade (grade P) for models KR45H20, KR4620, KR55 and KR65 is incorporated with spacer balls in the proportion of two to one.

	KR30H		KR33		KR45H		KR46		KR55	KR65
	KR30H06	KR30H10	KR3306	KR3310	KR45H10	KR45H20	KR4610	KR4620		
	11600		11600		23300		27400		38100	50900
	4900		4900		11900		14000		—	—
	20200		20200		39200		45500		61900	80900
	10000		10000		19600		22700		—	—
	-0.004 to +0.002		-0.004 to +0.002		-0.006 to +0.003		-0.006 to +0.003		-0.007 to +0.004	-0.008 to +0.004
	-0.012 to -0.004		-0.012 to -0.004		-0.016 to -0.006		-0.016 to -0.006		-0.019 to -0.007	-0.022 to -0.008
	2840	1760	2840	1760	3140	3040	3140	3040	3620	5680
	2250	1370	2250	1370	2940	3430	2940	3430	3980	5950
	4900	2840	4900	2840	6760	7150	6760	7150	9290	14500
	2740	1570	2740	1570	3720	5290	3720	5290	6850	10700
	10		10		15		15		20	25
	6	10	6	10	10	20	10	20	20	25
	7.8		7.8		12.5		12.5		17.5	22
	10.5		10.5		15.75		15.75		20.75	26
	1790		1790		6660		6660		7600	13700
	2590		2590		3240		3240		3990	5830

[Static Permissible Moment (LM Guide Unit)]

The Inner block is capable of receiving moment loads in all three (3) directions.

Table 4 on **A2-123** shows static permissible moments in the M_A , M_B and M_C directions.

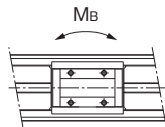
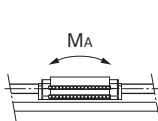
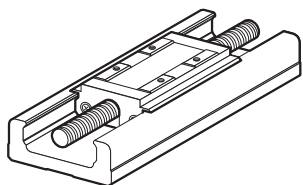

With a single long type block (Model KR-A)

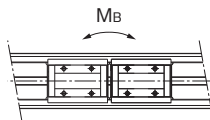
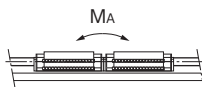
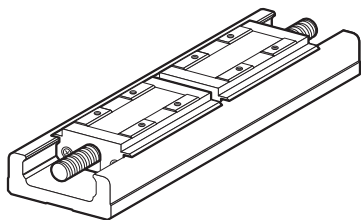

With double long type blocks (Model KR-B)

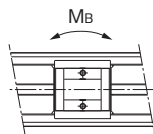
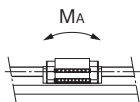
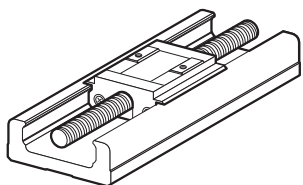

With a single short type block (Model KR-C)

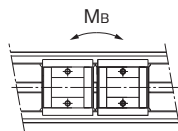
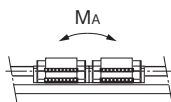
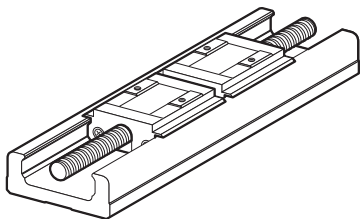

With double short type blocks (Model KR-D)

Table4 Static Permissible Moments of Model KR

Unit: N·m

Model No.	Static permissible moment		
	M _A	M _B	M _C
KR15-A	12.1 (5)	12.1 (5)	38 (5)
KR15-B	70.3 (16)	70.3 (22)	76 (18)
KR20-A	31 (9)	31 (8)	83 (13)
KR20-B	176 (39)	176 (32)	165 (27)
KR26-A	84 (31)	84 (22)	208 (30)
KR26-B	480 (154)	480 (78)	416 (60)
KR30H-A	166 (32)	166 (40)	428 (46)
KR30H-B	908 (256)	908 (155)	857 (103)
KR30H-C	44 (10)	44 (14)	214 (20)
KR30H-D	319 (84)	319 (55)	427 (51)
KR33-A	166 (53)	166 (40)	428 (53)
KR33-B	908 (271)	908 (158)	857 (107)
KR33-C	44 (7)	44 (14)	214 (26)
KR33-D	319 (90)	319 (56)	427 (53)
KR45H-A	486 (34)	486 (95)	925 (31)
KR45H-B	2732 (159)	2732 (355)	1850 (63)
KR45H-C	130 (16)	130 (32)	463 (15)
KR45H-D	994 (52)	994 (124)	925 (31)
KR46-A	547 (34)	547 (98)	1400 (34)
KR46-B	2940 (165)	2940 (364)	2800 (69)
KR46-C	149 (18)	149 (34)	700 (17)
KR46-D	1010 (54)	1010 (129)	1400 (34)
KR55-A	870 (169)	870 (212)	2280 (169)
KR55-B	4890 (863)	4890 (831)	4570 (338)
KR65-A	1300 (326)	1300 (448)	3920 (326)
KR65-B	7230 (1349)	7230 (1512)	7840 (653)

Note1) Symbols A, B, C or D in the end of each model number indicates the inner block size and the number of inner blocks used.

A: With a single long type block

B: With double long type blocks

C: With a single short type block

D: With double short type blocks

Note2) The values for models KR-B/D indicate the values when double inner blocks are used in close contact with each other.

Note3) Static permissible moment is the maximum moment that can be permitted while the product is stationary.

Note4) Values in parentheses are with a cover or bellows.

Maximum Speeds with Different Strokes

Table5 Maximum speed

Model No.	Ball Screw lead (mm)	Stroke* (mm)		Outer rail length (mm)	Maximum speed (mm/s)					
					Precision grade	High accuracy grade	Normal grade	Precision grade	High accuracy grade	Normal grade
		Long type block	Short type block		Long type block			Short type block		
KR15	1	25	—	75	75	75	—	—	—	
		50	—	100	75	75	—	—	—	
		75	—	125	75	75	—	—	—	
		100	—	150	75	75	—	—	—	
		125	—	175	75	75	—	—	—	
	2	150	—	200	75	75	—	—	—	
		25	—	75	150	150	—	—	—	
		50	—	100	150	150	—	—	—	
		75	—	125	150	150	—	—	—	
		100	—	150	150	150	—	—	—	
KR20	1	125	—	175	150	150	—	—	—	
		150	—	200	150	150	—	—	—	
		30	—	100	100	100	—	—	—	
	6	80	—	150	100	100	—	—	—	
		130	—	200	100	100	—	—	—	
KR26	2	30	—	100	600	600	—	—	—	
		80	—	150	600	600	—	—	—	
		130	—	200	600	600	—	—	—	
	6	60	—	150	200	200	—	—	—	
		110	—	200	200	200	—	—	—	
		160	—	250	200	200	—	—	—	
		210	—	300	200	200	—	—	—	
KR30H	6	60	—	150	600	590	—	—	—	
		110	—	200	600	590	—	—	—	
		160	—	250	600	590	—	—	—	
		210	—	300	600	590	—	—	—	
		50	70	150	600	470	600	470		
	10	100	120	200	600	470	600	470		
		200	220	300	600	470	600	470		
		300	320	400	600	470	600	470		
		400	420	500	590	470	530	470		
		500	520	600	390	390	360	360		
KR33	6	50	70	150	1000	790	1000	790		
		100	120	200	1000	790	1000	790		
		200	220	300	1000	790	1000	790		
		300	320	400	1000	790	1000	790		
		400	420	500	980	790	880	790		
		500	520	600	650	650	600	600		
	10	50	75	150	600	470	600	470		
		100	125	200	600	470	600	470		
		200	225	300	600	470	600	470		
		300	325	400	600	470	600	470		
		400	425	500	590	470	530	470		
		500	525	600	390	390	360	360		
		600	625	700	280	280	260	260		
KR33	10	50	75	150	1000	790	1000	790		
		100	125	200	1000	790	1000	790		
		200	225	300	1000	790	1000	790		
		300	325	400	1000	790	1000	790		
		400	425	500	980	790	880	790		
		500	525	600	650	650	600	600		
		600	625	700	470	470	430	430		

Model No.	Ball Screw lead (mm)	Stroke* (mm)		Outer rail length (mm)	Maximum speed (mm/s)					
					Precision grade	High accuracy grade	Normal grade	Precision grade	High accuracy grade	Normal grade
		Long type block	Short type block		Long type block			Short type block		
KR45H	10	200	230	340	740	520	740	520	740	520
		300	330	440	740	520	740	520	740	520
		400	430	540	740	520	740	520	740	520
		500	530	640	740	520	740	520	740	520
		600	630	740	730	520	640	520	740	520
		700	730	840	550	520	490	490	740	520
		800	830	940	430	430	380	380	740	520
	20	200	230	340	1480	1050	1480	1050	1480	1050
		300	330	440	1480	1050	1480	1050	1480	1050
		400	430	540	1480	1050	1480	1050	1480	1050
		500	530	640	1480	1050	1480	1050	1480	1050
		600	630	740	1430	1050	1280	1050	1480	1050
		700	730	840	1080	1050	980	980	1480	1050
		800	830	940	840	840	770	770	1480	1050
KR46	10	190	220	340	740	520	740	520	740	520
		290	320	440	740	520	740	520	740	520
		390	420	540	740	520	740	520	740	520
		490	520	640	740	520	740	520	740	520
		590	620	740	730	520	650	520	740	520
		690	720	840	550	520	490	490	740	520
		790	820	940	430	430	390	390	740	520
	20	190	220	340	1480	1050	1480	1050	1480	1050
		290	320	440	1480	1050	1480	1050	1480	1050
		390	420	540	1480	1050	1480	1050	1480	1050
		490	520	640	1480	1050	1480	1050	1480	1050
		590	620	740	1440	1050	1300	1050	1480	1050
		690	720	840	1090	1050	990	990	1480	1050
		790	820	940	850	850	780	780	1480	1050
KR55	20	800	—	980	1120	800	—	—	—	—
		900	—	1080	900	800	—	—	—	—
		1000	—	1180	740	740	—	—	—	—
		1100	—	1280	—	620	—	—	—	—
		1200	—	1380	—	530	—	—	—	—
KR65	25	790	—	980	1120	800	—	—	—	—
		990	—	1180	1120	800	—	—	—	—
		1190	—	1380	840	800	—	—	—	—
		1490	—	1680	—	550	—	—	—	—

*Indicates a stroke when one inner block is incorporated.

Note1) The maximum speed is restricted by the permissible rotation speed of the ball screw, the permissible speed of the guide or 6,000 min⁻¹ of motor speed.

Note2) If you are considering using this product at the maximum travel speed of Table5 or faster, contact THK.

Lubrication

Table6 shows standard greases used in model KR and grease nipple types.

Table6 Types of standard grease and grease nipples used

Model No.	Standard grease	Grease nipple used
KR15	THK AFF Grease	—
KR20	THK AFA Grease	PB107
KR26	THK AFA Grease	PB107
KR30H	THK AFB-LF Grease	PB107
KR33	THK AFB-LF Grease	PB107
KR45H	THK AFB-LF Grease	A-M6F
KR46	THK AFB-LF Grease	A-M6F
KR55	THK AFB-LF Grease	A-M6F
KR65	THK AFB-LF Grease	A-M6F

Static Safety Factor

LM Guide Actuator Model KR consists of an LM Guide, a Ball Screw and a support bearing. The static safety factor and the service life of each component can be obtained from the basic load rating indicated in "Rated load of model KR" (see Table3 on **A2-120**).

[Calculating the Static Safety Factor]

● LM Guide Unit

To calculate a load applied to the LM Guide of model KR, the average load required for calculating the service life and the maximum load needed for calculating the static safety factor must be obtained first. In particular, if the system starts and stops frequently, or if a large moment caused by an overhung load is applied to the system, it may receive an unexpectedly large load.

When selecting a model number, make sure that the desired model is capable of receiving the required maximum load (whether stationary or in motion).

$$f_s = \frac{C_0}{P_{\max}}$$

f_s : Static safety factor

C_0 : Basic static load rating (N)

P_{\max} : Maximum applied load (N)

*The basic static load rating is a static load with a constant direction and magnitude whereby the sum of the permanent deformation of the rolling element and that of the raceway on the contact area under the maximum stress is 0.0001 times the rolling element diameter.

● Ball Screw Unit/Bearing Unit(Fixed Side)

If an unexpected external force is applied in the axial direction as a result of an inertia caused by an impact or start and stop while model KR is stationary or operating, it is necessary to take into account the static safety factor.

$$f_s = \frac{C_{0a}}{F_{\max}}$$

f_s : Static safety factor

C_{0a} : Basic static load rating (N)

F_{\max} : Maximum applied load (N)

[Standard Values for the Static Safety Factor (f_s)]

Machine type	Load conditions	Minimum Static Safety Factor (f_s)
General industrial machinery	Without vibration or impact	1.0 to 3.5
	With vibration or impact	2.0 to 5.0

*The standard value of the static safety factor may vary depending on the load conditions as well as environment, lubrication status, mounting accuracy, and/or rigidity.

Service Life

[LM Guide Unit]

● Nominal Life

■ Calculating the Nominal Life

The nominal life (L_{10}) of an LM Guide with balls is obtained from the following formula using the basic dynamic load rating (C), which is based on a reference distance of 50 km, and the calculated load acting on the LM Guide (P_c).

- LM Guide with balls (Using a basic dynamic load rating based on a nominal life of 50 km)

$$L_{10} = \left(\frac{C}{P_c} \right)^3 \times 50 \quad \dots\dots\dots (1)$$

L_{10}	:	Nominal life	(km)
C	:	Basic dynamic load rating	(N)
P_c	:	Calculated load	(N)

*This nominal life formula may not apply if the length of the stroke is less than or equal to twice the length of the LM block.

When comparing the nominal life (L_{10}), you must take into account whether the basic dynamic load rating was defined based on 50 km or 100 km. Convert the basic dynamic load rating based on ISO 14728-1 as necessary.

ISO-regulated basic dynamic load rating conversion formula:

- LM Guide with balls

$$C_{100} = \frac{C_{50}}{1.26}$$

C_{50}	:	Basic dynamic load rating based on a nominal life of 50 km
C_{100}	:	Basic dynamic load rating based on a nominal life of 100 km

■ Calculating the Modified Nominal Life

During use, an LM Guide may be subjected to vibrations and shocks as well as fluctuating loads, which are difficult to detect. In addition, having LM blocks arranged directly behind one another will have a decisive impact on the service life. Taking these factors into account, the modified nominal life (L_{10m}) can be calculated according to the following formula (2).

● Modified factor α

$$\alpha = \frac{f_c}{f_w}$$

α	:	Modified factor
f_c	:	Contact factor (see Table7 on A2-131)
f_w	:	Load factor (see Table8 on A2-131)

● Modified nominal life L_{10m}

- LM Guide with balls

$$L_{10m} = \left(\alpha \times \frac{C}{P_c} \right)^3 \times 50 \quad \dots\dots\dots (2)$$

L_{10m}	:	Modified nominal life	(km)
C	:	Basic dynamic load rating	(N)
P_c	:	Calculated load	(N)

- If a moment is applied to model KR-A/C or model KR-B/D using two inner blocks in close contact with each other, calculate the equivalent load by multiplying the applied moment by the equivalent factor indicated in Table9 on **A2-131**.

$$P_m = K \cdot M$$

- P_m : Equivalent load (per inner block) (N)
 K : Equivalent moment factor (see Table9 on **A2-131**)
 M : Applied moment (N·mm)
 (If planning to use the product with a wide inner block span, contact THK.)

- If moment M_c is applied to model KR-B/D

$$P_m = \frac{K_c \cdot M_c}{2}$$

- If a radial load (P) and a moment are simultaneously applied to model KR

$$P_E = P_m + P$$

- P_E : Total equivalent radial load (N)
 Perform a nominal life calculation using the above data.

● Service Life Time

When the nominal life (L_{10}) has been obtained, the service life time is obtained using the following equation (if the stroke length and the number of reciprocations per minute are constant).

$$L_h = \frac{L_{10} \times 10^6}{2 \cdot \ell_s \cdot n_1 \times 60}$$

- L_h : Service life time (h)
 ℓ_s : Stroke length (mm)
 n_1 : Number of reciprocations per minute (min^{-1})

[Ball Screw Unit/Bearing Unit(Fixed Side)]

● Nominal Life

■ Calculating the Nominal Life

The nominal life (L_{10}) of an LM system is obtained from the following formula using the basic dynamic load rating (C) and the load acting on the ball screw in the axial direction (F_a).

$$L_{10} = \left(\frac{C_a}{F_a} \right)^3 \times 10^6 \dots\dots\dots(1)$$

L_{10}	: Nominal life	(rev.)
C_a	: Basic dynamic load rating	(N)
F_a	: Axial load	(N)

■ Calculating the Modified Nominal Life

During use, a ball screw may be subjected to vibrations and shocks as well as fluctuating loads, which are difficult to detect. Taking these factors into account, the modified nominal life (L_{10m}) can be calculated according to the following formula (2).

- Modified factor α

$$\alpha = \frac{1}{f_w}$$

α	: Modified factor	
f_w	: Load factor	(see Table8 on A2-131)

- Modified nominal life L_{10m}

$$L_{10m} = \left(\alpha \times \frac{C_a}{F_a} \right)^3 \times 10^6 \dots\dots\dots(2)$$

L_{10m}	: Modified nominal life	(rev.)
α	: Modified factor	
C_a	: Basic dynamic load rating	(N)
F_a	: Axial load	(N)

● Service Life Time

When the nominal life (L_{10}) has been obtained, the service life time is obtained using the following equation (if the stroke length and the number of reciprocations per minute are constant).

$$L_h = \frac{L_{10} \cdot \ell}{2 \cdot \ell_s \cdot n_1 \times 60}$$

L_h	: Service life time	(h)
ℓ_s	: Stroke length	(mm)
n_1	: Number of reciprocations per minute	(min ⁻¹)
ℓ	: Ball screw lead	(mm)

■f_c: Contact Factor

If two inner blocks are used in close contact with each other with model KR-B/D, multiply the basic load rating by the corresponding contact factor indicated in Table7.

Table7 Contact Factor (f_c)

Inner block types	Contact factor f _c
Model KR-B Model KR-D	0.81

■f_w: Load Factor

Table8 shows load factors.

Table8 Load Factor (f_w)

Vibrations/impact	Speed(V)	f _w
Faint	Very low V ≤ 0.25m/s	1 to 1.2
Weak	Slow 0.25 < V ≤ 1m/s	1.2 to 1.5
Medium	Medium 1 < V ≤ 2m/s	1.5 to 2
Strong	High V > 2m/s	2 to 3.5

■K: Moment Equivalent Factor (LM Guide Unit)

When model KR travels under a moment, the distribution of load applied to the LM Guide is locally large (see **A 1-40**). In such cases, calculate the load by multiplying the moment value by the corresponding moment equivalent factor indicated in Table9.

Symbols K_A, K_B and K_C indicate the moment equivalent loads in the M_A, M_B and M_C directions, respectively.

Table9 Equivalent moment factor(K)

Model No.	K _A	K _B	K _C
KR15-A	3.2 × 10 ⁻¹	3.2 × 10 ⁻¹	9.09 × 10 ⁻²
KR15-B	5.96 × 10 ⁻²	5.96 × 10 ⁻²	9.09 × 10 ⁻²
KR20-A	2.4 × 10 ⁻¹	2.4 × 10 ⁻¹	7.69 × 10 ⁻²
KR20-B	4.26 × 10 ⁻²	4.26 × 10 ⁻²	7.69 × 10 ⁻²
KR26-A	1.73 × 10 ⁻¹	1.73 × 10 ⁻¹	5.88 × 10 ⁻²
KR26-B	3.06 × 10 ⁻²	3.06 × 10 ⁻²	5.88 × 10 ⁻²
KR30H-A	1.51 × 10 ⁻¹	1.51 × 10 ⁻¹	4.78 × 10 ⁻²
KR30H-B	2.76 × 10 ⁻²	2.76 × 10 ⁻²	4.78 × 10 ⁻²
KR30H-C	2.77 × 10 ⁻¹	2.77 × 10 ⁻¹	4.78 × 10 ⁻²
KR30H-D	3.99 × 10 ⁻²	3.99 × 10 ⁻²	4.78 × 10 ⁻²
KR33-A	1.51 × 10 ⁻¹	1.51 × 10 ⁻¹	4.93 × 10 ⁻²
KR33-B	2.57 × 10 ⁻²	2.57 × 10 ⁻²	4.93 × 10 ⁻²
KR33-C	2.77 × 10 ⁻¹	2.77 × 10 ⁻¹	4.93 × 10 ⁻²
KR33-D	3.55 × 10 ⁻²	3.55 × 10 ⁻²	4.93 × 10 ⁻²
KR45H-A	9.83 × 10 ⁻²	9.83 × 10 ⁻²	3.45 × 10 ⁻²
KR45H-B	1.87 × 10 ⁻²	1.87 × 10 ⁻²	3.45 × 10 ⁻²
KR45H-C	1.83 × 10 ⁻¹	1.83 × 10 ⁻¹	3.45 × 10 ⁻²
KR45H-D	2.81 × 10 ⁻²	2.81 × 10 ⁻²	3.45 × 10 ⁻²
KR46-A	1.01 × 10 ⁻¹	1.01 × 10 ⁻¹	3.38 × 10 ⁻²
KR46-B	1.78 × 10 ⁻²	1.78 × 10 ⁻²	3.38 × 10 ⁻²
KR46-C	1.85 × 10 ⁻¹	1.85 × 10 ⁻¹	3.38 × 10 ⁻²
KR46-D	2.5 × 10 ⁻²	2.5 × 10 ⁻²	3.38 × 10 ⁻²
KR55-A	8.63 × 10 ⁻²	8.63 × 10 ⁻²	2.83 × 10 ⁻²
KR55-B	1.53 × 10 ⁻²	1.53 × 10 ⁻²	2.83 × 10 ⁻²
KR65-A	7.55 × 10 ⁻²	7.55 × 10 ⁻²	2.14 × 10 ⁻²
KR65-B	1.35 × 10 ⁻²	1.35 × 10 ⁻²	2.14 × 10 ⁻²

Note) The values for models KR-B/D indicate the values when double inner blocks are used in close contact with each other.

Accuracy Standards

The accuracy standard of model KR is defined in positioning repeatability, positioning accuracy, running parallelism (vertical direction) and backlash.

[Positioning Repeatability]

Command the position to a given arbitrary point. Measure the position and repeat seven times from the same direction. Record the difference between the largest and smallest values. Conduct the same test at three points: the middle of the stroke, and at both the approximate maximum and minimum positions of travel. Express the maximum difference value of the three measurements divided by 2 with a “±” sign.

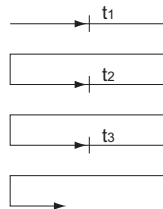

Fig.6 Positioning Repeatability

[Positioning Accuracy]

Using the maximum stroke as the reference length, express the maximum error between the actual distance traveled from the reference point and the command value in an absolute value as positioning accuracy.

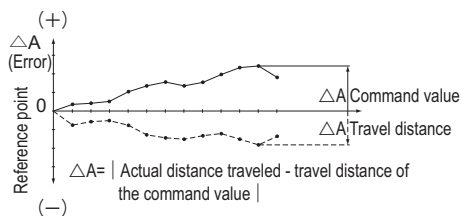

Fig.7 Positioning Accuracy

[Running of Parallelism (Vertical direction)]

Place a straightedge on the surface table where model KR is mounted, measure almost throughout the travel distance of the inner block using a test indicator. Use the maximum difference among the readings within the travel distance as the running parallelism measurement.

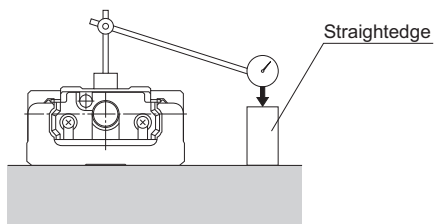

Fig.8 Running of Parallelism

[Backlash]

Feed and slightly move the inner block and read the measurement on the test indicator as the reference value. Subsequently, apply a load to the inner block from the same direction (table feed direction), and then release the inner block from the load. Use the difference between the reference value and the return as the backlash measurement.

Perform this measurement in the center and near both ends, and use the maximum value as the measurement value.

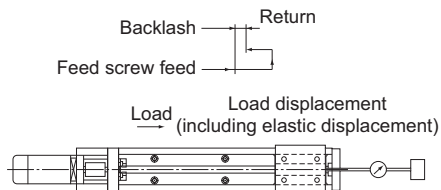

Fig.9 Backlash

The accuracies of model KR are classified into normal grade (no symbol), high accuracy grade (H) and precision grade (P). Tables below show standards for all the accuracies.

Table10 Normal Grade (No Symbol)

Unit: mm

Model No.	Stroke*	Outer rail length	Positioning Repeatability	Positioning Accuracy	Running Parallelism (Vertical Direction)	Backlash	Starting torque (N·cm)
KR20	30	100	±0.01	No standard defined	No standard defined	0.02	0.5
	80	150					
	130	200					
KR26	60	150	±0.01	No standard defined	No standard defined	0.02	1.5
	110	200					
	160	250					
KR30H	210	300	±0.01	No standard defined	No standard defined	0.02	7
	50	150					
	100	200					
	200	300					
	300	400					
KR33	400	500	±0.01	No standard defined	No standard defined	0.02	7
	500	600					
	600	700					
	50	150					
	100	200					
	200	300					
KR45H	300	400	±0.01	No standard defined	No standard defined	0.02	10
	400	540					
	500	640					
	600	740					
	700	840					
	800	940					
KR46	190	340	±0.01	No standard defined	No standard defined	0.02	10
	290	440					
	390	540					
	490	640					
	590	740					
	690	840					
KR55	790	940	±0.01	No standard defined	No standard defined	0.05	12
	800	980					
	900	1080					
	1000	1180					
	1100	1280					
KR65	1200	1380	±0.01	No standard defined	No standard defined	0.05	12
	790	980					
	990	1180					
	1190	1380					
	1490	1680	±0.012				15

*Indicates stroke length when one long-type inner block is incorporated.

Note1) The evaluation method complies with THK standards.

Note2) Measurements are taken while using a motor provided by THK. For motor-wrap configuration, these values may not apply.

Note3) The starting torque represents the value when THK AFB-LF Grease is used. However, that of models KR20 and KR26 represents the value when THK AFA Grease is used, and that of KR15 represents the value when THK AFF Grease is used.

Note4) If highly viscous grease such as vacuum grease and clean room grease is used, the actual starting torque may exceed the corresponding value in the table. Use much care in selecting a motor.

Note5) Contact THK for accuracy information of units longer than the standard length.

Note6) Model KR15 is available in high accuracy grade (H) and precision grade (P) only.

Table11 High Accuracy Grade (H)

Unit: mm

Model No.	Stroke*	Outer rail length	Positioning accuracy repeatability	Positioning Accuracy	Running of Parallelism (Vertical direction)	Backlash	Starting torque (N·cm)				
KR15	25	75	±0.004	0.04	0.02	0.01	0.4				
	50	100									
	75	125									
	100	150									
	125	175									
KR20	150	200	±0.005	0.06	0.025	0.01	0.5				
	30	100									
	80	150									
KR26	130	200	±0.005	0.06	0.025	0.01	1.5				
	60	150									
	110	200									
	160	250									
KR30H	210	300	±0.005	0.06	0.025	0.02	7				
	50	150									
	100	200		0.10	0.035						
	200	300									
	300	400									
KR33	400	500	±0.005	0.06	0.025	0.02	7				
	500	600									
	50	150		0.10	0.035						
	100	200									
	200	300									
	300	400									
KR45H	400	500	±0.005	0.10	0.035	0.02	10				
	500	640									
	600	740		0.12	0.04						
	700	840									
	800	940									
	KR46	190		340	±0.005			0.10	0.035	0.02	10
		290		440							
390		540	0.12	0.04							
490		640									
590		740									
690		840									
KR55	790	940	±0.005	0.18	0.05	0.05	12				
	800	980									
	900	1080		0.25	0.05						
	1000	1180									
	1100	1280									
KR65	1200	1380	±0.008	0.18	0.05	0.05	12				
	790	980									
	990	1180		0.20	0.055						
	1190	1380									
	1490	1680		0.28			15				

*Indicates stroke length when one long-type inner block is incorporated.

Note1) The evaluation method for accuracy standards complies with THK standards.

Note2) Measurements are taken while using a motor provided by THK. For motor-wrap configurations, these values may not apply.

Note3) The starting torque refers to the values when THK AFB-LF Grease is used. However, the values for KR15 refer to the values when using THK AFF Grease.

Note4) If highly viscous grease such as vacuum grease and clean room grease is used, the actual starting torque may exceed the corresponding value in the table. Use great care in selecting a motor.

Note5) Contact THK for accuracy information of units longer than the standard length.

Table12 Precision Grade (P)

Unit: mm

Model No.	Stroke*	Outer rail length	Positioning accuracy repeatability	Positioning Accuracy	Running of Parallelism (Vertical direction)	Backlash	Starting torque (N·cm)
KR15	25	75	±0.003	0.02	0.01	0.002	0.8
	50	100					
	75	125					
	100	150					
	125	175					
KR20	150	200	±0.003	0.02	0.01	0.003	1.2
	30	100					
	80	150					
KR26	130	200	±0.003	0.02	0.01	0.003	4
	60	150					
	110	200					
	160	250					
KR30H	210	300	±0.003	0.02	0.01	0.003	15
	50	150					
	100	200		0.025	0.015		
	200	300					
	300	400					
KR33	400	500	±0.003	0.02	0.01	0.003	15
	500	600					
	50	150		0.025	0.015		
	100	200					
	200	300					
	KR45H	300		400	±0.003		
400		540					
600		740	0.03	0.02		17	
700		840					
KR46	800	940	±0.005	0.035	0.025	0.003	17
	190	340					
	290	440	±0.003	0.025	0.015		
	390	540					
	490	640					
	590	740	±0.005	0.035	0.025		
	690	840					
790	940						
KR55	800	980	±0.005	0.035	0.025	0.003	17
	900	1080					
	1000	1180		0.04	0.03		20
KR65	790	980	±0.005	0.035	0.025	0.005	20
	990	1180					
	1190	1380		0.04	0.03		22

*Indicates stroke length when one long-type inner block is incorporated.

Note1) The evaluation method complies with THK standards.

Note2) Measurements are taken while using a motor provided by THK. For motor-wrap configuration, these values may not apply.

Note3) The starting torque represents the value when THK AFB-LF Grease is used.

However, that of models KR20 and KR26 represents the value when THK AFA Grease is used, and that of KR15 represents the value when THK AFF Grease is used.

Note4) If highly viscous grease such as vacuum grease and clean room grease is used, the actual starting torque may exceed the corresponding value in the table. Use much care in selecting a motor.

Note5) Contact THK for accuracy information of units longer than the standard length.

Model Number Coding

Model No.	Ball screw lead	Inner block type	QZ specification	Stroke	Accuracy grade
KR33	10	A	QZ	0275	P
①	②	③	④	⑤	⑥

KR15	01: 1 mm	A	No symbol : No QZ	0020: 20 mm	No symbol: Normal grade
KR20	02: 2 mm	B	QZ	0025: 25 mm	H: High accuracy grade
KR26	06: 6 mm	C	QZA	}	P: Precision grade
KR30H	10: 10 mm	D	QZB	1490: 1490 mm	
KR33	20: 20 mm		QZAD		
KR45H	25: 25 mm				
KR46					
KR55					
KR65					

QZ specification ④ can be selected on the following models.

KR33 (→ **A2-158**)

KR46 (→ **A2-174**)

KR55 (→ **A2-182**)

KR65 (→ **A2-188**)

*It cannot be selected for KR15, KR20, KR26, KR30H and KR45H.

If QZ, QZA, QZB, or QZAD is selected for QZ specification ④, specify a stroke incorporating QZ. (→ **A2-193**)

If "2: with a bellows" has been selected for Cover ⑧, specify a stroke incorporating the bellows. (→ **A2-204**)

The available ball screw leads differ depending on the model.

KR15: "01," "02"

KR20: "01," "06"

KR26: "02," "06"

KR30H: "06," "10"

KR33: "06," "10"

KR45H: "10," "20"

KR46: "10," "20"

KR55: "20"

KR65: "25"

With/without a motor

0

⑦

With direct coupling
0: Direct coupling (without motor)
1: Direct coupling (THK will purchase and mount the motor you specify)
With motor wrap
R1: Non-standard side wrap (without motor)
R2: Standard side wrap (without motor)
R3: Bottom side wrap (without motor)
R4: Non-standard side wrap (THK will purchase and mount the motor you specify)
R5: Standard side wrap (THK will purchase and mount the motor you specify)
R6: Bottom side wrap (THK will purchase and mount the motor you specify)

Cover

1

⑧

0: Without cover
1: With cover
2: With bellows

Sensor

B

⑨

0: None
1
2
6
7
B
E
H
L
J
M

Housing A/
Intermediate flange**AQ**

⑩

0: Without cover	0: None	With direct coupling	With motor wrap
1: With cover	1	A0	WN-05D
2: With bellows	2	AN	WP-08D
	6	AP	WP-08K
	7	AQ	WP-08M
	B	AR	WQ-08D
	E	AS	WQ-08K
	H	AT	WQ-08M
	L	AU	WV-14M
	J	AV	WY-11M
	M	AY	WY-14M
		AZ	WZ-16M
		A5	WZ-19M
		A6	W5-19M
		10	
		20	
		30	
		40	
		60	

If QZ specification ④ "QZ," "QZA," "QZB," or "QZAD" is selected, "2: With bellows" cannot be selected.

If "0" is selected:

No coupling will be attached. Please specify if a coupling is required when ordering.

If "R1," "R2," or "R3" is selected:

A timing pulley and timing belt will be included.

If "1," "R4," "R5," or "R6" is selected:

The designated motor will be mounted. Please specify the motor cable direction separately.

Please select an option for ⑩ Housing A/Intermediate flange that matches the specified motor.

This product is compatible with motors from various manufacturers. Contact THK for details.

⑦ Motor wrap direction

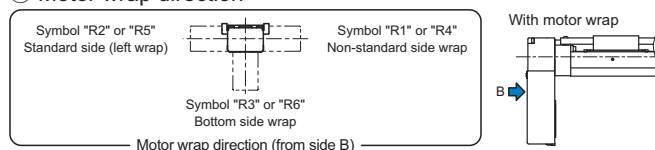

KR15 Without Cover, Direct Motor Coupling

Model KR15□□A (with a Single Long Nut Block)

Model KR15□□B (with Two Long Nut Blocks)

For model number coding, see **A2-136**.

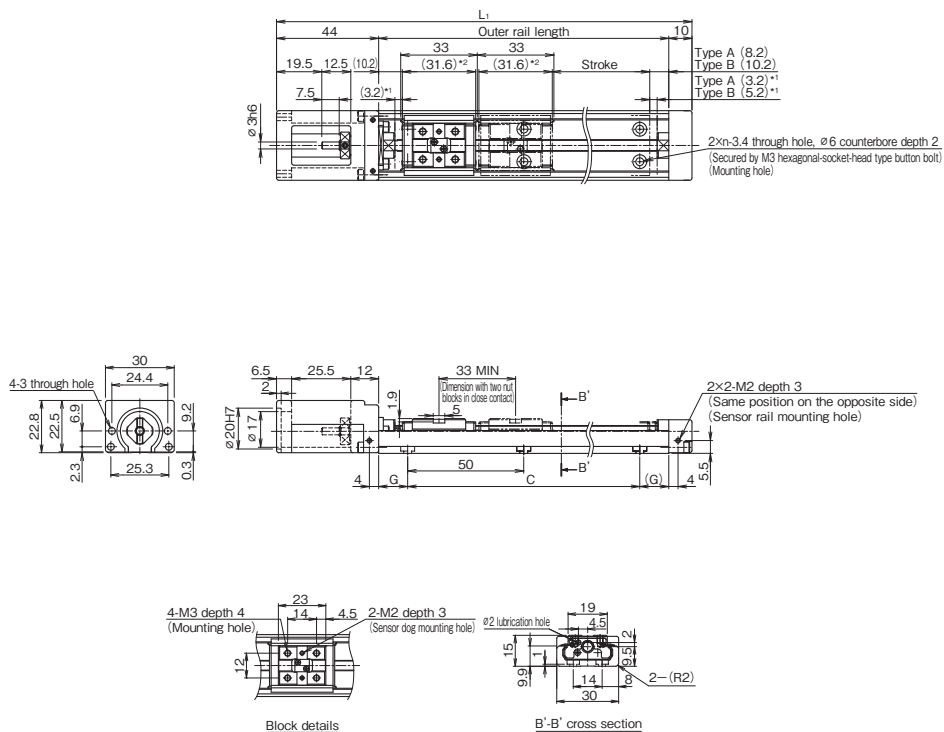

*1 Distance between the mechanical stopper and the stroke starting position.

*2 This indicates the block length when calculating the possible stroke range.

It is 64.6 mm (total) for a KR15 with 2 blocks in close contact with each other (B type).

Stroke (mm) (stroke between mechanical stoppers)		Outer rail length (mm)	Overall length L_1 (mm)	C (mm)	G (mm)	n	Overall main unit mass (kg)	
Type A	Type B*						Type A	Type B
25 (31.4)	—	75	129	50	12.5	2	0.2	—
50 (56.4)	—	100	154	50	25	2	0.23	—
75 (81.4)	40 (48.4)	125	179	100	12.5	3	0.26	0.3
100 (106.4)	65 (73.4)	150	204	100	25	3	0.29	0.33
125 (131.4)	90 (98.4)	175	229	150	12.5	4	0.32	0.36
150 (156.4)	115 (123.4)	200	254	150	25	4	0.35	0.39

*Indicates a value when two inner blocks are in close contact with each other.

KR15 With Cover, Direct Motor Coupling

Model KR15□□A (with a Single Long Nut Block)

Model KR15□□B (with Two Long Nut Blocks)

For model number coding, see **A2-136**.

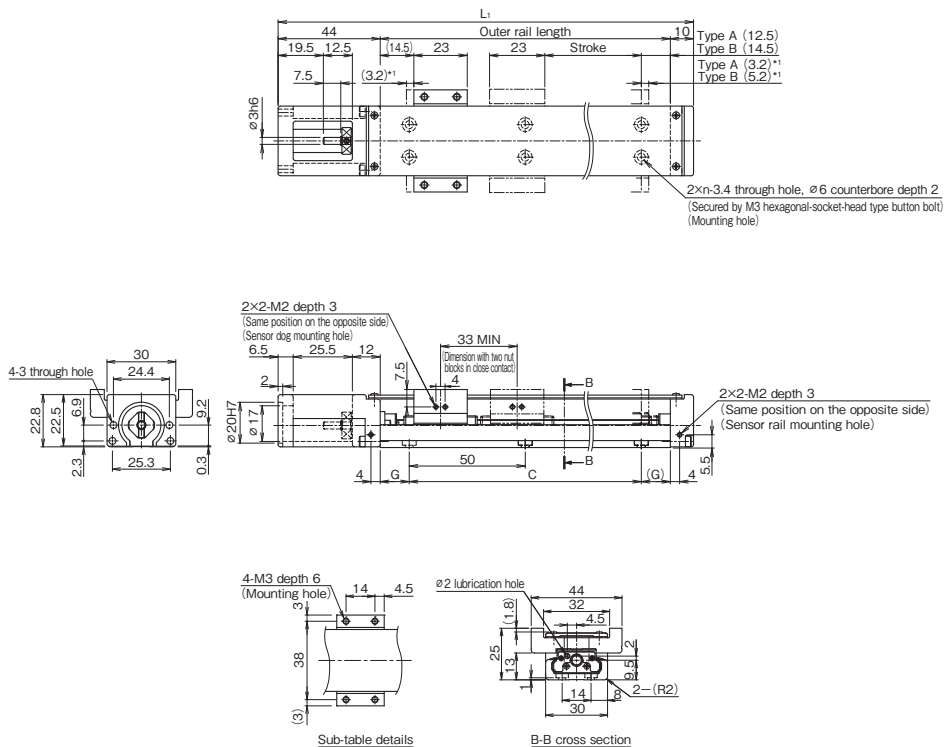

^{*1} Distance between the mechanical stopper and the stroke starting position.

^{*2} This indicates the block length when calculating the possible stroke range.

It is 64.6 mm (total) for a KR15 with 2 blocks in close contact with each other (B type).

Stroke (mm) (stroke between mechanical stoppers)		Outer rail length (mm)	Overall length L_1 (mm)	C (mm)	G (mm)	n	Overall main unit mass (kg)	
Type A	Type B [*]						Type A	Type B
25 (31.4)	—	75	129	50	12.5	2	0.25	—
50 (56.4)	—	100	154	50	25	2	0.28	—
75 (81.4)	40 (48.4)	125	179	100	12.5	3	0.32	0.39
100 (106.4)	65 (73.4)	150	204	100	25	3	0.35	0.42
125 (131.4)	90 (98.4)	175	229	150	12.5	4	0.38	0.45
150 (156.4)	115 (123.4)	200	254	150	25	4	0.41	0.48

^{*}Indicates a value when two inner blocks are in close contact with each other.

KR15 Without Cover, Motor Wrap

Model KR15□□A (with a Single Long Nut Block)

Model KR15□□B (with Two Long Nut Blocks)

For model number coding, see **A2-136**.

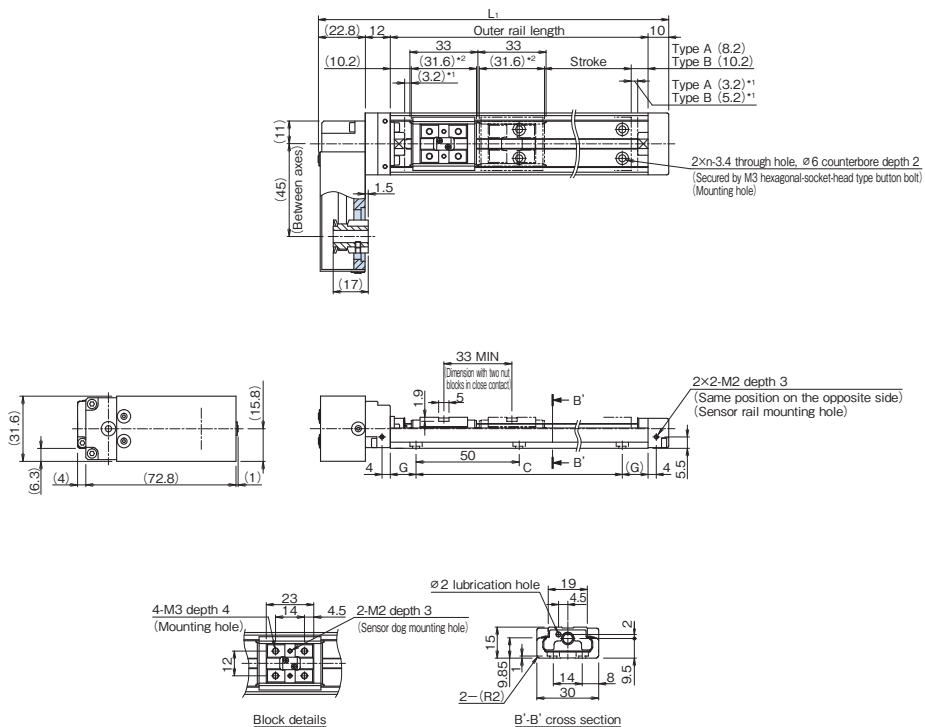

*1 Distance between the mechanical stopper and the stroke starting position.

*2 This indicates the block length when calculating the possible stroke range.

It is 64.6 mm (total) for a KR15 with 2 blocks in close contact with each other (B type).

Stroke (mm) (stroke between mechanical stoppers)		Outer rail length (mm)	Overall length L ₁ (mm)	C (mm)	G (mm)	n	Overall main unit mass (kg)	
Type A	Type B*						Type A	Type B
25 (31.4)	—	75	119.8	50	12.5	2	0.38	—
50 (56.4)	—	100	144.8	50	25	2	0.41	—
75 (81.4)	40 (48.4)	125	169.8	100	12.5	3	0.44	0.48
100 (106.4)	65 (73.4)	150	194.8	100	25	3	0.47	0.51
125 (131.4)	90 (98.4)	175	219.8	150	12.5	4	0.5	0.54
150 (156.4)	115 (123.4)	200	244.8	150	25	4	0.53	0.57

*Indicates a value when two inner blocks are in close contact with each other.

KR15 With Cover, Motor Wrap

Model KR15□□A (with a Single Long Nut Block)

Model KR15□□B (with Two Long Nut Blocks)

For model number coding, see **A2-136**.

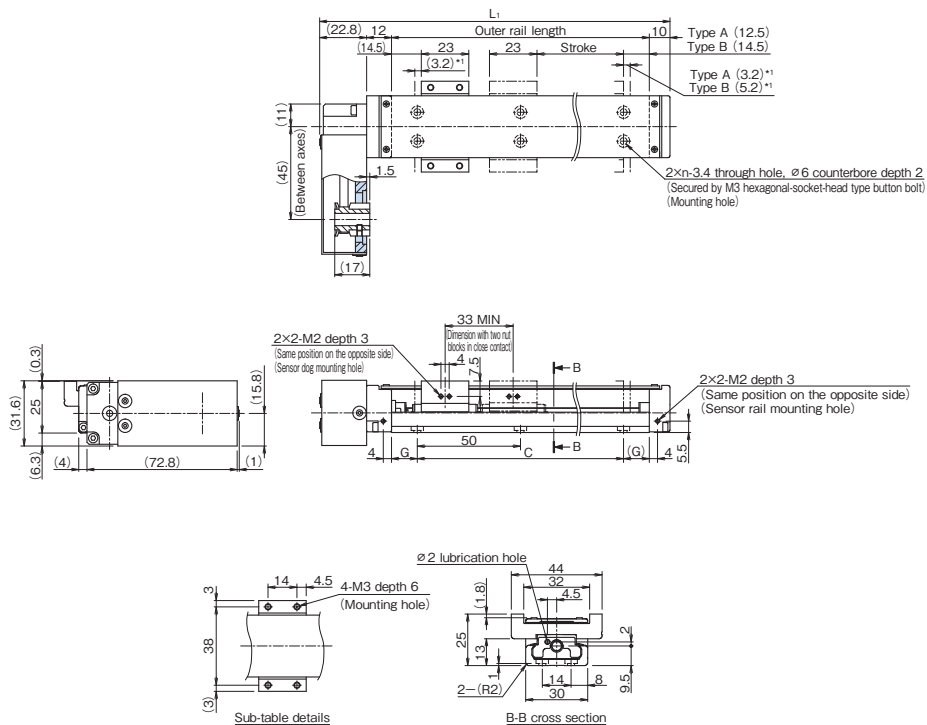

*1 Distance between the mechanical stopper and the stroke starting position.

*2 This indicates the block length when calculating the possible stroke range. It is 64.6 mm (total) for a KR15 with 2 blocks in close contact with each other (B type).

Stroke (mm) (stroke between mechanical stoppers)		Outer rail length (mm)	Overall length L ₁ (mm)	C (mm)	G (mm)	n	Overall main unit mass (kg)	
Type A	Type B ¹						Type A	Type B
25 (31.4)	—	75	119.8	50	12.5	2	0.43	—
50 (56.4)	—	100	144.8	50	25	2	0.46	—
75 (81.4)	40 (48.4)	125	169.8	100	12.5	3	0.49	0.56
100 (106.4)	65 (73.4)	150	194.8	100	25	3	0.53	0.6
125 (131.4)	90 (98.4)	175	219.8	150	12.5	4	0.56	0.63
150 (156.4)	115 (123.4)	200	244.8	150	25	4	0.59	0.66

¹Indicates a value when two inner blocks are in close contact with each other.

KR20 Without Cover, Direct Motor Coupling

Model KR20□□A (with a Single Long Nut Block)

Model KR20□□B (with Two Long Nut Blocks)

For model number coding, see **A2-136**.

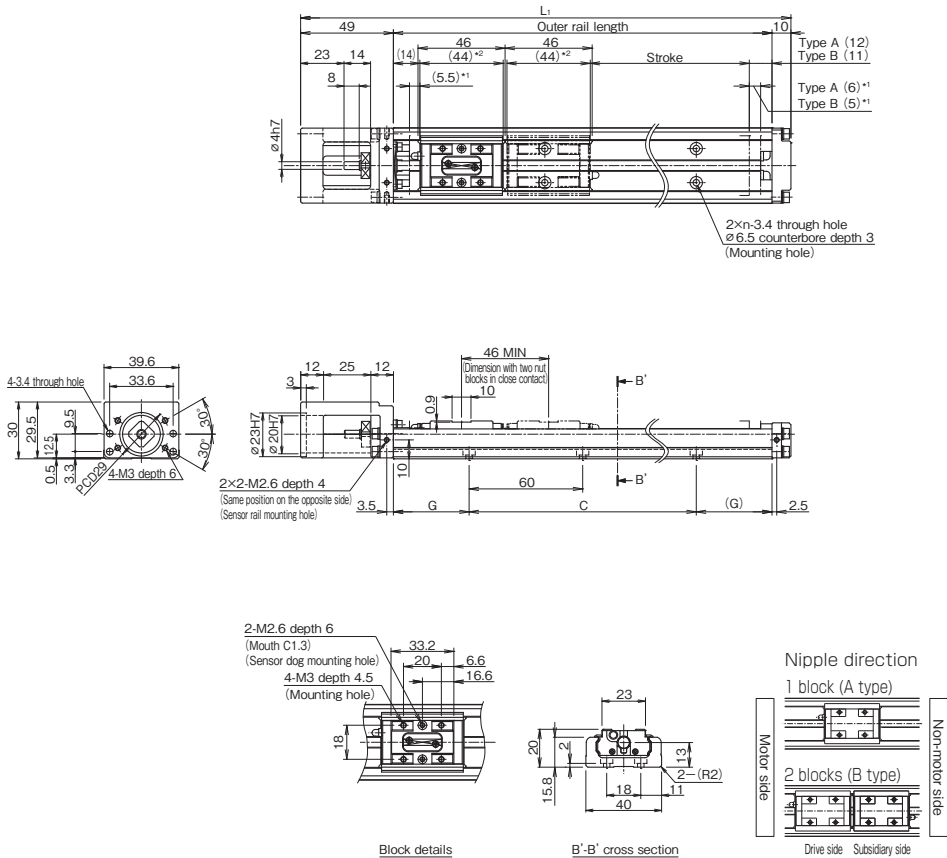

*1 Distance between the mechanical stopper and the stroke starting position.

*2 This indicates the block length when calculating the possible stroke range.
It is 90 mm (total) for a KR20 with 2 blocks in close contact with each other (B type).

Stroke (mm) (stroke between mechanical stoppers)		Outer rail length (mm)	Overall length L ₁ (mm)	C (mm)	G (mm)	n	Overall main unit mass (kg)	
Type A	Type B*						Type A	Type B
30 (41.5)	—	100	159	60	20	2	0.48	—
80 (91.5)	35 (45.5)	150	209	120	15	3	0.61	0.69
130 (141.5)	85 (95.5)	200	259	120	40	3	0.75	0.83

*Indicates a value when two inner blocks are in close contact with each other.

KR20 With Cover, Direct Motor Coupling

Model KR20□□A (with a Single Long Nut Block)

Model KR20□□B (with Two Long Nut Blocks)

For model number coding, see **A2-136**.

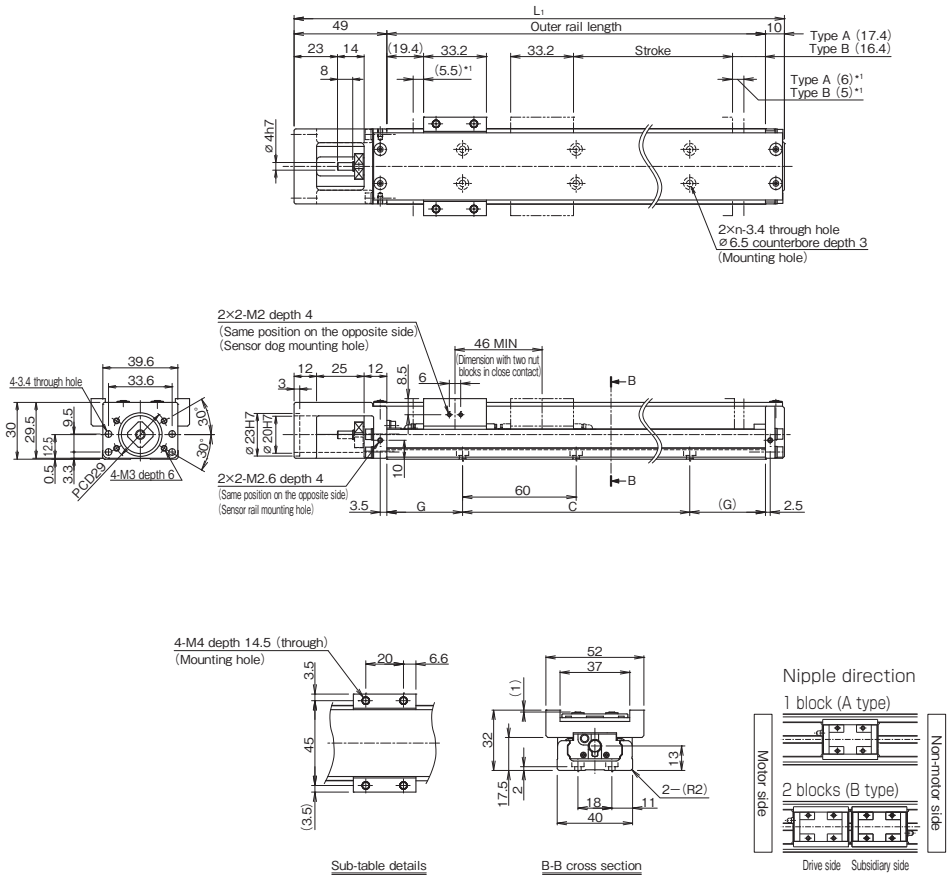

*1 Distance between the mechanical stopper and the stroke starting position.

Stroke (mm) (stroke between mechanical stoppers)		Outer rail length (mm)	Overall length L ₁ (mm)	C (mm)	G (mm)	n	Overall main unit mass (kg)	
Type A	Type B						Type A	Type B
30 (41.5)	—	100	159	60	20	2	0.56	—
80 (91.5)	35 (45.5)	150	209	120	15	3	0.71	0.84
130 (141.5)	85 (95.5)	200	259	120	40	3	0.85	0.98

*Indicates a value when two inner blocks are in close contact with each other.

KR20 Without Cover, Motor Wrap

Model KR20□□A (with a Single Long Nut Block)

Model KR20□□B (with Two Long Nut Blocks)

For model number coding, see **A2-136**.

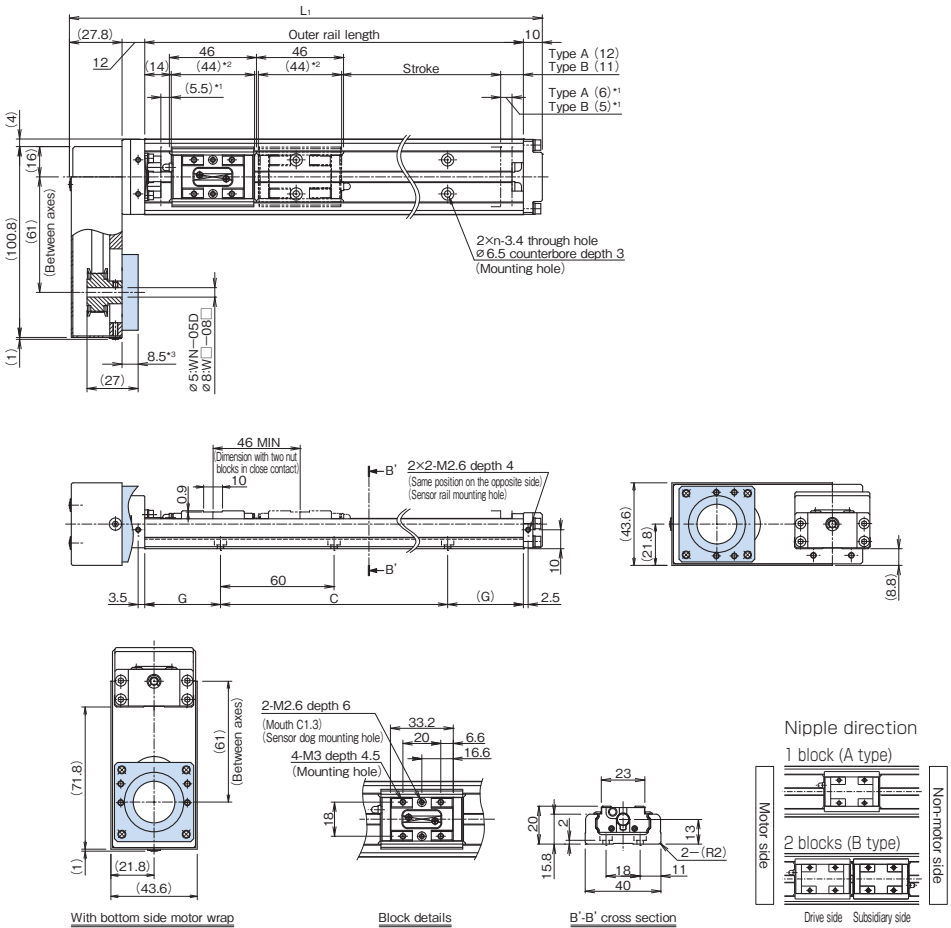

*1 Distance between the mechanical stopper and the stroke starting position.

*2 This indicates the block length when calculating the possible stroke range.

It is 90 mm (total) for a KR20 with 2 blocks in close contact with each other (B type).

*3 Dimensions will vary if "WN" is selected for model number coding H Housing A/Intermediate flange.
For details, see **A2-227**.

Stroke (mm) (stroke between mechanical stoppers)		Outer rail length (mm)	Overall length L_1 (mm)	C (mm)	G (mm)	n	Overall main unit mass (kg)	
Type A	Type B						Type A	Type B
30 (41.5)	—	100	149.8	60	20	2	0.73	—
80 (91.5)	35 (45.5)	150	199.8	120	15	3	0.87	0.95
130 (141.5)	85 (95.5)	200	249.8	120	40	3	1.01	1.09

*Indicates a value when two inner blocks are in close contact with each other.

KR20 With Cover, Motor Wrap

Model KR20□□A (with a Single Long Nut Block)

Model KR20□□B (with Two Long Nut Blocks)

For model number coding, see **A2-136**.

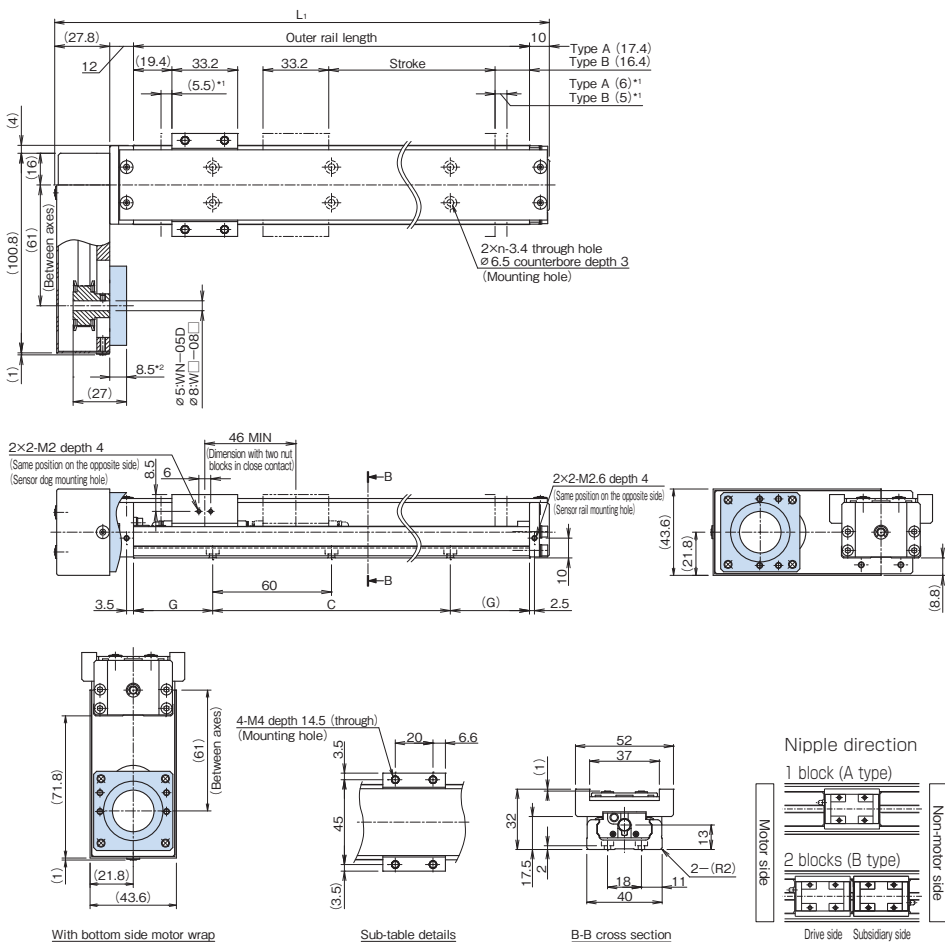

*1 Distance between the mechanical stopper and the stroke starting position.

*2 Dimensions will vary if "1WN" is selected for model number coding (Housing A/Intermediate flange). For details, see **A2-227**.

Stroke (mm) (stroke between mechanical stoppers)		Outer rail length (mm)	Overall length L_1 (mm)	C (mm)	G (mm)	n	Overall main unit mass (kg)	
Type A	Type B*						Type A	Type B
30 (41.5)	—	100	149.8	60	20	2	0.82	—
80 (91.5)	35 (45.5)	150	199.8	120	15	3	0.96	1.09
130 (141.5)	85 (95.5)	200	249.8	120	40	3	1.11	1.24

*Indicates a value when two inner blocks are in close contact with each other.

KR26 Without Cover, Direct Motor Coupling

Model KR26□□A (with a Single Long Nut Block)

Model KR26□□B (with Two Long Nut Blocks)

For model number coding, see **A2-136**.

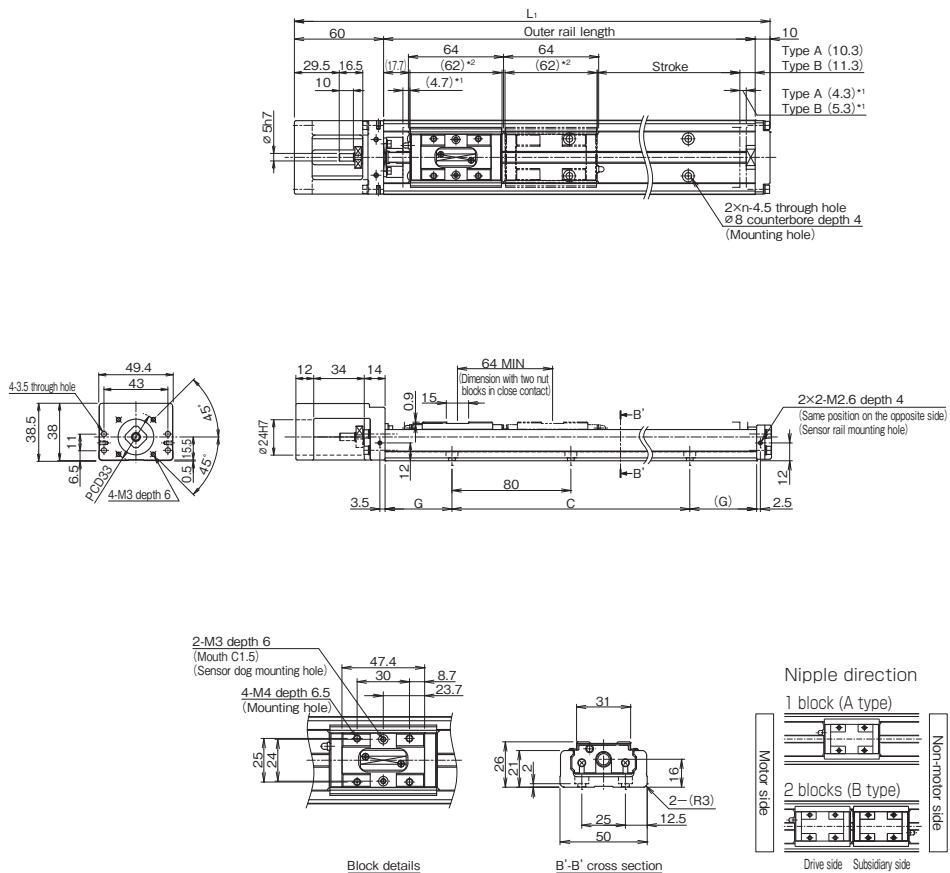

*1 Distance between the mechanical stopper and the stroke starting position.

*2 This indicates the block length when calculating the possible stroke range.
It is 126 mm (total) for a KR26 with 2 blocks in close contact with each other (B type).

Stroke (mm) (stroke between mechanical stoppers)		Outer rail length (mm)	Overall length L_1 (mm)	C (mm)	G (mm)	n	Overall main unit mass (kg)	
Type A	Type B*						Type A	Type B
60 (69)	—	150	220	80	35	2	1.04	—
110 (119)	45 (55)	200	270	160	20	3	1.25	1.44
160 (169)	95 (105)	250	320	160	45	3	1.46	1.65
210 (219)	145 (155)	300	370	240	30	4	1.67	1.86

*Indicates a value when two inner blocks are in close contact with each other.

KR26 With Cover, Direct Motor Coupling

Model KR26□□A (with a Single Long Nut Block)

Model KR26□□B (with Two Long Nut Blocks)

For model number coding, see **A2-136**.

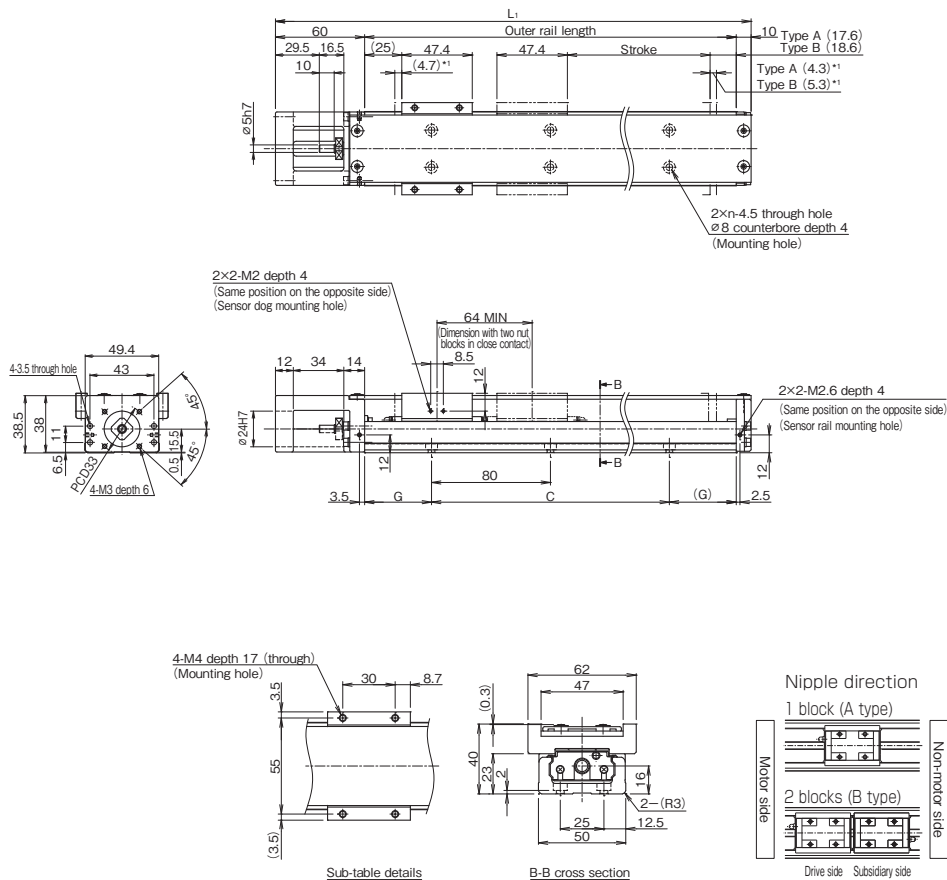

*1 Distance between the mechanical stopper and the stroke starting position.

Stroke (mm) (stroke between mechanical stoppers)		Outer rail length (mm)	Overall length L ₁ (mm)	C (mm)	G (mm)	n	Overall main unit mass (kg)	
Type A	Type B*						Type A	Type B
60 (69)	—	150	220	80	35	2	1.2	—
110 (119)	45 (55)	200	270	160	20	3	1.42	1.7
160 (169)	95 (105)	250	320	160	45	3	1.65	1.93
210 (219)	145 (155)	300	370	240	30	4	1.87	2.15

*Indicates a value when two inner blocks are in close contact with each other.

KR26 Without Cover, Motor Wrap

Model KR26□□A (with a Single Long Nut Block)

Model KR26□□B (with Two Long Nut Blocks)

For model number coding, see **A2-136**.

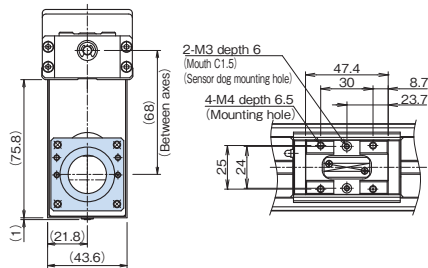
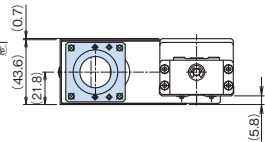
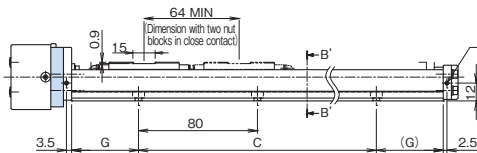
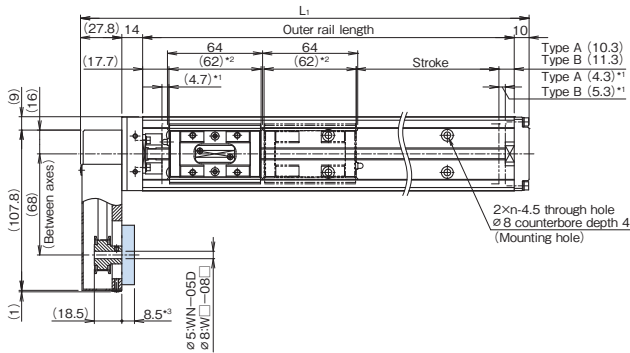

With bottom side motor wrap

Block details

B'-B' cross section

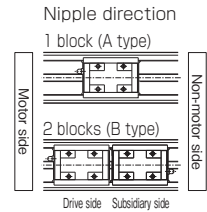

*1 Distance between the mechanical stopper and the stroke starting position.

*2 This indicates the block length when calculating the possible stroke range.

It is 126 mm (total) for a KR26 with 2 blocks in close contact with each other (B type).

*3 Dimensions will vary if "WN" is selected for model number coding. ϕ Housing A/Intermediate flange. For details, see **A2-230**.

Stroke (mm) (stroke between mechanical stoppers)		Outer rail length (mm)	Overall length L ₁ (mm)	C (mm)	G (mm)	n	Overall main unit mass (kg)	
Type A	Type B*						Type A	Type B
60 (69)	—	150	201.8	80	35	2	1.26	—
110 (119)	45 (55)	200	251.8	160	20	3	1.47	1.66
160 (169)	95 (105)	250	301.8	160	45	3	1.69	1.88
210 (219)	145 (155)	300	351.8	240	30	4	1.9	2.09

*Indicates a value when two inner blocks are in close contact with each other.

KR26 With Cover, Motor Wrap

Model KR26□□A (with a Single Long Nut Block)

Model KR26□□B (with Two Long Nut Blocks)

For model number coding, see **A2-136**.

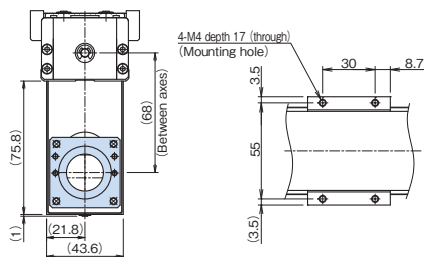
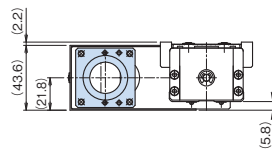
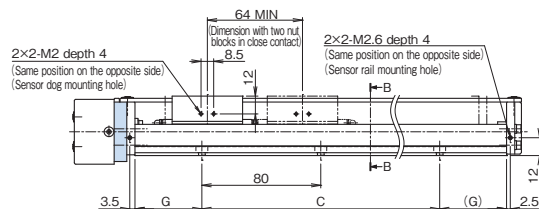
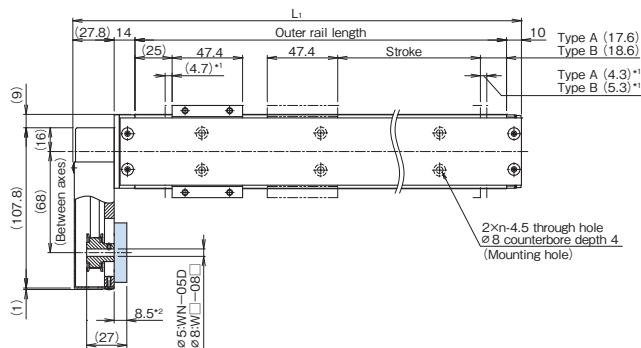

With bottom side motor wrap

Sub-table details

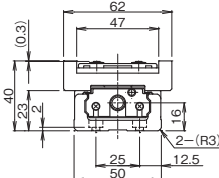

B-B cross section

Nipple direction

1 block (A type)

2 blocks (B type)

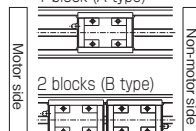

Drive side

^{*1} Distance between the mechanical stopper and the stroke starting position.

^{*2} Dimensions will vary if "WN" is selected for model number coding. ^W Housing A/intermediate flange. For details, see **A2-230**.

Stroke (mm) (stroke between mechanical stoppers)		Outer rail length (mm)	Overall length L_1 (mm)	C (mm)	G (mm)	n	Overall main unit mass (kg)	
Type A	Type B [*]						Type A	Type B
60 (69)	—	150	201.8	80	35	2	1.43	—
110 (119)	45 (55)	200	251.8	160	20	3	1.65	1.93
160 (169)	95 (105)	250	301.8	160	45	3	1.87	2.15
210 (219)	145 (155)	300	351.8	240	30	4	2.1	2.38

^{*}Indicates a value when two inner blocks are in close contact with each other.

KR30H Without Cover, Direct Motor Coupling

Model KR30H□□A (with a Single Long Nut Block)

Model KR30H□□B (with Two Long Nut Blocks)

For model number coding, see **A2-136**.

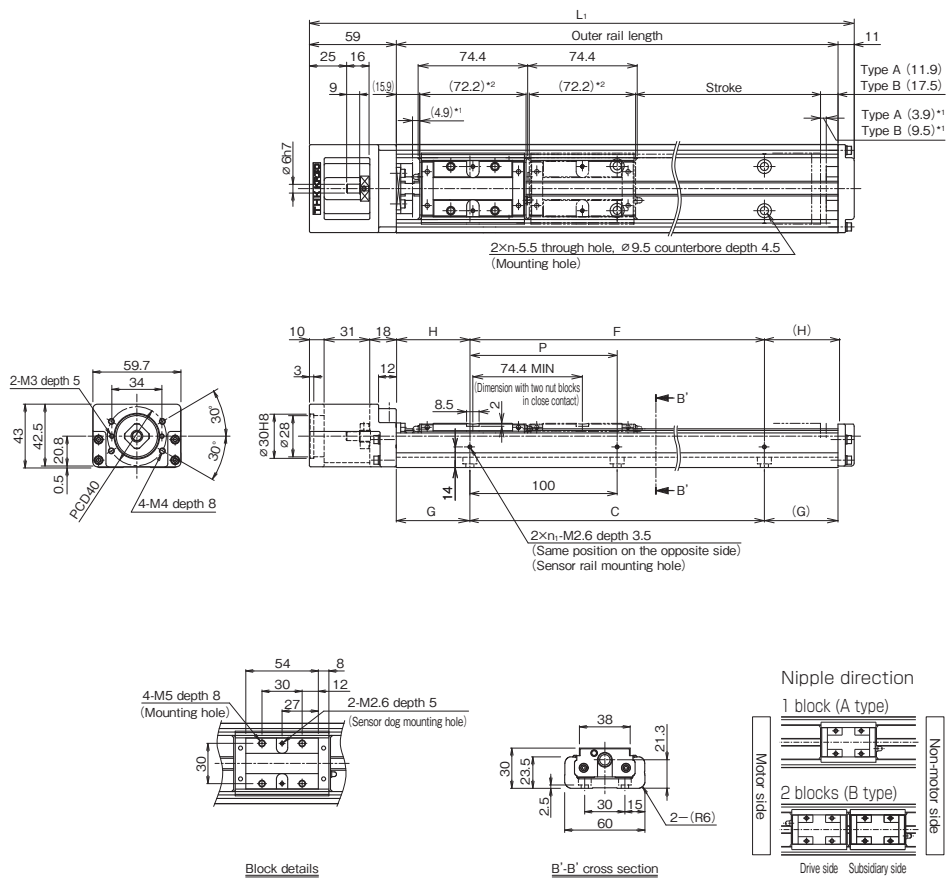

Block details

B-B' cross section

*1 Distance between the mechanical stopper and the stroke starting position.

*2 This indicates the block length when calculating the possible stroke range.

It is 146.6 mm (total) for a KR30H with 2 blocks in close contact with each other (B type).

Stroke (mm) (stroke between mechanical stoppers)		Outer rail length (mm)	Overall length L ₁ (mm)	C (mm)	G (mm)	P (mm)	F (mm)	H (mm)	n	n ₁	Overall main unit mass (kg)	
Type A	Type B*										Type A	Type B
50 (58.8)	—	150	220	100	25	100	100	25	2	2	1.6	—
100 (108.8)	—	200	270	100	50	100	100	50	2	2	1.9	—
200 (208.8)	120 (134.4)	300	370	200	50	200	200	50	3	2	2.5	2.9
300 (308.8)	220 (234.4)	400	470	300	50	200	200	100	4	2	3	3.4
400 (408.8)	320 (334.4)	500	570	400	50	200	400	50	5	3	3.6	4
500 (508.8)	420 (434.4)	600	670	500	50	200	400	100	6	3	4.2	4.6

*Indicates a value when two inner blocks are in close contact with each other.

KR30H With Cover, Direct Motor Coupling

Model KR30H□□A (with a Single Long Nut Block)

Model KR30H□□B (with Two Long Nut Blocks)

For model number coding, see **A2-136**.

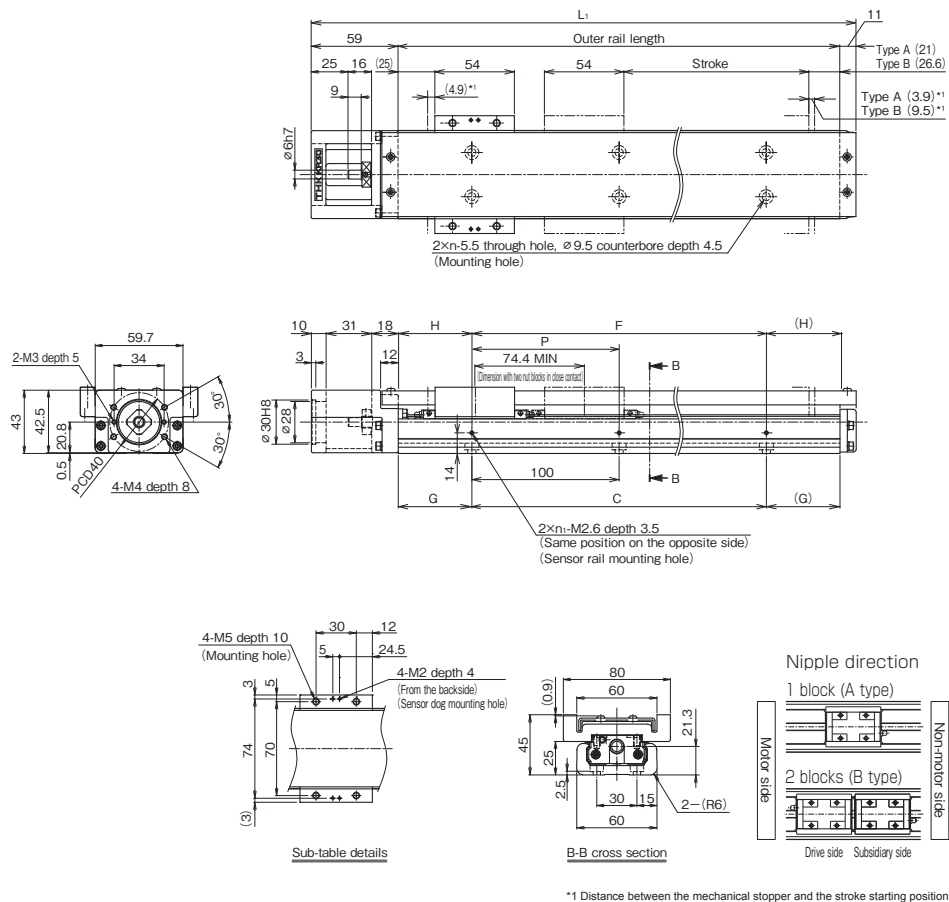

Stroke (mm) (stroke between mechanical stoppers)		Outer rail length (mm)	Overall length L ₁ (mm)	C (mm)	G (mm)	P (mm)	F (mm)	H (mm)	n	n ₁	Overall main unit mass (kg)	
Type A	Type B*										Type A	Type B
50 (58.8)	—	150	220	100	25	100	100	25	2	2	1.9	—
100 (108.8)	—	200	270	100	50	100	100	50	2	2	2.2	—
200 (208.8)	120 (134.4)	300	370	200	50	200	200	50	3	2	2.8	3.4
300 (308.8)	220 (234.4)	400	470	300	50	200	200	100	4	2	3.4	4
400 (408.8)	320 (334.4)	500	570	400	50	200	400	50	5	3	4	4.6
500 (508.8)	420 (434.4)	600	670	500	50	200	400	100	6	3	4.6	5.2

*Indicates a value when two inner blocks are in close contact with each other.

KR30H Without Cover, Motor Wrap

Model KR30H□□A (with a Single Long Nut Block)

Model KR30H□□B (with Two Long Nut Blocks)

For model number coding, see **A2-136**.

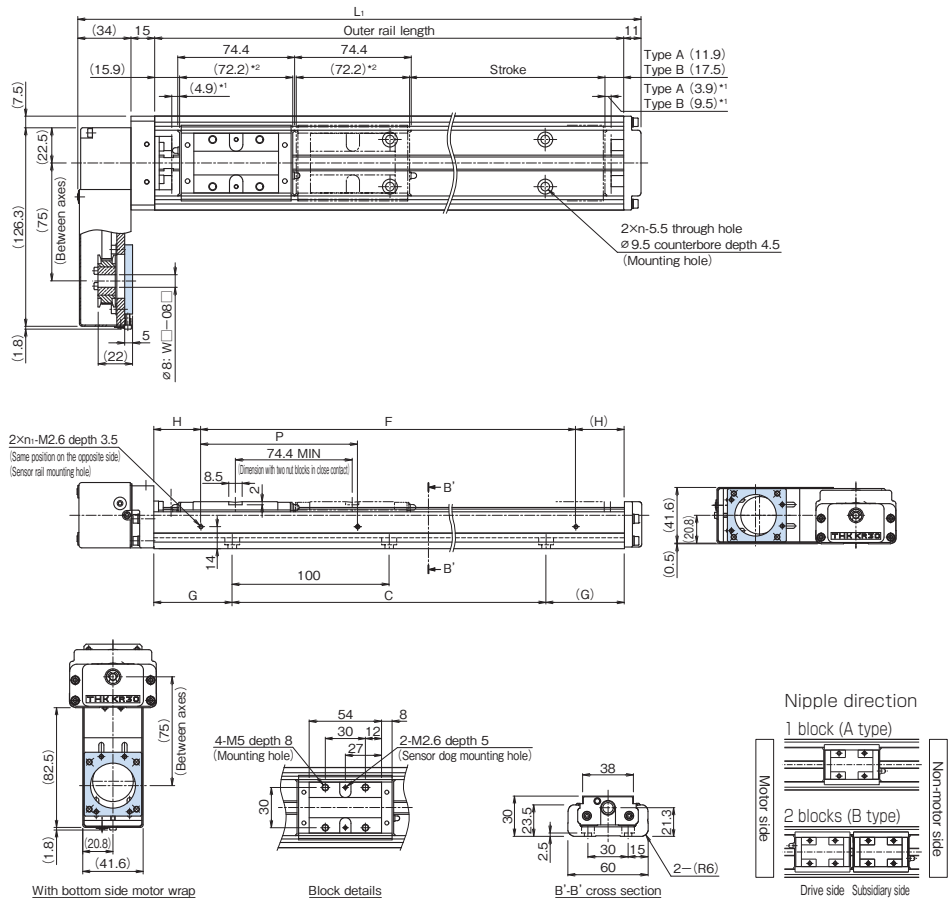

*1 Distance between the mechanical stopper and the stroke starting position.

*2 This indicates the block length when calculating the possible stroke range.

It is 146.6 mm (total) for a KR30H with 2 blocks in close contact with each other (B type).

Stroke (mm) (stroke between mechanical stoppers)		Outer rail length (mm)	Overall length L ₁ (mm)	C (mm)	G (mm)	P (mm)	F (mm)	H (mm)	n	n ₁	Overall main unit mass (kg)	
Type A	Type B*										Type A	Type B
50 (58.8)	—	150	210	100	25	100	100	25	2	2	1.9	—
100 (108.8)	—	200	260	100	50	100	100	50	2	2	2.2	—
200 (208.8)	120 (134.4)	300	360	200	50	200	200	50	3	2	2.8	3.2
300 (308.8)	220 (234.4)	400	460	300	50	200	200	100	4	2	3.4	3.8
400 (408.8)	320 (334.4)	500	560	400	50	200	400	50	5	3	3.9	4.3
500 (508.8)	420 (434.4)	600	660	500	50	200	400	100	6	3	4.5	4.9

*Indicates a value when two inner blocks are in close contact with each other.

KR30H With Cover, Motor Wrap

Model KR30H□□A (with a Single Long Nut Block)

Model KR30H□□B (with Two Long Nut Blocks)

For model number coding, see **A2-136**.

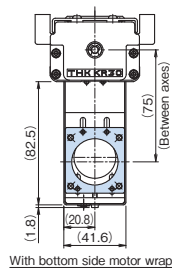
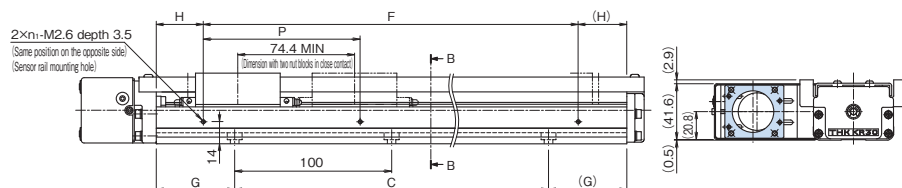
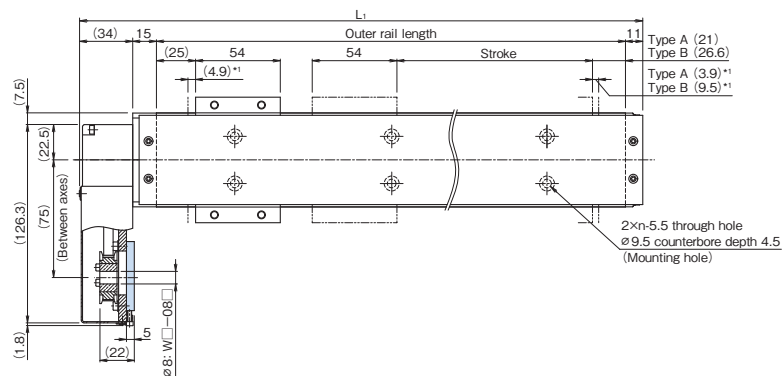

With bottom side motor wrap

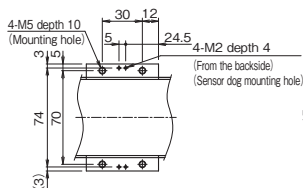

Sub-table details

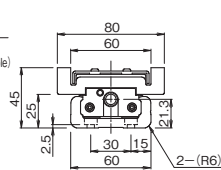

B-B cross section

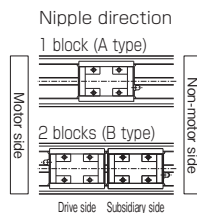

*1 Distance between the mechanical stopper and the stroke starting position.

Stroke (mm) (stroke between mechanical stoppers)		Outer rail length (mm)	Overall length L ₁ (mm)	C (mm)	G (mm)	P (mm)	F (mm)	H (mm)	n	n ₁	Overall main unit mass (kg)	
Type A	Type B*										Type A	Type B
50 (58.8)	—	150	210	100	25	100	100	25	2	2	2.2	—
100 (108.8)	—	200	260	100	50	100	100	50	2	2	2.5	—
200 (208.8)	120 (134.4)	300	360	200	50	200	200	50	3	2	3.1	3.7
300 (308.8)	220 (234.4)	400	460	300	50	200	200	100	4	2	3.7	4.3
400 (408.8)	320 (334.4)	500	560	400	50	200	400	50	5	3	4.4	5
500 (508.8)	420 (434.4)	600	660	500	50	200	400	100	6	3	5	5.6

*Indicates a value when two inner blocks are in close contact with each other.

KR30H Without Cover, Direct Motor Coupling

Model KR30H□□C (with a Single Short Nut Block)

Model KR30H□□D (with Two Short Nut Blocks)

For model number coding, see **A2-136**.

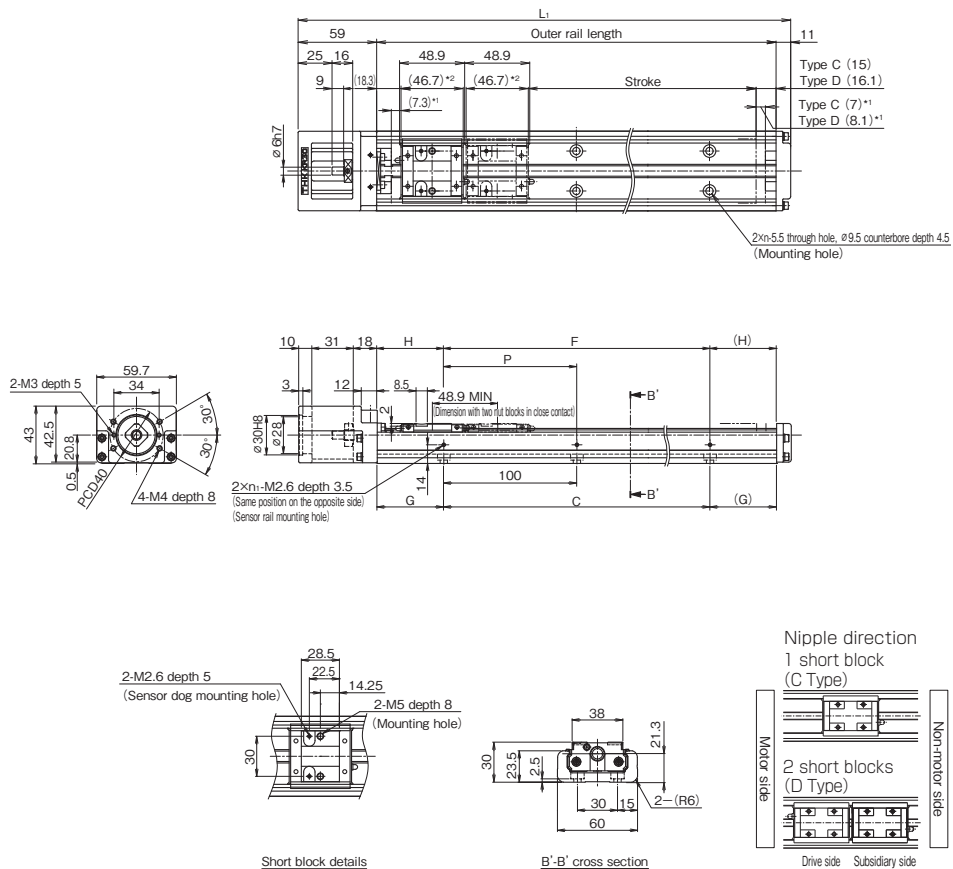

*1 Distance between the mechanical stopper and the stroke starting position.

*2 This indicates the short block length when calculating the possible stroke range.
It is 95.6 mm (total) for a KR30H with 2 short blocks in close contact with each other (D type).

Stroke (mm) (stroke between mechanical stoppers)		Outer rail length (mm)	Overall length L ₁ (mm)	C (mm)	G (mm)	P (mm)	F (mm)	H (mm)	n	n ₁	Overall main unit mass (kg)	
Type C	Type D*										Type C	Type D
70 (84.3)	20 (35.4)	150	220	100	25	100	100	25	2	2	1.4	1.6
120 (134.3)	70 (85.4)	200	270	100	50	100	100	50	2	2	1.7	1.9
220 (234.3)	170 (185.4)	300	370	200	50	200	200	50	3	2	2.3	2.5
320 (334.3)	270 (285.4)	400	470	300	50	200	200	100	4	2	2.8	3
420 (434.3)	370 (385.4)	500	570	400	50	200	400	50	5	3	3.4	3.6
520 (534.3)	470 (485.4)	600	670	500	50	200	400	100	6	3	4	4.2

*Indicates a value when two inner blocks are in close contact with each other.

KR30H With Cover, Direct Motor Coupling

Model KR30H□□C (with a Single Short Nut Block)

Model KR30H□□D (with Two Short Nut Blocks)

For model number coding, see **A2-136**.

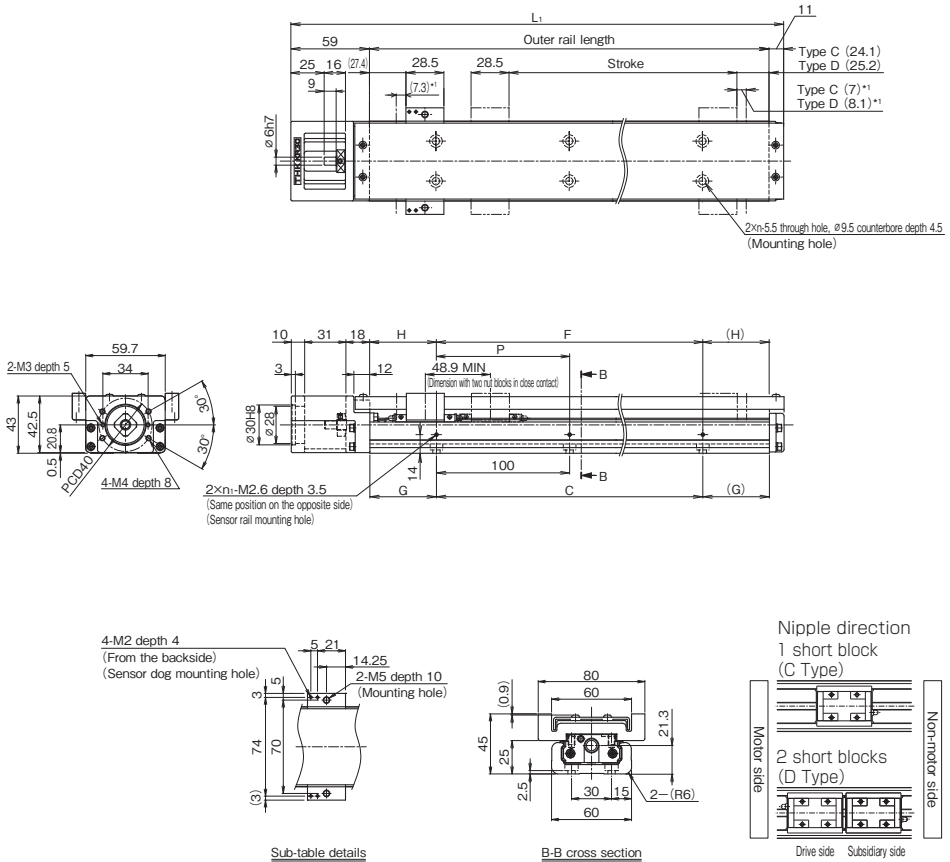

*1 Distance between the mechanical stopper and the stroke starting position.

Stroke (mm) (stroke between mechanical stoppers)		Outer rail length (mm)	Overall length L ₁ (mm)	C (mm)	G (mm)	P (mm)	F (mm)	H (mm)	n	n ₁	Overall main unit mass (kg)	
Type C	Type D*										Type C	Type D
70 (84.3)	20 (35.4)	150	220	100	25	100	100	25	2	2	1.6	1.9
120 (134.3)	70 (85.4)	200	270	100	50	100	100	50	2	2	1.9	2.2
220 (234.3)	170 (185.4)	300	370	200	50	200	200	50	3	2	2.5	2.8
320 (334.3)	270 (285.4)	400	470	300	50	200	200	100	4	2	3.1	3.4
420 (434.3)	370 (385.4)	500	570	400	50	200	400	50	5	3	3.7	4
520 (534.3)	470 (485.4)	600	670	500	50	200	400	100	6	3	4.3	4.6

*Indicates a value when two inner blocks are in close contact with each other.

KR30H Without Cover, Motor Wrap

Model KR30H□□C (with a Single Short Nut Block)

Model KR30H□□D (with Two Short Nut Blocks)

For model number coding, see **A2-136**.

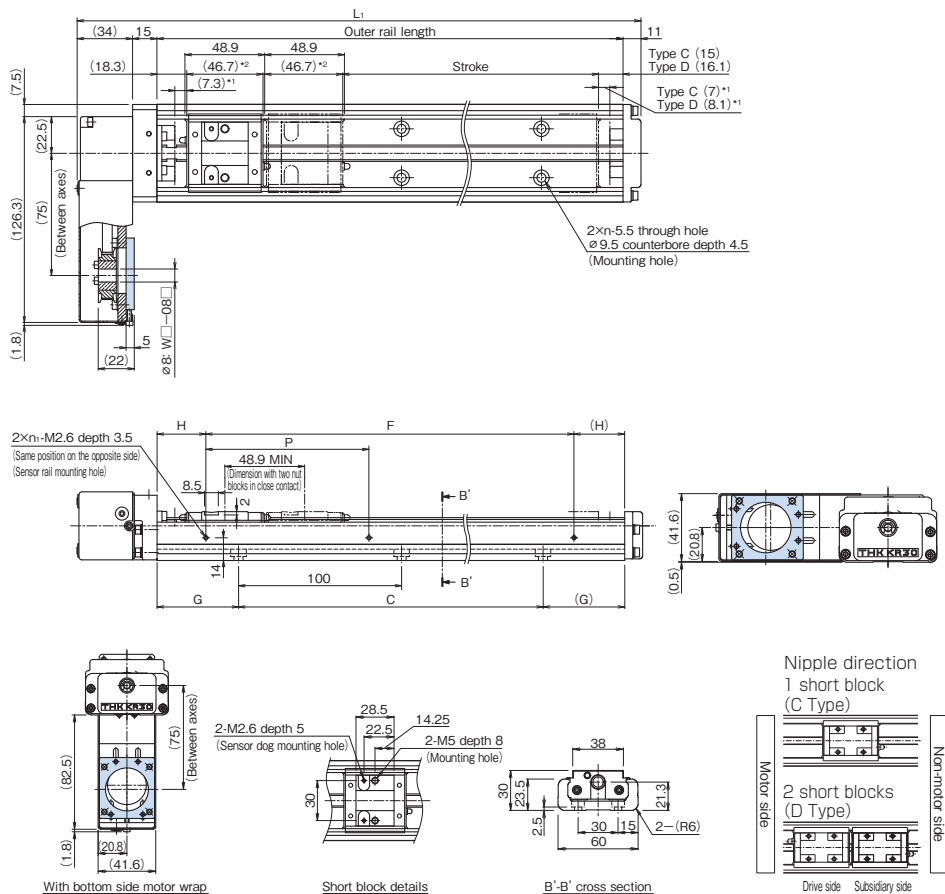

*1 Distance between the mechanical stopper and the stroke starting position.

*2 This indicates the short block length when calculating the possible stroke range.
It is 95.6 mm (total) for a KR30H with 2 short blocks in close contact with each other (D type).

Stroke (mm) (stroke between mechanical stoppers)		Outer rail length (mm)	Overall length L_1 (mm)	C (mm)	G (mm)	P (mm)	F (mm)	H (mm)	n	n_1	Overall main unit mass (kg)	
Type C	Type D*										Type C	Type D
70 (84.3)	20 (35.4)	150	210	100	25	100	100	25	2	2	1.7	1.9
120 (134.3)	70 (85.4)	200	260	100	50	100	100	50	2	2	2	2.2
220 (234.3)	170 (185.4)	300	360	200	50	200	200	50	3	2	2.6	2.8
320 (334.3)	270 (285.4)	400	460	300	50	200	200	100	4	2	3.2	3.4
420 (434.3)	370 (385.4)	500	560	400	50	200	400	50	5	3	3.7	3.9
520 (534.3)	470 (485.4)	600	660	500	50	200	400	100	6	3	4.3	4.5

*Indicates a value when two inner blocks are in close contact with each other.

KR30H With Cover, Motor Wrap

Model KR30H□□C (with a Single Short Nut Block)

Model KR30H□□D (with Two Short Nut Blocks)

For model number coding, see **A2-136**.

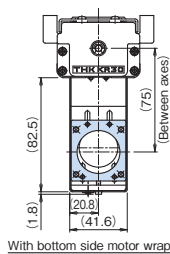
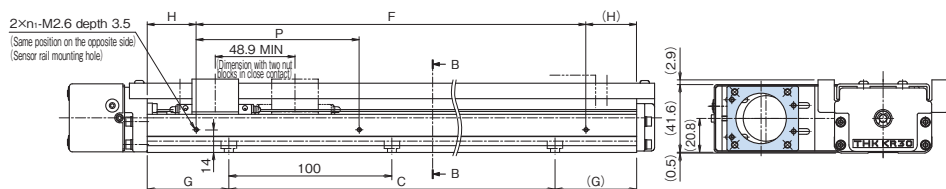
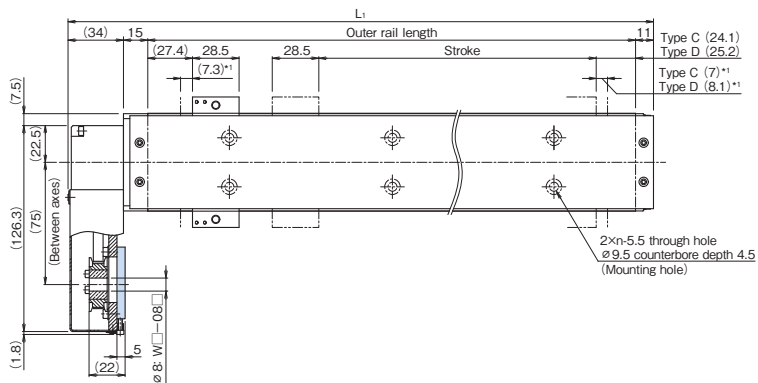

With bottom side motor wrap

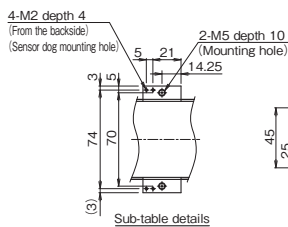

Sub-table details

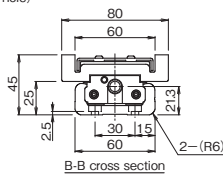

B-B cross section

Nipple direction
1 short block
(C Type)

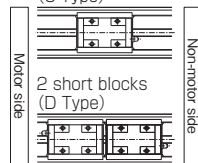

2 short blocks
(D Type)

Drive side Subsidiary side

*1 Distance between the mechanical stopper and the stroke starting position.

Stroke (mm) (stroke between mechanical stoppers)		Outer rail length (mm)	Overall length L ₁ (mm)	C (mm)	G (mm)	P (mm)	F (mm)	H (mm)	n	n ₁	Overall main unit mass (kg)	
Type C	Type D*										Type C	Type D
70 (84.3)	20 (35.4)	150	210	100	25	100	100	25	2	2	1.9	2.2
120 (134.3)	70 (85.4)	200	260	100	50	100	100	50	2	2	2.2	2.5
220 (234.3)	170 (185.4)	300	360	200	50	200	200	50	3	2	2.8	3.1
320 (334.3)	270 (285.4)	400	460	300	50	200	200	100	4	2	3.4	3.7
420 (434.3)	370 (385.4)	500	560	400	50	200	400	50	5	3	4.1	4.4
520 (534.3)	470 (485.4)	600	660	500	50	200	400	100	6	3	4.7	5

*Indicates a value when two inner blocks are in close contact with each other.

KR33 Without Cover, Direct Motor Coupling

Model KR33□□A (with a Single Long Nut Block)

Model KR33□□B (with Two Long Nut Blocks)

For model number coding, see **A2-136**.

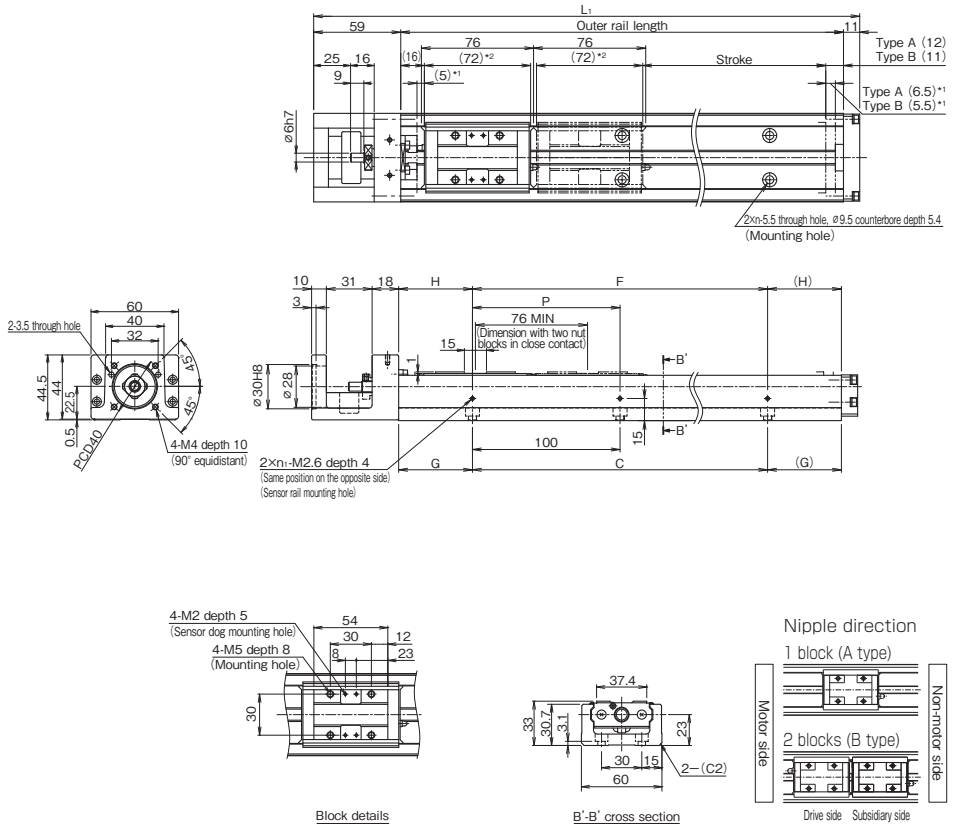

*1 Distance between the mechanical stopper and the stroke starting position.

*2 This indicates the block length when calculating the possible stroke range.

It is 148 mm (total) for a KR33 with 2 blocks in close contact with each other (B type, without QZ).

Stroke (mm) (stroke between mechanical stoppers)		Outer rail length (mm)	Overall length L ₁ (mm)	C (mm)	G (mm)	P (mm)	F (mm)	H (mm)	n	n ₁	Overall main unit mass (kg)	
Type A	Type B										Type A	Type B
50 (61.5)	—	150	220	100	25	100	100	25	2	2	1.9	—
100 (111.5)	—	200	270	100	50	100	100	50	2	2	2.2	—
200 (211.5)	125 (135.5)	300	370	200	50	200	200	50	3	2	3	3.4
300 (311.5)	225 (235.5)	400	470	300	50	200	200	100	4	2	3.7	4.1
400 (411.5)	325 (335.5)	500	570	400	50	200	400	50	5	3	4.4	4.8
500 (511.5)	425 (435.5)	600	670	500	50	200	400	100	6	3	5.2	5.6
600 (611.5)	525 (535.5)	700	770	600	50	200	600	50	7	4	5.9	6.3

*Indicates a value when two inner blocks are in close contact with each other.

KR33 With Cover, Direct Motor Coupling

Model KR33□□A (with a Single Long Nut Block)

Model KR33□□B (with Two Long Nut Blocks)

For model number coding, see **A2-136**.

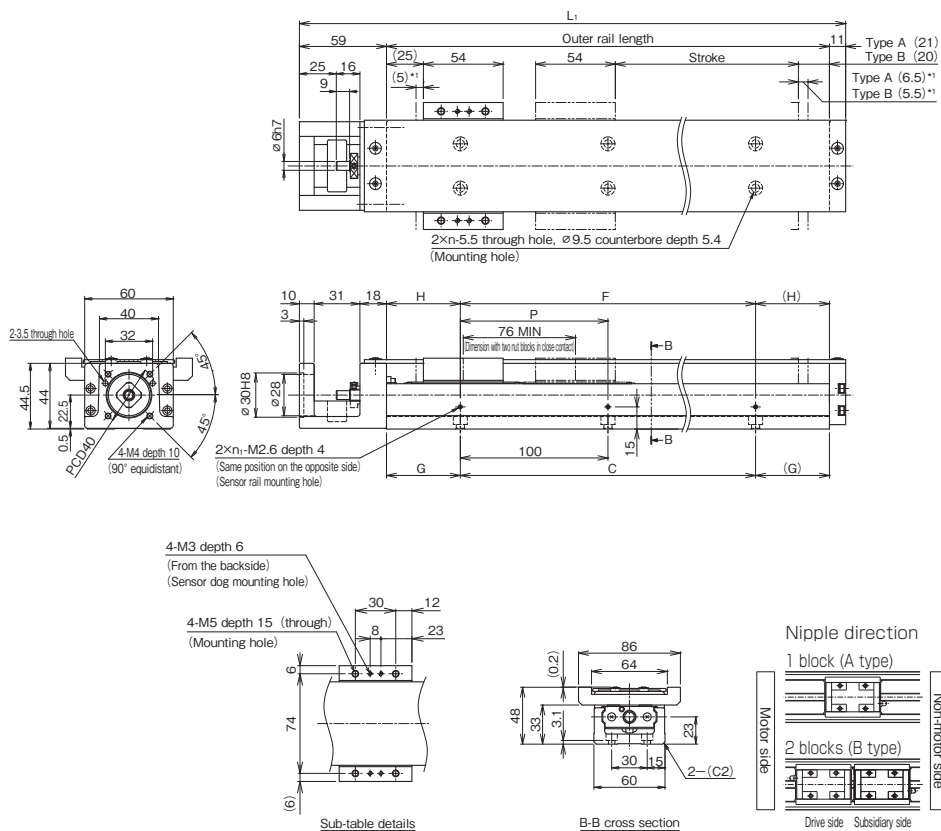

*1 Distance between the mechanical stopper and the stroke starting position.

Stroke (mm) (stroke between mechanical stoppers)		Outer rail length (mm)	Overall length L_1 (mm)	C (mm)	G (mm)	P (mm)	F (mm)	H (mm)	n	n_1	Overall main unit mass (kg)	
Type A	Type B ¹										Type A	Type B
50 (61.5)	—	150	220	100	25	100	100	25	2	2	2.2	—
100 (111.5)	—	200	270	100	50	100	100	50	2	2	2.6	—
200 (211.5)	125 (135.5)	300	370	200	50	200	200	50	3	2	3.3	3.9
300 (311.5)	225 (235.5)	400	470	300	50	200	200	100	4	2	4.1	4.7
400 (411.5)	325 (335.5)	500	570	400	50	200	400	50	5	3	4.9	5.5
500 (511.5)	425 (435.5)	600	670	500	50	200	400	100	6	3	5.6	6.2
600 (611.5)	525 (535.5)	700	770	600	50	200	600	50	7	4	6.4	7

¹Indicates a value when two inner blocks are in close contact with each other.

Note) It must be noted that the cover-mounting bolt is 0.2 mm higher than the top face of the top table.

KR33 Without Cover, Motor Wrap

Model KR33□□A (with a Single Long Nut Block)

Model KR33□□B (with Two Long Nut Blocks)

For model number coding, see **A2-136**.

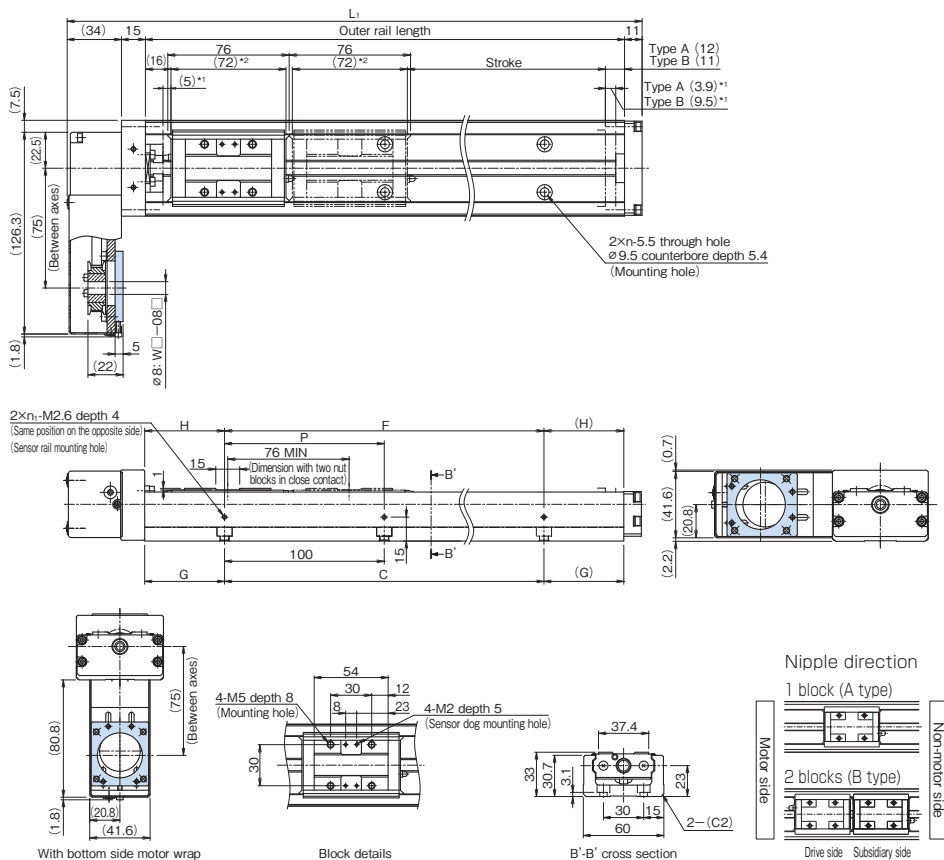

^{*1} Distance between the mechanical stopper and the stroke starting position.

^{*2} This indicates the block length when calculating the possible stroke range.

It is 148 mm (total) for a KR33 with 2 blocks in close contact with each other (B type, without QZ).

Stroke (mm) (stroke between mechanical stoppers)		Outer rail length (mm)	Overall length L_1 (mm)	C (mm)	G (mm)	P (mm)	F (mm)	H (mm)	n	n_1	Overall main unit mass (kg)	
Type A	Type B [*]										Type A	Type B
50 (61.5)	—	150	210	100	25	100	100	25	2	2	2.2	—
100 (111.5)	—	200	260	100	50	100	100	50	2	2	2.6	—
200 (211.5)	125 (135.5)	300	360	200	50	200	200	50	3	2	3.3	3.7
300 (311.5)	225 (235.5)	400	460	300	50	200	200	100	4	2	4	4.4
400 (411.5)	325 (335.5)	500	560	400	50	200	400	50	5	3	4.7	5.1
500 (511.5)	425 (435.5)	600	660	500	50	200	400	100	6	3	5.5	5.9
600 (611.5)	525 (535.5)	700	760	600	50	200	600	50	7	4	6.2	6.6

^{*}Indicates a value when two inner blocks are in close contact with each other.

KR33 With Cover, Motor Wrap

Model KR33□□A (with a Single Long Nut Block)

Model KR33□□B (with Two Long Nut Blocks)

For model number coding, see **A2-136**.

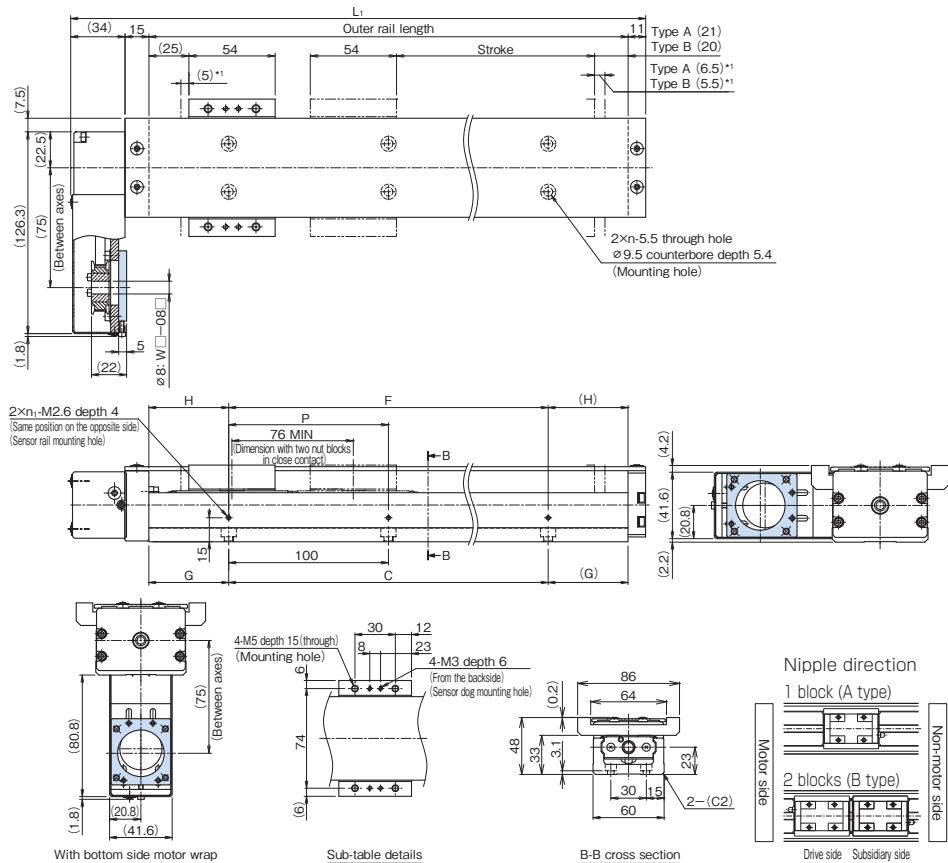

*1 Distance between the mechanical stopper and the stroke starting position.

Stroke (mm) (stroke between mechanical stoppers)		Outer rail length (mm)	Overall length L_1 (mm)	C (mm)	G (mm)	P (mm)	F (mm)	H (mm)	n	n_1	Overall main unit mass (kg)	
Type A	Type B*										Type A	Type B
50 (61.5)	—	150	210	100	25	100	100	25	2	2	2.5	—
100 (111.5)	—	200	260	100	50	100	100	50	2	2	2.9	—
200 (211.5)	125 (135.5)	300	360	200	50	200	200	50	3	2	3.6	4.2
300 (311.5)	225 (235.5)	400	460	300	50	200	200	100	4	2	4.4	5
400 (411.5)	325 (335.5)	500	560	400	50	200	400	50	5	3	5.2	5.8
500 (511.5)	425 (435.5)	600	660	500	50	200	400	100	6	3	5.9	6.5
600 (611.5)	525 (535.5)	700	760	600	50	200	600	50	7	4	6.7	7.3

*Indicates a value when two inner blocks are in close contact with each other.

Note) It must be noted that the cover-mounting bolt is 0.2 mm higher than the top face of the top table.

KR33 Without Cover, Direct Motor Coupling

Model KR33□□C (with a Single Short Nut Block)

Model KR33□□D (with Two Short Nut Blocks)

For model number coding, see **A2-136**.

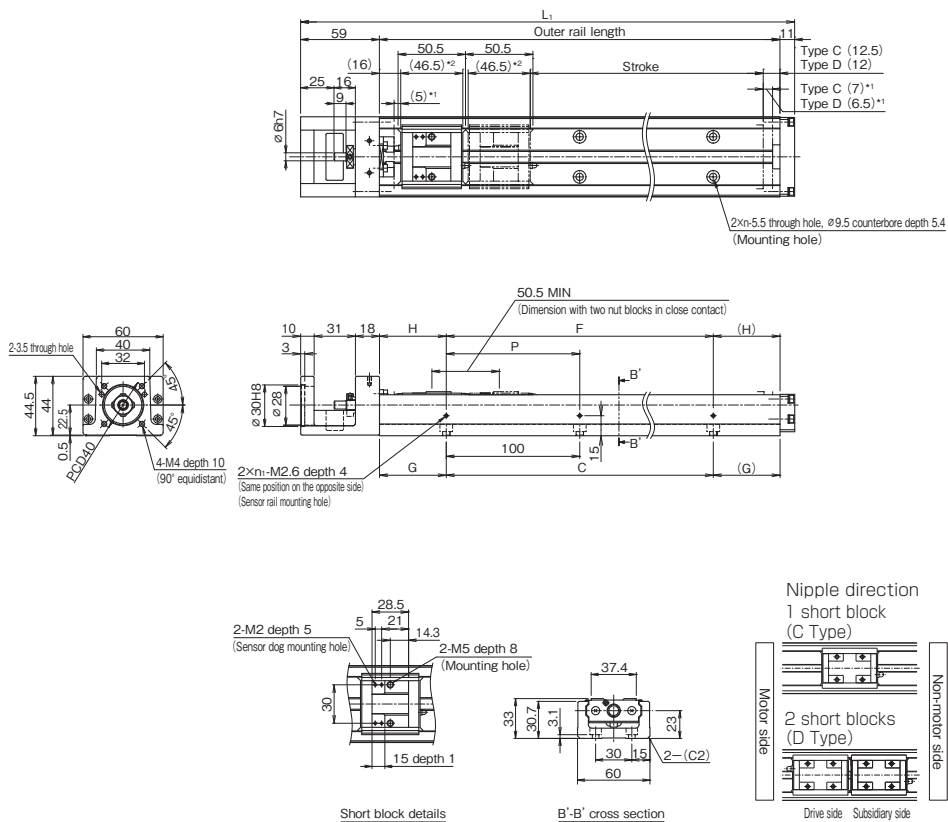

*1 Distance between the mechanical stopper and the stroke starting position.

*2 This indicates the short block length when calculating the possible stroke range.

It is 97.2 mm (total) for a KR33 with 2 short blocks in close contact with each other (D type, without QZ).

Stroke (mm) (stroke between mechanical stoppers)		Outer rail length (mm)	Overall length L_1 (mm)	C (mm)	G (mm)	P (mm)	F (mm)	H (mm)	n	n_1	Overall main unit mass (kg)	
Type C	Type D										Type C	Type D
75 (87)	25 (36.5)	150	220	100	25	100	100	25	2	2	1.7	1.9
125 (137)	75 (86.5)	200	270	100	50	100	100	50	2	2	2	2.2
225 (237)	175 (186.5)	300	370	200	50	200	200	50	3	2	2.8	3
325 (337)	275 (286.5)	400	470	300	50	200	200	100	4	2	3.5	3.7
425 (437)	375 (386.5)	500	570	400	50	200	400	50	5	3	4.2	4.4
525 (537)	475 (486.5)	600	670	500	50	200	400	100	6	3	5	5.2
625 (637)	575 (586.5)	700	770	600	50	200	600	50	7	4	5.7	5.9

*Indicates a value when two inner blocks are in close contact with each other.

KR33 With Cover, Direct Motor Coupling

Model KR33□□C (with a Single Short Nut Block)

Model KR33□□D (with Two Short Nut Blocks)

For model number coding, see **A2-136**.

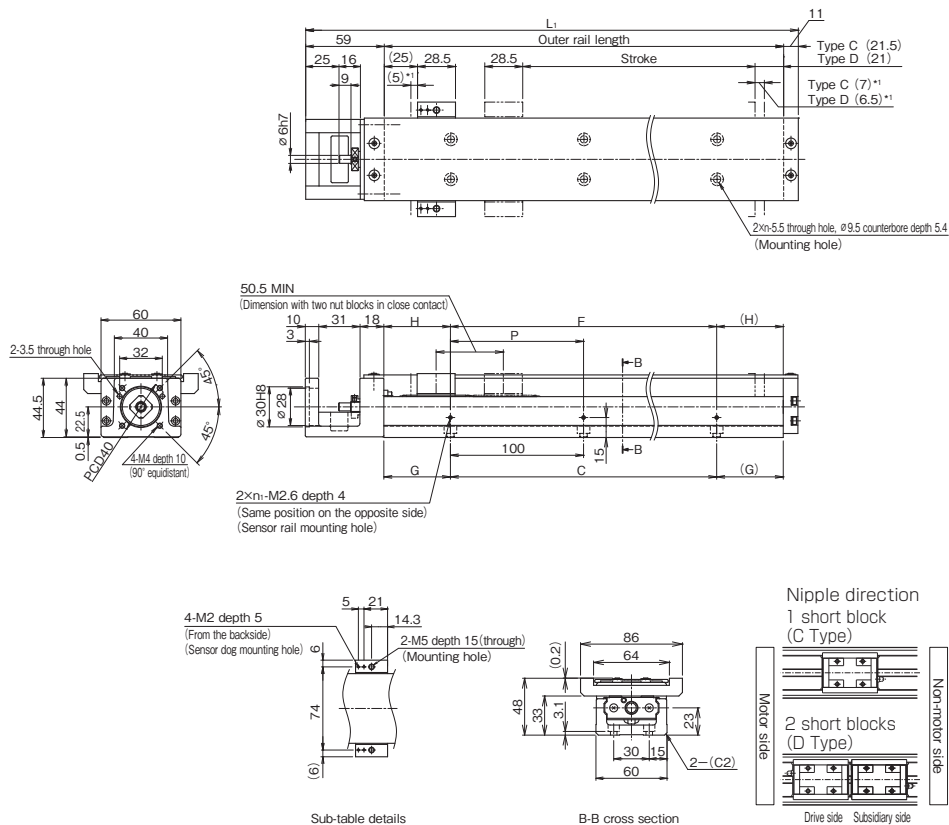

*1 Distance between the mechanical stopper and the stroke starting position.

Stroke (mm) (stroke between mechanical stoppers)		Outer rail length (mm)	Overall length L ₁ (mm)	C (mm)	G (mm)	P (mm)	F (mm)	H (mm)	n	n ₁	Overall main unit mass (kg)	
Type C	Type D										Type C	Type D
75 (87)	25 (36.5)	150	220	100	25	100	100	25	2	2	1.9	2.2
125 (137)	75 (86.5)	200	270	100	50	100	100	50	2	2	2.3	2.6
225 (237)	175 (186.5)	300	370	200	50	200	200	50	3	2	3	3.3
325 (337)	275 (286.5)	400	470	300	50	200	200	100	4	2	3.8	4.1
425 (437)	375 (386.5)	500	570	400	50	200	400	50	5	3	4.6	4.9
525 (537)	475 (486.5)	600	670	500	50	200	400	100	6	3	5.3	5.6
625 (637)	575 (586.5)	700	770	600	50	200	600	50	7	4	6.1	6.4

*Indicates a value when two inner blocks are in close contact with each other.

Note) It must be noted that the cover-mounting bolt is 0.2 mm higher than the top face of the top table.

KR33 Without Cover, Motor Wrap

Model KR33□□C (with a Single Short Nut Block)

Model KR33□□D (with Two Short Nut Blocks)

For model number coding, see **A2-136**.

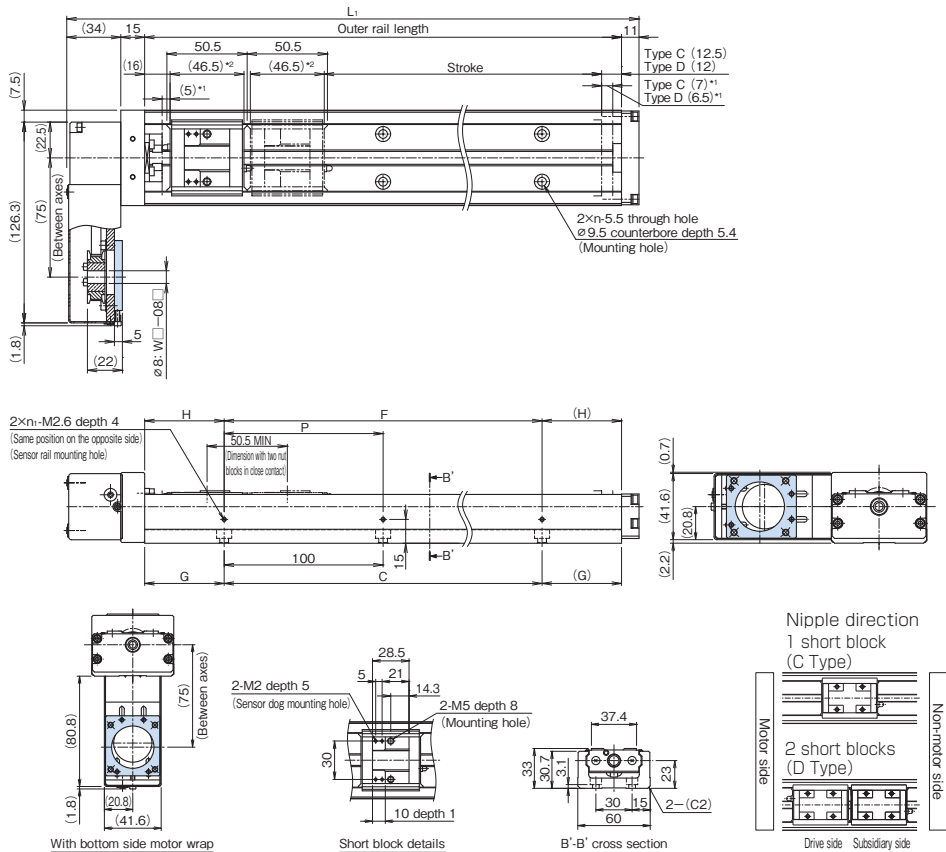

*1 Distance between the mechanical stopper and the stroke starting position.

*2 This indicates the short block length when calculating the possible stroke range.

It is 97.2 mm (total) for a KR33 with 2 short blocks in close contact with each other (D type, without QZ).

Stroke (mm) (stroke between mechanical stoppers)		Outer rail length (mm)	Overall length L ₁ (mm)	C (mm)	G (mm)	P (mm)	F (mm)	H (mm)	n	n ₁	Overall main unit mass (kg)	
Type C	Type D										Type C	Type D
75 (87)	25 (36.5)	150	210	100	25	100	100	25	2	2	2	2.2
125 (137)	75 (86.5)	200	260	100	50	100	100	50	2	2	2.4	2.6
225 (237)	175 (186.5)	300	360	200	50	200	200	50	3	2	3.1	3.3
325 (337)	275 (286.5)	400	460	300	50	200	200	100	4	2	3.8	4
425 (437)	375 (386.5)	500	560	400	50	200	400	50	5	3	4.5	4.7
525 (537)	475 (486.5)	600	660	500	50	200	400	100	6	3	5.3	5.5
625 (637)	575 (586.5)	700	760	600	50	200	600	50	7	4	6	6.2

*Indicates a value when two inner blocks are in close contact with each other.

KR33 With Cover, Motor Wrap

Model KR33□□C (with a Single Short Nut Block)

Model KR33□□D (with Two Short Nut Blocks)

For model number coding, see **A2-136**.

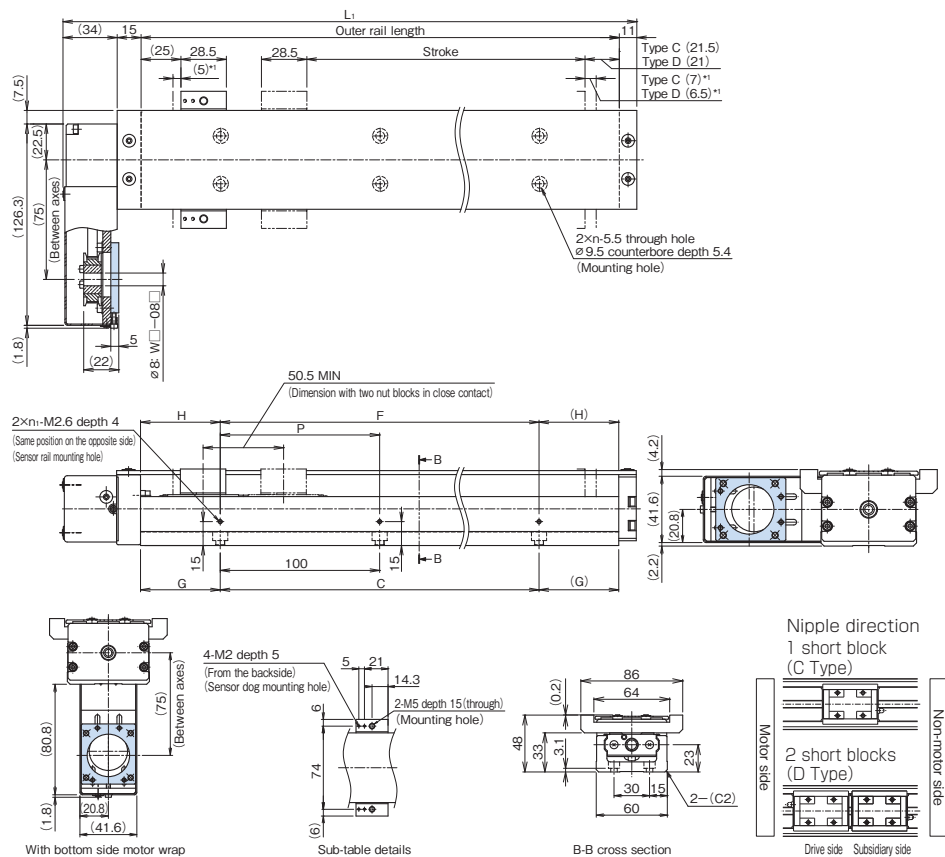

*1 Distance between the mechanical stopper and the stroke starting position.

Stroke (mm) (stroke between mechanical stoppers)		Outer rail length (mm)	Overall length L_1 (mm)	C (mm)	G (mm)	P (mm)	F (mm)	H (mm)	n	n_1	Overall main unit mass (kg)	
Type C	Type D*										Type C	Type D
75 (87)	25 (36.5)	150	210	100	25	100	100	25	2	2	2.2	2.5
125 (137)	75 (86.5)	200	260	100	50	100	100	50	2	2	2.6	2.9
225 (237)	175 (186.5)	300	360	200	50	200	200	50	3	2	3.3	3.6
325 (337)	275 (286.5)	400	460	300	50	200	200	100	4	2	4.1	4.4
425 (437)	375 (386.5)	500	560	400	50	200	400	50	5	3	4.9	5.2
525 (537)	475 (486.5)	600	660	500	50	200	400	100	6	3	5.6	5.9
625 (637)	575 (586.5)	700	760	600	50	200	600	50	7	4	6.4	6.7

*Indicates a value when two inner blocks are in close contact with each other.

Note) It must be noted that the cover-mounting bolt is 0.2 mm higher than the top face of the top table.

KR45H Without Cover, Direct Motor Coupling

Model KR45H□□A (with a Single Long Nut Block)

Model KR45H□□B (with Two Long Nut Blocks)

For model number coding, see **A2-136**.

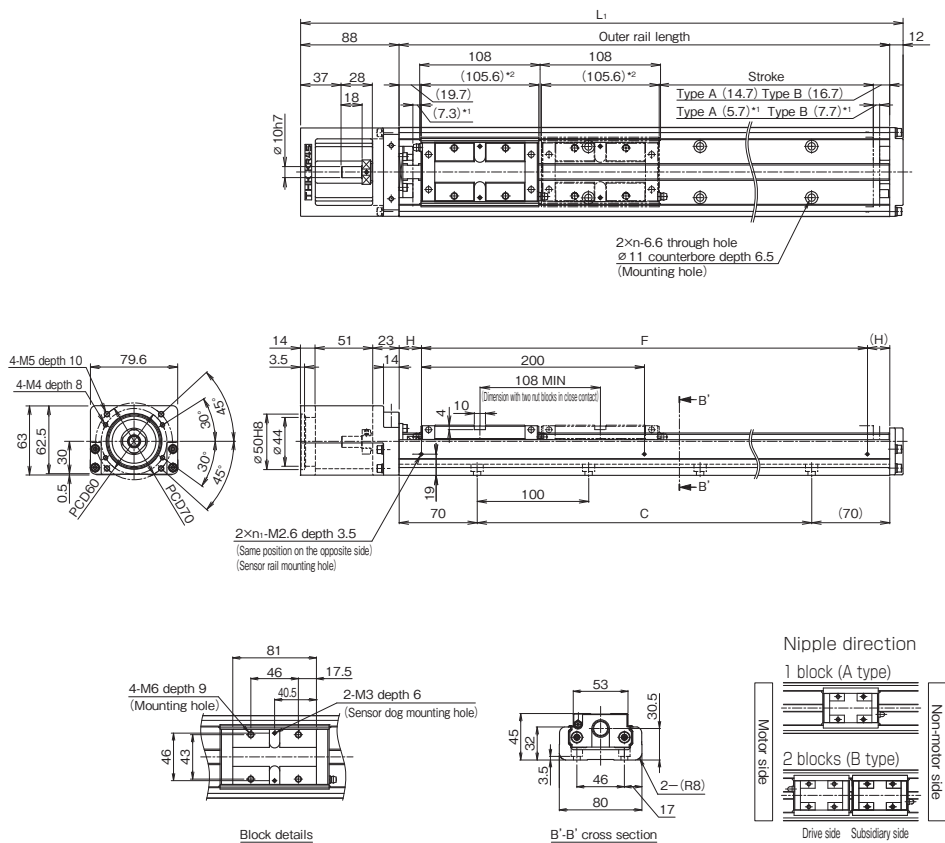

*1 Distance between the mechanical stopper and the stroke starting position.

*2 This indicates the block length when calculating the possible stroke range.

It is 213.6 mm (total) for a KR45H with 2 blocks in close contact with each other (B type).

Stroke (mm) (stroke between mechanical stoppers)		Outer rail length (mm)	Overall length L_1 (mm)	C (mm)	F (mm)	H (mm)	n	n_1	Overall main unit mass (kg)	
Type A	Type B								Type A	Type B
200 (213)	90 (105)	340	440	200	200	70	3	2	5.4	6.4
300 (313)	190 (205)	440	540	300	400	20	4	3	6.5	7.5
400 (413)	290 (305)	540	640	400	400	70	5	3	7.5	8.5
500 (513)	390 (405)	640	740	500	600	20	6	4	8.6	9.6
600 (613)	490 (505)	740	840	600	600	70	7	4	9.7	10.7
700 (713)	590 (605)	840	940	700	800	20	8	5	10.7	11.7
800 (813)	690 (705)	940	1040	800	800	70	9	5	11.8	12.8

*Indicates a value when two inner blocks are in close contact with each other.

KR45H With Cover, Direct Motor Coupling

Model KR45H□□□A (with a Single Long Nut Block)

Model KR45H□□□B (with Two Long Nut Blocks)

For model number coding, see **A2-136**.

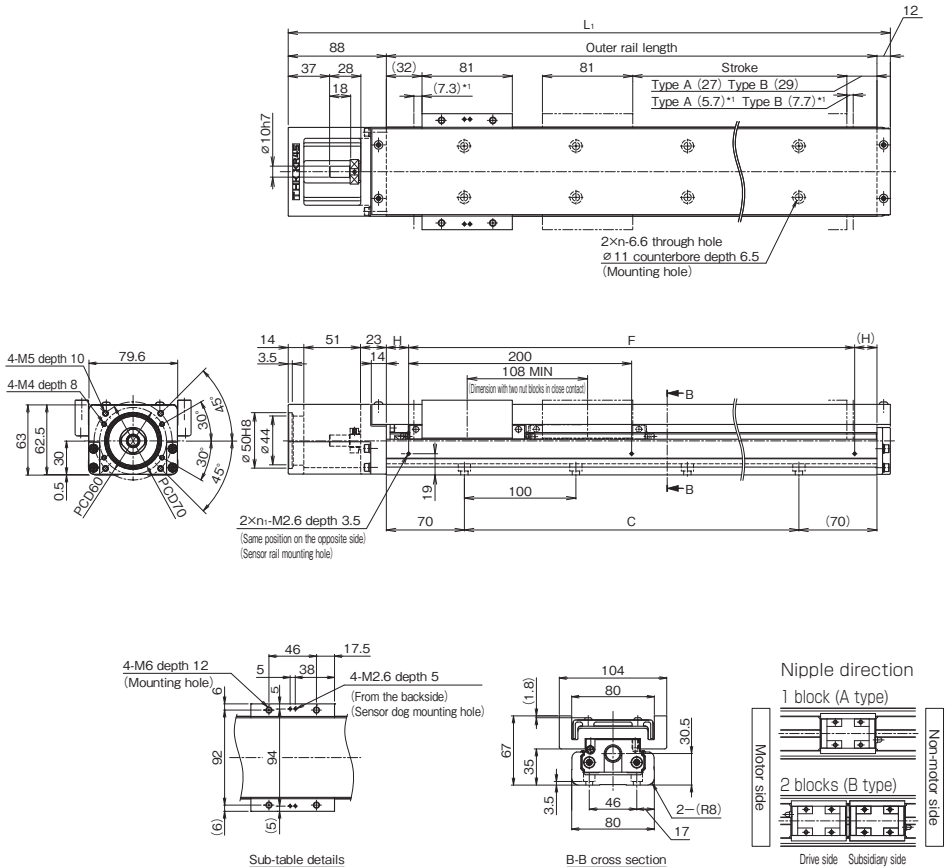

*1 Distance between the mechanical stopper and the stroke starting position.

Stroke (mm) (stroke between mechanical stoppers)		Outer rail length (mm)	Overall length L_1 (mm)	C (mm)	F (mm)	H (mm)	n	n_1	Overall main unit mass (kg)	
Type A	Type B'								Type A	Type B
200 (213)	90 (105)	340	440	200	200	70	3	2	6.4	7.8
300 (313)	190 (205)	440	540	300	400	20	4	3	7.6	9
400 (413)	290 (305)	540	640	400	400	70	5	3	8.7	10.1
500 (513)	390 (405)	640	740	500	600	20	6	4	9.9	11.3
600 (613)	490 (505)	740	840	600	600	70	7	4	11	12.4
700 (713)	590 (605)	840	940	700	800	20	8	5	12.2	13.6
800 (813)	690 (705)	940	1040	800	800	70	9	5	13.3	14.7

*Indicates a value when two inner blocks are in close contact with each other.

KR45H Without Cover, Motor Wrap

Model KR45H□□A (with a Single Long Nut Block)

Model KR45H□□B (with Two Long Nut Blocks)

For model number coding, see **A2-136**.

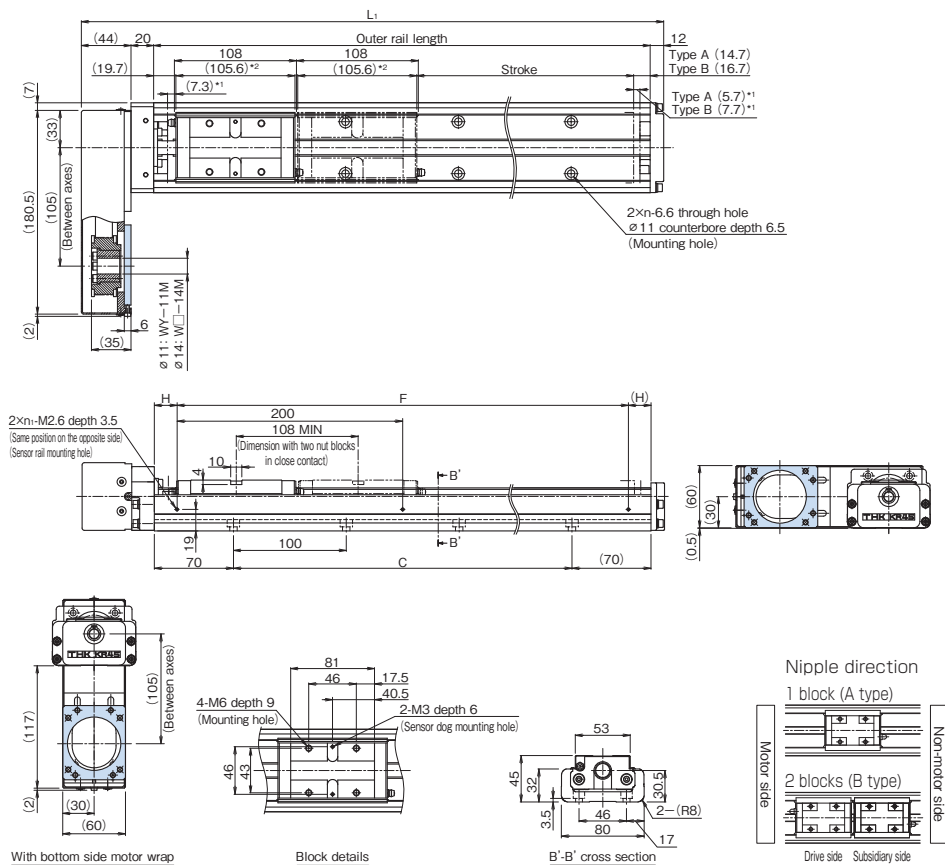

*1 Distance between the mechanical stopper and the stroke starting position.

*2 This indicates the block length when calculating the possible stroke range.

It is 213.6 mm (total) for a KR45H with 2 blocks in close contact with each other (B type).

Stroke (mm) (stroke between mechanical stoppers)		Outer rail length (mm)	Overall length L ₁ (mm)	C (mm)	F (mm)	H (mm)	n	n ₁	Overall main unit mass (kg)	
Type A	Type B*								Type A	Type B
200 (213)	90 (105)	340	416	200	200	70	3	2	6.4	7.4
300 (313)	190 (205)	440	516	300	400	20	4	3	7.4	8.4
400 (413)	290 (305)	540	616	400	400	70	5	3	8.5	9.5
500 (513)	390 (405)	640	716	500	600	20	6	4	9.5	10.5
600 (613)	490 (505)	740	816	600	600	70	7	4	10.6	11.6
700 (713)	590 (605)	840	916	700	800	20	8	5	11.7	12.7
800 (813)	690 (705)	940	1016	800	800	70	9	5	12.7	13.7

*Indicates a value when two inner blocks are in close contact with each other.

KR45H With Cover, Motor Wrap

Model KR45H□□A (with a Single Long Nut Block)

Model KR45H□□B (with Two Long Nut Blocks)

For model number coding, see **A2-136**.

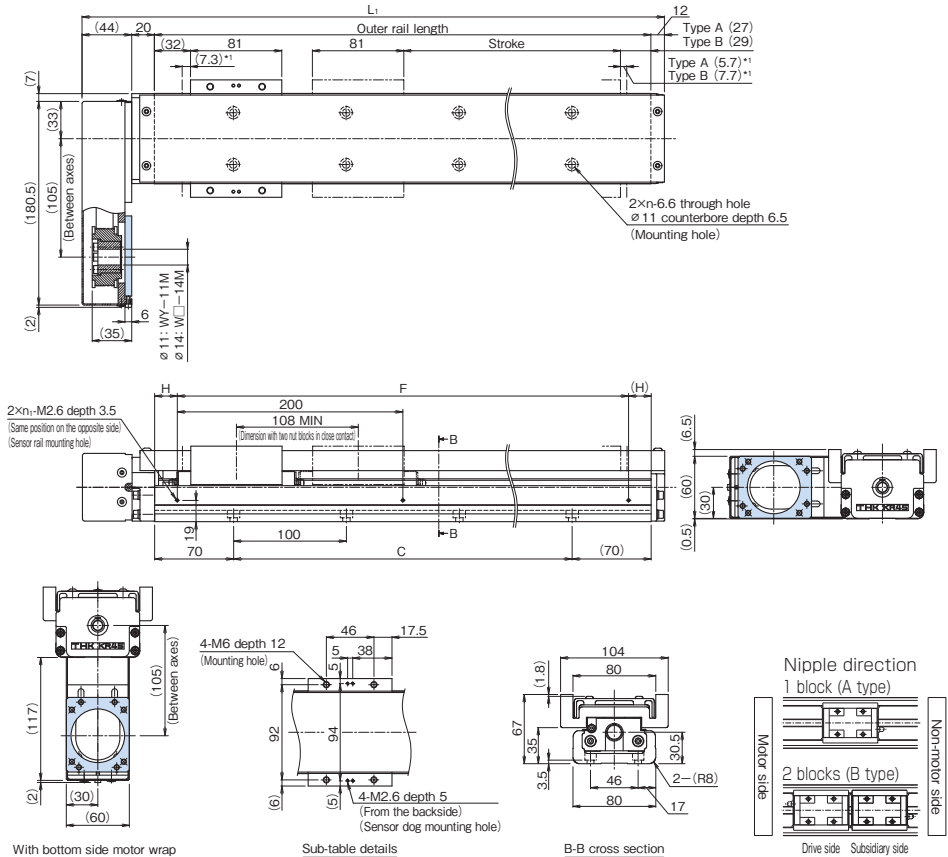

With bottom side motor wrap

Sub-table details

B-B cross section

*1 Distance between the mechanical stopper and the stroke starting position.

Stroke (mm) (stroke between mechanical stoppers)		Outer rail length (mm)	Overall length L ₁ (mm)	C (mm)	F (mm)	H (mm)	n	n ₁	Overall main unit mass (kg)	
Type A	Type B [*]								Type A	Type B
200 (213)	90 (105)	340	416	200	200	70	3	2	7.4	8.8
300 (313)	190 (205)	440	516	300	400	20	4	3	8.5	9.9
400 (413)	290 (305)	540	616	400	400	70	5	3	9.7	11.1
500 (513)	390 (405)	640	716	500	600	20	6	4	10.8	12.2
600 (613)	490 (505)	740	816	600	600	70	7	4	12	13.4
700 (713)	590 (605)	840	916	700	800	20	8	5	13.1	14.5
800 (813)	690 (705)	940	1016	800	800	70	9	5	14.2	15.6

*Indicates a value when two inner blocks are in close contact with each other.

KR45H Without Cover, Direct Motor Coupling

Model KR45H□□C (with a Single Short Nut Block)

Model KR45H□□D (with Two Short Nut Blocks)

For model number coding, see **A2-136**.

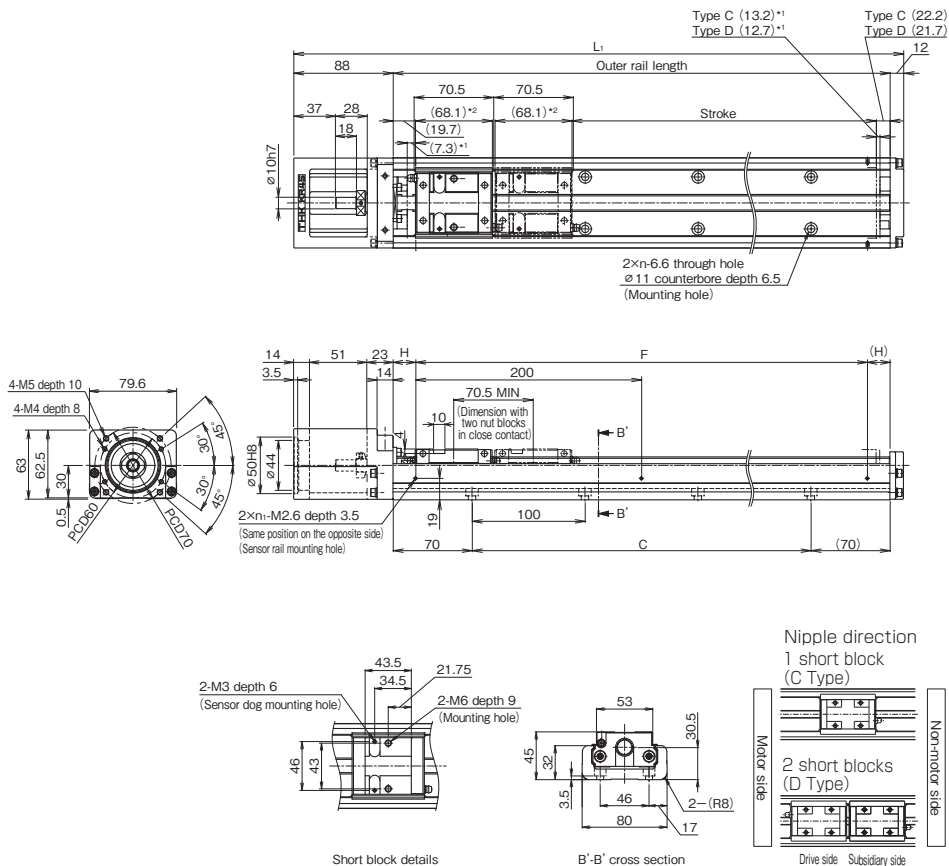

*1 Distance between the mechanical stopper and the stroke starting position.

*2 This indicates the short block length when calculating the possible stroke range.

It is 138.6 mm (total) for a KR45H with 2 short blocks in close contact with each other (D type).

Stroke (mm) (stroke between mechanical stoppers)		Outer rail length (mm)	Overall length L_1 (mm)	C (mm)	F (mm)	H (mm)	n	n_1	Overall main unit mass (kg)	
Type C	Type D								Type C	Type D
230 (250.5)	160 (180)	340	440	200	200	70	3	2	5	5.6
330 (350.5)	260 (280)	440	540	300	400	20	4	3	6.1	6.7
430 (450.5)	360 (380)	540	640	400	400	70	5	3	7.1	7.7
530 (550.5)	460 (480)	640	740	500	600	20	6	4	8.2	8.8
630 (650.5)	560 (580)	740	840	600	600	70	7	4	9.3	9.9
730 (750.5)	660 (680)	840	940	700	800	20	8	5	10.3	10.9
830 (850.5)	760 (780)	940	1040	800	800	70	9	5	11.4	12

*Indicates a value when two inner blocks are in close contact with each other.

KR45H With Cover, Direct Motor Coupling

Model KR45H□□C (with a Single Short Nut Block)

Model KR45H□□D (with Two Short Nut Blocks)

For model number coding, see **A2-136**.

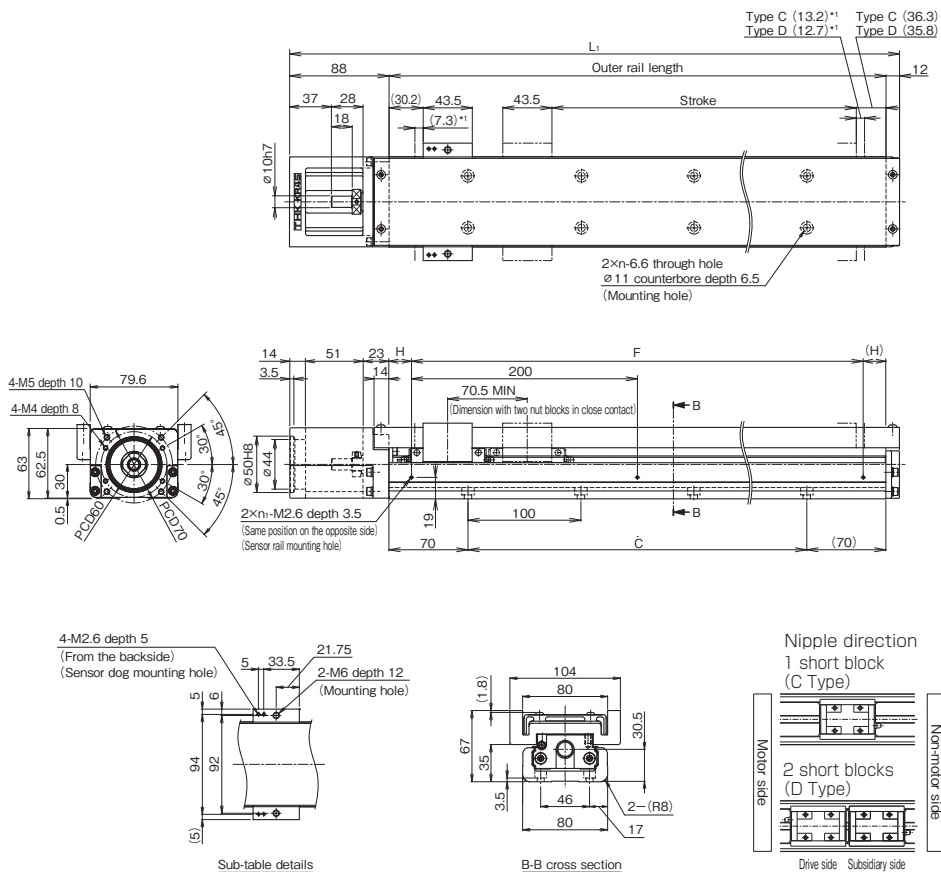

*1 Distance between the mechanical stopper and the stroke starting position.

Stroke (mm) (stroke between mechanical stoppers)		Outer rail length (mm)	Overall length L_1 (mm)	C (mm)	F (mm)	H (mm)	n	n_1	Overall main unit mass (kg)	
Type C	Type D								Type C	Type D
230 (250.5)	160 (180)	340	440	200	200	70	3	2	5.8	6.6
330 (350.5)	260 (280)	440	540	300	400	20	4	3	7	7.8
430 (450.5)	360 (380)	540	640	400	400	70	5	3	8.1	8.9
530 (550.5)	460 (480)	640	740	500	600	20	6	4	9.3	10.1
630 (650.5)	560 (580)	740	840	600	600	70	7	4	10.4	11.2
730 (750.5)	660 (680)	840	940	700	800	20	8	5	11.6	12.4
830 (850.5)	760 (780)	940	1040	800	800	70	9	5	12.7	13.5

*Indicates a value when two inner blocks are in close contact with each other.

KR45H Without Cover, Motor Wrap

Model KR45H□□C (with a Single Short Nut Block)

Model KR45H□□D (with Two Short Nut Blocks)

For model number coding, see **A2-136**.

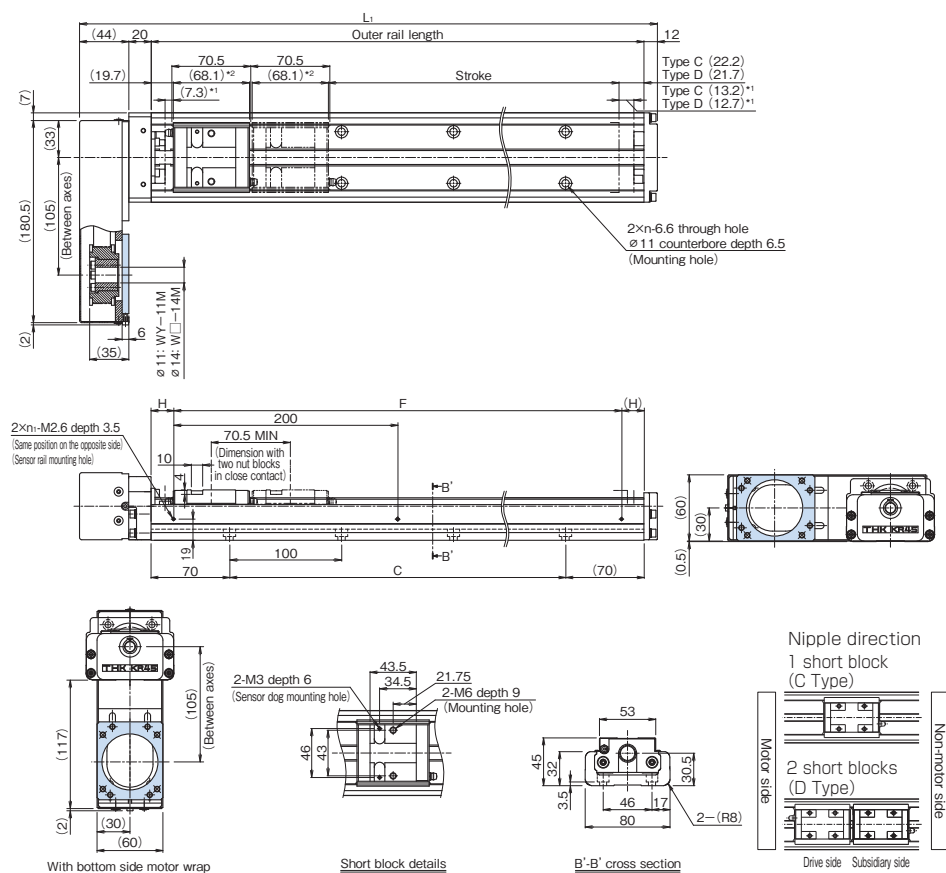

*1 Distance between the mechanical stopper and the stroke starting position.

*2 This indicates the short block length when calculating the possible stroke range.

It is 138.6 mm (total) for a KR45H with 2 short blocks in close contact with each other (D type).

Stroke (mm) (stroke between mechanical stoppers)		Outer rail length (mm)	Overall length L ₁ (mm)	C (mm)	F (mm)	H (mm)	n	n ₁	Overall main unit mass (kg)	
Type C	Type D*								Type C	Type D
230 (250.5)	160 (180)	340	416	200	200	70	3	2	6	6.6
330 (350.5)	260 (280)	440	516	300	400	20	4	3	7	7.6
430 (450.5)	360 (380)	540	616	400	400	70	5	3	8.1	8.7
530 (550.5)	460 (480)	640	716	500	600	20	6	4	9.1	9.7
630 (650.5)	560 (580)	740	816	600	600	70	7	4	10.2	10.8
730 (750.5)	660 (680)	840	916	700	800	20	8	5	11.3	11.9
830 (850.5)	760 (780)	940	1016	800	800	70	9	5	12.3	12.9

*Indicates a value when two inner blocks are in close contact with each other.

KR45H With Cover, Motor Wrap

Model KR45H□□C (with a Single Short Nut Block)

Model KR45H□□D (with Two Short Nut Blocks)

For model number coding, see **A2-136**.

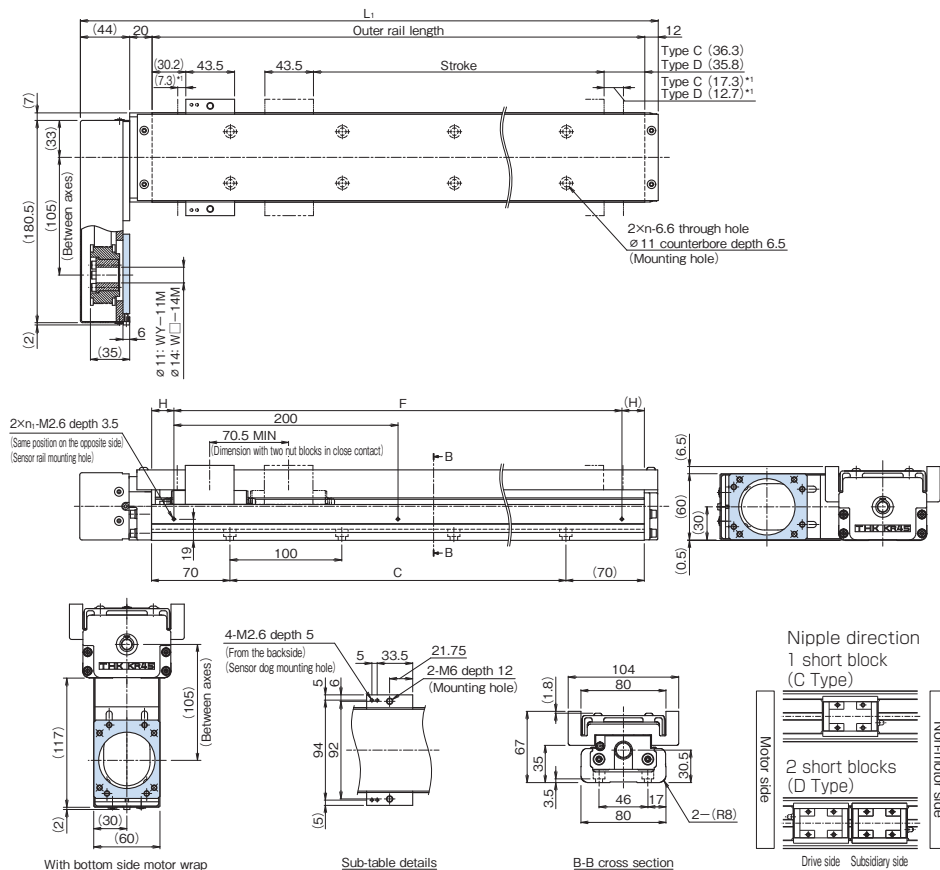

*1 Distance between the mechanical stopper and the stroke starting position.

Stroke (mm) (stroke between mechanical stoppers)		Outer rail length (mm)	Overall length L ₁ (mm)	C (mm)	F (mm)	H (mm)	n	n ₁	Overall main unit mass (kg)	
Type C	Type D [*]								Type C	Type D
230 (250.5)	160 (180)	340	416	200	200	70	3	2	6.8	7.6
330 (350.5)	260 (280)	440	516	300	400	20	4	3	7.9	8.7
430 (450.5)	360 (380)	540	616	400	400	70	5	3	9.1	9.9
530 (550.5)	460 (480)	640	716	500	600	20	6	4	10.2	11
630 (650.5)	560 (580)	740	816	600	600	70	7	4	11.4	12.2
730 (750.5)	660 (680)	840	916	700	800	20	8	5	12.5	13.3
830 (850.5)	760 (780)	940	1016	800	800	70	9	5	13.6	14.4

*Indicates a value when two inner blocks are in close contact with each other.

KR46 Without Cover, Direct Motor Coupling

Model KR46□□A (with a Single Long Nut Block)

Model KR46□□B (with Two Long Nut Blocks)

For model number coding, see **A2-136**.

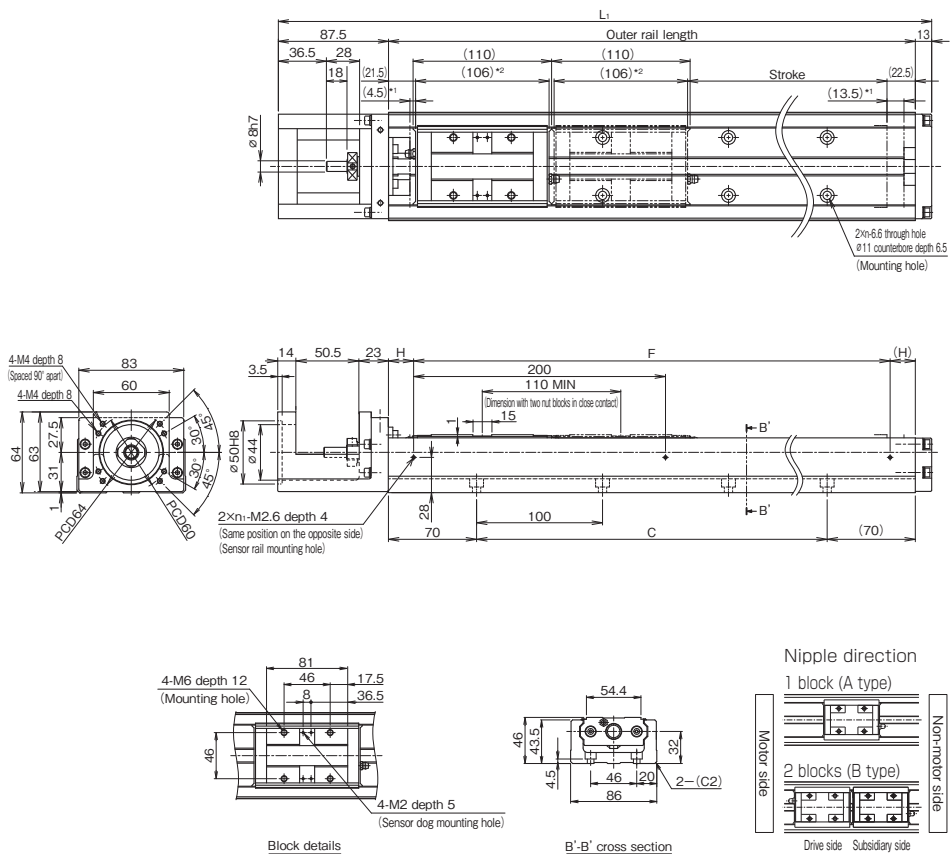

*1 Distance between the mechanical stopper and the stroke starting position.

*2 This indicates the block length when calculating the possible stroke range.

It is 216 mm (total) for a KR46 with 2 blocks in close contact with each other (B type, without QZ).

Stroke (mm) (stroke between mechanical stoppers)		Outer rail length (mm)	Overall length L ₁ (mm)	C (mm)	F (mm)	H (mm)	n	n ₁	Overall main unit mass (kg)	
Type A	Type B*								Type A	Type B
190 (208)	80 (98)	340	440.5	200	200	70	3	2	6.6	7.6
290 (308)	180 (198)	440	540.5	300	400	20	4	3	8	9
390 (408)	280 (298)	540	640.5	400	400	70	5	3	9.4	10.4
490 (508)	380 (398)	640	740.5	500	600	20	6	4	10.8	11.8
590 (608)	480 (498)	740	840.5	600	600	70	7	4	12.2	13.2
690 (708)	580 (598)	840	940.5	700	800	20	8	5	13.6	14.6
790 (808)	680 (698)	940	1040.5	800	800	70	9	5	15	16

*Indicates a value when two inner blocks are in close contact with each other.

KR46 With Cover, Direct Motor Coupling

Model KR46□□A (with a Single Long Nut Block)

Model KR46□□B (with Two Long Nut Blocks)

For model number coding, see **A2-136**.

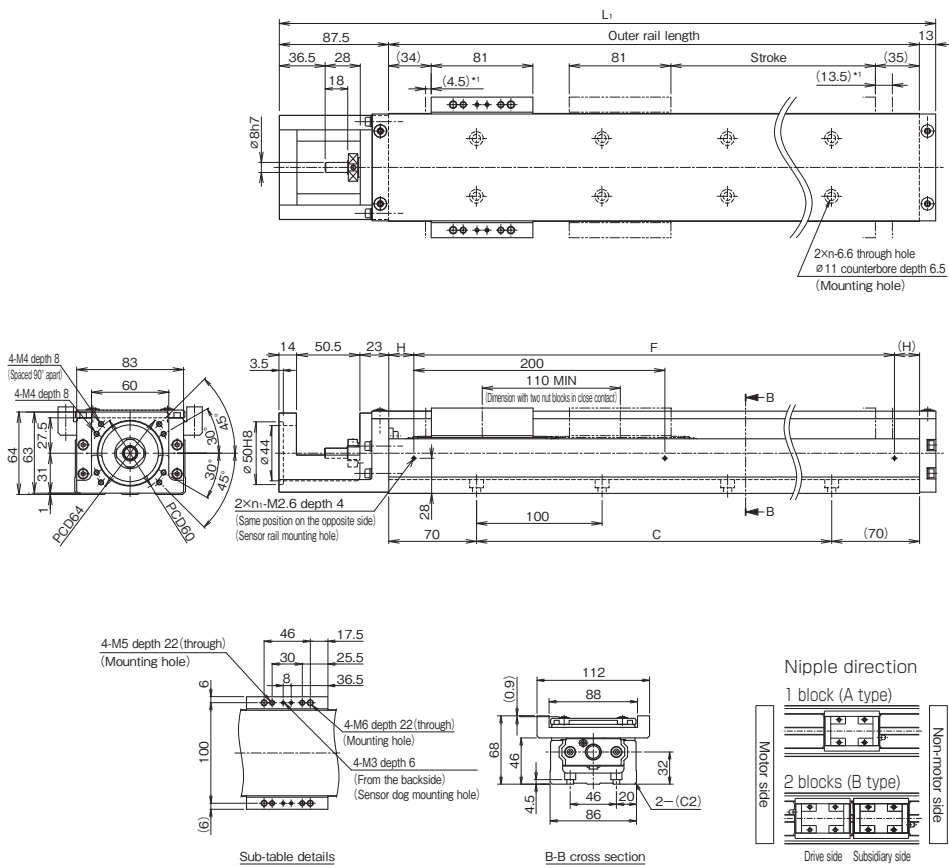

*1 Distance between the mechanical stopper and the stroke starting position.

Stroke (mm) (stroke between mechanical stoppers)		Outer rail length (mm)	Overall length L_1 (mm)	C (mm)	F (mm)	H (mm)	n	n_1	Overall main unit mass (kg)	
Type A	Type B [*]								Type A	Type B
190 (208)	80 (98)	340	440.5	200	200	70	3	2	7.5	8.9
290 (308)	180 (198)	440	540.5	300	400	20	4	3	9	10.4
390 (408)	280 (298)	540	640.5	400	400	70	5	3	10.5	11.9
490 (508)	380 (398)	640	740.5	500	600	20	6	4	12	13.4
590 (608)	480 (498)	740	840.5	600	600	70	7	4	13.5	14.9
690 (708)	580 (598)	840	940.5	700	800	20	8	5	14.9	16.3
790 (808)	680 (698)	940	1040.5	800	800	70	9	5	16.4	17.8

*Indicates a value when two inner blocks are in close contact with each other.

KR46 Without Cover, Motor Wrap

Model KR46□□A (with a Single Long Nut Block)

Model KR46□□B (with Two Long Nut Blocks)

For model number coding, see **A2-136**.

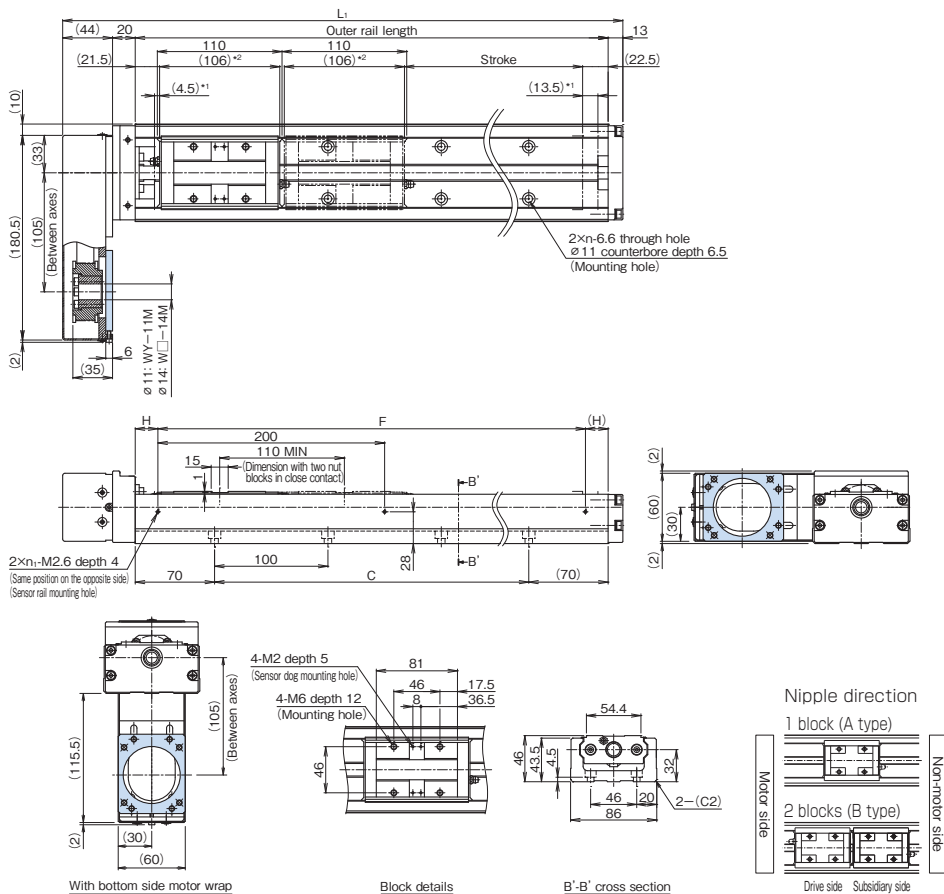

With bottom side motor wrap

Block details

B'-B' cross section

Nipple direction

1 block (A type)

2 blocks (B type)

Drive side Subsidiary side

*1 Distance between the mechanical stopper and the stroke starting position.

*2 This indicates the block length when calculating the possible stroke range.
It is 216 mm (total) for a KR46 with 2 blocks in close contact with each other (B type, without QZ).

Stroke (mm) (stroke between mechanical stoppers)		Outer rail length (mm)	Overall length L ₁ (mm)	C (mm)	F (mm)	H (mm)	n	n ₁	Overall main unit mass (kg)	
Type A	Type B*								Type A	Type B
190 (208)	80 (98)	340	417	200	200	70	3	2	7.6	8.6
290 (308)	180 (198)	440	517	300	400	20	4	3	9	10
390 (408)	280 (298)	540	617	400	400	70	5	3	10.4	11.4
490 (508)	380 (398)	640	717	500	600	20	6	4	11.8	12.8
590 (608)	480 (498)	740	817	600	600	70	7	4	13.2	14.2
690 (708)	580 (598)	840	917	700	800	20	8	5	14.6	15.6
790 (808)	680 (698)	940	1017	800	800	70	9	5	16	17

*Indicates a value when two inner blocks are in close contact with each other.

KR46 With Cover, Motor Wrap

Model KR46□□A (with a Single Long Nut Block)

Model KR46□□B (with Two Long Nut Blocks)

For model number coding, see **A2-136**.

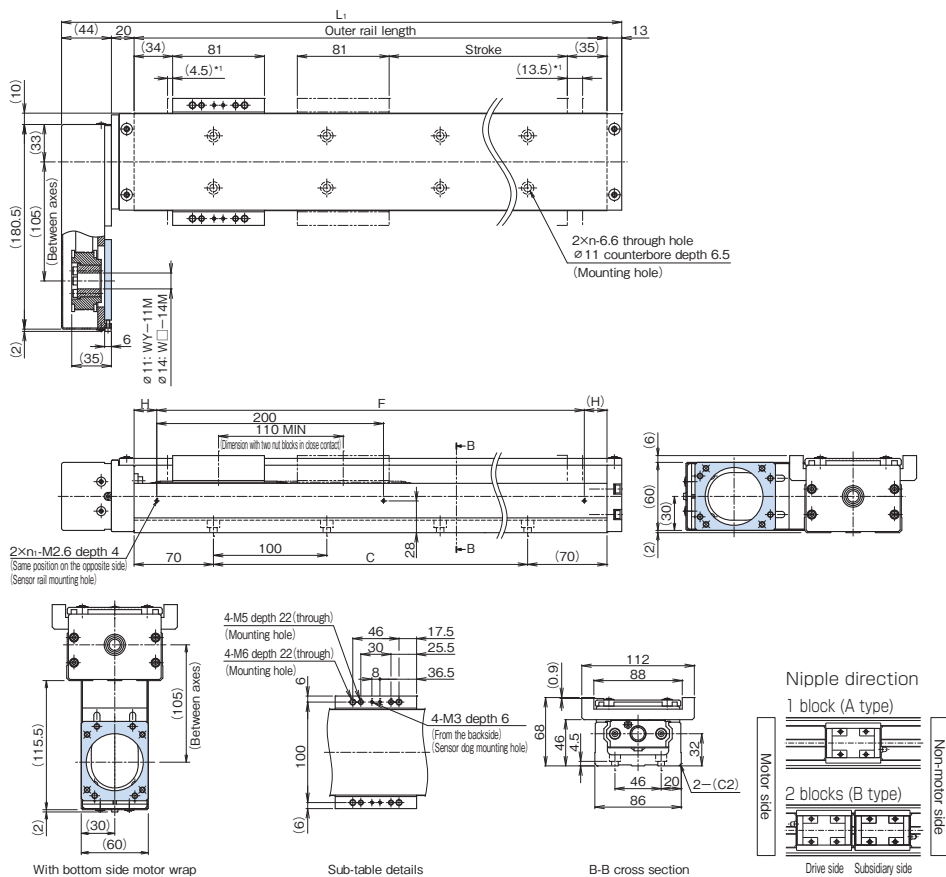

*1 Distance between the mechanical stopper and the stroke starting position.

Stroke (mm) (stroke between mechanical stoppers)		Outer rail length (mm)	Overall length L_1 (mm)	C (mm)	F (mm)	H (mm)	n	n_1	Overall main unit mass (kg)	
Type A	Type B [*]								Type A	Type B
190 (208)	80 (98)	340	417	200	200	70	3	2	8.6	10
290 (308)	180 (198)	440	517	300	400	20	4	3	10	11.4
390 (408)	280 (298)	540	617	400	400	70	5	3	11.5	12.9
490 (508)	380 (398)	640	717	500	600	20	6	4	13	14.4
590 (608)	480 (498)	740	817	600	600	70	7	4	14.5	15.9
690 (708)	580 (598)	840	917	700	800	20	8	5	16	17.4
790 (808)	680 (698)	940	1017	800	800	70	9	5	17.4	18.8

*Indicates a value when two inner blocks are in close contact with each other.

KR46 Without Cover, Direct Motor Coupling

Model KR46□□C (with a Single Short Nut Block)

Model KR46□□D (with Two Short Nut Blocks)

For model number coding, see **A2-136**.

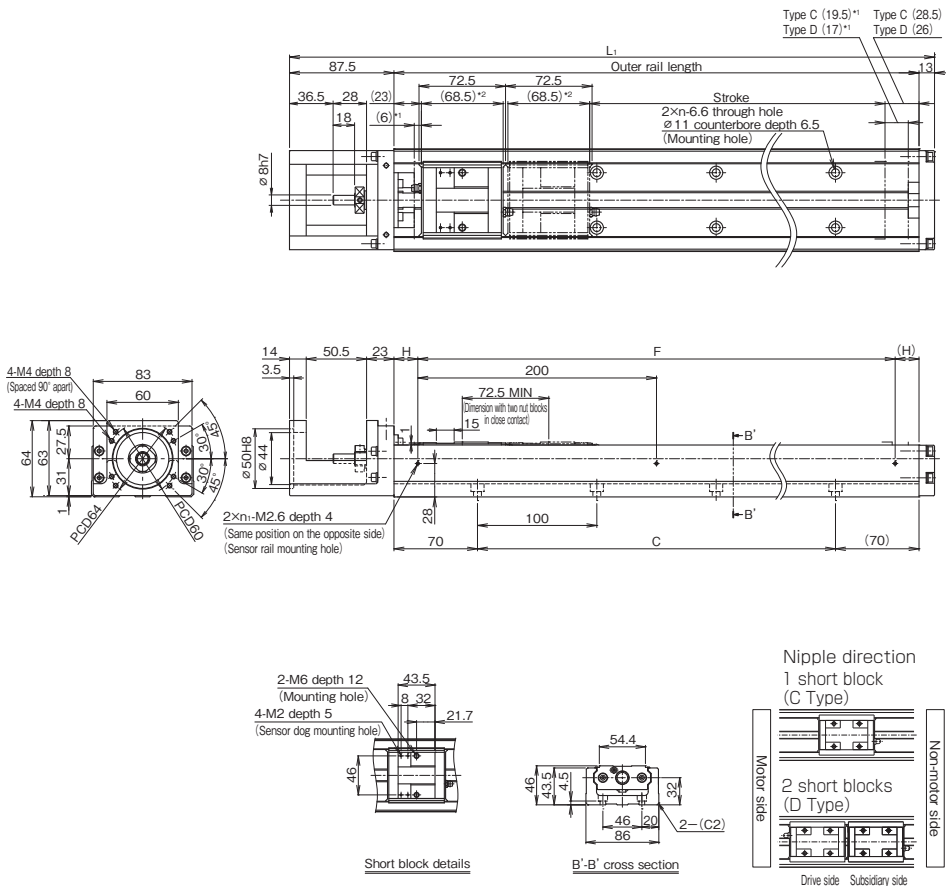

*1 Distance between the mechanical stopper and the stroke starting position.

*2 This indicates the short block length when calculating the possible stroke range.

It is 141 mm (total) for a KR46 with 2 short blocks in close contact with each other (D type, without QZ).

Stroke (mm) (stroke between mechanical stoppers)		Outer rail length (mm)	Overall length L_1 (mm)	C (mm)	F (mm)	H (mm)	n	n_1	Overall main unit mass (kg)	
Type C	Type D [*]								Type C	Type D
220 (245.5)	150 (173)	340	440.5	200	200	70	3	2	6.2	6.8
320 (345.5)	250 (273)	440	540.5	300	400	20	4	3	7.6	8.2
420 (445.5)	350 (373)	540	640.5	400	400	70	5	3	9	9.6
520 (545.5)	450 (473)	640	740.5	500	600	20	6	4	10.4	11
620 (645.5)	550 (573)	740	840.5	600	600	70	7	4	11.8	12.4
720 (745.5)	650 (673)	840	940.5	700	800	20	8	5	13.2	13.8
820 (845.5)	750 (773)	940	1040.5	800	800	70	9	5	14.6	15.2

*Indicates a value when two inner blocks are in close contact with each other.

KR46 With Cover, Direct Motor Coupling

Model KR46□□C (with a Single Short Nut Block)

Model KR46□□D (with Two Short Nut Blocks)

For model number coding, see **A2-136**.

Type C (19.5)*¹ Type C (41)
Type D (17)*¹ Type D (38.5)

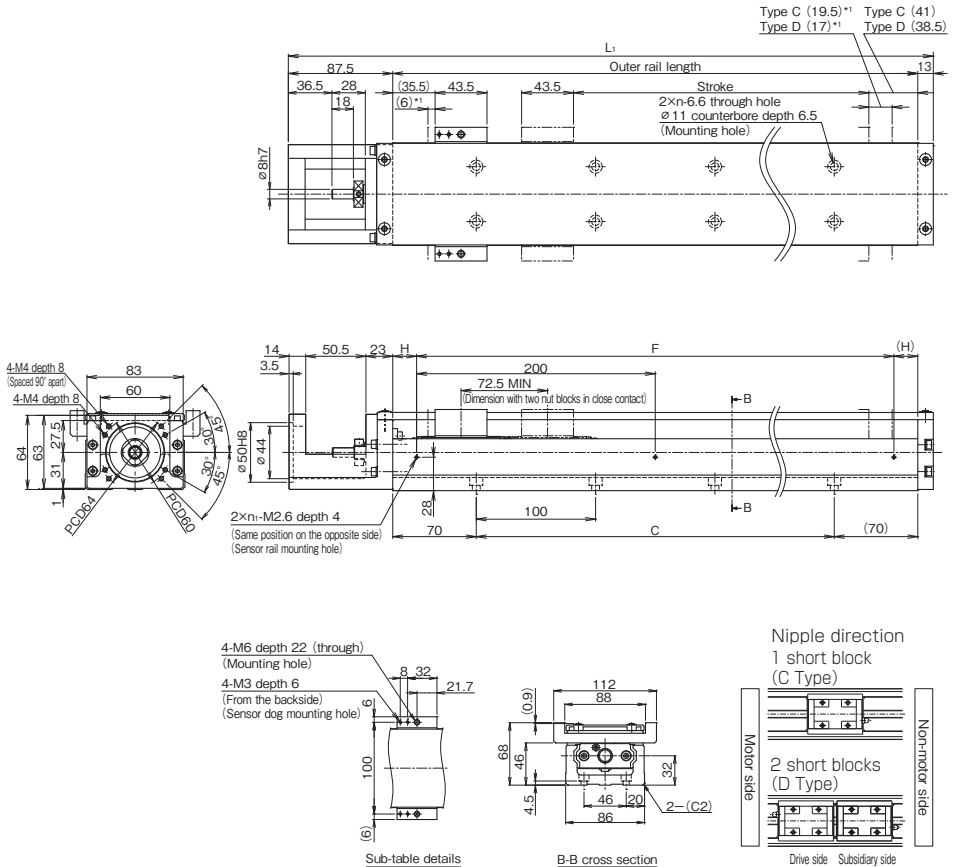

*1 Distance between the mechanical stopper and the stroke starting position.

Stroke (mm) (stroke between mechanical stoppers)		Outer rail length (mm)	Overall length L_1 (mm)	C (mm)	F (mm)	H (mm)	n	n_1	Overall main unit mass (kg)	
Type C	Type D ¹								Type C	Type D
220 (245.5)	150 (173)	340	440.5	200	200	70	3	2	6.9	7.7
320 (345.5)	250 (273)	440	540.5	300	400	20	4	3	8.4	9.2
420 (445.5)	350 (373)	540	640.5	400	400	70	5	3	9.9	10.7
520 (545.5)	450 (473)	640	740.5	500	600	20	6	4	11.4	12.2
620 (645.5)	550 (573)	740	840.5	600	600	70	7	4	12.9	13.7
720 (745.5)	650 (673)	840	940.5	700	800	20	8	5	14.3	15.1
820 (845.5)	750 (773)	940	1040.5	800	800	70	9	5	15.8	16.6

¹Indicates a value when two inner blocks are in close contact with each other.

KR46 Without Cover, Motor Wrap

Model KR46□□C (with a Single Short Nut Block)

Model KR46□□D (with Two Short Nut Blocks)

For model number coding, see **A2-136**.

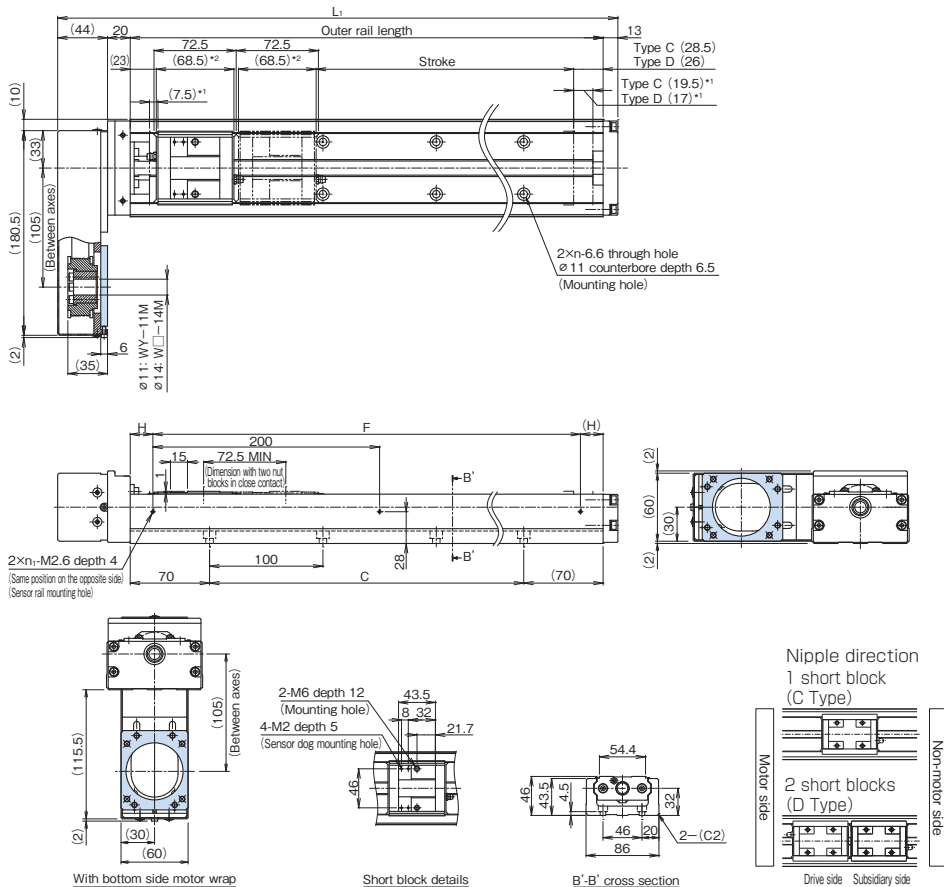

*1 Distance between the mechanical stopper and the stroke starting position.

*2 This indicates the short block length when calculating the possible stroke range.

It is 141 mm (total) for a KR46 with 2 short blocks in close contact with each other (D type, without Q2).

Stroke (mm) (stroke between mechanical stoppers)		Outer rail length (mm)	Overall length L ₁ (mm)	C (mm)	F (mm)	H (mm)	n	n ₁	Overall main unit mass (kg)	
Type C	Type D*								Type C	Type D
220 (245.5)	150 (173)	340	417	200	200	70	3	2	7.2	7.8
320 (345.5)	250 (273)	440	517	300	400	20	4	3	8.6	9.2
420 (445.5)	350 (373)	540	617	400	400	70	5	3	10	10.6
520 (545.5)	450 (473)	640	717	500	600	20	6	4	11.4	12
620 (645.5)	550 (573)	740	817	600	600	70	7	4	12.8	13.4
720 (745.5)	650 (673)	840	917	700	800	20	8	5	14.2	14.8
820 (845.5)	750 (773)	940	1017	800	800	70	9	5	15.6	16.2

*Indicates a value when two inner blocks are in close contact with each other.

KR46 With Cover, Motor Wrap

Model KR46□□C (with a Single Short Nut Block)

Model KR46□□D (with Two Short Nut Blocks)

For model number coding, see [A2-136](#).

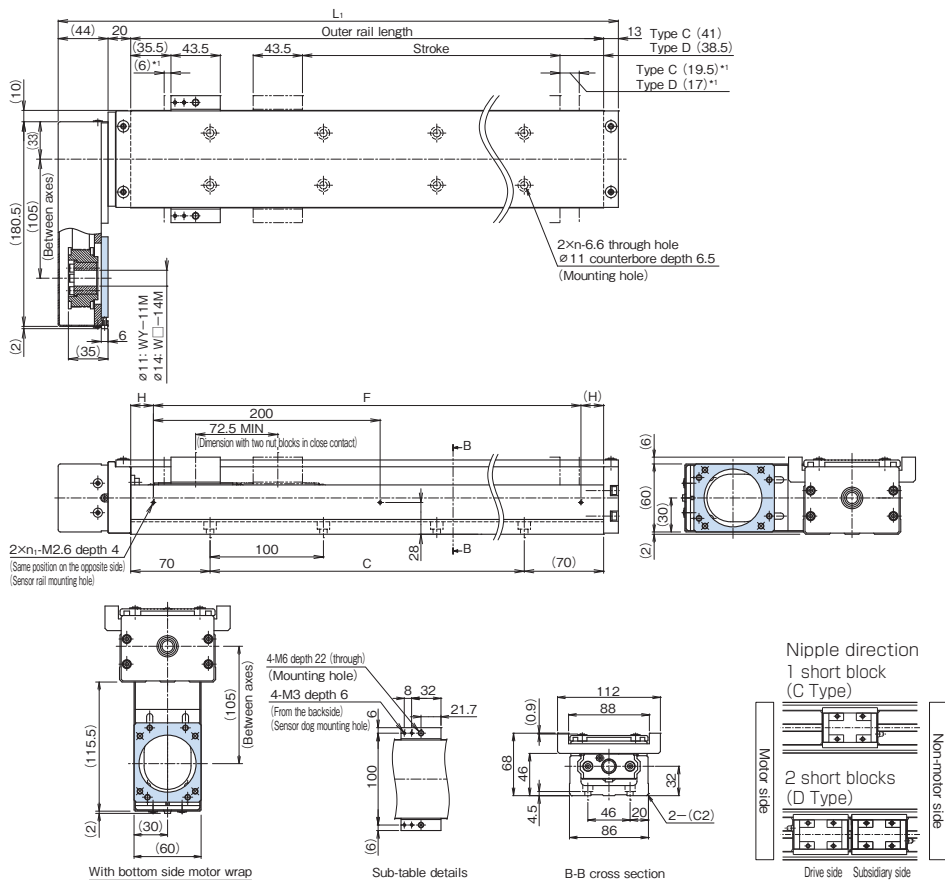

*1 Distance between the mechanical stopper and the stroke starting position.

Stroke (mm) (stroke between mechanical stoppers)		Outer rail length (mm)	Overall length L ₁ (mm)	C (mm)	F (mm)	H (mm)	n	n ₁	Overall main unit mass (kg)	
Type C	Type D [*]								Type C	Type D
220 (245.5)	150 (173)	340	417	200	200	70	3	2	8	8.8
320 (345.5)	250 (273)	440	517	300	400	20	4	3	9.4	10.2
420 (445.5)	350 (373)	540	617	400	400	70	5	3	10.9	11.7
520 (545.5)	450 (473)	640	717	500	600	20	6	4	12.4	13.2
620 (645.5)	550 (573)	740	817	600	600	70	7	4	13.9	14.7
720 (745.5)	650 (673)	840	917	700	800	20	8	5	15.4	16.2
820 (845.5)	750 (773)	940	1017	800	800	70	9	5	16.8	17.6

*Indicates a value when two inner blocks are in close contact with each other.

Options⇒ [A2-193](#)

THK [A2-181](#)

KR5 Without Cover, Direct Motor Coupling

Model KR5520A (with a Single Long Nut Block)

Model KR5520B (with Two Long Nut Blocks)

For model number coding, see **A2-136**.

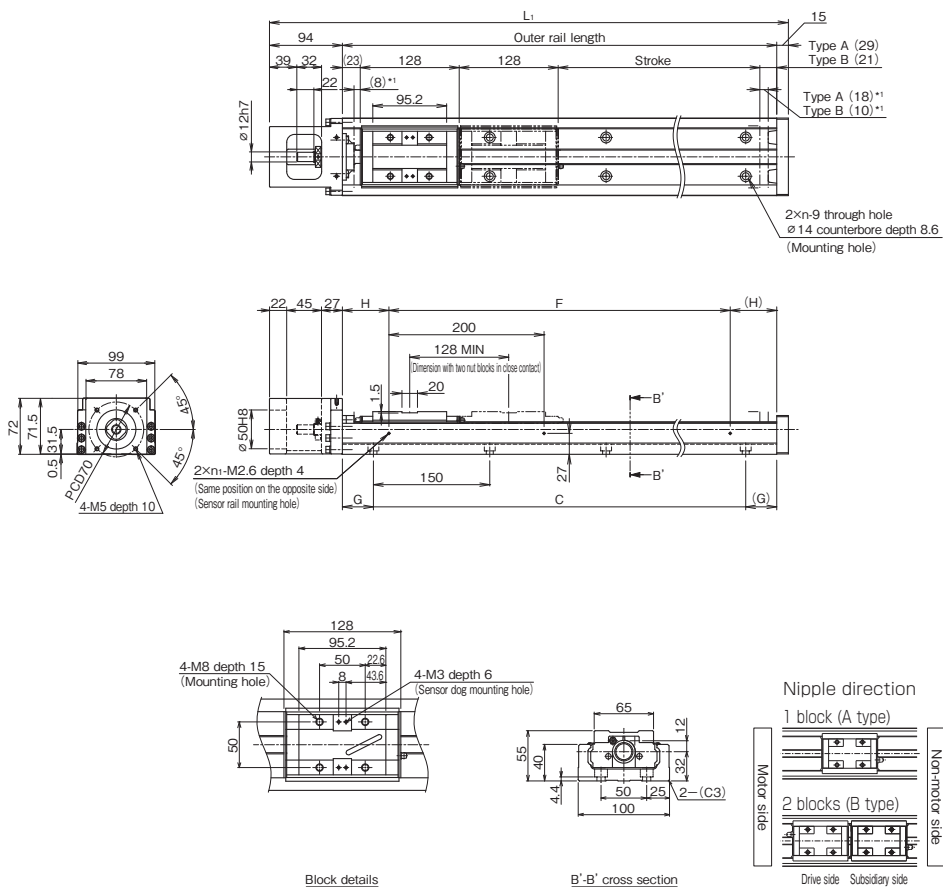

*1 Distance between the mechanical stopper and the stroke starting position.

Stroke (mm) (stroke between mechanical stoppers)		Outer rail length (mm)	Overall length L ₁ (mm)	C (mm)	G (mm)	F (mm)	H (mm)	n	n ₁	Overall main unit mass (kg)	
Type A	Type B [*]									Type A	Type B
800 (826)	680 (698)	980	1089	900	40	800	90	7	5	20.2	22
900 (926)	780 (798)	1080	1189	1050	15	1000	40	8	6	21.9	23.7
1000 (1026)	880 (898)	1180	1289	1050	65	1000	90	8	6	23.6	25.4
1100 (1126)	980 (998)	1280	1389	1200	40	1200	40	9	7	25.4	27.2
1200 (1226)	1080 (1098)	1380	1489	1350	15	1200	90	10	7	27.1	28.9

*Indicates a value when two inner blocks are in close contact with each other.

KR55 With Cover, Direct Motor Coupling

Model KR5520A (with a Single Long Nut Block)

Model KR5520B (with Two Long Nut Blocks)

For model number coding, see **A2-136**.

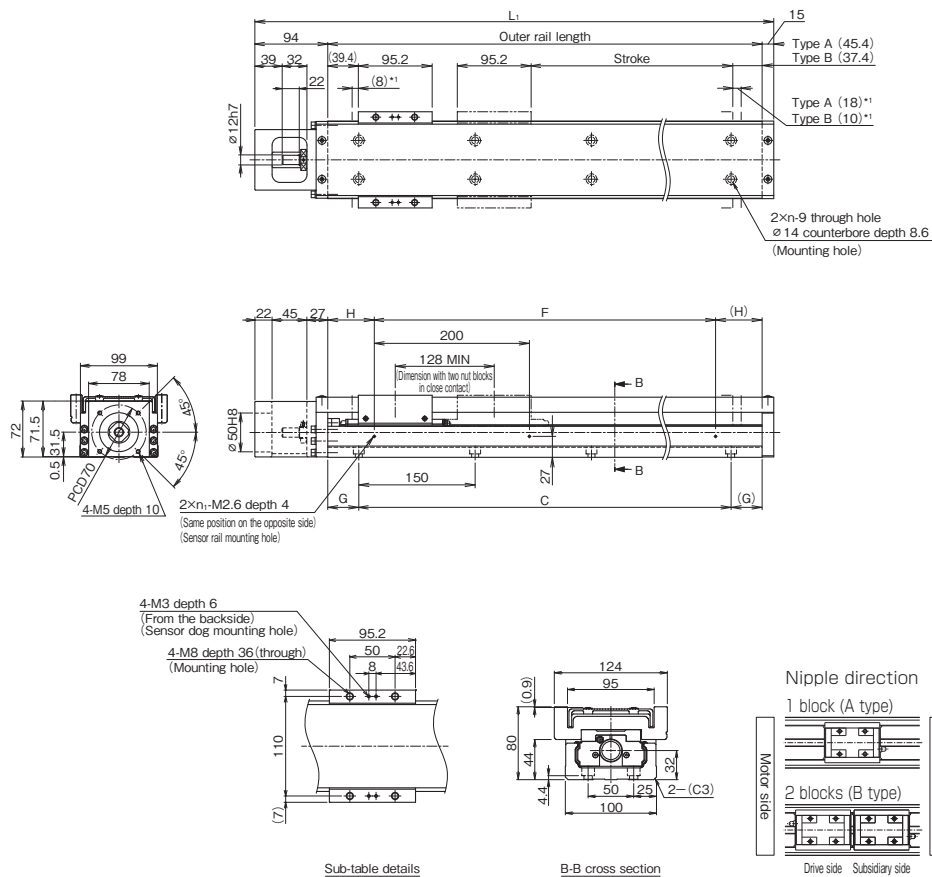

*1 Distance between the mechanical stopper and the stroke starting position.

Stroke (mm) (stroke between mechanical stoppers)		Outer rail length (mm)	Overall length L ₁ (mm)	C (mm)	G (mm)	F (mm)	H (mm)	n	n ₁	Overall main unit mass (kg)	
Type A	Type B*									Type A	Type B
800 (826)	680 (698)	980	1089	900	40	800	90	7	5	24.1	27.8
900 (926)	780 (798)	1080	1189	1050	15	1000	40	8	6	25.9	29.6
1000 (1026)	880 (898)	1180	1289	1050	65	1000	90	8	6	27.7	31.4
1100 (1126)	980 (998)	1280	1389	1200	40	1200	40	9	7	29.6	33.3
1200 (1226)	1080 (1098)	1380	1489	1350	15	1200	90	10	7	31.4	35.1

*Indicates a value when two inner blocks are in close contact with each other.

Options⇒ **A2-193**

THK **A2-183**

KR55 Without Cover, Motor Wrap Motor Flange Angle, 60×60

Model KR5520A (with a Single Long Nut Block)

Model KR5520B (with Two Long Nut Blocks)

For model number coding, see **A2-136**.

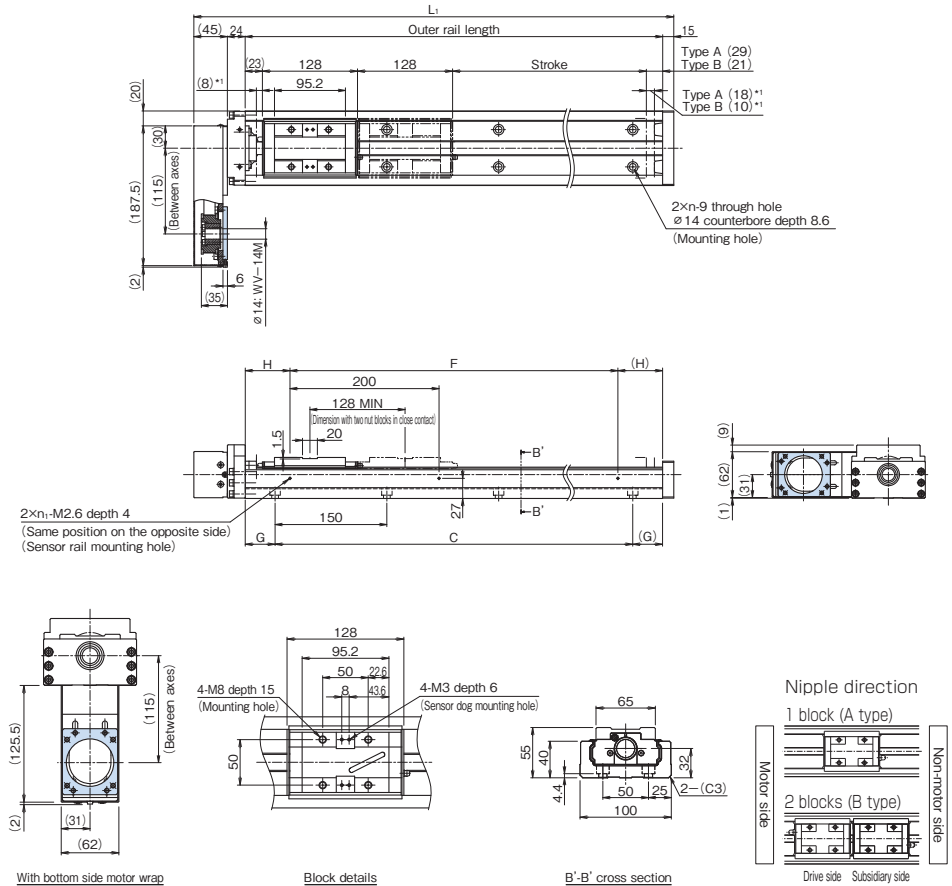

*1 Distance between the mechanical stopper and the stroke starting position.

Stroke (mm) (stroke between mechanical stoppers)		Outer rail length (mm)	Overall length L_1 (mm)	C (mm)	G (mm)	F (mm)	H (mm)	n	n ₁	Overall main unit mass (kg)	
Type A	Type B*									Type A	Type B
800 (826)	680 (698)	980	1064	900	40	800	90	7	5	21.1	22.9
900 (926)	780 (798)	1080	1164	1050	15	1000	40	8	6	22.8	24.6
1000 (1026)	880 (898)	1180	1264	1050	65	1000	90	8	6	24.5	26.3
1100 (1126)	980 (998)	1280	1364	1200	40	1200	40	9	7	26.3	28.1
1200 (1226)	1080 (1098)	1380	1464	1350	15	1200	90	10	7	28	29.8

*Indicates a value when two inner blocks are in close contact with each other.

KR55 With Cover, Motor Wrap Motor Flange Angle, 60×60

Model KR5520A (with a Single Long Nut Block)

Model KR5520B (with Two Long Nut Blocks)

For model number coding, see **A2-136**.

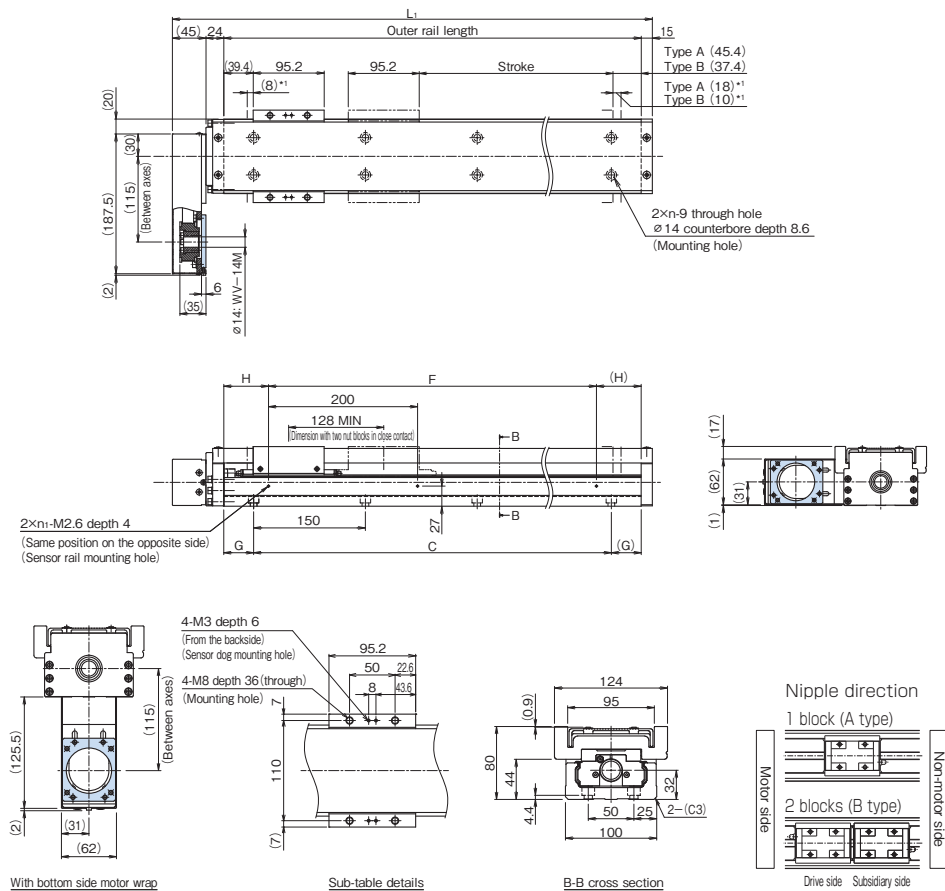

*1 Distance between the mechanical stopper and the stroke starting position.

Stroke (mm) (stroke between mechanical stoppers)		Outer rail length (mm)	Overall length L_1 (mm)	C (mm)	G (mm)	F (mm)	H (mm)	n	n_1	Overall main unit mass (kg)	
Type A	Type B [*]									Type A	Type B
800 (826)	680 (698)	980	1064	900	40	800	90	7	5	25	28.7
900 (926)	780 (798)	1080	1164	1050	15	1000	40	8	6	26.8	30.5
1000 (1026)	880 (898)	1180	1264	1050	65	1000	90	8	6	28.6	32.3
1100 (1126)	980 (998)	1280	1364	1200	40	1200	40	9	7	30.5	34.2
1200 (1226)	1080 (1098)	1380	1464	1350	15	1200	90	10	7	32.3	36

*Indicates a value when two inner blocks are in close contact with each other.

Options⇒ **A2-193**

THK **A2-185**

KR55 Without Cover, Motor Wrap Motor Flange Angle, 80×80

Model KR5520A (with a Single Long Nut Block)

Model KR5520B (with Two Long Nut Blocks)

For model number coding, see **A2-136**.

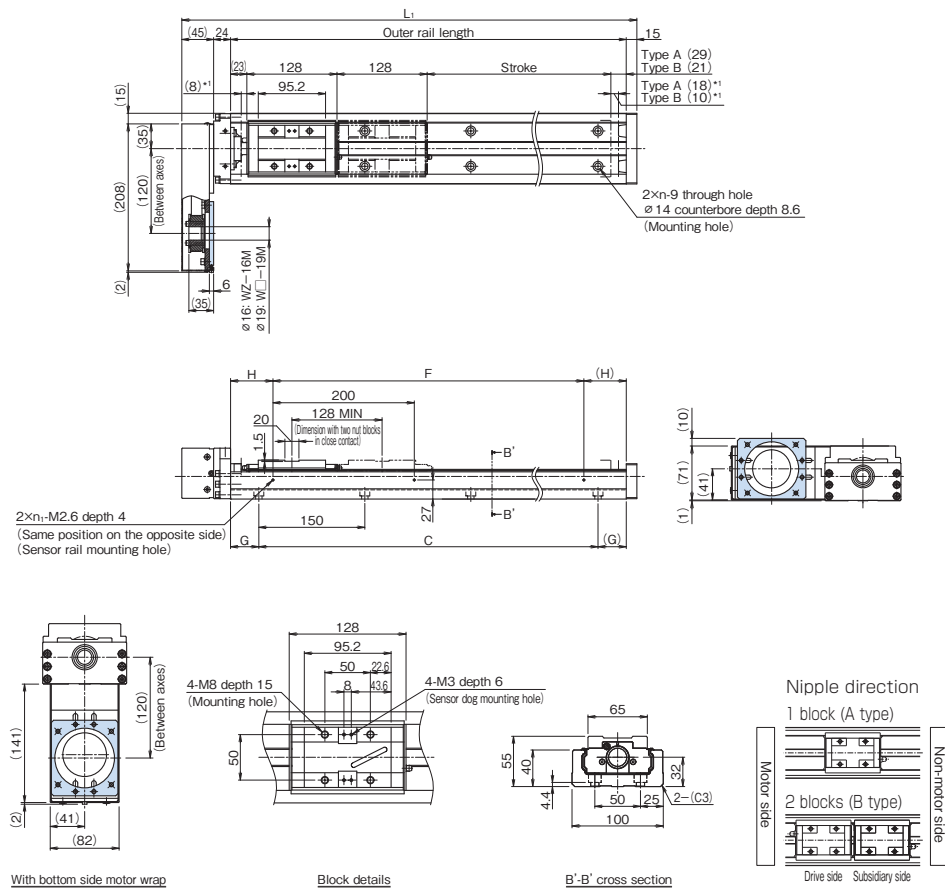

*1 Distance between the mechanical stopper and the stroke starting position.

Stroke (mm) (stroke between mechanical stoppers)		Outer rail length (mm)	Overall length L ₁ (mm)	C (mm)	G (mm)	F (mm)	H (mm)	n	n ₁	Overall main unit mass (kg)	
Type A	Type B*									Type A	Type B
800 (826)	680 (698)	980	1064	900	40	800	90	7	5	21.1	22.9
900 (926)	780 (798)	1080	1164	1050	15	1000	40	8	6	22.8	24.6
1000 (1026)	880 (898)	1180	1264	1050	65	1000	90	8	6	24.5	26.3
1100 (1126)	980 (998)	1280	1364	1200	40	1200	40	9	7	26.3	28.1
1200 (1226)	1080 (1098)	1380	1464	1350	15	1200	90	10	7	28	29.8

*Indicates a value when two inner blocks are in close contact with each other.

KR55 With Cover, Motor Wrap Motor Flange Angle, 80×80

Model KR5520A (with a Single Long Nut Block)

Model KR5520B (with Two Long Nut Blocks)

For model number coding, see **A2-136**.

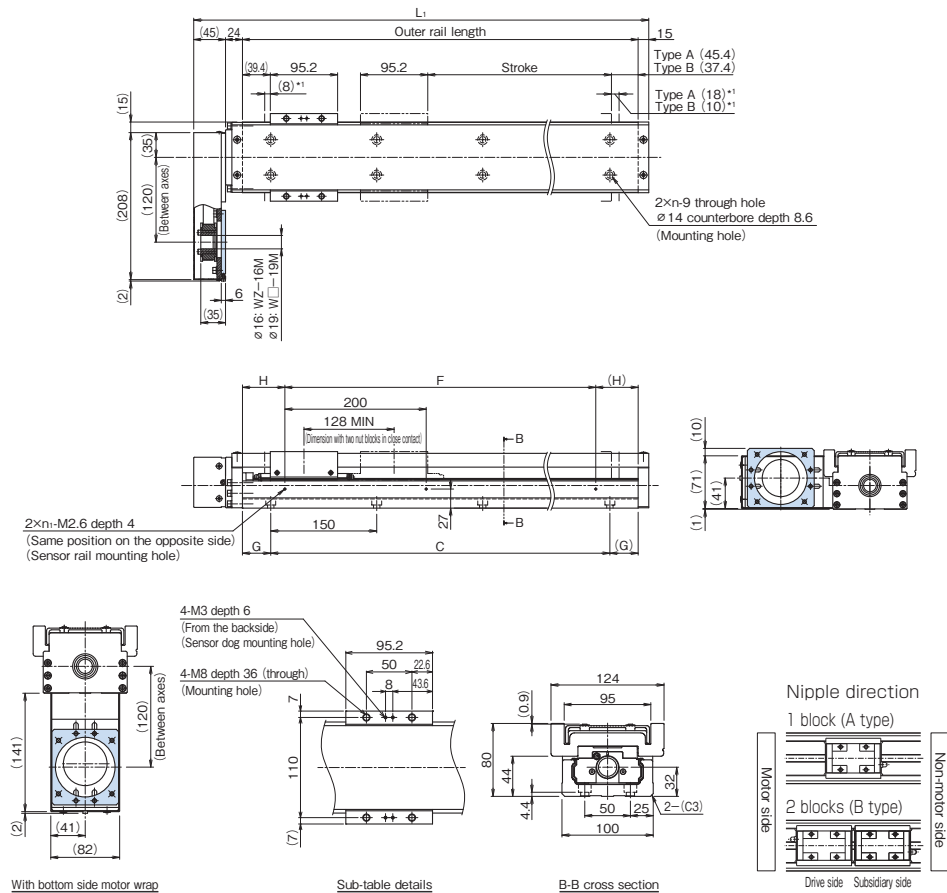

*1 Distance between the mechanical stopper and the stroke starting position.

Stroke (mm) (stroke between mechanical stoppers)		Outer rail length (mm)	Overall length L_1 (mm)	C (mm)	G (mm)	F (mm)	H (mm)	n	n_1	Overall main unit mass (kg)	
Type A	Type B [*]									Type A	Type B
800 (826)	680 (698)	980	1064	900	40	800	90	7	5	25	28.7
900 (926)	780 (798)	1080	1164	1050	15	1000	40	8	6	26.8	30.5
1000 (1026)	880 (898)	1180	1264	1050	65	1000	90	8	6	28.6	32.3
1100 (1126)	980 (998)	1280	1364	1200	40	1200	40	9	7	30.5	34.2
1200 (1226)	1080 (1098)	1380	1464	1350	15	1200	90	10	7	32.3	36

*Indicates a value when two inner blocks are in close contact with each other.

Options⇒ **A2-193**

THK **A2-187**

KR65 Without Cover, Direct Motor Coupling

Model KR6525A (with a Single Long Nut Block)

Model KR6525B (with Two Long Nut Blocks)

For model number coding, see **A2-136**.

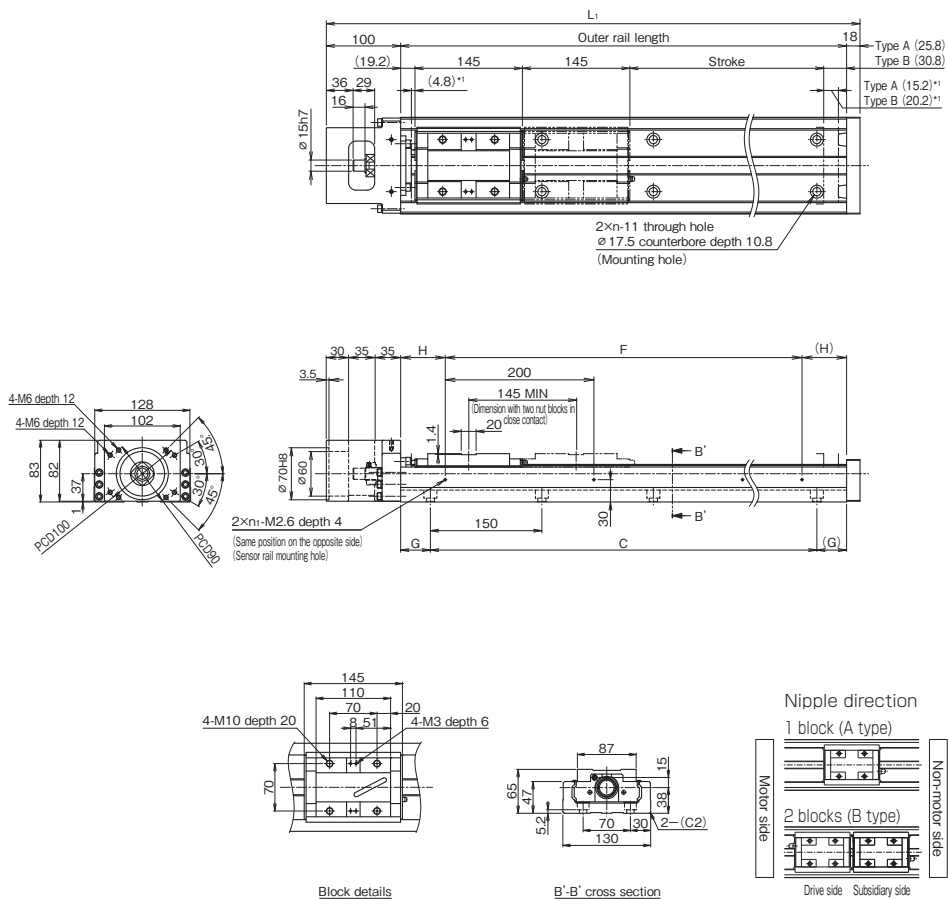

*1 Distance between the mechanical stopper and the stroke starting position.

Stroke (mm) (stroke between mechanical stoppers)		Outer rail length (mm)	Overall length L_1 (mm)	C (mm)	G (mm)	F (mm)	H (mm)	n	n_1	Overall main unit mass (kg)	
Type A	Type B*									Type A	Type B
790 (810)	640 (665)	980	1098	900	40	800	90	7	5	32.2	35.5
990 (1010)	840 (865)	1180	1298	1050	65	1000	90	8	6	37.6	40.9
1190 (1210)	1040 (1065)	1380	1498	1200	90	1200	90	9	7	43	46.3
1490 (1510)	1340 (1365)	1680	1798	1500	90	1600	40	11	9	51.1	54.4

*Indicates a value when two inner blocks are in close contact with each other.

KR65 With Cover, Direct Motor Coupling

Model KR6525A (with a Single Long Nut Block)

Model KR6525B (with Two Long Nut Blocks)

For model number coding, see **A2-136**.

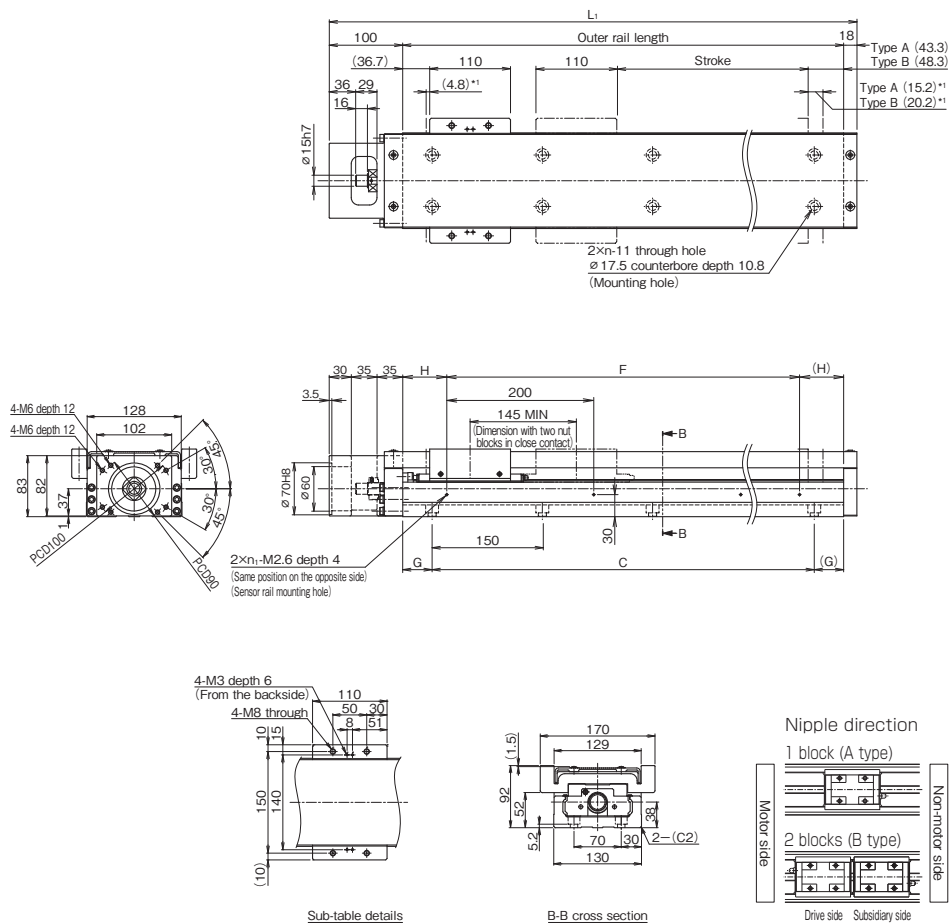

*1 Distance between the mechanical stopper and the stroke starting position.

Stroke (mm) (stroke between mechanical stoppers)		Outer rail length (mm)	Overall length L_1 (mm)	C (mm)	G (mm)	F (mm)	H (mm)	n	n_1	Overall main unit mass (kg)	
Type A	Type B*									Type A	Type B
790 (810)	640 (665)	980	1098	900	40	800	90	7	5	38.6	45.2
990 (1010)	840 (865)	1180	1298	1050	65	1000	90	8	6	44.3	50.9
1190 (1210)	1040 (1065)	1380	1498	1200	90	1200	90	9	7	50	56.6
1490 (1510)	1340 (1365)	1680	1798	1500	90	1600	40	11	9	58.5	65.1

*Indicates a value when two inner blocks are in close contact with each other.

KR65 Without Cover, Motor Wrap

Model KR6525A (with a Single Long Nut Block)

Model KR6525B (with Two Long Nut Blocks)

For model number coding, see **A2-136**.

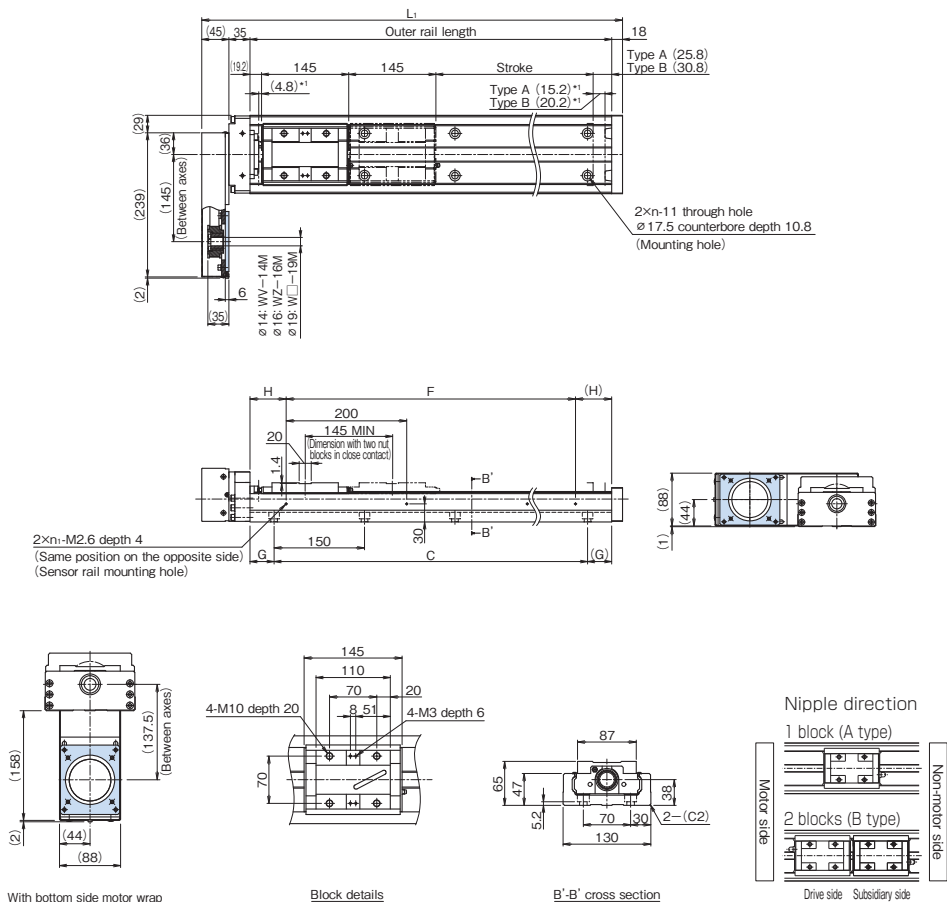

With bottom side motor wrap

Block details

B-B' cross section

*1 Distance between the mechanical stopper and the stroke starting position.

Stroke (mm) (stroke between mechanical stoppers)		Outer rail length (mm)	Overall length L_1 (mm)	C (mm)	G (mm)	F (mm)	H (mm)	n	n_1	Overall main unit mass (kg)	
Type A	Type B									Type A	Type B
790 (810)	640 (665)	980	1078	900	40	800	90	7	5	33.9	37.2
990 (1010)	840 (865)	1180	1278	1050	65	1000	90	8	6	39.3	42.6
1190 (1210)	1040 (1065)	1380	1478	1200	90	1200	90	9	7	44.7	48
1490 (1510)	1340 (1365)	1680	1778	1500	90	1600	40	11	9	52.7	56

*Indicates a value when two inner blocks are in close contact with each other.

KR65 With Cover, Motor Wrap

Model KR6525A (with a Single Long Nut Block)

Model KR6525B (with Two Long Nut Blocks)

For model number coding, see **A2-136**.

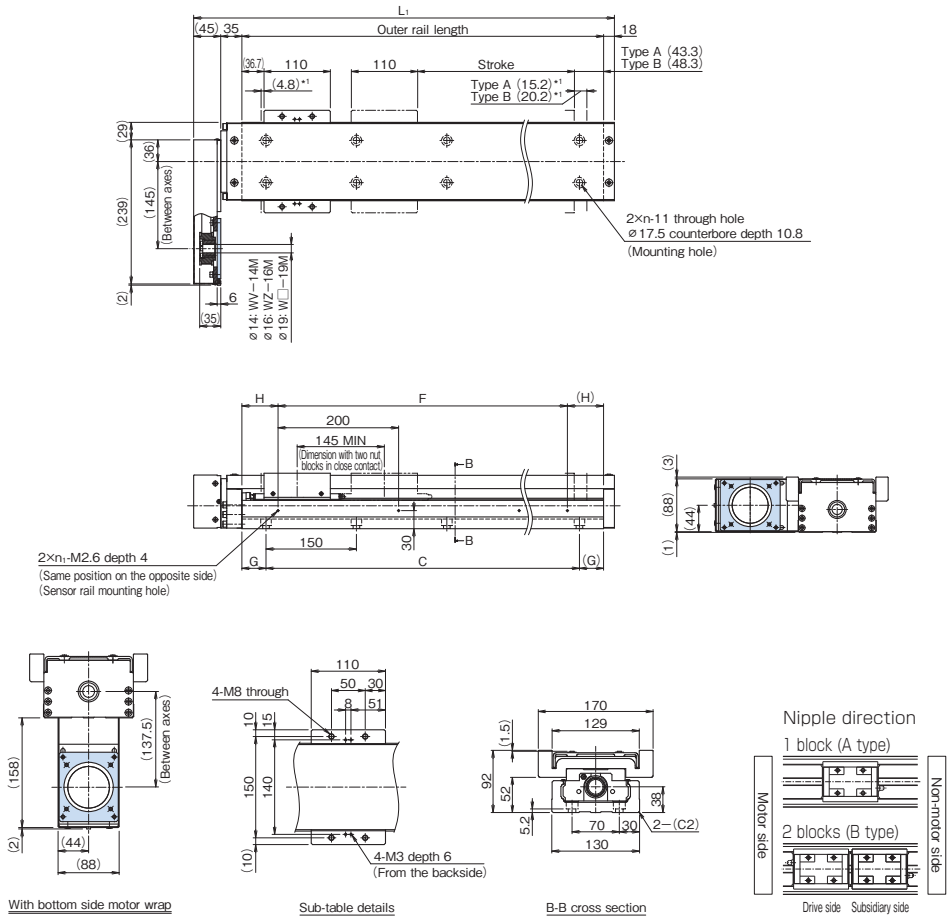

*1 Distance between the mechanical stopper and the stroke starting position.

Stroke (mm) (stroke between mechanical stoppers)		Outer rail length (mm)	Overall length L ₁ (mm)	C (mm)	G (mm)	F (mm)	H (mm)	n	n ₁	Overall main unit mass (kg)	
Type A	Type B*									Type A	Type B
790 (810)	640 (665)	980	1078	900	40	800	90	7	5	40.3	46.9
990 (1010)	840 (865)	1180	1278	1050	65	1000	90	8	6	46	52.6
1190 (1210)	1040 (1065)	1380	1478	1200	90	1200	90	9	7	51.7	58.3
1490 (1510)	1340 (1365)	1680	1778	1500	90	1600	40	11	9	60.2	66.8

*Indicates a value when two inner blocks are in close contact with each other.

Mass of Moving Elements

Table13 shows the mass of the inner block and top table of model KR.

Table13 Mass of the Inner Block and Top Table of KR

Unit: kg

Model No.	Long nut block types				Short nut block types			
	A/B	Inner block	Top table	Total mass	C/D	Inner block	Top table	Total mass
KR15	Type A	0.04	0.03	0.07	Type C	—	—	—
	Type B	0.08	0.06	0.14	Type D	—	—	—
KR20	Type A	0.08	0.05	0.13	Type C	—	—	—
	Type B	0.16	0.1	0.26	Type D	—	—	—
KR26	Type A	0.19	0.09	0.28	Type C	—	—	—
	Type B	0.38	0.18	0.56	Type D	—	—	—
KR30H	Type A	0.4	0.2	0.6	Type C	0.2	0.1	0.3
	Type B	0.8	0.4	1.2	Type D	0.4	0.2	0.6
KR33	Type A	0.4	0.2	0.6	Type C	0.2	0.1	0.3
	Type B	0.8	0.4	1.2	Type D	0.4	0.2	0.6
KR45H	Type A	1.0	0.4	1.4	Type C	0.6	0.2	0.8
	Type B	2.0	0.8	2.8	Type D	1.2	0.4	1.6
KR46	Type A	1.0	0.4	1.4	Type C	0.6	0.2	0.8
	Type B	2.0	0.8	2.8	Type D	1.2	0.4	1.6
KR55	Type A	1.8	1.9	3.7	Type C	—	—	—
	Type B	3.6	3.8	7.4	Type D	—	—	—
KR65	Type A	3.3	3.3	6.6	Type C	—	—	—
	Type B	6.6	6.6	13.2	Type D	—	—	—

QZ Lubricator (compatible models: KR33, KR46, KR55, KR65)

The QZ Lubricator for KR feeds the proper amount of lubricant to the outer rail and ball screw shaft raceway. This allows an oil film to be constantly formed between the balls and the raceway, significantly extending the lubrication maintenance interval.

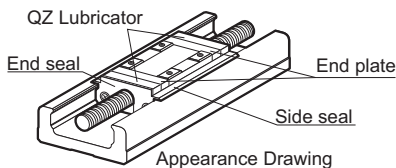

[Features]

- Since it supplements lost oil, the lubrication maintenance interval can be significantly extended.
- This is an eco-friendly lubrication system that does not contaminate the surrounding area because it feeds the correct amount of lubricant to the ball raceway.

[KR-QZ Configuration]

Symbol	Block type	Description
QZ	A/B/C/D	QZ with all blocks both sides specification
QZA	A/C	QZ with fixed side specification
QZB	A/C	QZ with supported side specification
QZAD	B/D	QZ with fixed side (inner block with screw) + QZ with supported side (free block) specifications

Note) The QZ specification does not include a grease nipple. Contact THK if a grease nipple is required.

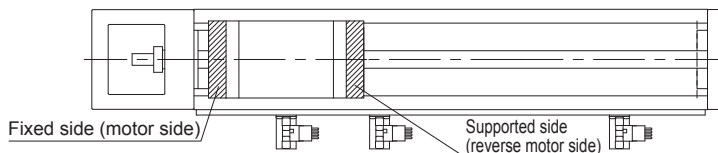

Constitution	QZ	QZA	QZB	QZAD
Type A (with a Single Long Nut Block)	 Fixed side Supported side	 Fixed side Supported side	 Fixed side Supported side	—
Type B (with Two Long Nut Blocks)	 Fixed side Supported side	—	—	 Fixed side Supported side
Type C (with a Single Short Nut Block)	 Fixed side Supported side	 Fixed side Supported side	 Fixed side Supported side	—
Type D (with Two Short Nut Blocks)	 Fixed side Supported side	—	—	 Fixed side Supported side

[Dimensions with QZ Lubricator]

Code: QZ (with cover)

Model No. KR33/46/55/65

Block type : A/B/C/D

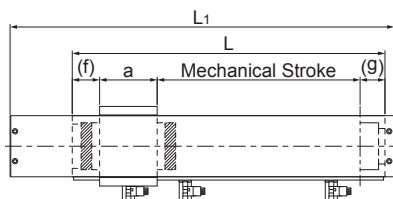

Block type A/C

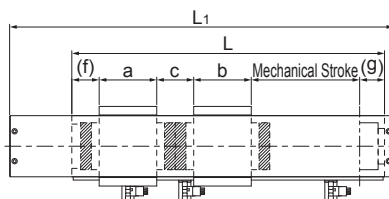

Block type B/D

Unit: mm

Model No.	Block type	Overall length L_1	Outer rail length L	Stroke ^{*1,2}	a	b	C	f	g
KR33	A	220	150	—	54	—	—	33	27.5
		270	200	75(85.5)					
		370	300	175(185.5)					
		470	400	275(285.5)					
		570	500	375(385.5)					
		670	600	475(485.5)					
	770	700	575(585.5)						
	B	220	150	—	54	54	48	33	27.5
		270	200	—					
		370	300	70(83.5)					
		470	400	170(183.5)					
		570	500	270(283.5)					
		670	600	370(383.5)					
	770	700	470(483.5)						
	C	220	150	50(61)	28.5	—	—	33	27.5
		270	200	100(111)					
		370	300	200(211)					
		470	400	300(311)					
		570	500	400(411)					
		670	600	500(511)					
	770	700	600(611)						
	D	220	150	—	28.5	28.5	48	33	27.5
		270	200	—					
		370	300	125(134.5)					
470		400	225(234.5)						
570		500	325(334.5)						
670		600	425(434.5)						
770	700	525(534.5)							

*1 The value in the parentheses represents the maximum stroke.

*2 The strokes for block types B and D are the values when in contact with the inner block.

Unit: mm

Model No.	Block type	Overall length L ₁	Outer rail length L	Stroke ^{*1,2}	a	b	C	f	g	
KR46	A	440.5	340	160(178)	81	—	—	44.5	36.5	
		540.5	440	260(278)						
		640.5	540	360(378)						
		740.5	640	460(478)						
		840.5	740	560(578)						
		940.5	840	660(678)						
	B	1040.5	940	760(778)	81	81	59	44.5	36.5	
		440.5	340	—						
		540.5	440	120(138)						
		640.5	540	220(238)						
		740.5	640	320(338)						
		840.5	740	420(438)						
	C	940.5	840	520(538)	43.5	—	—	44.5	36.5	
		1040.5	940	620(638)						
		440.5	340	190(215.5)						
		540.5	440	290(315.5)						
		640.5	540	390(415.5)						
		740.5	640	490(515.5)						
	D	840.5	740	590(615.5)	43.5	43.5	59	44.5	36.5	
		940.5	840	690(715.5)						
		1040.5	940	790(815.5)						
		440.5	340	90(113)						
		540.5	440	190(213)						
		640.5	540	290(313)						
	KR55	A	740.5	640	490(515.5)	95.2	—	—	47.4	43.4
			840.5	740	590(615.5)					
			940.5	840	690(715.5)					
			1040.5	940	790(815.5)					
1089			980	770(794)						
B		1189	1080	870(894)	95.2	95.2	64.8	47.4	43.4	
		1289	1180	970(994)						
		1389	1280	1070(1094)						
		1489	1380	1170(1194)						
		1089	980	615(634)						
KR65	A	1189	1080	715(734)	110	—	—	47.9	44.1	
		1289	1180	815(834)						
		1389	1280	915(934)						
		1489	1380	1015(1034)						
	B	1098	980	760(778)	110	110	67	47.9	44.1	
		1298	1180	960(978)						
		1498	1380	1160(1178)						
		1798	1680	1460(1478)						
		1098	980	580(601)						
		1298	1180	780(801)						
1498	1380	980(1001)								
1798	1680	1280(1301)								

*1 The value in the parentheses represents the maximum stroke.

*2 The strokes for block types B and D are the values when in contact with the inner block.

Code: QZ (without cover)
 Model No. : KR33/46/55/65
 Block type : A/B/C/D

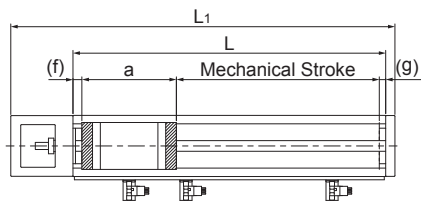

Block type A/C

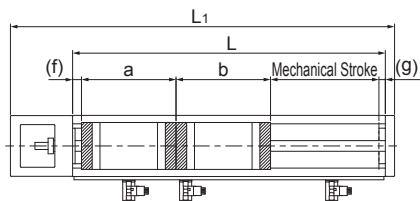

Block type B/D

Unit: mm

Model No.	Block type	Overall length L_1	Outer rail length L	Stroke ^{*1,2}	a^{*3}	b^{*3}	f	g
KR33	A	220	150	—	102 (98)	—	11	5.5
		270	200	75(85.5)				
		370	300	175(185.5)				
		470	400	275(285.5)				
		570	500	375(385.5)				
		670	600	475(485.5)				
	770	700	575(585.5)					
	B	220	150	—	102 (100)	102 (100)	11	5.5
		270	200	—				
		370	300	70(83.5)				
		470	400	170(183.5)				
		570	500	270(283.5)				
		670	600	370(383.5)				
	770	700	470(483.5)					
	C	220	150	50(61)	76.5 (72.5)	—	11	5.5
		270	200	100(111)				
		370	300	200(211)				
		470	400	300(311)				
		570	500	400(411)				
		670	600	500(511)				
	770	700	600(611)					
	D	220	150	—	76.5 (74.5)	76.5 (74.5)	11	5.5
		270	200	—				
		370	300	125(134.5)				
470		400	225(234.5)					
570		500	325(334.5)					
670		600	425(434.5)					
770	700	525(534.5)						

*1 The value in the parentheses represents the maximum stroke.

*2 The strokes for block types B and D are the values when in contact with the inner block.

*3 () indicates the length of the inner block when calculating the allowed stroke range.

Unit: mm

Model No.	Block type	Overall length L ₁	Outer rail length L	Stroke*1,2	a ³	b ³	f	g					
KR46	A	440.5	340	160(178)	140 (136)	—	17	9					
		540.5	440	260(278)									
		640.5	540	360(378)									
		740.5	640	460(478)									
		840.5	740	560(578)									
		940.5	840	660(678)									
	1040.5	940	760(778)										
	B	440.5	340	—	140 (138)	140 (138)	17	9					
		540.5	440	120(138)									
		640.5	540	220(238)									
		740.5	640	320(338)									
		840.5	740	420(438)									
		940.5	840	520(538)									
		1040.5	940	620(638)									
		C	440.5	340					190(215.5)	102.5 (98.5)	—	17	9
			540.5	440					290(315.5)				
			640.5	540					390(415.5)				
	740.5		640	490(515.5)									
	840.5		740	590(615.5)									
	940.5		840	690(715.5)									
	1040.5	940	790(815.5)										
	D	440.5	340	90(113)	102.5 (100.5)	102.5 (100.5)	17	9					
		540.5	440	190(213)									
		640.5	540	290(313)									
740.5		640	390(413)										
840.5		740	490(513)										
940.5		840	590(613)										
1040.5	940	690(713)											
KR55	A	1089	980	770(794)	160	—	15	11					
		1189	1080	870(894)									
		1289	1180	970(994)									
		1389	1280	1070(1094)									
		1489	1380	1170(1194)									
	B	1089	980	615(634)	160	160	15	11					
		1189	1080	715(734)									
		1289	1180	815(834)									
KR65	A	1289	1180	960(978)	177	—	14.4	10.6					
		1498	1380	1160(1178)									
		1798	1680	1460(1478)									
		1098	980	760(778)									
	B	1098	980	580(601)	177	177	14.4	10.6					
		1298	1180	780(801)									
		1498	1380	980(1001)									
		1798	1680	1280(1301)									

*1 The value in the parentheses represents the maximum stroke.

*2 The strokes for block types B and D are the values when in contact with the inner block.

*3 () indicates the length of the inner block when calculating the allowed stroke range.

Code: QZA (with cover)

Model No. : KR33/46/55/65

Block type : A/C

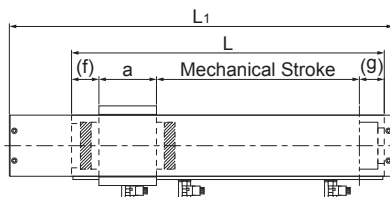

Block type A/C

Unit: mm

Model No.	Block type	Overall length L_1	Outer rail length L	Stroke ^{*1}	a	f	g
KR33	A	220	150	—	54	33	14.5
		270	200	85(98.5)			
		370	300	185(198.5)			
		470	400	285(298.5)			
		570	500	385(398.5)			
		670	600	485(498.5)			
	770	700	585(598.5)				
	C	220	150	60(74)	28.5	33	14.5
		270	200	110(124)			
		370	300	210(224)			
		470	400	310(324)			
		570	500	410(424)			
670		600	510(524)				
770	700	610(624)					
KR46	A	440.5	340	175(193)	81	44.5	21.5
		540.5	440	275(293)			
		640.5	540	375(393)			
		740.5	640	475(493)			
		840.5	740	575(593)			
		940.5	840	675(693)			
	1040.5	940	775(793)				
	C	440.5	340	205(230.5)	43.5	44.5	21.5
		540.5	440	305(330.5)			
		640.5	540	405(430.5)			
		740.5	640	505(530.5)			
		840.5	740	605(630.5)			
940.5		840	705(730.5)				
1040.5	940	805(830.5)					
KR55	A	1089	980	785(810)	95.2	47.4	27.4
		1189	1080	885(910)			
		1289	1180	985(1010)			
		1389	1280	1085(1110)			
		1489	1380	1185(1210)			
KR65	A	1098	980	775(794)	110	47.9	28.1
		1298	1180	975(994)			
		1498	1380	1175(1194)			
		1798	1680	1475(1494)			

Note) Block types B and D cannot be selected for QZA.

*1 The value in the parentheses represents the maximum stroke.

Code: QZA (without cover)
 Model No. : KR33/46/55/65
 Block type : A/C

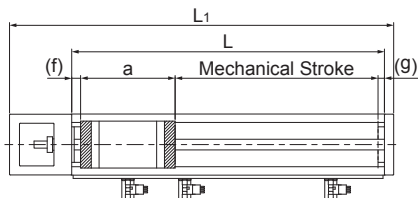

Block type A/C

Unit: mm

Model No.	Block type	Overall length L ₁	Outer rail length L	Stroke ^{*1}	a ^{*2}	f	g
KR33	A	220	150	—	89 (85)	11	5.5
		270	200	85(98.5)			
		370	300	185(198.5)			
		470	400	285(298.5)			
		570	500	385(398.5)			
		670	600	485(498.5)			
	770	700	585(598.5)				
	C	220	150	60(74)	63.5 (59.5)	11	5.5
		270	200	110(124)			
		370	300	210(224)			
		470	400	310(324)			
		570	500	410(424)			
670		600	510(524)				
770	700	610(624)					
KR46	A	440.5	340	175(193)	125 (121)	17	9
		540.5	440	275(293)			
		640.5	540	375(393)			
		740.5	640	475(493)			
		840.5	740	575(593)			
		940.5	840	675(693)			
	1040.5	940	775(793)				
	C	440.5	340	205(230.5)	87.5 (83.5)	17	9
		540.5	440	305(330.5)			
		640.5	540	405(430.5)			
		740.5	640	505(530.5)			
		840.5	740	605(630.5)			
940.5		840	705(730.5)				
1040.5	940	805(830.5)					
KR55	A	1089	980	785(810)	144	15	11
		1189	1080	885(910)			
		1289	1180	985(1010)			
		1389	1280	1085(1110)			
		1489	1380	1185(1210)			
KR65	A	1098	980	775(794)	161	14.4	10.6
		1298	1180	975(994)			
		1498	1380	1175(1194)			
		1798	1680	1475(1494)			

Note) Block types B and D cannot be selected for QZA.

*1 The value in the parentheses represents the maximum stroke.

*2 () indicates the length of the inner block when calculating the allowed stroke range.

Code: QZB (with cover)

Model No. : KR33/46/55/65

Block type : A/C

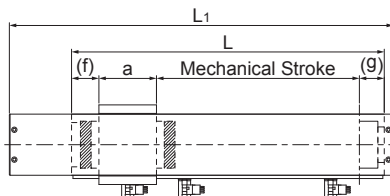

Block type A/C

Unit: mm

Model No.	Block type	Overall length L_1	Outer rail length L	Stroke ^{*1}	a	f	g
KR33	A	220	150	—	54	20	27.5
		270	200	85(98.5)			
		370	300	185(198.5)			
		470	400	285(298.5)			
		570	500	385(398.5)			
		670	600	485(498.5)			
	770	700	585(598.5)				
	C	220	150	60(74)	28.5	20	27.5
		270	200	110(124)			
		370	300	210(224)			
		470	400	310(324)			
		570	500	410(424)			
670		600	510(524)				
770	700	610(624)					
KR46	A	440.5	340	175(193)	81	29.5	36.5
		540.5	440	275(293)			
		640.5	540	375(393)			
		740.5	640	475(493)			
		840.5	740	575(593)			
		940.5	840	675(693)			
	1040.5	940	775(793)				
	C	440.5	340	205(230.5)	43.5	29.5	36.5
		540.5	440	305(330.5)			
		640.5	540	405(430.5)			
		740.5	640	505(530.5)			
		840.5	740	605(630.5)			
940.5		840	705(730.5)				
1040.5	940	805(830.5)					
KR55	A	1089	980	785(810)	95.2	31.4	43.4
		1189	1080	885(910)			
		1289	1180	985(1010)			
		1389	1280	1085(1110)			
		1489	1380	1185(1210)			
KR65	A	1098	980	775(794)	110	31.9	44.1
		1298	1180	975(994)			
		1498	1380	1175(1194)			
		1798	1680	1475(1494)			

Note) Block types B and D cannot be selected for QZB.

*1 The value in the parentheses represents the maximum stroke.

Code: QZB (without cover)
 Model No. : KR33/46/55/65
 Block type : A/C

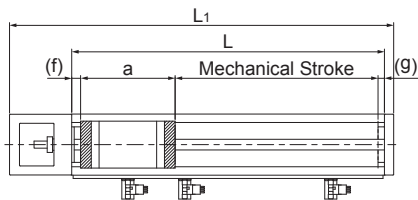

Block type A/C

Unit: mm

Model No.	Block type	Overall length L_1	Outer rail length L	Stroke ^{*1}	a^2	f	g
KR33	A	220	150	—	89 (85)	11	5.5
		270	200	85(98.5)			
		370	300	185(198.5)			
		470	400	285(298.5)			
		570	500	385(398.5)			
		670	600	485(498.5)			
	C	220	150	60(74)	63.5 (59.5)	11	5.5
		270	200	110(124)			
		370	300	210(224)			
		470	400	310(324)			
		570	500	410(424)			
		670	600	510(524)			
KR46	A	440.5	340	175(193)	125 (121)	17	9
		540.5	440	275(293)			
		640.5	540	375(393)			
		740.5	640	475(493)			
		840.5	740	575(593)			
		940.5	840	675(693)			
	C	440.5	340	205(230.5)	87.5 (83.5)	17	9
		540.5	440	305(330.5)			
		640.5	540	405(430.5)			
		740.5	640	505(530.5)			
		840.5	740	605(630.5)			
		940.5	840	705(730.5)			
KR55	A	1089	980	785(810)	144	15	11
		1189	1080	885(910)			
		1289	1180	985(1010)			
		1389	1280	1085(1110)			
		1489	1380	1185(1210)			
KR65	A	1098	980	775(794)	161	14.4	10.6
		1298	1180	975(994)			
		1498	1380	1175(1194)			
		1798	1680	1475(1494)			

Note) Block types B and D cannot be selected for QZB.

*1 The value in the parentheses represents the maximum stroke.

*2 () indicates the length of the inner block when calculating the allowed stroke range.

Code: QZAD (with cover)

Model No. : KR33/46/55/65

Block type : B/D

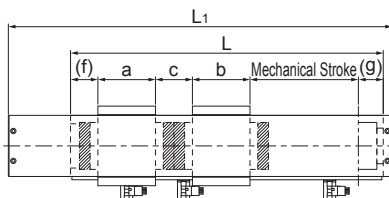

Block type B/D

Unit: mm

Model No.	Block type	Overall length L ₁	Outer rail length L	Stroke ^{*1,2}	a	b	C	f	g
KR33	B	220	150	—	54	54	22	33	27.5
		270	200	—					
		370	300	100(109.5)					
		470	400	200(209.5)					
		570	500	300(309.5)					
		670	600	400(409.5)					
		770	700	500(509.5)					
	D	220	150	—	28.5	28.5	22	33	27.5
		270	200	50(60.5)					
		370	300	150(160.5)					
		470	400	250(260.5)					
		570	500	350(360.5)					
		670	600	450(460.5)					
		770	700	550(560.5)					
KR46	B	440.5	340	—	81	81	29	44.5	36.5
		540.5	440	150(168)					
		640.5	540	250(268)					
		740.5	640	350(368)					
		840.5	740	450(468)					
		940.5	840	550(568)					
		1040.5	940	650(668)					
	D	440.5	340	120(143)	43.5	43.5	29	44.5	36.5
		540.5	440	220(243)					
		640.5	540	320(343)					
		740.5	640	420(443)					
		840.5	740	520(543)					
		940.5	840	620(643)					
		1040.5	940	720(743)					
KR55	B	1089	980	650(666)	95.2	95.2	32.8	47.4	43.4
		1189	1080	750(766)					
		1289	1180	850(866)					
		1389	1280	950(966)					
		1489	1380	1050(1066)					
KR65	B	1098	980	610(633)	110	110	35	47.9	44.1
		1298	1180	810(833)					
		1498	1380	1010(1033)					
		1798	1680	1310(1333)					

Note) Block types A and C cannot be selected for QZAD.

*1 The value in the parentheses represents the maximum stroke.

*2 The strokes for block types B and D are the values when in contact with the inner block.

Code: QZAD (without cover)
 Model No. : KR33/46/55/65
 Block type : B/D

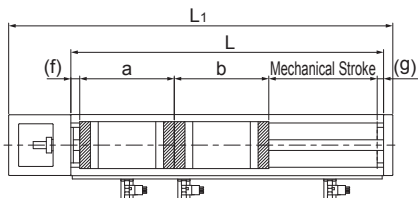

Block type B/D

Unit: mm

Model No.	Block type	Overall length L ₁	Outer rail length L	Stroke ^{*1,2}	a ^{*3}	b ^{*3}	f	g
KR33	B	220	150	—	89 (87)	89 (87)	11	5.5
		270	200	—				
		370	300	100(109.5)				
		470	400	200(209.5)				
		570	500	300(309.5)				
		670	600	400(409.5)				
		770	700	500(509.5)				
	D	220	150	—	63.5 (61.5)	63.5 (61.5)	11	5.5
		270	200	50(60.5)				
		370	300	150(160.5)				
		470	400	250(260.5)				
		570	500	350(360.5)				
		670	600	450(460.5)				
		770	700	550(560.5)				
KR46	B	440.5	340	—	125 (123)	125 (123)	17	9
		540.5	440	150(168)				
		640.5	540	250(268)				
		740.5	640	350(368)				
		840.5	740	450(468)				
		940.5	840	550(568)				
		1040.5	940	650(668)				
	D	440.5	340	120(143)	87.5 (85.5)	87.5 (85.5)	17	9
		540.5	440	220(243)				
		640.5	540	320(343)				
		740.5	640	420(443)				
		840.5	740	520(543)				
		940.5	840	620(643)				
		1040.5	940	720(743)				
KR55	B	1089	980	650(666)	144	144	15	11
		1189	1080	750(766)				
		1289	1180	850(866)				
		1389	1280	950(966)				
		1489	1380	1050(1066)				
KR65	B	1098	980	610(633)	161	161	14.4	10.6
		1298	1180	810(833)				
		1498	1380	1010(1033)				
		1798	1680	1310(1333)				

Note) Block types A and C cannot be selected for QZAD.

*1 The value in the parentheses represents the maximum stroke.

*2 The strokes for block types B and D are the values when in contact with the inner block.

*3 () indicates the length of the inner block when calculating the allowed stroke range.

Bellows

For model KR, bellows are available for contamination protection in addition to a cover.

[Model KR-A (with a Single Long Nut Block)]

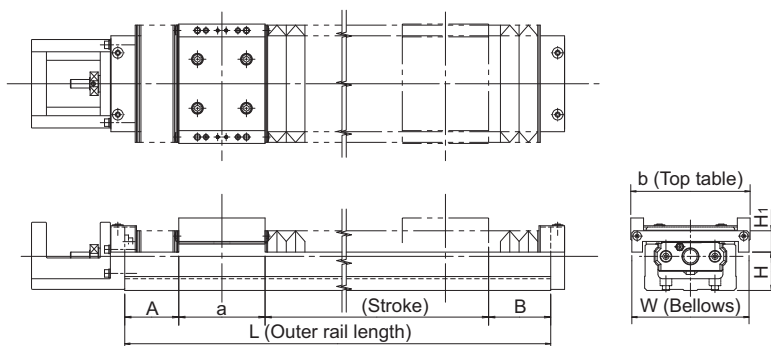

Unit: mm

Model No.	Stroke ¹	Outer rail length L	A	B	a	b	W	H	H ₁
KR15	15(22.2)	75	15.8	14	23	44	49	8	15.5
	30(37.2)	100	20.8	19					
	45(52.2)	125	25.8	24					
	60(67.2)	150	30.8	29					
	75(82.2)	175	35.8	34					
90(97.2)	200	40.8	39						
KR20	20(30.8)	100	18.8	17.2	33.2	52	60	10	20
	55(67.8)	150	25.3	23.7					
	80(93.6)	200	37	36.2					
KR26	50(61.3)	150	23.7	17.6	47.4	62	74	18	20
	80(91.6)	200	32.8	28.2					
	110(125.6)	250	40.8	36.2					
	160(175.6)	300	40.8	36.2					
KR30H	30(42)	150	28.5	25.5	54	80	80	21.5	17.5
	60(72)	200	38.5	35.5					
	130(142)	300	53.5	50.5					
	200(212)	400	68.5	65.5					
	270(282)	500	83.5	80.5					
	340(352)	600	98.5	95.5					
KR33	30(42)	150	28.4	25.6	54	86	84	24.5	20
	70(82)	200	33.4	30.6					
	150(162)	300	43.4	40.6					
	220(232)	400	58.4	55.6					
	300(312)	500	68.4	65.6					
	370(382)	600	83.4	80.6					
	450(462)	700	93.4	90.6					

Model No.	Stroke ^{*1}	Outer rail length L	A	B	a	b	W	H	H _i
KR45H	160(177)	340	41.1	40.9	81	104	104	28	28
	240(255)	440	52.1	51.9					
	320(339)	540	60.1	59.9					
	400(423)	640	68.1	67.9					
	470(491)	740	84.1	83.9					
	550(575)	840	92.1	91.9					
KR46	640(659)	940	100.1	99.9	81	112	110	36	20
	140(155)	340	52.9	51.1					
	210(225)	440	67.9	66.1					
	290(305)	540	77.9	76.1					
	360(375)	640	92.9	91.1					
	440(455)	740	102.9	101.1					
KR55	510(525)	840	117.9	116.1	95.2	124	154	37	40
	590(605)	940	127.9	126.1					
	700(719.6)	980	84.6	80.6					
	790(809.6)	1080	89.6	85.6					
	870(889.6)	1180	99.6	95.6					
KR65	960(979.6)	1280	104.6	100.6	110	170	184	40	47
	1050(1069.6)	1380	109.6	105.6					
	680(703.2)	980	85.1	81.7					
	860(883.2)	1180	95.1	91.7					
	1030(1053.2)	1380	110.1	106.7					
	1290(1313.2)	1680	130.1	126.7					

*1 The value in the parentheses represents the maximum stroke.

*2 The bellows for KR55 and KR65 are only suitable for horizontal orientation. If the bellows is to be used in other orientations (vertical or wall-mounted), contact THK.

[Model KR-B (with Two Long Nut Blocks)]

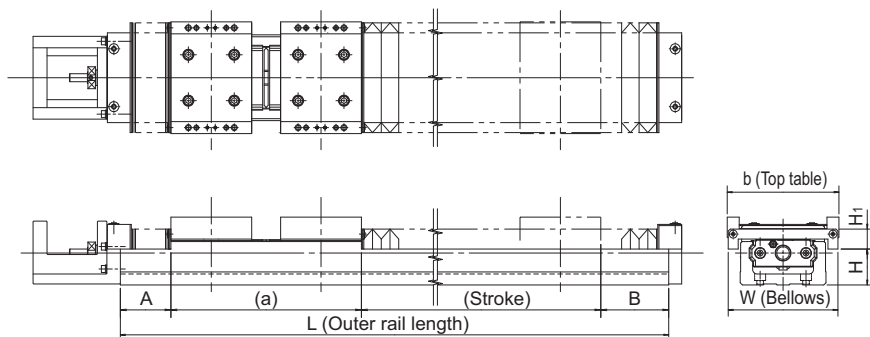

Unit: mm

Model No.	Stroke ^{1,2}	Outer rail length L	A	B	a	b	W	H	H ₁
KR15	20(29.2)	125	20.8	19	56	44	49	8	15.5
	35(44.2)	150	25.8	24					
	50(59.2)	175	30.8	29					
	65(74.2)	200	35.8	34					
KR20	25(34.8)	150	18.8	17.2	79.2	52	60	10	20
	60(71.8)	200	25.3	23.7					
KR26	35(47.3)	200	23.7	17.6	111.4	62	74	18	20
	65(77.6)	250	32.8	28.2					
	115(127.6)	300	32.8	28.2					
KR30H	85(97.6)	300	38.5	35.5	128.4	80	80	21.5	17.5
	155(167.6)	400	53.5	50.5					
	225(237.6)	500	68.5	65.5					
	295(307.6)	600	83.5	80.5					
KR33	80(96)	300	38.4	35.6	130	86	84	24.5	20
	160(176)	400	48.4	45.6					
	240(256)	500	58.4	55.6					
	310(326)	600	73.4	70.6					
KR45H	390(406)	700	83.4	80.6	189	104	104	28	28
	80(95)	340	28.1	27.9					
	155(170.5)	440	41.1	39.4					
	230(247)	540	52.1	51.9					
	310(331)	640	60.1	59.9					
	400(415)	740	68.1	67.9					
KR46	465(483)	840	84.1	83.9	191	112	110	36	20
	550(567)	940	92.1	91.9					
	60(75)	340	37.9	36.1					
	130(145)	440	52.9	51.1					
	210(225)	540	62.9	61.1					
	280(295)	640	77.9	76.1					
	360(375)	740	87.9	86.1					
430(445)	840	102.9	101.1						
510(525)	940	112.9	111.1						

Model No.	Stroke ^{*1,2}	Outer rail length L	A	B	a	b	W	H	H _i
KR55	590(612)	980	74.6	70.6	222.8	124	154	37	40
	670(692)	1080	84.6	80.6					
	760(782)	1180	89.6	85.6					
	850(872)	1280	94.6	90.6					
KR65	930(952)	1380	104.6	100.6	254.6	170	184	40	47
	550(578.6)	980	75.1	71.7					
	720(748.6)	1180	90.1	86.7					
	900(928.6)	1380	100.1	96.7					
	1160(1188.6)	1680	120.1	116.7					

*1 The strokes in the table are values when the blocks are in close contact with each other.

*2 The value in the parentheses represents the maximum stroke.

*3 The bellows for KR55 and KR65 are only suitable for horizontal orientation. If the bellows is to be used in other orientations (vertical or wall-mounted), contact THK.

Note) The bellows cannot be attached between the top tables.

[Model KR-C (with a Single Short Nut Block)]

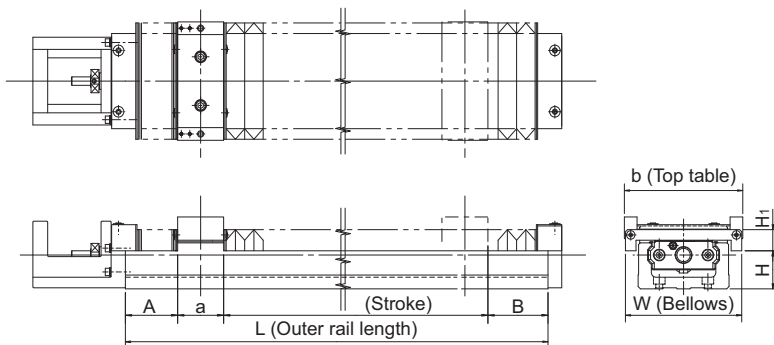

Unit: mm

Model No.	Stroke*	Outer rail length L	A	B	a	b	W	H	H ₁
KR30H	45(57.5)	150	33.5	30.5	28.5	80	80	21.5	17.5
	85(97.5)	200	38.5	35.5					
	155(167.5)	300	53.5	50.5					
	225(237.5)	400	68.5	65.5					
	295(307.5)	500	83.5	80.5					
365(377.5)	600	98.5	95.5						
KR33	55(67.5)	150	28.4	25.6	28.5	86	84	24.5	20
	95(107.5)	200	33.4	30.6					
	165(177.5)	300	48.4	45.6					
	245(257.5)	400	58.4	55.6					
	315(327.5)	500	73.4	70.6					
	395(407.5)	600	83.4	80.6					
465(477.5)	700	98.4	95.6						
KR45H	190(208.5)	340	44.1	43.9	43.5	104	104	28	28
	275(292.5)	440	52.1	51.9					
	340(360.5)	540	68.1	67.9					
	425(444.5)	640	76.1	75.9					
	510(528.5)	740	84.1	83.9					
	580(596.5)	840	100.1	99.9					
660(680.5)	940	108.1	107.9						
KR46	170(182.5)	340	57.9	56.1	43.5	112	110	36	20
	240(252.5)	440	72.9	71.1					
	320(332.5)	540	82.9	81.1					
	390(402.5)	640	97.9	96.1					
	470(482.5)	740	107.9	106.1					
	540(552.5)	840	122.9	121.1					
620(632.5)	940	132.9	131.1						

*The value in the parentheses represents the maximum stroke.

[Model KR-D (with Two Short Nut Blocks)]

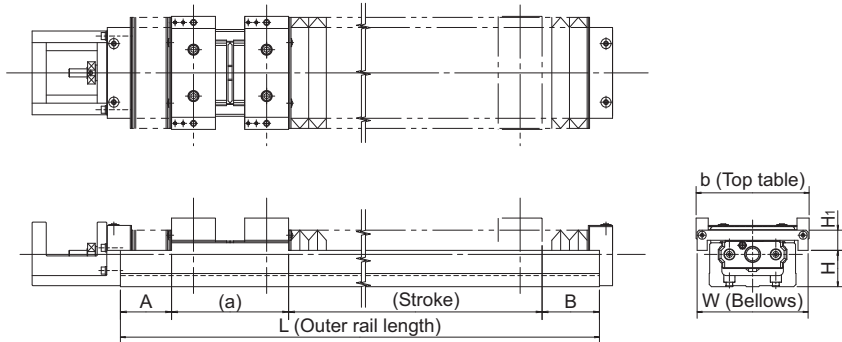

Unit: mm

Model No.	Stroke ^{*1,2}	Outer rail length L	A	B	a	b	W	H	H ₁
KR30H	15(28.6)	150	23.5	20.5	77.4	80	80	21.5	17.5
	45(58.6)	200	33.5	30.5					
	115(128.6)	300	48.5	45.5					
	185(198.6)	400	63.5	60.5					
	255(268.6)	500	78.5	75.5					
325(338.6)	600	93.5	90.5						
KR33	55(67)	200	28.4	25.6	79	86	84	24.5	20
	125(137)	300	43.4	40.6					
	205(217)	400	53.4	50.6					
	275(287)	500	68.4	65.6					
	355(367)	600	78.4	75.6					
425(437)	700	93.4	90.6						
KR45H	140(154)	340	36.1	35.9	114	104	104	28	28
	220(238)	440	44.1	43.9					
	290(306)	540	60.1	59.9					
	370(390)	640	68.1	67.9					
	455(474)	740	76.1	75.9					
	525(542)	840	92.1	91.9					
605(626)	940	100.1	99.9						
KR46	110(130)	340	47.9	46.1	116	112	110	36	20
	180(200)	440	62.9	61.1					
	260(280)	540	72.9	71.1					
	330(350)	640	87.9	86.1					
	410(430)	740	97.9	96.1					
	480(500)	840	112.9	111.1					
560(580)	940	122.9	121.1						

*1 The strokes in the table are values when the blocks are in close contact with each other.

*2 The value in the parentheses represents the maximum stroke.

Note) The bellows cannot be attached between the top tables.

Sensor

Optional photo sensors and proximity sensors are available for KR models.

[Example of Installation]

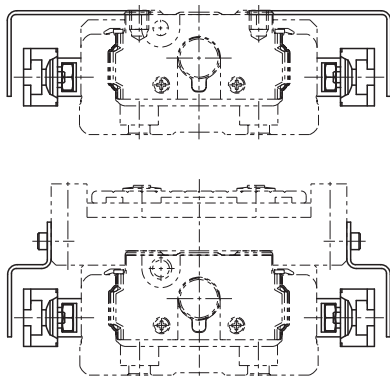

Table14 With/without a sensor

Symbol	Description	Type	Accessory ^{*1}
0	None	—	—
1	With sensor rail	—	Mounting screws, sensor rail
2	Photo Sensor ^{*2} [3 units]	EE-SX671 (Omron Corp.)	Mounting screw/nut, detecting plate, sensor rail, mounting plate, connector (EE-1001)
6	Photo Sensor ^{*2} [3 units]	EE-SX674 (Omron Corp.)	Mounting screw/nut, detecting plate, sensor rail, mounting plate, connector (EE-1001)
7	Proximity Sensor N.O. contact [3 units]	APM-D3A1-001 (Azbil Corp.)	Mounting screw/nut, detecting plate, sensor rail
B	Proximity Sensor N.C. contact [3 units]	APM-D3B1-003 (Azbil Corp.)	Mounting screw/nut, detecting plate, sensor rail
E	Proximity Sensor N.O. contact [1 unit] N.C. contact [2 units]	APM-D3A1-001 APM-D3B1-003 (Azbil Corp.)	Mounting screw/nut, detecting plate, sensor rail
H	Proximity Sensor N.O. contact [3 units]	GX-F12A (Panasonic Industrial Devices SUNX Co., Ltd.)	Mounting screw/nut, detecting plate, sensor rail
L	Proximity Sensor N.C. contact [3 units]	GX-F12B (Panasonic Industrial Devices SUNX Co., Ltd.)	Mounting screw/nut, detecting plate, sensor rail
J	Proximity Sensor N.O. contact [1 unit] N.C. contact [2 units]	GX-F12A GX-F12B (Panasonic Industrial Devices SUNX Co., Ltd.)	Mounting screw/nut, detecting plate, sensor rail
M	Proximity Sensor N.O. contact [1 unit] N.C. contact [2 units]	GX-F12A-P GX-F12B-P (Panasonic Industrial Devices SUNX Co., Ltd.)	Mounting screw/nut, detecting plate, sensor rail

N.O. contact: normally open contact

N.C. contact: normally closed contact

*1 If the stroke is less than 70 mm, 2 sensor flags and 2 sensor rails will be included. KR15, 20 and 26 ship with sensor rails already installed.

*2 The photo-sensors can be switched between ON when lit and ON when unlit.

[Proximity Sensor]

APM-D3A1-001 (Azbil Corp.)	3 units	GX-F12B (Panasonic Industrial Devices SUNX Co., Ltd.)	3 units
APM-D3B1-003 (Azbil Corp.)	3 units	GX-F12A-P (Panasonic Industrial Devices SUNX Co., Ltd.)	3 units
GX-F12A (Panasonic Industrial Devices SUNX Co., Ltd.)	3 units	GX-F12B-P (Panasonic Industrial Devices SUNX Co., Ltd.)	3 units

● Proximity Sensor: APM-D3A1-001 APM-D3B1-003 (Azbil Corp.)

Unit: mm

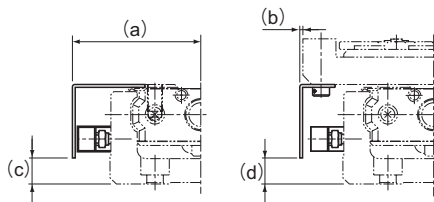

Model No.	a	b	c	d
KR15	27.8	5.8	1.4	1.4
KR20	32.5	6.6	6	6
KR26	37	6.4	8	8
KR30H	43.3	3.3	8.8	9
KR33	42.5	-0.6	8.8	9
KR45H	53.2	1.2	14	14
KR46	55.4	-0.6	21.8	22
KR55	62.4	0.4	22	22
KR65	77.4	-7.6	25.1	25

● Proximity sensor GX-F12A GX-F12B GX-F12A-P
GX-F12B-P (Panasonic Industrial Devices SUNX Co., Ltd.)

Unit: mm

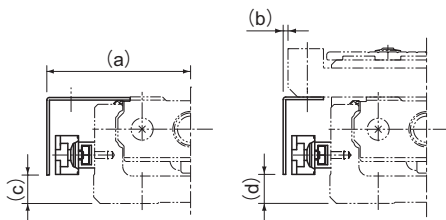

Model No.	a	b	c	d
KR20	34	8.1	3.6	4
KR26	38.5	7.9	6	6
KR30H	45	5	8.8	9
KR33	44.5	1.5	8.8	9
KR45H	54.8	2.8	13.8	14
KR46	57.5	1.5	21.8	22
KR55	64.5	2.5	22	22
KR65	79	-6	25.1	25

[Photo Sensor]

EE-SX671 (Omron Corp.) 3 units

EE-SX674 (Omron Corp.) 3 units

Connector EE-1001 (Omron Corp.) 3 units

Note) The connector is an appended article.

● **Photo Sensor: EE-SX671 (Omron Corp.)**

Unit: mm

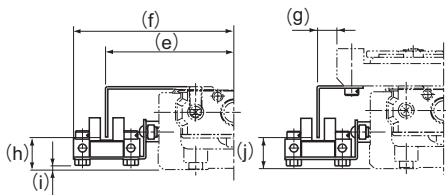

Model No.	e	f	g	h	i	j
KR20	41.3	53.8	15	9.4	0.9	9.5
KR26	46	58.7	14.9	11.4	2.9	11.5
KR30H	51.3	63.9	11.3	13.8	1.4	13.5
KR33	50.8	63.7	7.7	12.8	2.2	13
KR45H	61.2	73.8	9.3	18.3	6.4	18.5
KR46	63.6	76.6	7.7	25.8	15.2	26
KR55	70.7	83.5	8.6	24.5	13.6	25
KR65	85.5	98.5	0.6	28.1	16.6	28

● **Photo Sensor: EE-SX674 (Omron Corp.)**

Unit: mm

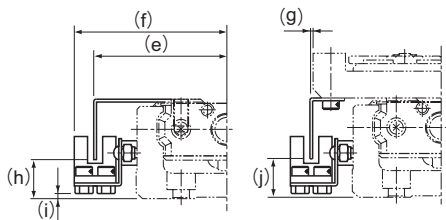

Model No.	e	f	g	h	i	j
KR20	38.3	44.8	12.5	10.9	0.6	11
KR26	43.5	49.7	12.5	12.9	2.6	13
KR30H	46.2	52.4	6.3	13.8	1.1	14
KR33	44.5	50.7	1.5	12.8	1.7	13
KR45H	56.2	62.3	4.2	19	6.1	19
KR46	57.5	63.6	1.5	25.8	14.1	26
KR55	63.5	70.5	1.5	24.5	13.1	24
KR65	79	85.5	-6	28.6	16.1	28

[Sensor Rail]

The sensor rail can be attached alone.

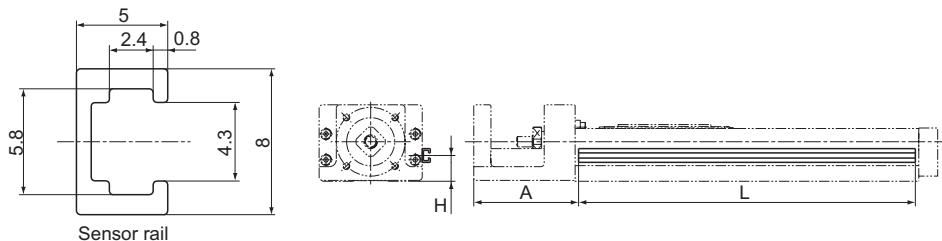

Sensor rail

Unit: mm

Model No.	Stroke*	Outer rail length	H	A	L
KR15	25	75	5.5	37.5	88
	50	100			113
	75	125			138
	100	150			163
	125	175			188
	150	200			213
KR20	30	100	10	43	111
	80	150			161
	130	200			211
KR26	60	150	12	54	161
	110	200			211
	160	250			261
	210	300			311
KR30H	50	150	14	61	146
	100	200			196
	200	300			296
	300	400			396
	400	500			496
	500	600			596
KR33	50	150	15	61	146
	100	200			196
	200	300			296
	300	400			396
	400	500			496
	500	600			596
	600	700			696
KR45H	200	340	19	90	336
	300	440			436
	400	540			536
	500	640			636
	600	740			736
	700	840			836
	800	940			936

*Indicates stroke length when one long-type inner block is incorporated.

Unit: mm

Model No.	Stroke*	Outer rail length	H	A	L
KR46	190	340	28	89.5	336
	290	440			436
	390	540			536
	490	640			636
	590	740			736
	690	840			836
	790	940			936
KR55	800	980	27	96	976
	900	1080			1076
	1000	1180			1176
	1100	1280			1276
	1200	1380			1376
KR65	790	980	30	102	976
	990	1180			1176
	1190	1380			1376
	1490	1680			1676

Intermediate Flange (Direct Coupling)

[Motors Used and Applicable Intermediate Flanges for Model KR]

Several types of intermediate flanges for mounting motors are available for model KR. Specify an intermediate flange that matches the motor used.

Each intermediate flange is made of steel and provided with THK AP-C treatment, a surface treatment that provides excellent corrosion resistance.

Table15 Motors Used and Corresponding Housing A and Intermediate Flanges

Motor type		Rated output	Flange size	KR										
				KR15	KR20	KR26	KR30H	KR33	KR45H	KR46	KR55	KR65		
AC servo motor Yaskawa Electric	Σ -V mini	SGMMV-A1	10 W	□25	AN	AN	AN	—	—	—	—	—	—	—
		SGMMV-A2	20 W		AN	AN	AN	—	—	—	—	—	—	—
		SGMMV-A3	30 W		AN	AN	AN	—	—	—	—	—	—	—
	Σ -V	SGMJV-A5	50 W	□40	—	AQ	AQ	AQ	AQ	—	—	—	—	—
					—	AQ	AQ	AQ	AQ	—	—	—	—	—
		SGMJV-01	100 W		—	—	—	AQ	AQ	—	—	—	—	—
					—	—	—	AQ	AQ	—	—	—	—	
					—	—	—	AQ	AQ	—	—	—	—	
		SGMJV-C2	150 W		—	—	—	AQ	AQ	—	—	—	—	—
					—	—	—	—	—	—	—	—	—	
					—	—	—	—	—	—	—	—	—	
		SGMJV-02	200 W		—	—	—	—	—	—	A0	40	A0	AV
					—	—	—	—	—	—	A0	40	A0	AV
					—	—	—	—	—	—	A0	40	A0	AV
		SGMJV-04	400 W		—	—	—	—	—	—	A0	40	A0	AV
					—	—	—	—	—	—	A0	40	A0	AV
					—	—	—	—	—	—	A0	40	A0	AV
		SGMJV-06	600 W		—	—	—	—	—	—	A0	40	A0	AV
	—			—	—	—	—	—	—	—	AZ	AZ		
	—			—	—	—	—	—	—	—	AZ	AZ		
	Σ -7	SGM7J-A5	50 W	□40	—	AQ	AQ	AQ	AQ	—	—	—	—	
					—	AQ	AQ	AQ	AQ	—	—	—	—	
		SGM7J-01	100 W		—	—	—	AQ	AQ	—	—	—	—	
					—	—	—	AQ	AQ	—	—	—	—	
					—	—	—	AQ	AQ	—	—	—	—	
		SGM7J-C2	150 W		—	—	—	AQ	AQ	—	—	—	—	
					—	—	—	—	—	—	—	—	—	
					—	—	—	—	—	—	—	—	—	
SGM7J-02		200 W	—		—	—	—	—	—	A0	40	A0	AV	
			—		—	—	—	—	—	A0	40	A0	AV	
			—		—	—	—	—	—	A0	40	A0	AV	
SGM7J-04		400 W	—		—	—	—	—	—	A0	40	A0	AV	
	—		—	—	—	—	—	A0	40	A0	AV			
	—		—	—	—	—	—	A0	40	A0	AV			
SGM7J-06	600 W	—	—	—	—	—	—	A0	40	A0	AV			
		—	—	—	—	—	—	—	—	AZ	AZ			
		—	—	—	—	—	—	—	—	AZ	AZ			
SGM7J-08	750 W	—	—	—	—	—	—	—	—	AZ	AZ			
		—	—	—	—	—	—	—	—	AZ	AZ			

Motor type		Rated output	Flange size	KR														
				KR15	KR20	KR26	KR30H	KR33	KR45H	KR46	KR55	KR65						
AC servo motor	Yaskawa Electric	Σ-X	50 W	□40	—	AQ	AQ	AQ	AQ	—	—	—	—	—	—	—	—	
					—	AQ	AQ	AQ	AQ	—	—	—	—	—	—	—	—	
					—	—	—	AQ	AQ	—	—	—	—	—	—	—	—	
			100 W		—	—	—	AQ	AQ	—	—	—	—	—	—	—	—	
					—	—	—	AQ	AQ	—	—	—	—	—	—	—	—	
					—	—	—	AQ	AQ	—	—	—	—	—	—	—	—	
		150 W	—	—	—	AQ	AQ	—	—	—	—	—	—	—	—			
			200 W	—	—	—	—	—	—	A0	40	A0	A0	AV	—	—	—	—
				—	—	—	—	—	—	A0	40	A0	A0	AV	—	—	—	—
		—		—	—	—	—	—	A0	40	A0	A0	AV	—	—	—	—	
		400 W	—	—	—	—	—	—	A0	40	A0	A0	AV	—	—	—	—	
			—	—	—	—	—	—	A0	40	A0	A0	AV	—	—	—	—	
			—	—	—	—	—	—	A0	40	A0	A0	AV	—	—	—	—	
		600 W	—	—	—	—	—	—	A0	40	A0	A0	AV	—	—	—	—	
	—		—	—	—	—	—	A0	40	A0	A0	AV	—	—	—	—		
	—		—	—	—	—	—	A0	40	A0	A0	AV	—	—	—	—		
	750 W	—	—	—	—	—	—	—	—	—	AZ	AZ	—	—	—	—		
		—	—	—	—	—	—	—	—	—	AZ	AZ	—	—	—	—		
		—	—	—	—	—	—	—	—	—	AZ	AZ	—	—	—	—		
	Mitsubishi Electric	MELSERVO	J4	10 W	□25	AN	AN	AN	—	—	—	—	—	—	—	—	—	—
						AN	AN	AN	—	—	—	—	—	—	—	—	—	—
						AN	AN	AN	—	—	—	—	—	—	—	—	—	—
			50 W	—	AQ	AQ	AQ	AQ	—	—	—	—	—	—	—	—		
				—	AQ	AQ	AQ	AQ	—	—	—	—	—	—	—	—		
				—	—	—	AQ	AQ	—	—	—	—	—	—	—	—		
			100 W	—	—	—	AQ	AQ	—	—	—	—	—	—	—	—		
				—	—	—	AQ	AQ	—	—	—	—	—	—	—	—		
				—	—	—	AQ	AQ	—	—	—	—	—	—	—	—		
			200 W	—	—	—	—	—	—	A0	40	A0	A0	AV	—	—	—	—
		—		—	—	—	—	—	A0	40	A0	A0	AV	—	—	—	—	
—		—		—	—	—	—	A0	40	A0	A0	AV	—	—	—	—		
400 W		—	—	—	—	—	—	A0	40	A0	A0	AV	—	—	—	—		
		—	—	—	—	—	—	A0	40	A0	A0	AV	—	—	—	—		
		—	—	—	—	—	—	A0	40	A0	A0	AV	—	—	—	—		
750 W		—	—	—	—	—	—	—	—	—	AZ	AZ	—	—	—	—		
		—	—	—	—	—	—	—	—	—	AZ	AZ	—	—	—	—		
		—	—	—	—	—	—	—	—	—	AZ	AZ	—	—	—	—		
J5		50 W	—	AQ	AQ	AQ	AQ	—	—	—	—	—	—	—	—	—		
			—	—	—	AQ	AQ	—	—	—	—	—	—	—	—			
	—		—	—	—	—	—	A0	40	A0	A0	AV	—	—	—	—		
	100 W	—	—	—	—	—	—	A0	40	A0	A0	AV	—	—	—	—		
		—	—	—	—	—	—	A0	40	A0	A0	AV	—	—	—	—		
		—	—	—	—	—	—	A0	40	A0	A0	AV	—	—	—	—		
	200 W	—	—	—	—	—	—	—	—	—	AZ	AZ	—	—	—	—		
		—	—	—	—	—	—	—	—	—	AZ	AZ	—	—	—	—		
		—	—	—	—	—	—	—	—	—	AZ	AZ	—	—	—	—		
	400 W	—	—	—	—	—	—	—	—	—	AZ	AZ	—	—	—	—		
—		—	—	—	—	—	—	—	—	AZ	AZ	—	—	—	—			
—		—	—	—	—	—	—	—	—	AZ	AZ	—	—	—	—			
750 W	—	—	—	—	—	—	—	—	—	AZ	AZ	—	—	—	—			
	—	—	—	—	—	—	—	—	—	AZ	AZ	—	—	—	—			
	—	—	—	—	—	—	—	—	—	AZ	AZ	—	—	—	—			
JN	50 W	—	AQ	AQ	AQ	AQ	—	—	—	—	—	—	—	—	—			
		—	—	—	AQ	AQ	—	—	—	—	—	—	—	—				
		—	—	—	—	—	—	A0	40	A0	A0	AV	—	—	—	—		
	100 W	—	—	—	—	—	—	A0	40	A0	A0	AV	—	—	—	—		
		—	—	—	—	—	—	A0	40	A0	A0	AV	—	—	—	—		
		—	—	—	—	—	—	A0	40	A0	A0	AV	—	—	—	—		
	200 W	—	—	—	—	—	—	—	—	—	AZ	AZ	—	—	—	—		
		—	—	—	—	—	—	—	—	—	AZ	AZ	—	—	—	—		
		—	—	—	—	—	—	—	—	—	AZ	AZ	—	—	—	—		
	400 W	—	—	—	—	—	—	—	—	—	AZ	AZ	—	—	—	—		
—		—	—	—	—	—	—	—	—	AZ	AZ	—	—	—	—			
—		—	—	—	—	—	—	—	—	AZ	AZ	—	—	—	—			
Tamegawa Seiki Co., Ltd.	TBL-i II	TS4602	50 W	□40	—	AQ	AQ	AQ	AQ	—	—	—	—	—	—	—	—	
		TS4603	100 W		—	—	—	AQ	AQ	—	—	—	—	—	—	—	—	
		TS4604	150 W		—	—	—	AQ	AQ	—	—	—	—	—	—	—	—	
		TS4607	200 W		—	—	—	—	—	—	A0	40	A0	AV	—	—	—	—
		TS4609	400 W		—	—	—	—	—	—	A0	40	A0	AV	—	—	—	—
	TS4614	750 W	□80	—	—	—	—	—	—	—	AZ	AZ	—	—	—	—		
	TBL-iIV	TSM3102	50 W	□40	—	AQ	AQ	AQ	AQ	—	—	—	—	—	—	—	—	
		TSM3104	100 W		—	—	—	AQ	AQ	—	—	—	—	—	—	—	—	
		TSM3202	200 W		—	—	—	—	—	—	A0	40	A0	AV	—	—	—	—
		TSM3204	400 W		□60	—	—	—	—	—	—	A0	40	A0	AV	—	—	—
TSM3303		600 W	□80		—	—	—	—	—	—	—	AZ	AZ	—	—	—	—	
TSM3304	750 W	□80	—	—	—	—	—	—	—	AZ	AZ	—	—	—	—			

Motor type				Rated output	Flange size	KR										
						KR15	KR20	KR26	KR30H	KR33	KR45H	KR46	KR55	KR65		
AC servo motor	Panasonic Corp.	MINAS	A5	MSMD5A	50 W	□38	—	AP	AP	AP	AP	—	—	—	—	
				MSME5A			—	AP	AP	AP	AP	—	—	—	—	
				MSMD01	100 W		—	—	—	AP	AP	—	—	—	—	
			MSME01	—			—	—	AP	AP	—	—	—	—		
			MSMD02	200 W	□60		—	—	—	—	—	—	AY	30	—	—
			MSME02				—	—	—	—	—	AY	30	—	—	
			MSMD04	400 W		—	—	—	—	—	AY	30	—	—		
			MSME04			—	—	—	—	AY	30	—	—			
			MSMD08	750 W		□80	—	—	—	—	—	—	—	A5	A5	
		MSME08	—				—	—	—	—	—	A5	A5			
		MSMF5A	50 W	□38	—		AP	AP	AP	AP	—	—	—	—		
		MHMF5A		□40	—		AQ	AQ	AQ	AQ	—	—	—	—		
		MSMF01	100 W	□38	—		—	—	AP	AP	—	—	—	—		
		MHMF01		□40	—		—	—	AQ	AQ	—	—	—	—		
		MSMF02	200 W	□60	—	—	—	—	—	AY	30	—	—			
		MHMF02			—	—	—	—	—	AY	30	—	—			
		MSMF04	400 W		—	—	—	—	—	AY	30	—	—			
		MHMF04			—	—	—	—	—	AY	30	—	—			
	MSMF08	750 W	□80		—	—	—	—	—	—	—	A5	A5			
	MHMF08				—	—	—	—	—	—	A5	A5				
	Keyence Corporation	SV		SV-M005	50 W	□40	—	AQ	AQ	AQ	AQ	—	—	—	—	
				SV-M010	100 W		—	—	—	AQ	AQ	—	—	—	—	
				SV-M020	200 W	□60	—	—	—	—	A0	40	A0	AV		
				SV-M040	400 W		—	—	—	—	A0	40	A0	AV		
SV-M075			750 W	□80	—	—	—	—	—	—	AZ	AZ				
SV2			SV2-M005	50 W	□40	—	AQ	AQ	AQ	AQ	—	—	—	—		
		SV2-M010	100 W	—		—	—	AQ	AQ	—	—	—	—			
		SV2-M020	200 W	□60	—	—	—	—	A0	40	A0	AV				
		SV2-M040	400 W		—	—	—	—	A0	40	A0	AV				
		SV2-M075	750 W	□80	—	—	—	—	—	—	AZ	AZ				
		SANYO DENKI	SANMOTION R	R2□A04005	50 W	□40	—	AQ	AQ	AQ	AQ	—	—	—	—	
R2EA04008				80 W	—		—	—	AQ	AQ	—	—	—	—		
R2□A04010	100 W			□60	—	—	—	AQ	AQ	—	—	—	—			
R2□A06020	200 W				—	—	—	—	A0	40	A0	AV				
R2AA06040	400 W			□80	—	—	—	—	A0	40	A0	AV				
R2AA08075	750 W				—	—	—	—	—	—	AZ	AZ				
Omron	OMINUC G5	R88M-K05030	50 W	□40	—	AQ	AQ	AQ	AQ	—	—	—	—			
		R88M-K10030	100 W		—	—	—	AQ	AQ	—	—	—	—			
		R88M-K20030	200 W	□60	—	—	—	—	AY	30	—	—				
		R88M-K40030	400 W		—	—	—	—	AY	30	—	—				
		R88M-K75030	750 W	□80	—	—	—	—	—	—	A5	A5				
	1S	R88M-1M10030	100 W	□40	—	—	—	AQ	AQ	—	—	—	—			
		R88M-1M20030	200 W	□60	—	—	—	—	AY	30	—	—				
		R88M-1M40030	400 W		—	—	—	—	AY	30	—	—				
		R88M-1M75030	750 W	□80	—	—	—	—	—	—	A5	A5				
		Fanuc	β is series	βis0.2/5000	50 W	□40	—	AQ	AQ	AQ	AQ	—	—	—	—	
βis0.3/5000	100 W			—	—		—	AQ	AQ	—	—	—	—			

		Motor type	Flange size	KR										
				KR15	KR20	KR26	KR30H	KR33	KR45H	KR46	KR55	KR65		
Stepping motor	Oriental Motor	α Step	AZ2 *, AR2 *	□28	AS	AS	AS	—	—	—	—	—	—	
			AZ4 *, AR4 *	□42	—	AR	AR	AR	AR	—	—	—	—	
			AZM48	□42	—	AR	AR	AR	AR	—	—	—	—	
			AZ6 *, AR6 *	□60	—	—	—	AU	AU	AU	10	—	—	
			AZ9 *, AR9 *	□85	—	—	—	—	—	—	—	A6	A6	
		5 phase	CRK	CRK52 *	□28	AS	AS	AS	—	—	—	—	—	—
				CRK54 *	□42	—	AR	AR	AR	AR	—	—	—	—
				CRK56 *	□60	—	—	—	AU	AU	AU	10	—	—
			RK II	RKS54 *	□42	—	AR	AR	AR	AR	—	—	—	—
				RKS56 *	□60	—	—	—	AU	AU	AU	10	—	—
	2 phase	PKP	RKS59 *	□85	—	—	—	—	—	—	—	A6	A6	
			PKP52 *	□28	AS	AS	AS	—	—	—	—	—	—	
		PKP/CVD	PKP54 *	□42	—	AR	AR	AR	AR	—	—	—	—	
			PKP56 *	□56.4	—	—	—	AT	AT	—	—	—	—	
			PKP56 *	□60	—	—	—	AU	AU	AU	10	—	—	
			PKP22 *	□28	AS	AS	AS	—	—	—	—	—	—	
	SANYO DENKI	PB	PKP24 *	□42	—	AR	AR	AR	AR	—	—	—	—	
			PKP26 *	□56.4	—	—	—	AT	AT	—	—	—	—	
			PBDM28 *	□28	AS	AS	AS	—	—	—	—	—	—	
		5 phase	PBDM423, PBA ** 423	□42	—	AR	AR	AR	AR	—	—	—	—	
			PBDM60 *, PBA ** 60 *	□60	—	—	—	AU	AU	AU	10	—	—	
			FAF/FDF52 *	□28	AS	AS	AS	—	—	—	—	—	—	
			FAF54 */FDF54 */ FA511M42/FB511M42	□42	—	AR	AR	AR	AR	—	—	—	—	
			FAM56 */FDM56 */ FA512M60/FB512M60	□60	—	—	—	AU	AU	AU	10	—	—	
		2 phase	D * 14S28 *	□28	AS	AS	AS	—	—	—	—	—	—	
			DB14H52 *	□42	—	AR	AR	AR	AR	—	—	—	—	
DU15H52 *	—		AR		AR	AR	AR	—	—	—	—			
D * 16H71 *	□56		—	—	—	AT	AT	—	—	—	—			
DB16H78 *	□60		—	—	—	AU	AU	AU	10	—	—			
Keyence Corporation	2 phase	QS-M28	□28	AS	AS	AS	—	—	—	—	—	—		
		QS-M42	□42	—	AR	AR	AR	AR	—	—	—	—		
		QS-M60	□60	—	—	—	AU	AU	AU	10	—	—		

Note 1) The symbols in the table indicate the housing A and intermediate flange.

Note 2) For the motor coupling, contact THK.

Note 3) The motor types in the table represent only some of the types available. For details regarding different types, please see the catalog from each respective motor manufacturer.

Note 4) Model KR15 has a limit in input torque. The permissible input torque for model KR1501 is 0.051 N·m at a maximum, and that for model KR1502 is 0.103 N·m at a maximum. If the maximum torque of the motor mounted to model KR15 exceeds the permissible input torque, take a safety measure such as setting a torque limit.

Intermediate Flange (Motor Wrap)

[Motors Used and Applicable Intermediate Flanges for Model KR]

Several types of intermediate flanges for mounting motors are available.

In model coding 7, "With/without motor," specify an intermediate flange that matches the motor used: R1, R2, R3, R4, R5, or R6.

Symbol Coding

Wrap symbol ①	Intermediate flange ②	Motor shaft diameter (mm) ③	Motor shaft securing method ④
W	Q	08	D
W	Please refer to "Motors Used and Corresponding Housing A and Intermediate Flanges" below.	Please specify a motor shaft diameter. (Please refer to "Motors Used and Corresponding Housing A and Intermediate Flanges" below.)	K : Key D : Flat M : Friction fastener

Motor shaft securing method

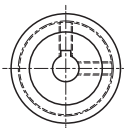

Key

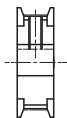

Flat

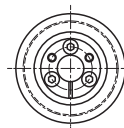
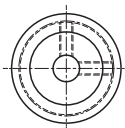

Friction fastener

Table16 Motors Used and Corresponding Housing A and Intermediate Flanges

Motor type		Rated output	Flange size	KR											
				KR15	KR20	KR26	KR30H	KR33	KR45H	KR46	KR55	KR65			
AC servo motor Yaskawa Electric	Σ-V mini	SGMMV-A1	10 W	WN-05D	WN-05D	WN-05D	—	—	—	—	—	—	—	—	—
		SGMMV-A2	20 W	□25	WN-05D	WN-05D	WN-05D	—	—	—	—	—	—	—	—
		SGMMV-A3	30 W	□25	WN-05D	WN-05D	WN-05D	—	—	—	—	—	—	—	—
	Σ-V	SGMJV-A5	50 W	□40	—	WQ-08K	WQ-08K	WQ-08K WQ-08M	WQ-08K WQ-08M	—	—	—	—	—	—
					—	WQ-08K	WQ-08K	WQ-08K WQ-08M	WQ-08K WQ-08M	—	—	—	—	—	—
		SGMAV-A5	100 W		—	—	—	WQ-08K WQ-08M	WQ-08K WQ-08M	—	—	—	—	—	—
					—	—	—	WQ-08K WQ-08M	WQ-08K WQ-08M	—	—	—	—	—	—
		SGMJV-C2	150 W		—	—	—	WQ-08K WQ-08M	WQ-08K WQ-08M	—	—	—	—	—	—
					—	—	—	—	—	WV-14M	WV-14M	WV-14M	WV-14M	WV-14M	
		SGMJV-02	200 W		□60	—	—	—	—	—	—	WV-14M	WV-14M	WV-14M	WV-14M
						—	—	—	—	—	WV-14M	WV-14M	WV-14M	WV-14M	
		SGMAV-02	400 W			—	—	—	—	—	WV-14M	WV-14M	WV-14M	WV-14M	
	—			—		—	—	—	WV-14M	WV-14M	WV-14M	WV-14M			
	SGMJV-04	600 W	—	—		—	—	—	WV-14M	WV-14M	WV-14M	WV-14M			
			—	—		—	—	—	WV-14M	WV-14M	WV-14M	WV-14M			
	SGMAV-04	750 W	□80	—		—	—	—	—	—	—	WZ-19M	WZ-19M		
—				—		—	—	—	—	—	WZ-19M	WZ-19M			
SGMJV-06	—	—		—		—	—	—	—	—	—	—			
		—		—	—	—	—	—	—	—	—				
SGMJV-08	—	—		—	—	—	—	—	—	—	—				
		—		—	—	—	—	—	—	—	—				
SGMAV-08	—	—	—	—	—	—	—	—	—	—					
		—	—	—	—	—	—	—	—	—					

Motor type		Rated output	Flange size	KR										
				KR15	KR20	KR26	KR30H	KR33	KR45H	KR46	KR55	KR65		
AC servo motor	Yaskawa Electric	Σ -7	50 W	\square 40	—	WQ-08K	WQ-08K	WQ-08K WQ-08M	WQ-08K WQ-08M	—	—	—	—	
					—	WQ-08K	WQ-08K	WQ-08K WQ-08M	WQ-08K WQ-08M	—	—	—	—	
			100 W		—	—	—	WQ-08K WQ-08M	WQ-08K WQ-08M	—	—	—	—	
					—	—	—	WQ-08K WQ-08M	WQ-08K WQ-08M	—	—	—	—	
			150 W		—	—	—	WQ-08K WQ-08M	WQ-08K WQ-08M	—	—	—	—	
			200 W		—	—	—	—	—	—	WV-14M	WV-14M	WV-14M	WV-14M
		—		—	—	—	—	—	WV-14M	WV-14M	WV-14M	WV-14M		
		400 W		—	—	—	—	—	WV-14M	WV-14M	WV-14M	WV-14M		
				—	—	—	—	—	WV-14M	WV-14M	WV-14M	WV-14M		
		600 W		—	—	—	—	—	WV-14M	—	WV-14M	WV-14M		
		750 W		—	—	—	—	—	—	—	—	WZ-19M	WZ-19M	
			—	—	—	—	—	—	—	—	WZ-19M	WZ-19M		
		Σ -X	50 W	\square 40	—	WQ-08K	WQ-08K	WQ-08K WQ-08M	WQ-08K WQ-08M	—	—	—	—	
					—	WQ-08K	WQ-08K	WQ-08K WQ-08M	WQ-08K WQ-08M	—	—	—	—	
					100 W	—	—	—	WQ-08K WQ-08M	WQ-08K WQ-08M	—	—	—	—
						—	—	—	WQ-08K WQ-08M	WQ-08K WQ-08M	—	—	—	—
					150 W	—	—	—	WQ-08K WQ-08M	WQ-08K WQ-08M	—	—	—	—
						—	—	—	WQ-08K WQ-08M	WQ-08K WQ-08M	—	—	—	—
	200 W		\square 60	—	—	—	—	—	WV-14M	WV-14M	WV-14M	WV-14M		
				—	—	—	—	—	WV-14M	WV-14M	WV-14M	WV-14M		
				400 W	—	—	—	—	—	WV-14M	WV-14M	WV-14M	WV-14M	
					—	—	—	—	—	WV-14M	—	WV-14M	WV-14M	
				600 W	—	—	—	—	—	WV-14M	—	WV-14M	WV-14M	
					—	—	—	—	—	WV-14M	—	WV-14M	WV-14M	
750 W	\square 80	—	—	—	—	—	—	—	WZ-19M	WZ-19M				
		—	—	—	—	—	—	—	WZ-19M	WZ-19M				

Motor type		Rated output	Flange size	KR											
				KR15	KR20	KR26	KR30H	KR33	KR45H	KR46	KR55	KR65			
AC servo motor	Mitsubishi Electric	MELSERVO	J4	HG-AK0136	10 W	□25	WN-05D	WN-05D	WN-05D	—	—	—	—	—	—
				HG-AK0236	20 W		WN-05D	WN-05D	WN-05D	—	—	—	—	—	—
				HG-AK0336	30 W		WN-05D	WN-05D	WN-05D	—	—	—	—	—	—
			HG-MR053	50 W	□40	—	WQ-08D	WQ-08D	WQ-08D WQ-08M	WQ-08D WQ-08M	—	—	—	—	
			HG-KR053			—	WQ-08D	WQ-08D	WQ-08D WQ-08M	WQ-08D WQ-08M	—	—	—	—	
			HG-MR13	100 W	□40	—	—	—	WQ-08D WQ-08M	WQ-08D WQ-08M	—	—	—	—	
			HG-KR13			—	—	—	WQ-08D WQ-08M	WQ-08D WQ-08M	—	—	—	—	
			HG-MR23	200 W	□60	—	—	—	—	—	WV-14M	WV-14M	WV-14M	WV-14M	
			HG-KR23			—	—	—	—	—	WV-14M	WV-14M	WV-14M	WV-14M	
		HG-MR43	400 W	□60	—	—	—	—	—	WV-14M	WV-14M	WV-14M	WV-14M		
		HG-KR43			—	—	—	—	—	WV-14M	WV-14M	WV-14M	WV-14M		
		HG-MR73	750 W	□80	—	—	—	—	—	—	—	WZ-19M	WZ-19M		
		HG-KR73			—	—	—	—	—	—	—	WZ-19M	WZ-19M		
		J5	□40	HK-KT053W	50 W	—	WQ-08D	WQ-08D	WQ-08D WQ-08M	WQ-08D WQ-08M	—	—	—	—	
				HK-KT13W	100 W	—	—	—	WQ-08D WQ-08M	WQ-08D WQ-08M	—	—	—	—	
				HK-KT23W	200 W	□60	—	—	—	—	WV-14M	WV-14M	WV-14M	WV-14M	
			HK-KT43W	400 W	□60	—	—	—	—	WV-14M	WV-14M	WV-14M	WV-14M		
			HK-KT7M3W	750 W	□80	—	—	—	—	—	—	WZ-19M	WZ-19M		
	□40		HF-KN053	50 W	—	WQ-08D	WQ-08D	WQ-08D WQ-08M	WQ-08D WQ-08M	—	—	—	—		
			HF-KN13	100 W	—	—	—	WQ-08D WQ-08M	WQ-08D WQ-08M	—	—	—	—		
			HF-KN23	200 W	□60	—	—	—	—	WV-14M	WV-14M	WV-14M	WV-14M		
	HF-KN43		400 W	□60	—	—	—	—	WV-14M	WV-14M	WV-14M	WV-14M			
	Tamagawa Seiki Co., Ltd.	TBL-I-II	TS4602	50 W	□40	—	WQ-08D	WQ-08D	WQ-08D WQ-08M	WQ-08D WQ-08M	—	—	—	—	
			TS4603	100 W		—	—	—	WQ-08D WQ-08M	WQ-08D WQ-08M	—	—	—	—	
			TS4604	150 W		—	—	—	WQ-08D WQ-08M	WQ-08D WQ-08M	—	—	—	—	
			TS4607	200 W	□60	—	—	—	—	WV-14M	WV-14M	WV-14M	WV-14M		
			TS4609	400 W	□60	—	—	—	—	WV-14M	WV-14M	WV-14M	WV-14M		
			TS4614	750 W	□80	—	—	—	—	—	—	WZ-19M	WZ-19M		
		TBL-IV	TSM3102	50 W	□40	—	WQ-08D	WQ-08D	WQ-08D WQ-08M	WQ-08D WQ-08M	—	—	—	—	
			TSM3104	100 W		—	—	—	WQ-08D WQ-08M	WQ-08D WQ-08M	—	—	—	—	
TSM3202			200 W	□60	—	—	—	—	—	WV-14M	—	WV-14M	WV-14M		
TSM3204			400 W		—	—	—	—	—	WV-14M	—	WV-14M	WV-14M		
TSM3303			600 W	□80	—	—	—	—	—	—	WV-14M	WZ-19M	WZ-19M		
TSM3304			750 W		—	—	—	—	—	—	WV-14M	WZ-19M	WZ-19M		

Motor type				Rated output	Flange size	KR										
						KR15	KR20	KR26	KR30H	KR33	KR45H	KR46	KR55	KR65		
AC servo motor	Panasonic Corp.	MINAS	A5	MSMD5A	50 W	□38	—	WP-08D WP-08K	WP-08D WP-08K	WP-08D WP-08K WP-08M	WP-08D WP-08K WP-08M	—	—	—	—	
				MSME5A			—	WP-08D WP-08K	WP-08D WP-08K	WP-08D WP-08K WP-08M	WP-08D WP-08K WP-08M	—	—	—	—	
				MSMD01	100 W		—	—	—	WP-08D WP-08K WP-08M	WP-08D WP-08K WP-08M	—	—	—	—	—
				MSME01			—	—	—	WP-08D WP-08K WP-08M	WP-08D WP-08K WP-08M	—	—	—	—	—
			MSMD02	200 W	□60		—	—	—	—	—	—	WY-11M	WY-11M	—	—
			MSME02				—	—	—	—	—	WY-11M	WY-11M	—	—	
			MSMD04	400 W			—	—	—	—	—	WY-14M	WY-14M	—	—	
			MSME04				—	—	—	—	—	WY-14M	WY-14M	—	—	
		MSMD08	750 W	□80		—	—	—	—	—	—	—	—	W5-19M	W5-19M	
		MSME08				—	—	—	—	—	—	—	W5-19M	W5-19M		
		MSMF5A	50 W			□38	—	WP-08K	WP-08K	WP-08K WP-08M	WP-08K WP-08M	—	—	—	—	
		MHMF5A				□40	—	WQ-08K	WQ-08K	WQ-08K WQ-08M	WQ-08K WQ-08M	—	—	—	—	
		MSMF01	100 W		□38	—	—	—	WP-08K WP-08M	WP-08K WP-08M	—	—	—	—		
		MHMF01			□40	—	—	—	WQ-08K WQ-08M	WQ-08K WQ-08M	—	—	—	—		
	MSMF02	200 W	□60		—	—	—	—	—	—	WY-11M	WY-11M	—	—		
	MHMF02				—	—	—	—	—	—	WY-11M	WY-11M	—	—		
	MSMF04	400 W		—	—	—	—	—	—	WY-14M	WY-14M	—	—			
	MHMF04			—	—	—	—	—	—	WY-14M	WY-14M	—	—			
	MSMF08	750 W		□80	—	—	—	—	—	—	—	—	W5-19M	W5-19M		
	MHMF08				—	—	—	—	—	—	—	—	W5-19M	W5-19M		
	Keyence Corporation	SV			SV-M005	50 W	□40	—	WQ-08K	WQ-08K	WQ-08K WQ-08M	WQ-08K WQ-08M	—	—	—	—
					SV-M010			100 W	—	—	—	WQ-08K WQ-08M	WQ-08K WQ-08M	—	—	—
			SV-M020		200 W	—		—	—	—	—	WV-14M	WV-14M	WV-14M	WV-14M	
			SV-M040		400 W	□60		—	—	—	—	WV-14M	WV-14M	WV-14M	WV-14M	
			SV-M075		750 W	□80		—	—	—	—	—	—	WZ-19M	WZ-19M	
		SV2	SV2-M005		50 W	□40	—	WQ-08K	WQ-08K	WQ-08K WQ-08M	WQ-08K WQ-08M	—	—	—	—	
			SV2-M010	100 W			—	—	—	WQ-08K WQ-08M	WQ-08K WQ-08M	—	—	—	—	
			SV2-M020	200 W	—		—	—	—	—	WV-14M	WV-14M	WV-14M	WV-14M		
SV2-M040			400 W	□60	—		—	—	—	WV-14M	WV-14M	WV-14M	WV-14M			
SV2-M075			750 W	□80	—		—	—	—	—	—	WZ-19M	WZ-19M			

Motor type				Rated output	Flange size	KR								
						KR15	KR20	KR26	KR30H	KR33	KR45H	KR46	KR55	KR65
AC servo motor	SANYO DENKI	SANMOTION R	R2□A04005	50 W	□40	—	WQ-08K	WQ-08K	WQ-08M	WQ-08M	—	—	—	—
			R2EA04008	80 W		—	—	—	WQ-08M	WQ-08M	—	—	—	—
			R2□A04010	100 W		—	—	—	WQ-08M	WQ-08M	—	—	—	—
			R2□A06020	200 W	□60	—	—	—	—	—	WV-14M	WV-14M	WV-14M	WV-14M
			R2AA06040	400 W		—	—	—	—	WV-14M	WV-14M	WV-14M	WV-14M	
			R2AA08075	750 W	□80	—	—	—	—	—	—	—	WZ-16M	WZ-16M
	Omron	OMNUC G5	R88M-K05030	50 W	□40	—	WQ-08K	WQ-08K	WQ-08K WQ-08M	WQ-08K WQ-08M	—	—	—	—
			R88M-K10030	100 W		—	—	—	WQ-08K WQ-08M	WQ-08K WQ-08M	—	—	—	—
			R88M-K20030	200 W	□60	—	—	—	—	—	WY-11M	WY-11M	—	—
			R88M-K40030	400 W		—	—	—	—	—	WY-14M	WY-14M	—	—
			R88M-K75030	750 W	□80	—	—	—	—	—	—	—	W5-19M	W5-19M
		1S	R88M-1M10030	100 W	□40	—	—	—	WQ-08K WQ-08M	WQ-08K WQ-08M	—	—	—	—
			R88M-1M20030	200 W	□60	—	—	—	—	—	WY-11M	WY-11M	—	—
			R88M-1M40030	400 W		—	—	—	—	—	WY-14M	WY-14M	—	—
			R88M-1M75030	750 W	□80	—	—	—	—	—	—	—	W5-19M	W5-19M
		Fanuc	β is series	βis0.2/5000	50 W	□40	—	WQ-08K	WQ-08K	—	—	—	—	—

Note 1) The symbols in the table indicate the housing A and intermediate flange.

Note 2) For the motor coupling, contact THK.

Note 3) The motor types in the table represent only some of the types available. For details regarding different types, please see the catalog from each respective motor manufacturer.

Note 4) Model KR15 has a limit in input torque. The permissible input torque for model KR1501 is 0.051 N·m at a maximum, and that for model KR1502 is 0.103 N·m at a maximum. If the maximum torque of the motor mounted to model KR15 exceeds the permissible input torque, take a safety measure such as setting a torque limit.

[Dimensional Drawing of Housing A/Intermediate Flange for Model KR]

● For Model KR15

KR**	··· Actuator model number
●◇	···●: Housing A ◇: Intermediate flange

■Housing A

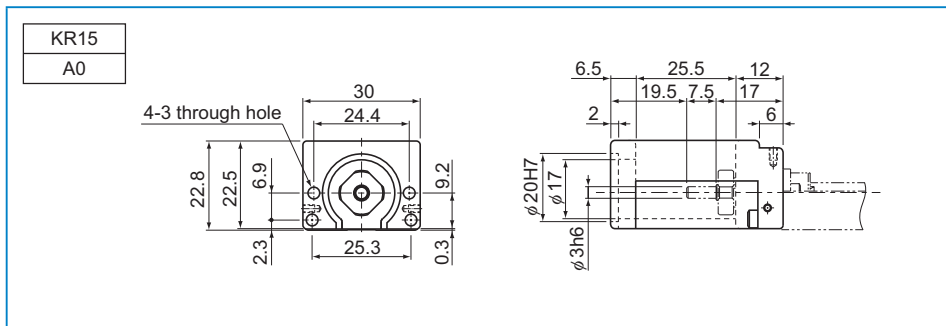

■Intermediate Flange

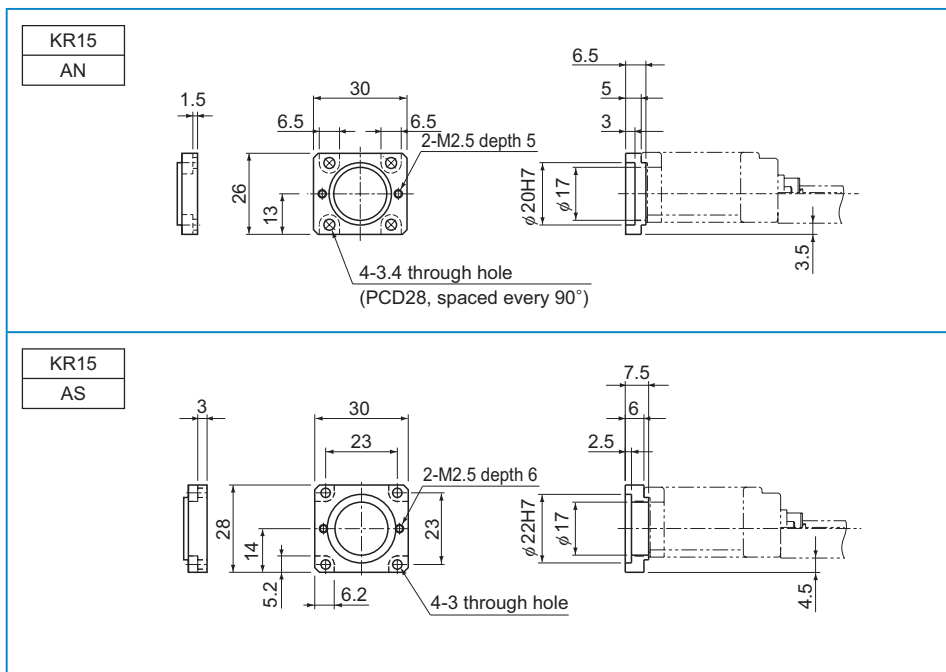

■ Motor Wrap Housing A

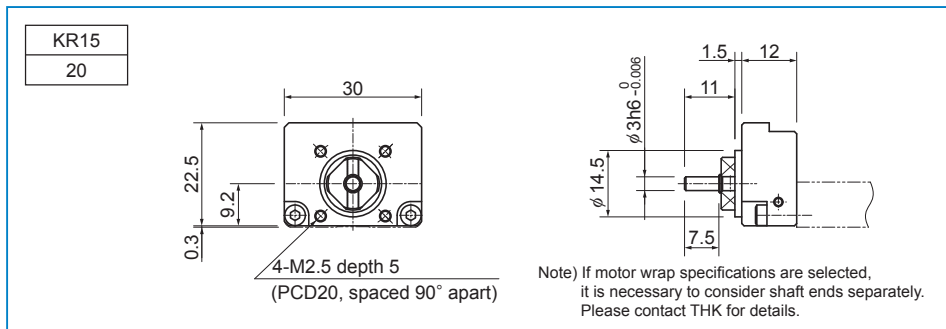

KR**	··· Actuator model number
W□	··· □: Intermediate flange

■ Motor Wrap Specifications (Intermediate Flange)

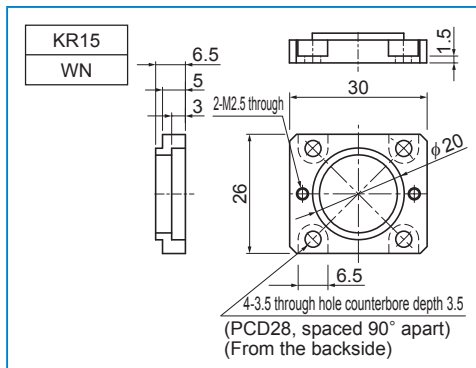

● For Model KR20

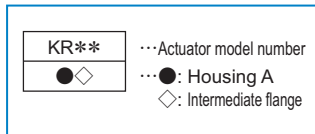

■ Housing A

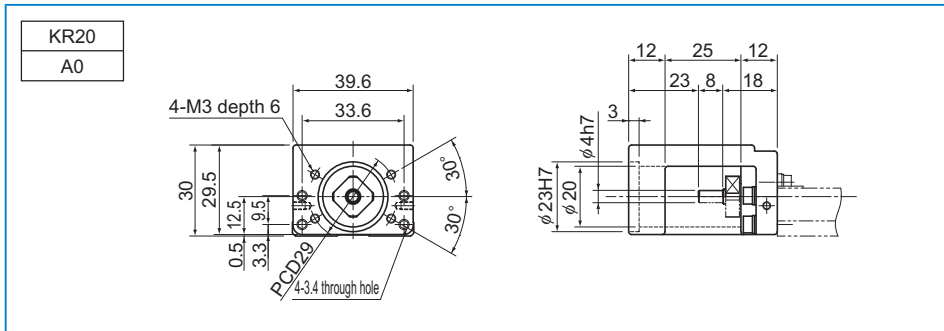

■ Intermediate Flange

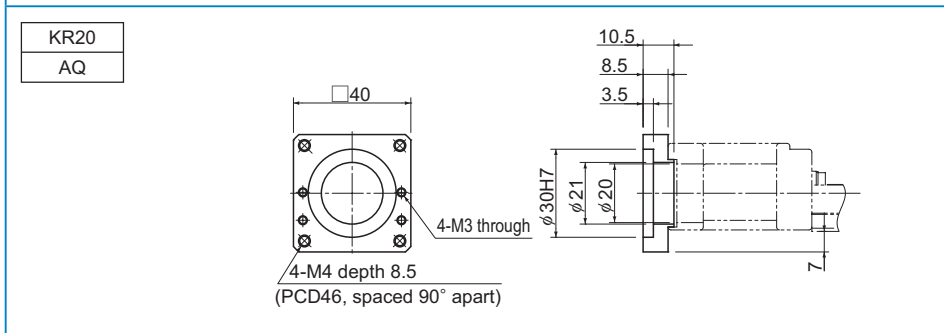
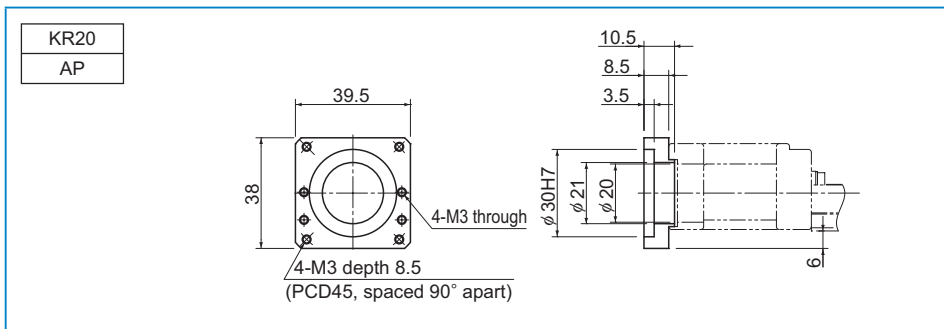

KR20

AR

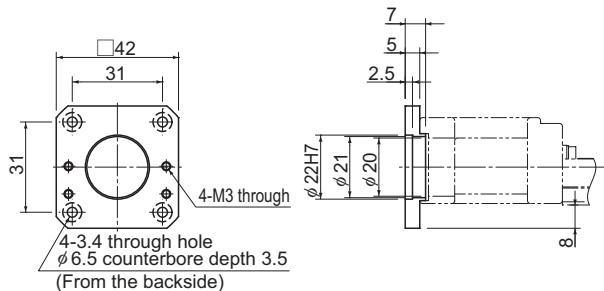

KR20

AS

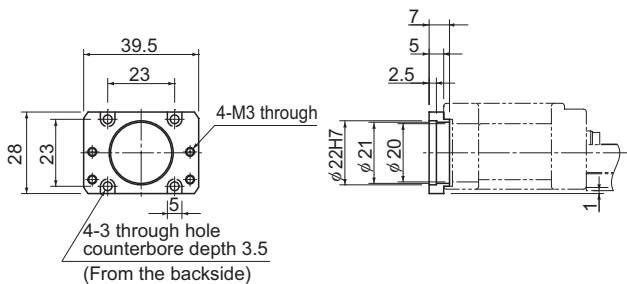

KR20

AN

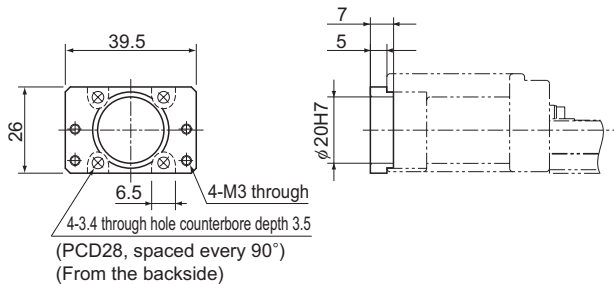

Motor Wrap Housing A

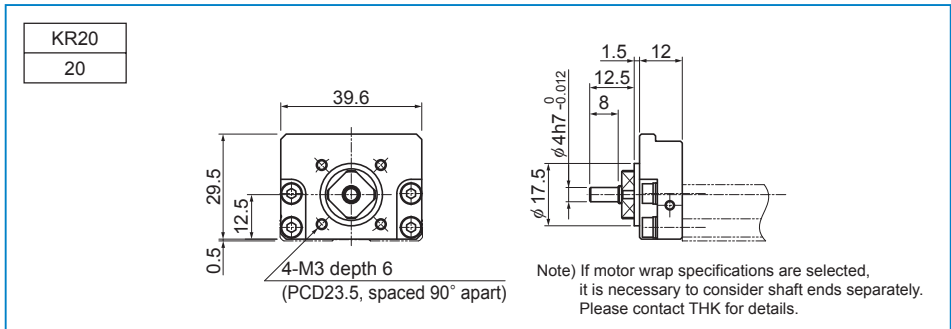

KR**	··· Actuator model number
W□	··· □: Intermediate flange

Motor Wrap Specifications (Intermediate Flange)

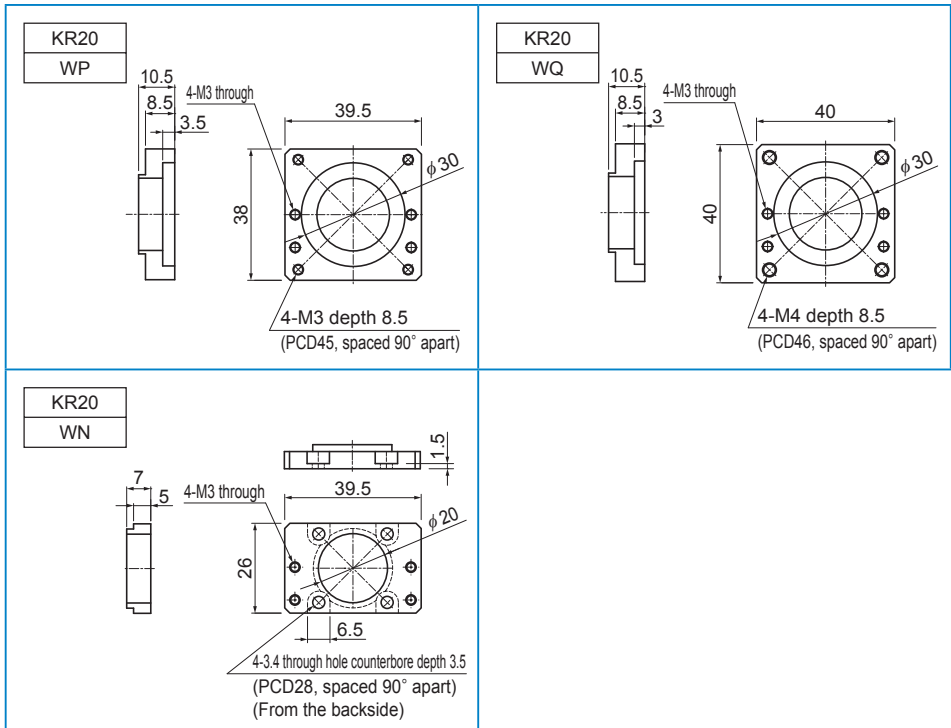

● For Model KR26

KR**	···· Actuator model number
● ◆	····●: Housing A
◆	◆: Intermediate flange

■ Housing A

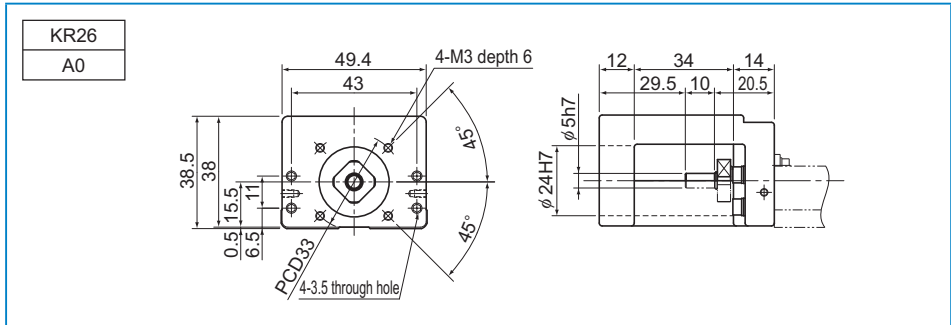

■ Intermediate Flange

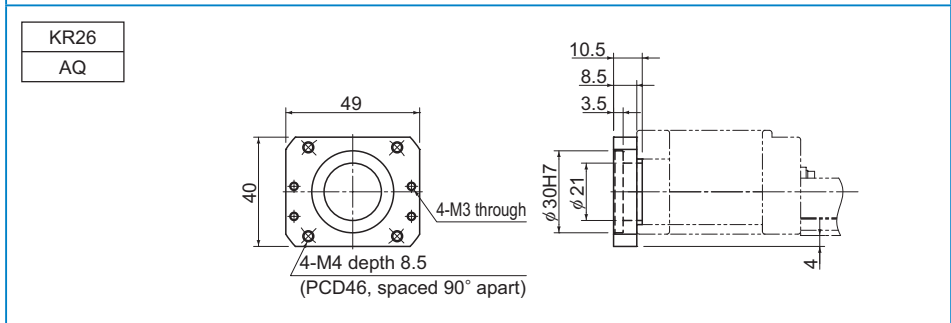
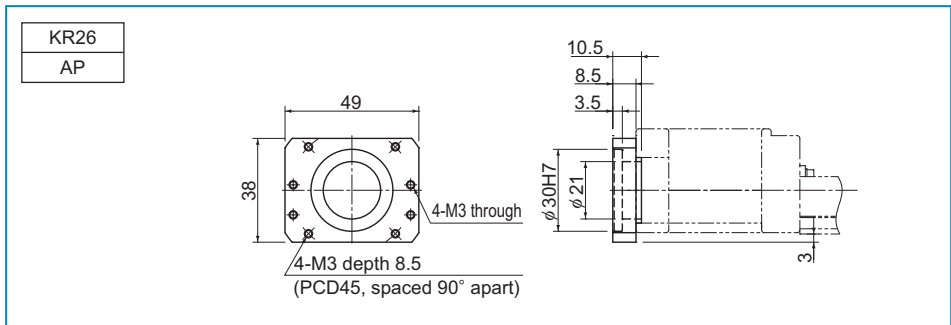

KR26

AR

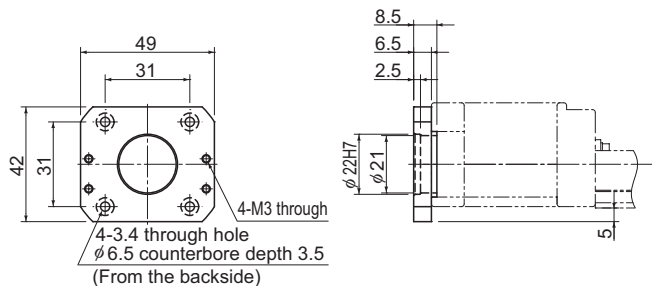

KR26

AS

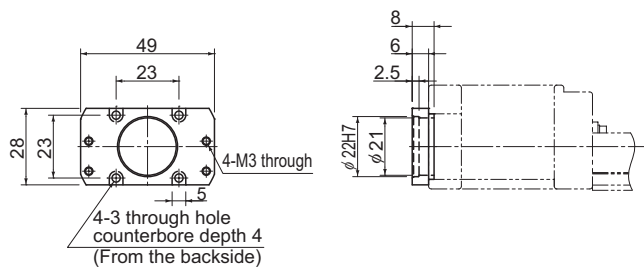

KR26

AN

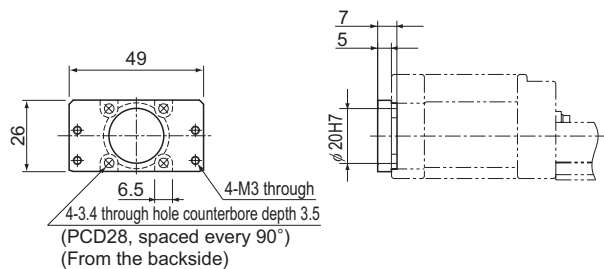

Motor Wrap Housing A

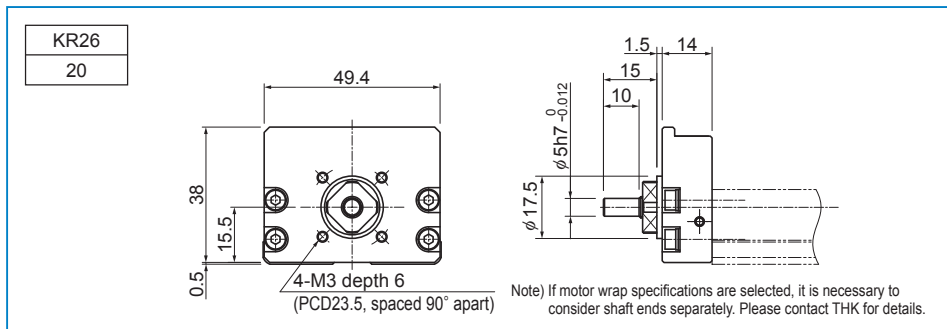

KR**	...Actuator model number
W□	...□: Intermediate flange

Motor Wrap Specifications (Intermediate Flange)

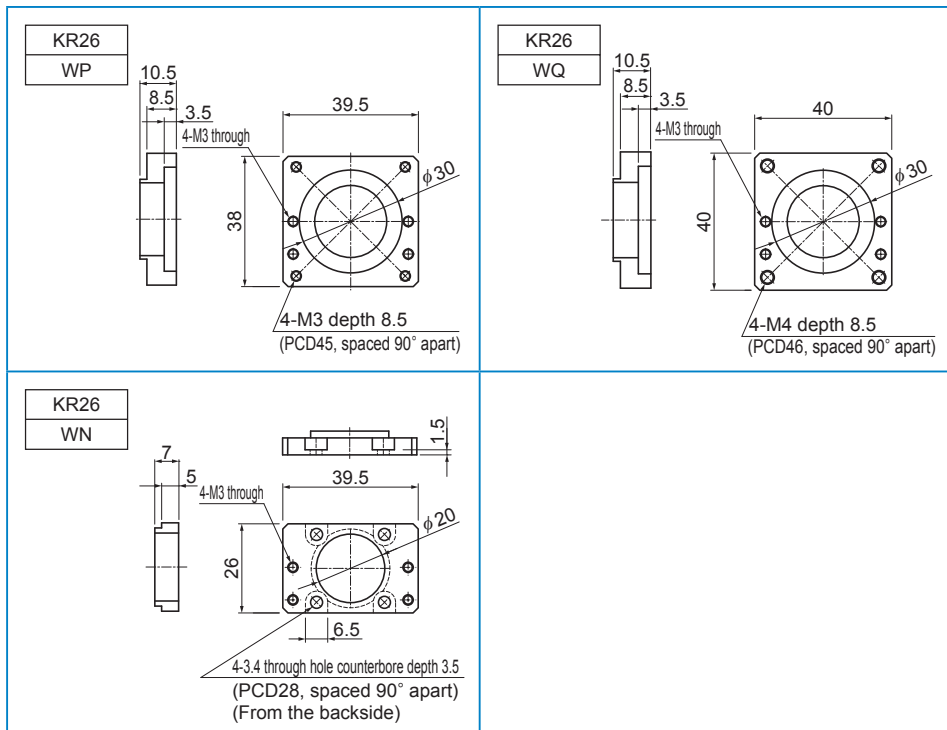

● For Model KR30H

KR**	··· Actuator model number
●◇	··· ●: Housing A ◇: Intermediate flange

■ Housing A

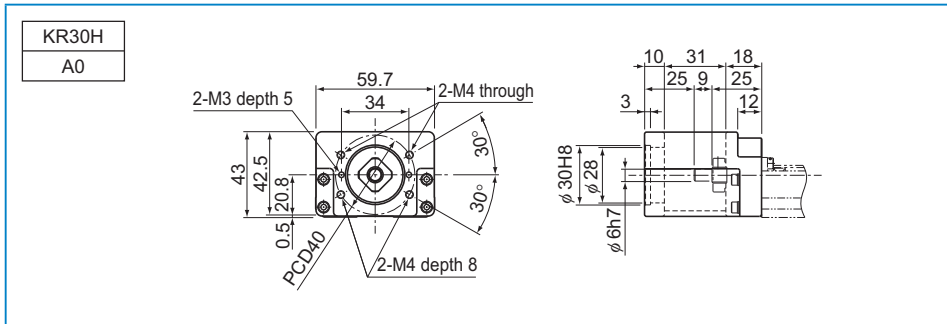

■ Intermediate Flange

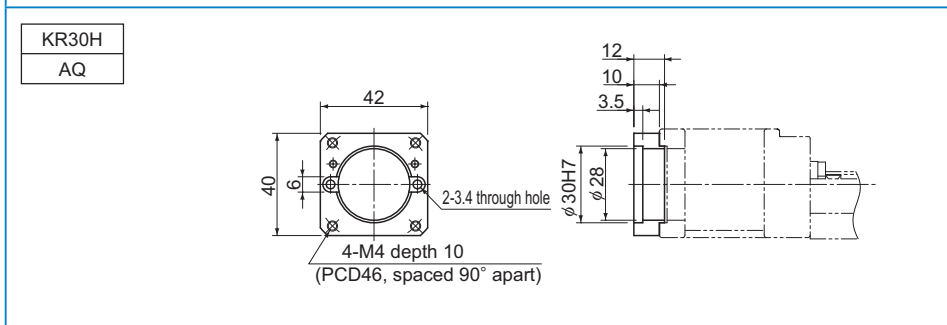
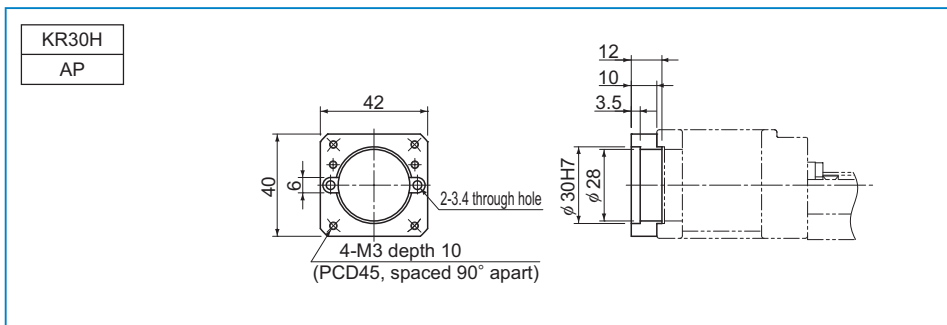

KR30H

AR

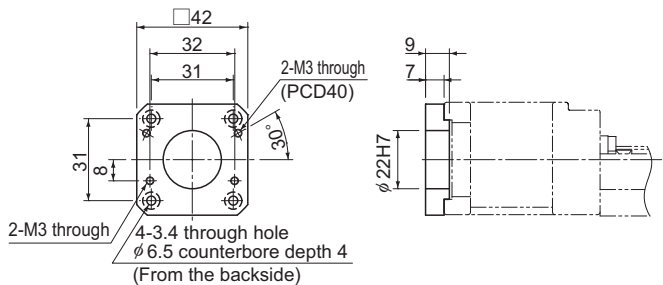

KR30H

AT

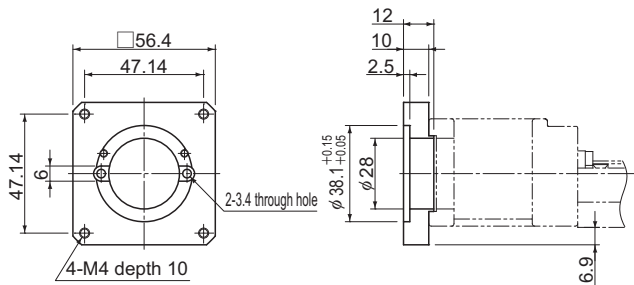

KR30H

AU

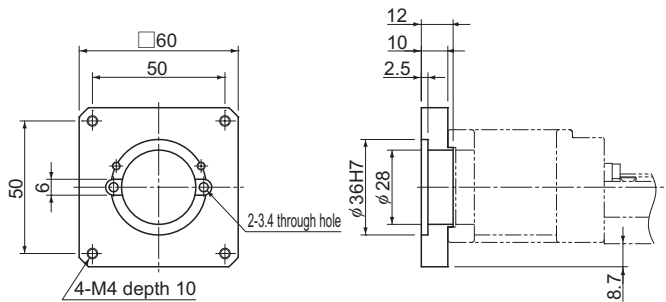

Motor Wrap Housing A

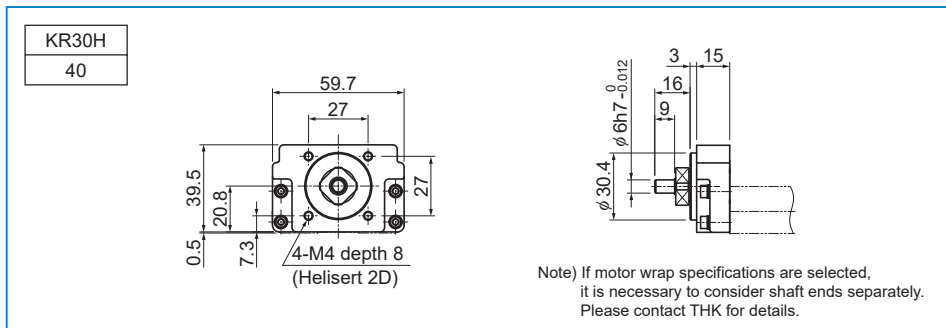

KR**	... Actuator model number
W□	... □: Intermediate flange

Motor Wrap Specifications (Intermediate Flange)

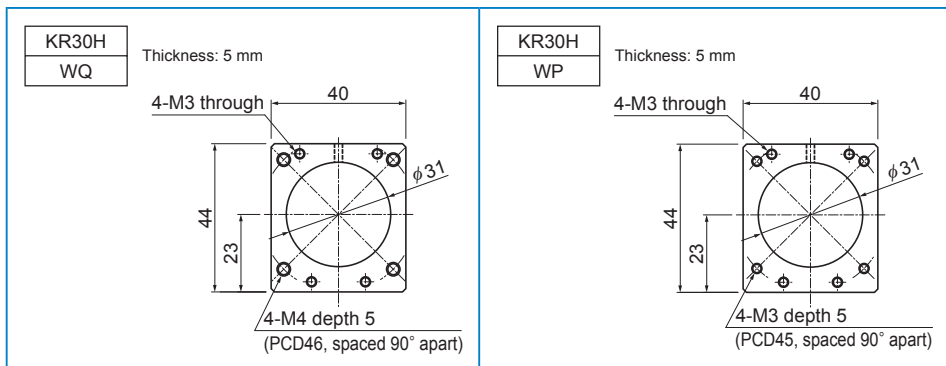

● For Model KR33

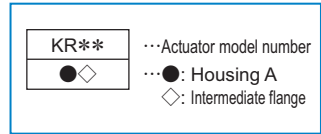

■ Housing A

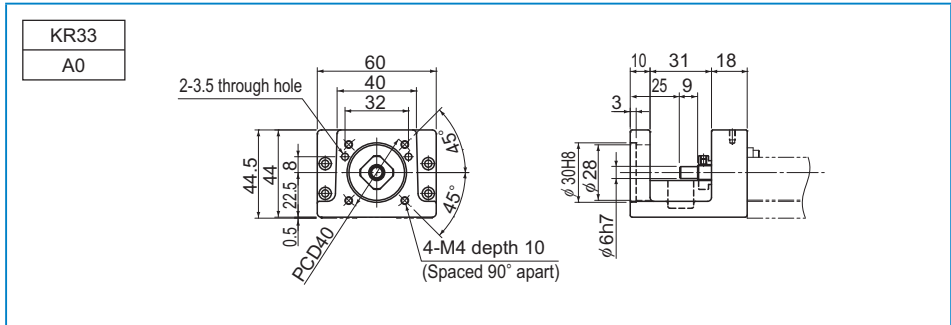

■ Intermediate Flange

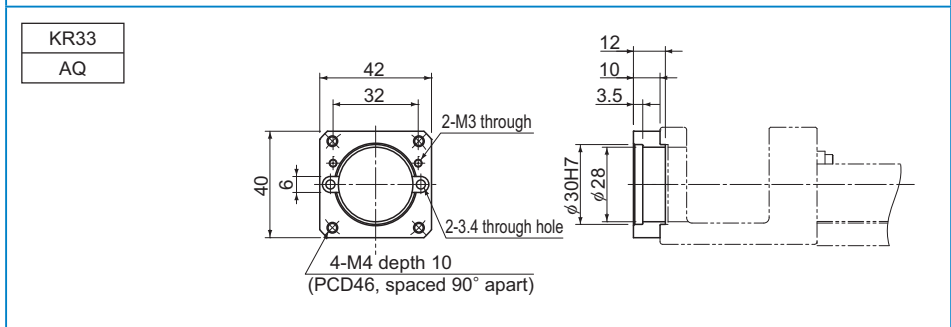
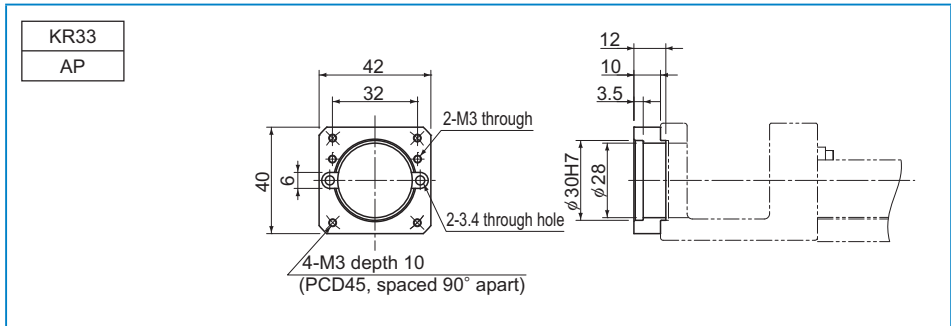

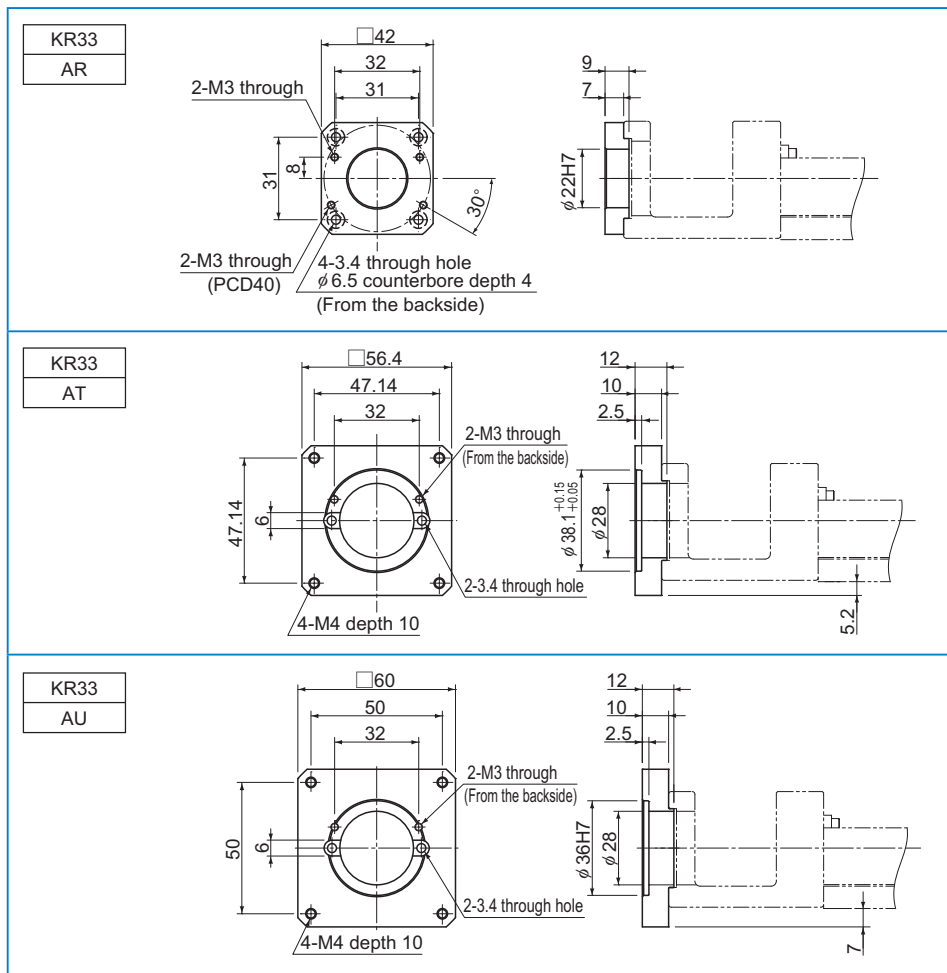

■ Motor Wrap Housing A

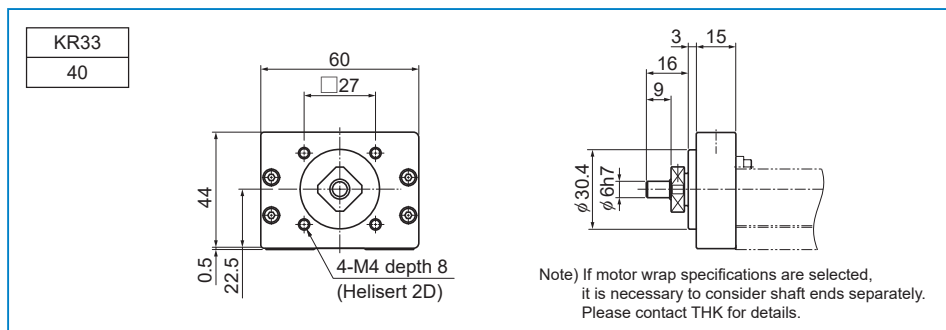

KR**	... Actuator model number
W□	... □: Intermediate flange

■ Motor Wrap Specifications (Intermediate Flange)

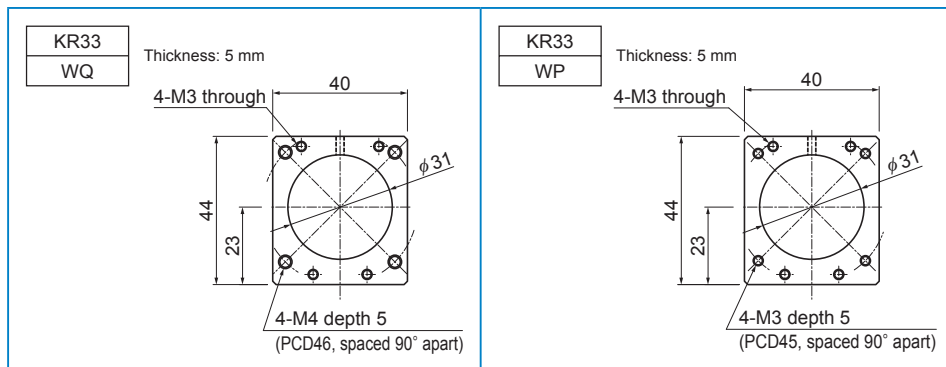

● For Model KR45H

KR**	--- Actuator model number
●	--- Housing A
◇	--- Intermediate flange

■ Housing A

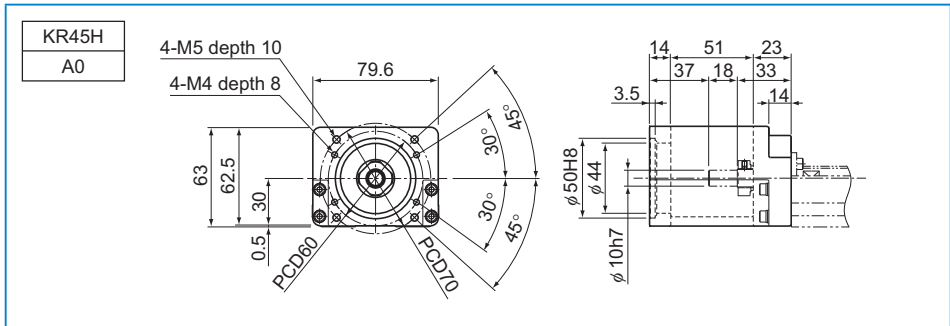

■ Intermediate Flange

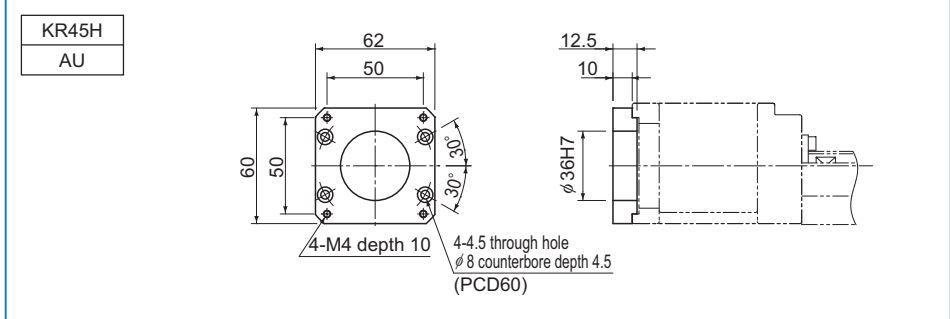
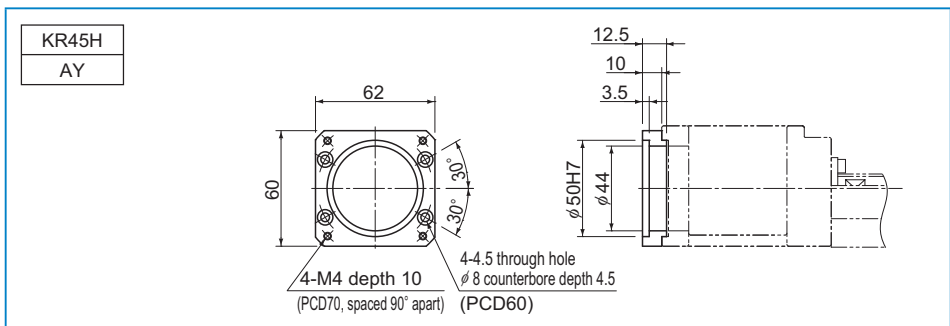

LM Guide Actuator (Options)

■ Motor Wrap Housing A

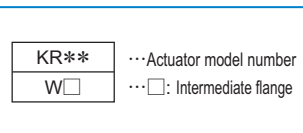
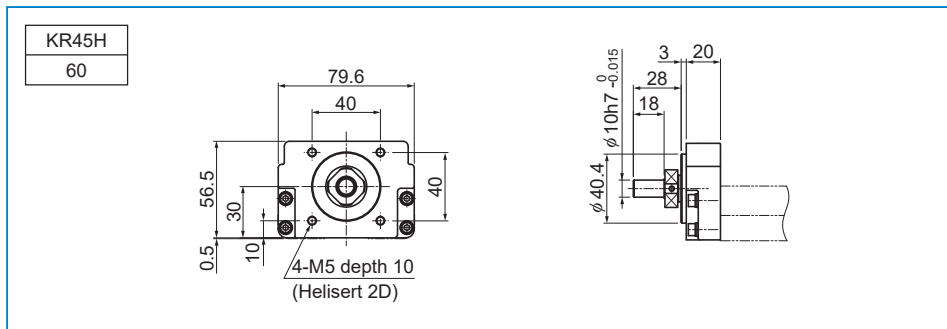

■ Motor Wrap Specifications (Intermediate Flange)

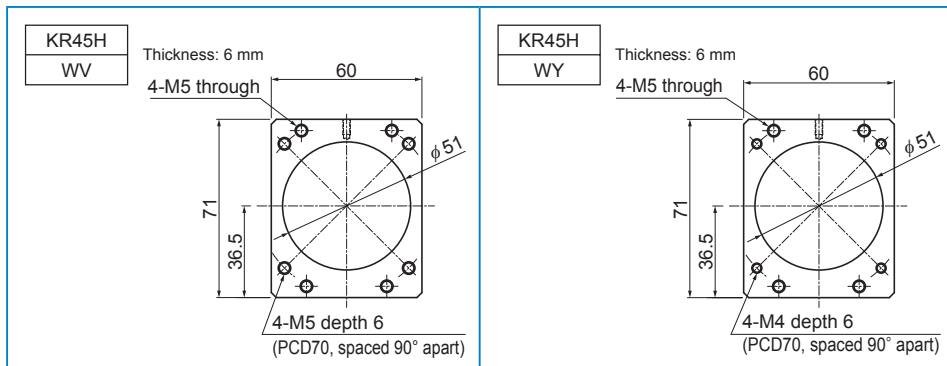

● For Model KR46

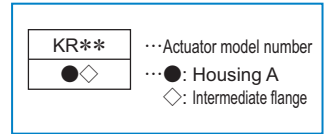

■ Housing A

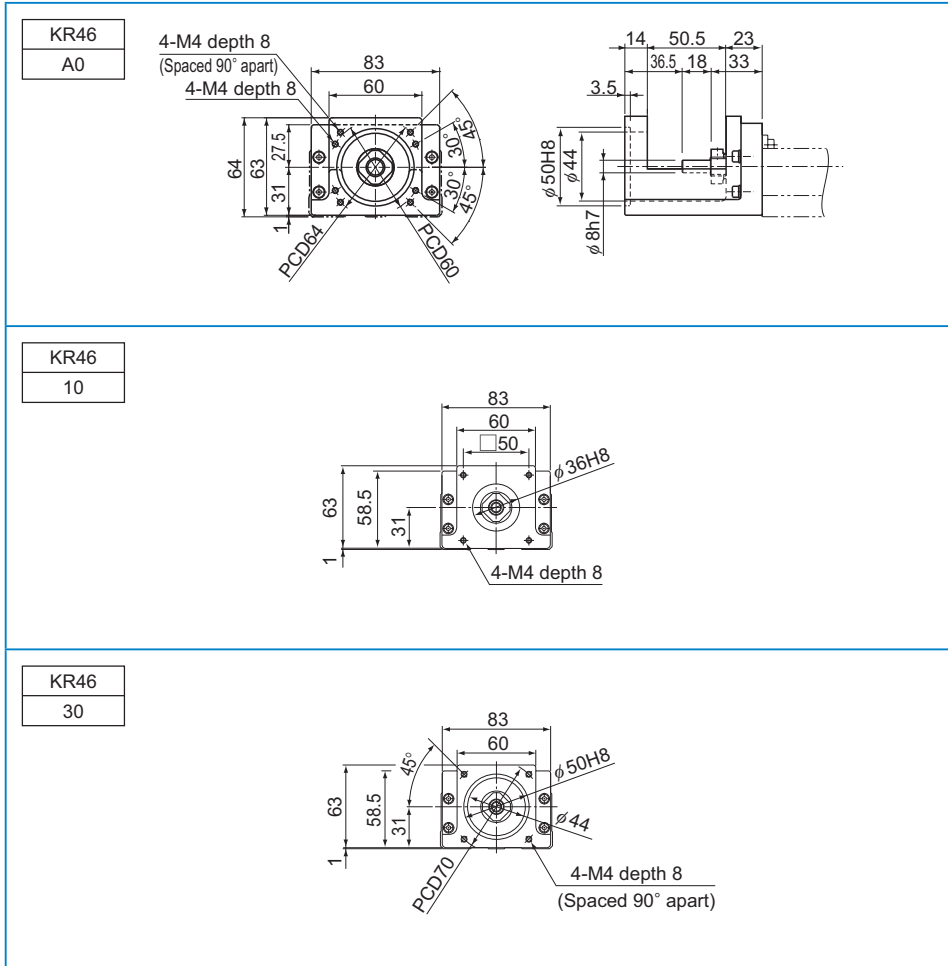

KR46

40

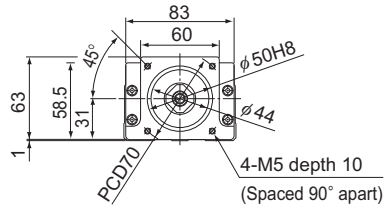

Motor Wrap Housing A

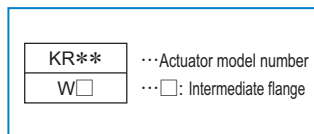
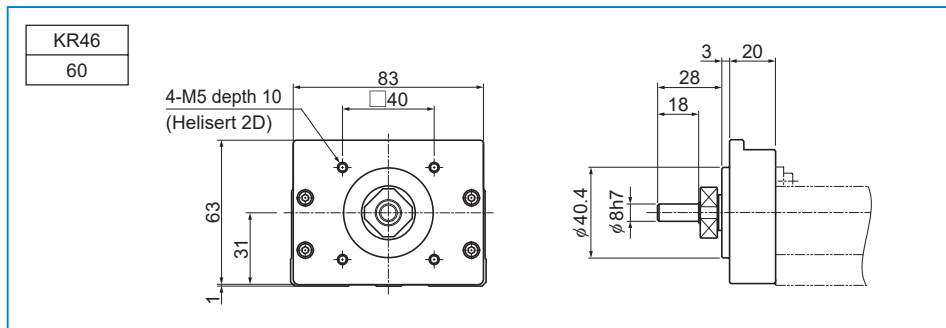

Motor Wrap Specifications (Intermediate Flange)

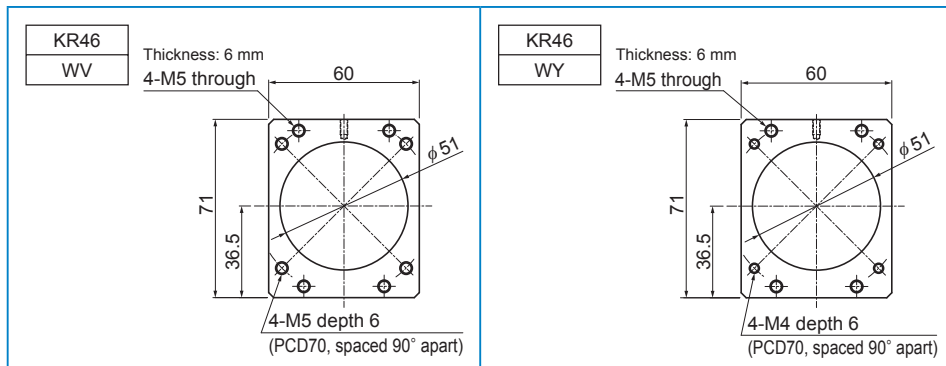

● For Model KR55

KR**	···· Actuator model number
●◇	····●: Housing A
	◇: Intermediate flange

■ Housing A

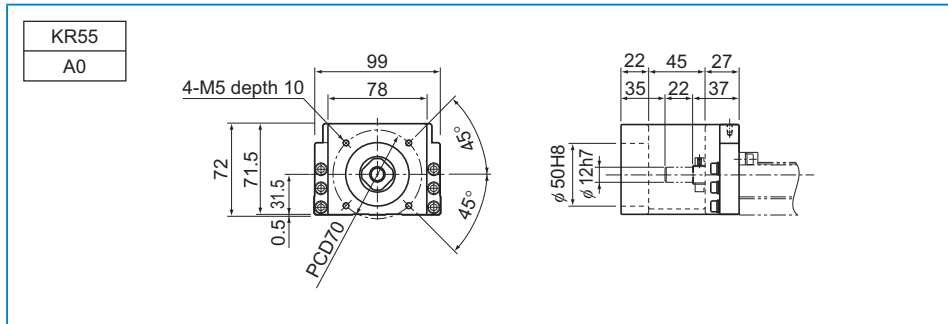

■ Intermediate Flange

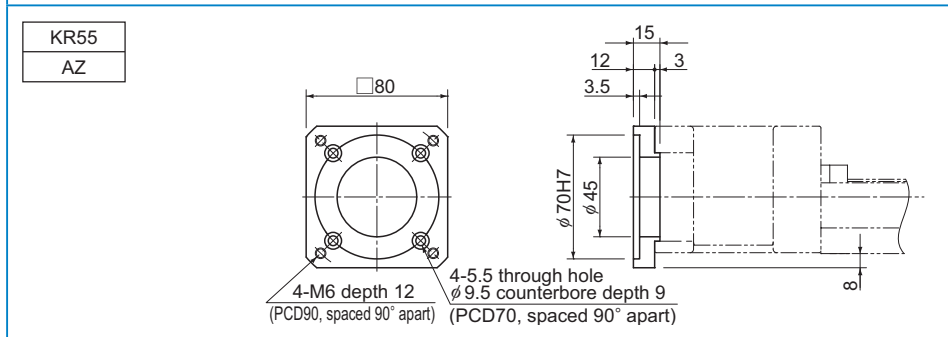
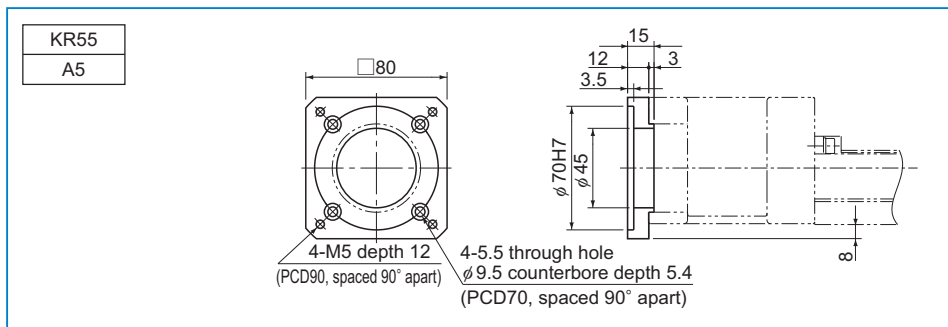

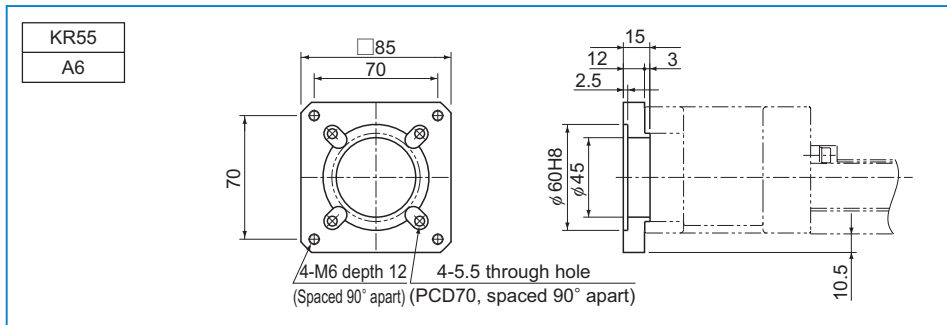

Motor Wrap Housing A

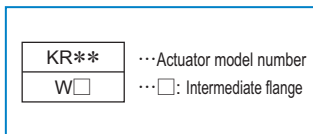
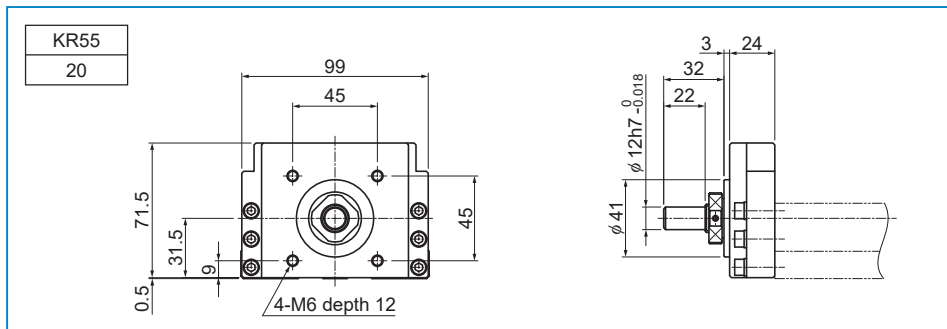

Motor Wrap Specifications (Intermediate Flange)

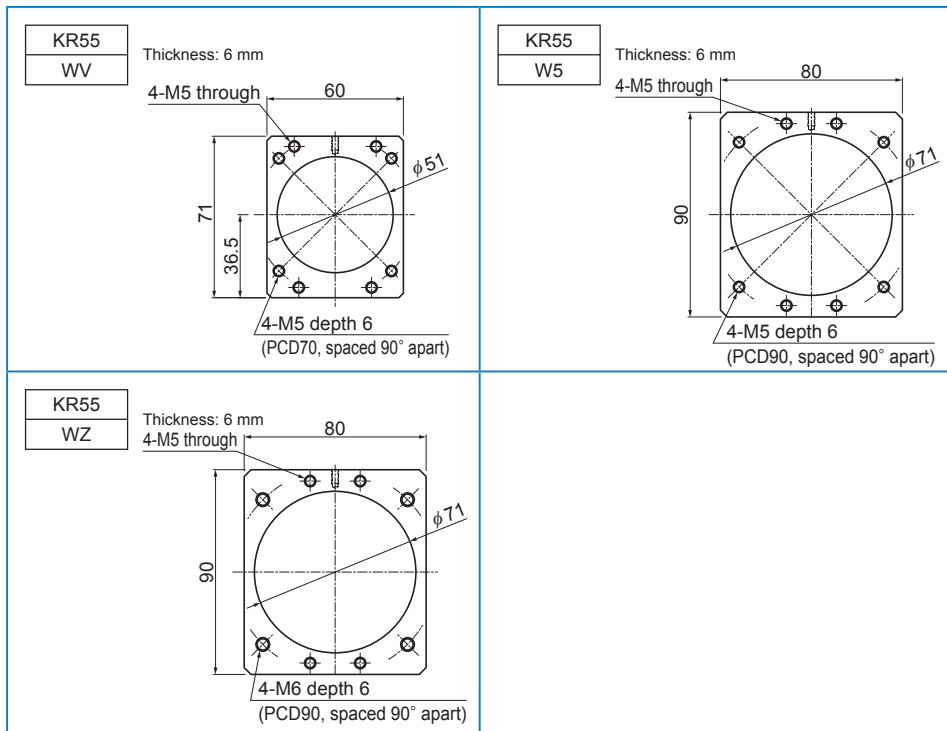

● For Model KR65

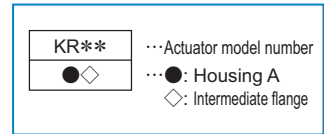

■ Housing A

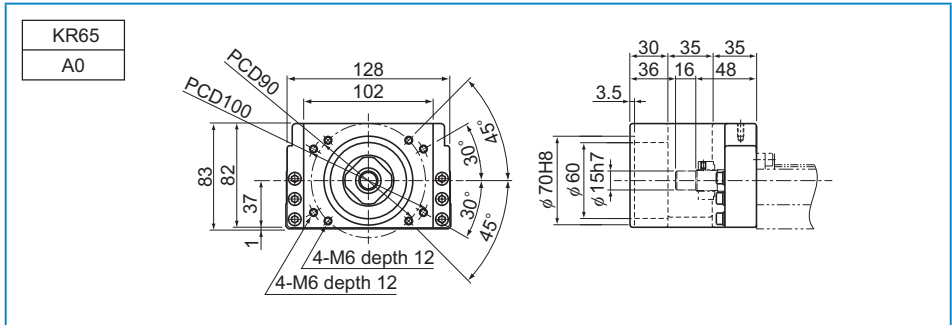

■ Intermediate Flange

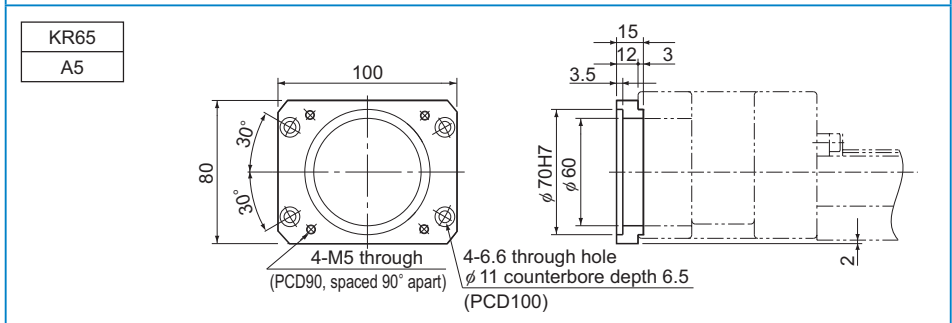
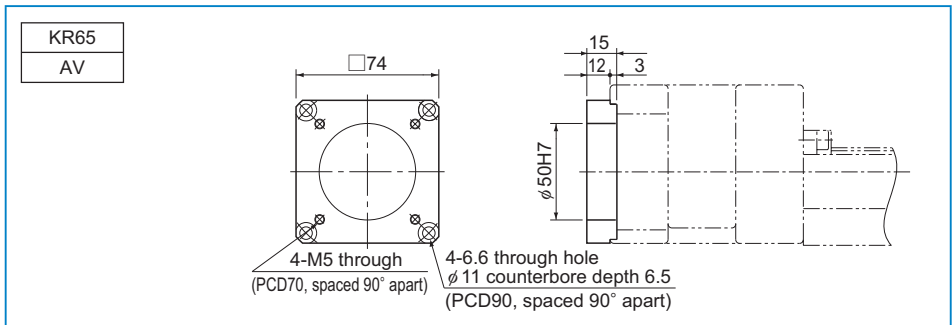

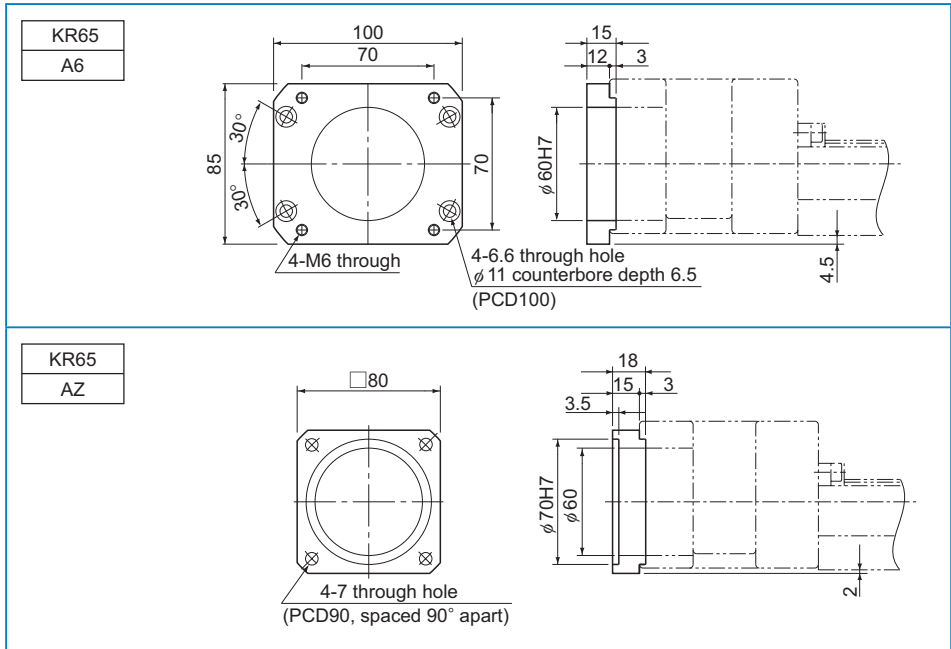

Motor Wrap Housing A

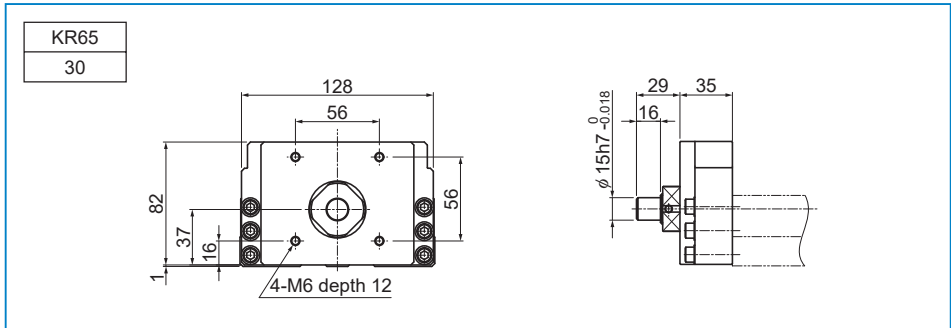

KR**	··· Actuator model number
W□	··· □: Intermediate flange

Motor Wrap Specifications (Intermediate Flange)

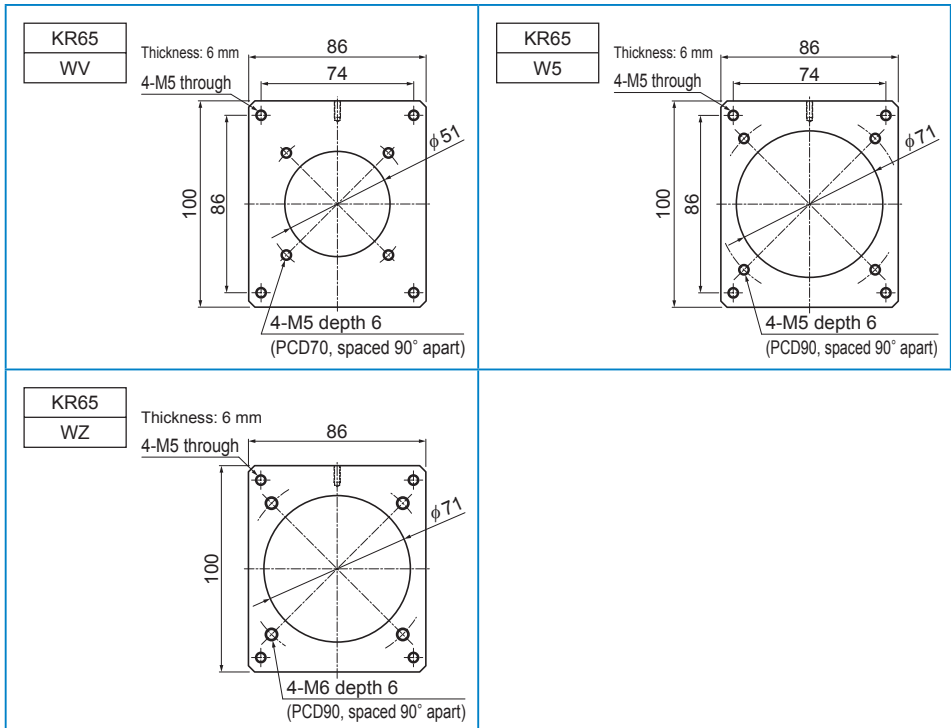

XY Bracket (for Reference)

Brackets for installing models SKR33/46 and models KR33/46 only are available. The brackets use aluminum to reduce the weight and keep inertia as low as possible.

[KR-008XS (for Model KR33, Single-Shaft Type, and for Model SKR33, without Cover, Single-Shaft Type)]

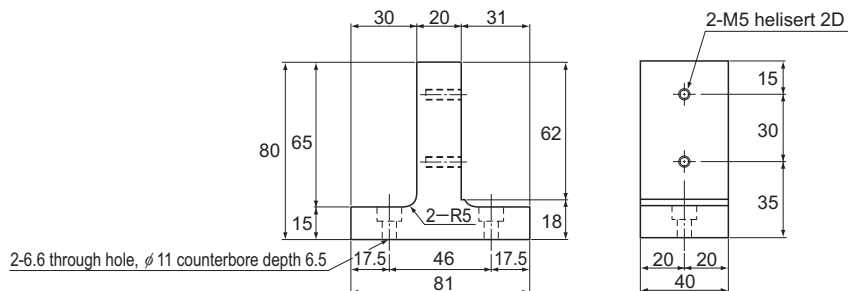

[KR-008XL (for Model KR46, Single-Shaft Type, and for Model SKR46, Single-Shaft Type)]

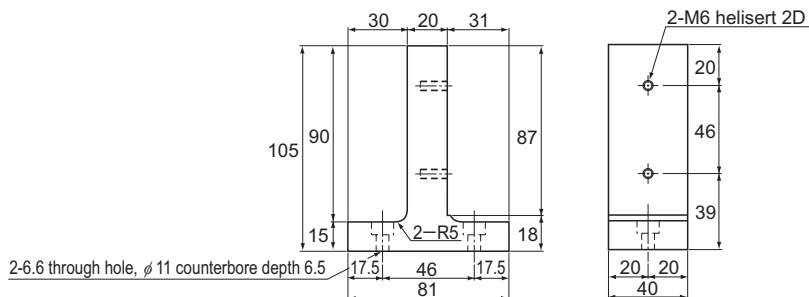

[KR-003XS (for Model KR33, Outer Rail Fixed, and for Model SKR33, without Cover, Outer Rail Fixed)]

KR46A+KR33A

SKR46A+SKR33A
Without cover

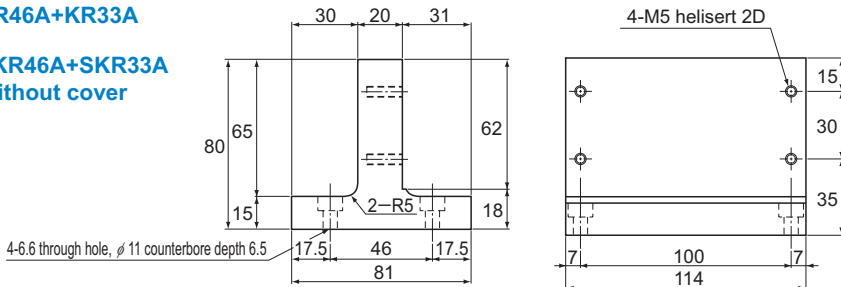

[KR-003XL (for Model KR46, Outer Rail Fixed, and for Model SKR46, Outer Rail Fixed)]

KR46A+KR46A

SKR46A+SKR46A

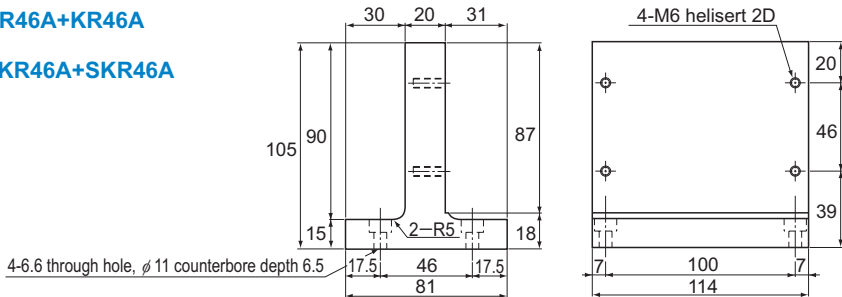

[KR-002XS (for Model KR33, Slider Fixed, and for Model SKR33, with Cover, Slider Fixed)]

KR46A+KR33A

SKR46A+SKR33A
With a cover

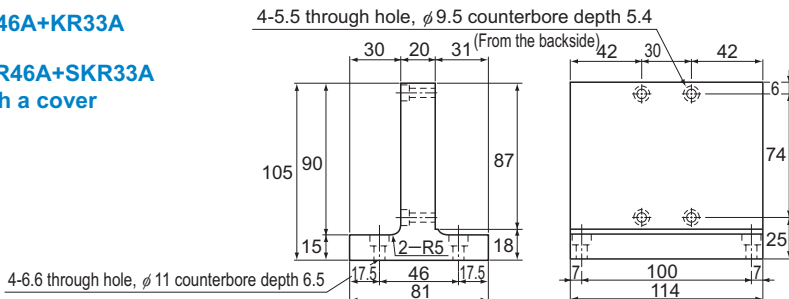

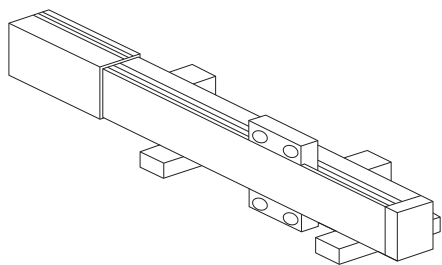
[Example Combinations]

Single shaft

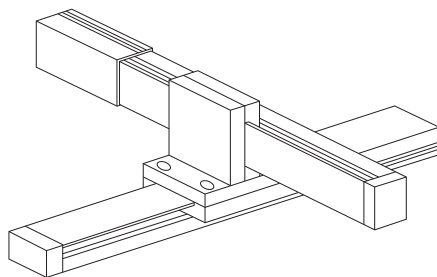

Fixed slider

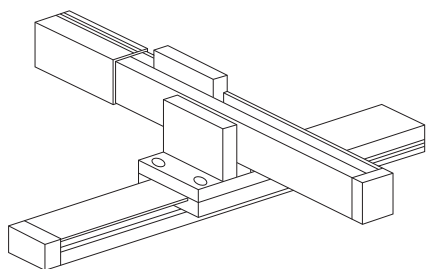

Fixed outer rail

Model No.

LM Guide Actuator

Model No.	Ball screw lead	Inner block type	QZ specification	Stroke	Accuracy grade
SKR33	10	A	QZ	0270	P
①	②	③	④	⑤	⑥
SKR20	01: 1 mm	A	No symbol : No QZ	0020: 20 mm	No symbol: Normal grade
SKR26	02: 2 mm	B	QZ	0025: 25 mm	H: High accuracy grade
SKR33	06: 6 mm	C	QZA	}	P: Precision grade
SKR46	10: 10 mm	D	QZB	1490: 1490 mm	
SKR55	20: 20 mm		QZAD		
SKR65	25: 25 mm				

KR15	40: 40 mm
KR20	50: 50 mm
KR26	
KR30H	
KR33	
KR45H	
KR46	
KR55	
KR65	

QZ specification ④ can be selected on the following models.

SKR33 (→ **A2-38**)

SKR46 (→ **A2-46**)

KR33 (→ **A2-158**)

KR46 (→ **A2-174**)

KR55 (→ **A2-182**)

KR65 (→ **A2-188**)

*It cannot be selected for SKR20, SKR26, SKR55, SKR65, KR15, KR20, KR26, KR30H and KR45H.

If QZ, QZA, QZB, or QZAD is selected for QZ specification ④, specify a stroke incorporating QZ.

(→ **A2-65**, **A2-193**)

If "2: with a bellows" has been selected for Cover ⑧, specify a stroke incorporating the bellows.

(→ **A2-76**, **A2-204**)

The available ball screw leads differ depending on the model.

SKR20: "01," "06"

SKR26: "02," "06"

SKR33: "06," "10," "20" (20 mm available for inner block A and B only)

SKR46: "10," "20"

SKR55: "20," "30," "40"

SKR65: "20," "25," "30," "50"

KR15: "01," "02"

KR20: "01," "06"

KR26: "02," "06"

KR30H: "06," "10"

KR33: "06," "10"

KR45H: "10," "20"

KR46: "10," "20"

KR55: "20"

KR65: "25"

	With/without a motor		Cover	Sensor	Housing A/ Intermediate flange
	0	-	1	B	AQ
	⑦		⑧	⑨	⑩

With direct coupling
0: Direct coupling (without motor)
1: Direct coupling (THK will purchase and mount the motor you specify)
With motor wrap
R1: Non-standard side wrap (without motor)
R2: Standard side wrap (without motor)
R3: Bottom side wrap (without motor)
R4: Non-standard side wrap (THK will purchase and mount the motor you specify)
R5: Standard side wrap (THK will purchase and mount the motor you specify)
R6: Bottom side wrap (THK will purchase and mount the motor you specify)

0: Without cover
1: With cover
2: With bellows

0: None
1
2
6
7
B
E
H
L
J
M

With direct coupling	With motor wrap
A0	WN-05D
AN	WP-08D
AP	WP-08K
AQ	WP-08M
AR	WQ-08D
AS	WQ-08K
AT	WQ-08M
AU	WV-14M
AV	WY-11M
AY	WY-14M
AZ	WZ-16M
A5	WZ-19M
A6	W5-19M
10	
20	
30	
40	
60	

If QZ specification ④ "QZ," "QZA," "QZB," or "QZAD" is selected, "2: With bellows" cannot be selected.

10, 30, and 40 are only available for the KR.

If "0" is selected:

No coupling will be attached. Please specify if a coupling is required when ordering.

If "R1," "R2," or "R3" is selected:

A timing pulley and timing belt will be included.

If "1," "R4," "R5," or "R6" is selected:

The designated motor will be mounted. Please specify the motor cable direction separately.

Please select an option for ⑩ Housing A/Intermediate flange that matches the specified motor.

This product is compatible with motors from various manufacturers. Contact THK for details.

⑦ Motor wrap direction

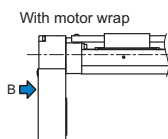
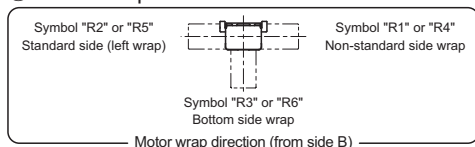

Precautions on Use

LM Guide Actuator

[Handling]

- (1) Do not disassemble the parts. This will result in loss of functionality.
- (2) Take care not to drop or strike the parts. Doing so may cause injury or damage. Striking it could also cause damage to its function even if the product looks intact.
- (3) When handling the product, wear protective gloves, safety shoes, etc. as necessary to ensure safety.

[Precautions on Use]

- (1) Prevent foreign material, such as cutting chips or coolant, from entering the product. Failure to do so may cause damage.
- (2) If the product is used in an environment where cutting chips, coolant, corrosive solvents, water, etc. may enter the product, use bellows, covers, etc. to prevent them from entering the product.
- (3) If foreign material such as cutting chips adheres to the product, replenish the lubricant after cleaning the product.
- (4) The service temperature range of this product is 0 to 40°C (no freezing or condensation). If you consider using this product outside the service temperature range, contact THK.
- (5) Exceeding the critical velocity may lead the components to be damaged or cause an accident. Be sure to use the product within the specification range designated by THK.
- (6) Very small strokes can inhibit the formation of an oil film between the raceways and the area of contact for the rolling elements, resulting in fretting. Therefore, be sure to use a type of grease with high fretting resistance properties if the stroke will be small. It is also recommended that a stroke movement corresponding to the length of the nut block be made on a regular basis to make sure an oil film is formed between the raceway and rolling element.
- (7) Do not use undue force when inserting parts (a pin, key, etc.) into the product. This may permanently deform the raceway, leading to loss of functionality.
- (8) If the product is operating or in the ready state, do not touch any moving parts. In addition, do not enter the operating area of the actuator.
- (9) If performing a task involving multiple people, confirm how to perform the work, what signals will be used, and how to handle problems before beginning, and assign another person to monitor the work.
- (10) Insufficient rigidity or accuracy of mounting members causes the bearing load to concentrate on one point, and the bearing performance will drop significantly. Accordingly, give sufficient consideration to the rigidity/accuracy of the housing and base and strength of the fixing bolts.
- (11) In applications where this product will be moved or transferred, the conditions of use may cause inertia from the motor's mass to result in damage to the motor attachment (Housing A) or other parts. Please contact THK before using in this manner.

[Lubrication]

- (1) Thoroughly wipe off the anti-rust oil before using the product.
- (2) Lubrication is needed to let the models SKR/KR demonstrate their functions fully. Using the product without sufficient lubrication may increase wear of the rolling elements or shorten the service life. Note the standard grease used in the product as follows.

Model KR15	THK AFF Grease
Models SKR20, SKR26, KR20, KR26	THK AFA Grease
Models SKR33, SKR46, SKR55, SKR65, KR30H, KR33, KR45H, KR46, KR55, KR65	THK AFB-LF Grease

- (3) Do not mix different lubricants. Mixing greases using the same type of thickening agent may still cause adverse interaction between the two greases if they use different additives, etc.
- (4) When using the product in locations exposed to constant vibrations or in special environments such as clean rooms, vacuum and low/high temperatures, use the grease appropriate for the specification/environment.
- (5) When adopting oil lubrication method, contact THK.
- (6) Because the intervals between greasing vary depending on the conditions of product use, it is recommended that the greasing interval be determined through an initial inspection. Although the lubrication interval may vary according to use conditions and the service environment, lubrication should be performed approximately every 100 km in travel distance (three to six months). Set the final lubrication interval/amount based on the actual machine.
- (7) The consistency of grease changes according to the temperature. Take note that the slide resistance of the models SKR/KR also changes as the consistency of grease changes.
- (8) After lubrication, the slide resistance of the models SKR/KR may increase due to the agitation resistance of grease. Be sure to perform a break-in operation to let the grease spread fully before operating the machine.
- (9) Excess grease may spatter immediately after lubrication, so wipe off spattered grease as necessary.
- (10) The properties of grease deteriorate and its lubrication performance drops over time, so grease must be checked and added properly according to the machine's frequency of use.

[Storage]

When storing the models SKR/KR, enclose them in a package designated by THK and store them in a room in a horizontal orientation while avoiding high temperatures, low temperatures, and high humidity.

After the product has been in storage for an extended period of time, the lubricant inside may have deteriorated, so add new lubricant before use.

[Disposal]

Dispose of the product properly as industrial waste.

[Instruction Manual]

You can download the "LM Guide Actuator Models SKR/KR -- Instruction Manual" from the THK technical support website.

Technical support website: <https://tech.thk.com/>



LM Guide Actuator

THK General Catalog

LM Guide Actuator

THK General Catalog

B Support Book

Features	B 2-6
Features of the LM Guide Actuator.....	B 2-6
• Structure and Features	B 2-6
• Caged Ball Technology (SKR).....	B 2-8
• Types and Configurations	B 2-9
Point of Selection	B 2-11
Static Safety Factor	B 2-11
Service Life	B 2-12
Example of Calculating the Nominal Life ..	B 2-15
Options	B 2-24
QZ Lubricator.....	B 2-25
Cover	B 2-25
Bellows	B 2-26
Sensor	B 2-26
XY Bracket (for Reference)	B 2-27
Model No.	B 2-28
Precautions on Use	B 2-30

A Product Descriptions (Separate)

Caged Ball LM Guide Actuator Model SKR .. A2-4

- Structure and Features A2-4
- Caged Ball Technology A2-6
- Types and Configurations..... A2-9
- Load Ratings in All Directions and Static Permissible Moment .. A2-11
- Maximum Speeds with Different Strokes .. A2-16
- Lubrication A2-18
- Static Safety Factor..... A2-19
- Service Life..... A2-20
- Accuracy Standards A2-24
- Model Number Coding..... A2-28

Dimensional Drawing, Dimensional Table

SKR20 Without Cover, Direct Motor Coupling ..	A2-30
SKR20 With Cover, Direct Motor Coupling ..	A2-31
SKR20 Without Cover, Motor Wrap.....	A2-32
SKR20 With Cover, Motor Wrap.....	A2-33
SKR26 Without Cover, Direct Motor Coupling..	A2-34
SKR26 With Cover, Direct Motor Coupling ..	A2-35
SKR26 Without Cover, Motor Wrap.....	A2-36
SKR26 With Cover, Motor Wrap.....	A2-37
SKR33 Without Cover, Direct Motor Coupling..	A2-38
SKR33 With Cover, Direct Motor Coupling ..	A2-39
SKR33 Without Cover, Motor Wrap.....	A2-40
SKR33 With Cover, Motor Wrap.....	A2-41
SKR33 Without Cover, Direct Motor Coupling..	A2-42
SKR33 With Cover, Direct Motor Coupling ..	A2-43
SKR33 Without Cover, Motor Wrap.....	A2-44
SKR33 With Cover, Motor Wrap.....	A2-45
SKR46 Without Cover, Direct Motor Coupling..	A2-46
SKR46 With Cover, Direct Motor Coupling ..	A2-47
SKR46 Without Cover, Motor Wrap.....	A2-48
SKR46 With Cover, Motor Wrap.....	A2-49
SKR46 Without Cover, Direct Motor Coupling..	A2-50
SKR46 With Cover, Direct Motor Coupling ..	A2-51
SKR46 Without Cover, Motor Wrap.....	A2-52
SKR46 With Cover, Motor Wrap.....	A2-53
SKR55 Without Cover, Direct Motor Coupling..	A2-54
SKR55 With Cover, Direct Motor Coupling ..	A2-55
SKR55 Without Cover, Motor Wrap	
Motor Flange Angle, 60×60	A2-56
SKR55 With Cover, Motor Wrap	
Motor Flange Angle, 60×60	A2-57
SKR55 Without Cover, Motor Wrap	
Motor Flange Angle, 80×80	A2-58
SKR55 With Cover, Motor Wrap	
Motor Flange Angle, 80×80	A2-59
SKR65 Without Cover, Direct Motor Coupling..	A2-60
SKR65 With Cover, Direct Motor Coupling ..	A2-61

SKR65 Without Cover, Motor Wrap.....	A2-62
--------------------------------------	-------

SKR65 With Cover, Motor Wrap.....	A2-63
-----------------------------------	-------

- Mass of Moving Elements A2-64

Options A2-65

QZ Lubricator.....	A2-65
Bellows.....	A2-76
Sensor.....	A2-81
Intermediate Flange (Direct Coupling)...	A2-85
Intermediate Flange (Motor Wrap).....	A2-89

LM Guide Actuator Model KR..... A2-112

- Structure and Features A2-112
- Types and Configurations..... A2-116
- Load Ratings in All Directions and Static Permissible Moment .. A2-118
- Maximum Speeds with Different Strokes .. A2-124
- Lubrication A2-126
- Static Safety Factor..... A2-127
- Service Life..... A2-128
- Accuracy Standards A2-132
- Model Number Coding..... A2-136

Dimensional Drawing, Dimensional Table

KR15 Without Cover, Direct Motor Coupling ..	A2-138
KR15 With Cover, Direct Motor Coupling ..	A2-139
KR15 Without Cover, Motor Wrap	A2-140
KR15 With Cover, Motor Wrap	A2-141
KR20 Without Cover, Direct Motor Coupling ..	A2-142
KR20 With Cover, Direct Motor Coupling ..	A2-143
KR20 Without Cover, Motor Wrap	A2-144
KR20 With Cover, Motor Wrap	A2-145
KR26 Without Cover, Direct Motor Coupling ..	A2-146
KR26 With Cover, Direct Motor Coupling ..	A2-147
KR26 Without Cover, Motor Wrap	A2-148
KR26 With Cover, Motor Wrap	A2-149
KR30H Without Cover, Direct Motor Coupling ..	A2-150
KR30H With Cover, Direct Motor Coupling ..	A2-151
KR30H Without Cover, Motor Wrap.....	A2-152
KR30H With Cover, Motor Wrap.....	A2-153
KR30H Without Cover, Direct Motor Coupling ..	A2-154
KR30H With Cover, Direct Motor Coupling ..	A2-155
KR30H Without Cover, Motor Wrap.....	A2-156
KR30H With Cover, Motor Wrap.....	A2-157
KR33 Without Cover, Direct Motor Coupling ..	A2-158
KR33 With Cover, Direct Motor Coupling ..	A2-159
KR33 Without Cover, Motor Wrap	A2-160
KR33 With Cover, Motor Wrap	A2-161
KR33 Without Cover, Direct Motor Coupling ..	A2-162
KR33 With Cover, Direct Motor Coupling ..	A2-163

KR33 Without Cover, Motor Wrap	A2-164
KR33 With Cover, Motor Wrap	A2-165
KR45H Without Cover, Direct Motor Coupling ..	A2-166
KR45H With Cover, Direct Motor Coupling ..	A2-167
KR45H Without Cover, Motor Wrap	A2-168
KR45H With Cover, Motor Wrap	A2-169
KR45H Without Cover, Direct Motor Coupling ..	A2-170
KR45H With Cover, Direct Motor Coupling ..	A2-171
KR45H Without Cover, Motor Wrap	A2-172
KR45H With Cover, Motor Wrap	A2-173
KR46 Without Cover, Direct Motor Coupling	A2-174
KR46 With Cover, Direct Motor Coupling	A2-175
KR46 Without Cover, Motor Wrap	A2-176
KR46 With Cover, Motor Wrap	A2-177
KR46 Without Cover, Direct Motor Coupling ..	A2-178
KR46 With Cover, Direct Motor Coupling ..	A2-179
KR46 Without Cover, Motor Wrap	A2-180
KR46 With Cover, Motor Wrap	A2-181
KR55 Without Cover, Direct Motor Coupling ..	A2-182
KR55 With Cover, Direct Motor Coupling ..	A2-183
KR55 Without Cover, Motor Wrap	
Motor Flange Angle, 60×60	A2-184
KR55 With Cover, Motor Wrap	
Motor Flange Angle, 60×60	A2-185
KR55 Without Cover, Motor Wrap	
Motor Flange Angle, 80×80	A2-186
KR55 With Cover, Motor Wrap	
Motor Flange Angle, 80×80	A2-187
KR65 Without Cover, Direct Motor Coupling ..	A2-188
KR65 With Cover, Direct Motor Coupling ..	A2-189
KR65 Without Cover, Motor Wrap	A2-190
KR65 With Cover, Motor Wrap	A2-191
• Mass of Moving Elements	A2-192
Options	A2-193
QZ Lubricator	A2-193
Bellows	A2-204
Sensor	A2-210
Intermediate Flange (Direct Coupling) ..	A2-214
Intermediate Flange (Motor Wrap)	A2-218
XY Bracket (for Reference)	A2-248
Model No.	A2-252
Precautions on Use	A2-254

Features of the LM Guide Actuator

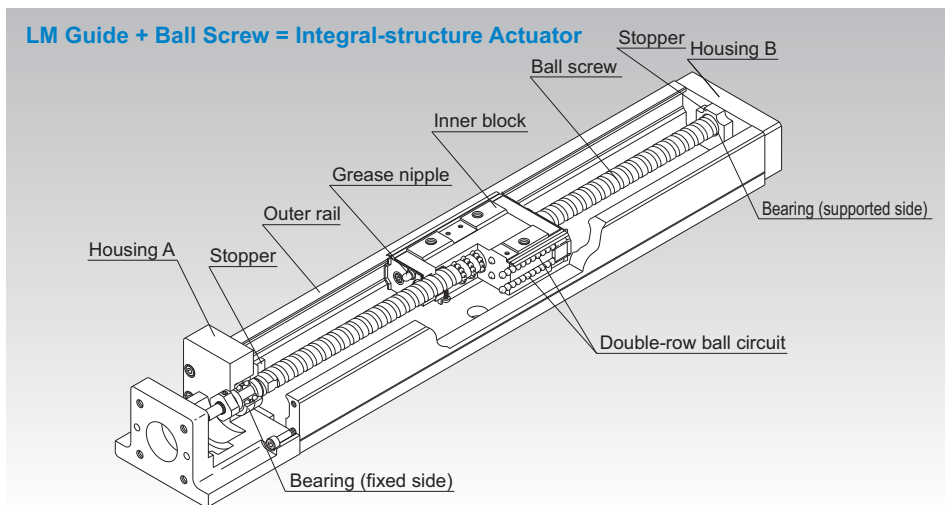

Fig.1 Structure of LM Guide Actuator Model KR

Structure and Features

Because of its integral-structure inner block consisting of a highly rigid outer rail with a U-shaped cross section, LM Guide units on both side faces and a Ball Screw unit in the center, the LM Guide Actuator model SKR/KR achieves a highly rigid and highly accurate actuator in a minimal space. In addition, since the housings A and B also serve as support units and the inner block as a table, this model allows significant reduction of man-hours required for design and assembly, thus contributing to total cost cutting.

By using ball cages in the LM Guide unit and the Ball Screw unit, model SKR achieves higher speed operation, lower noise, longer-term maintenance-free operation, etc. than the previous model KR (a ball cage is used only for the LM Guide unit of models SKR20 and SKR26 and their Ball Screw units are fitted with QZ Lubricator).

Features

Features of the LM Guide Actuator

[4-way Equal Load]

Each row of balls is arranged at a contact angle of 45° so that the rated load on the inner block is uniform under loads applied to the inner block in the four directions (radial, reverse radial and lateral directions). As a result, model KR can be used in any mounting orientation.

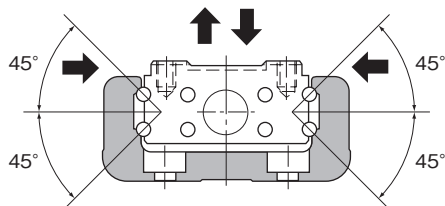

Fig.2 Load Capacity and Contact Angle of Model SKR/KR

[High Accuracy]

Since the linear guide consists of four rows of balls to smoothly move with two points of contact even under a preload, a highly rigid guide with no clearance is achieved. Additionally, variation in frictional resistance caused by load fluctuation is minimized, allowing highly accurate feeding. The system contributes significantly to increasing precision and quality by providing precision-grade positioning performance to all kinds of machines.

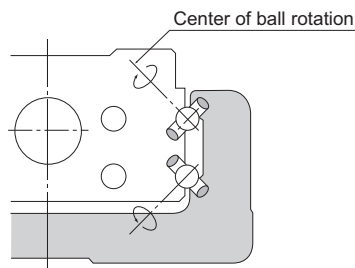

Fig.3 Contact Structure of Model SKR/KR

[High Rigidity]

Use of an outer rail with a U-shaped cross section increases the rigidity against a moment and torsion.

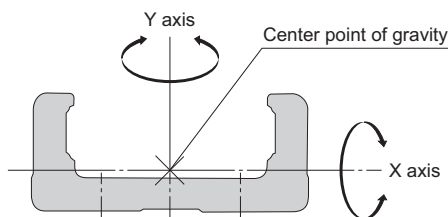

Fig.4 Cross Section of the Outer Rail

Table1 Cross-sectional Characteristics of the Outer rail Rail

Model No.	I_x [mm ⁴]	I_y [mm ⁴]	Mass[kg/m]
SKR20	6.0×10^3	6.14×10^4	2.6
SKR26	1.66×10^4	1.48×10^5	3.9
SKR33	5.35×10^4	3.52×10^5	6.1
SKR46	2.05×10^5	1.45×10^6	12.6
SKR55	2.07×10^5	2.09×10^6	13.2
SKR65	4.51×10^5	5.73×10^6	22.1
KR15	9.08×10^2	1.42×10^4	1.04
KR20	6.1×10^3	6.2×10^4	2.6
KR26	1.7×10^4	1.5×10^5	3.9
KR30H	2.7×10^4	2.8×10^5	5.0
KR33	6.2×10^4	3.8×10^5	6.6
KR45H	8.4×10^4	8.9×10^5	9.0
KR46	2.4×10^5	1.5×10^6	12.6
KR55	2.2×10^5	2.3×10^6	15.0
KR65	4.6×10^5	5.9×10^6	23.1

I_x =geometrical moment of inertia around X axis

I_y =geometrical moment of inertia around Y axis

Caged Ball Technology (SKR)

[High Lubricity]

Model SKR uses ball cages to eliminate friction between balls and significantly improve torque characteristics. As a result, the torque fluctuation is reduced and superb lubricity is achieved.

Item	Description
Shaft diameter/lead	$\phi 13/10$ mm
Shaft rotation speed	60 min ⁻¹

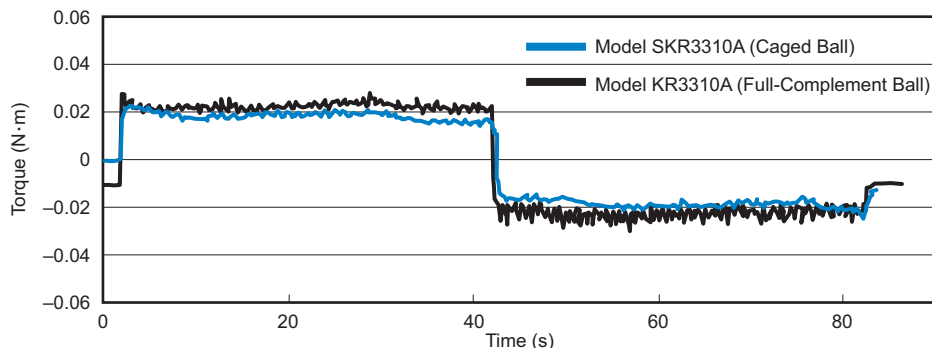

Fig.5 Comparison of Torque Fluctuation between Model SKR and Model KR

[Low Noise, Acceptable Running Sound]

In model SKR, the use of a ball cage in the LM Guide section and Ball Screw section (excluding models SKR20/26) has eliminated collision noise between the balls. As a result, low noise and acceptable running sound are achieved.

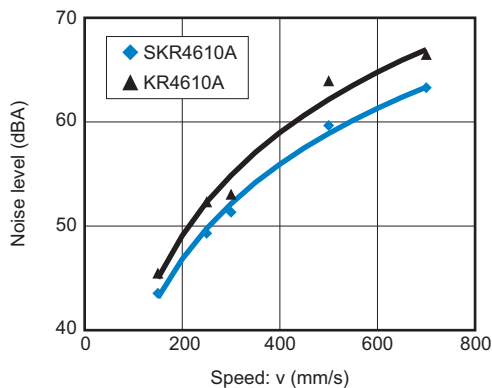

Fig.6 Comparison of Noise between Model SKR4610A and Model KR4610A

Types and Configurations

[Types]

SKR/KR-A (with a Single Long Block)

These are representative models for SKR/KR.

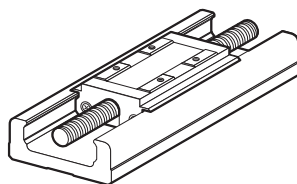

SKR/KR-B (with Two Long Blocks)

These models use two A type inner blocks to achieve high rigidity and high load capacity.

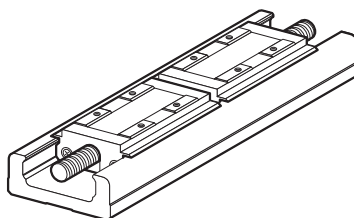

SKR/KR-C (with a Single Short Block)

These models use an A type block with a shortened overall length to extend the stroke.

(Applicable models: SKR33,* 46, KR30H, 33, 45H, 46)

* There are no short blocks for SKR3320.

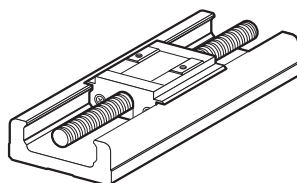

SKR/KR-D (with Two Short Blocks)

These models use two C type inner blocks, and the distance between blocks can be adjusted to the device, allowing for high rigidity.

(Applicable models: SKR33,* 46, KR30H, 33, 45H, 46)

* There are no short blocks for SKR3320.

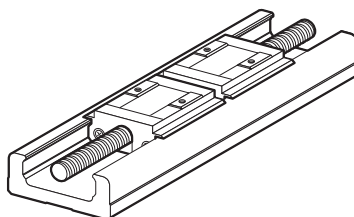

[Configurations]

SKR/KR direct motor coupling (without cover)

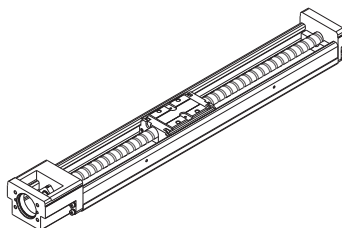

SKR/KR direct motor coupling (with cover)

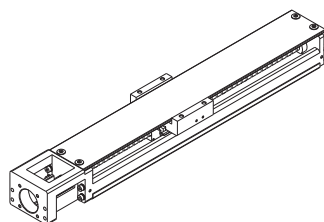

SKR/KR motor wrap (without cover)

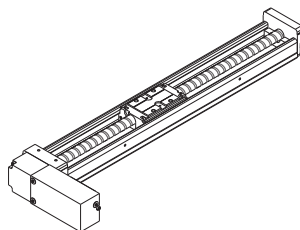

SKR/KR motor wrap (with cover)

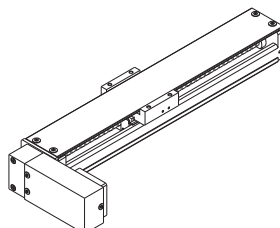

Static Safety Factor

[Calculating the Static Safety Factor]

● LM Guide Unit

To calculate a load applied to the LM Guide of model SKR/KR, the average load required for calculating the service life and the maximum load needed for calculating the static safety factor must be obtained first. In particular, if the system starts and stops frequently, or if a large moment caused by an overhung load is applied to the system, it may receive an unexpectedly large load.

When selecting a model number, make sure that the desired model is capable of receiving the required maximum load (whether stationary or in motion).

$$f_s = \frac{C_0}{P_{\max}}$$

f_s : Static safety factor

C_0 : Basic static load rating (N)

P_{\max} : Maximum applied load (N)

*The basic static load rating is a static load with a constant direction and magnitude whereby the sum of the permanent deformation of the rolling element and that of the raceway on the contact area under the maximum stress is 0.0001 times the rolling element diameter.

● Ball Screw Unit/Bearing Unit(Fixed Side)

If an unexpected external force is applied in the axial direction as a result of an inertia caused by an impact or start and stop while model SKR/KR is stationary or operating, it is necessary to take into account the static safety factor.

$$f_s = \frac{C_{0a}}{F_{\max}}$$

f_s : Static safety factor

C_{0a} : Basic static load rating (N)

F_{\max} : Maximum applied load (N)

[Standard Values for the Static Safety Factor (f_s)]

Machine type	Load conditions	Minimum Static Safety Factor (f_s)
General industrial machinery	Without vibration or impact	1.0 to 3.5
	With vibration or impact	2.0 to 5.0

*The standard value of the static safety factor may vary depending on the load conditions as well as environment, lubrication status, mounting accuracy, and/or rigidity.

Service Life

Model SKR/KR consists of an LM Guide, a Ball Screw and a support bearing. The nominal life of each component can be obtained using the basic dynamic load rating indicated in **A2-12Table4** and **A2-120Table3** (Rated Load of Model KR).

[LM Guide Unit]

● Nominal Life

■ Calculating the Nominal Life

The nominal life (L_{10}) of an LM Guide with balls is obtained from the following formula using the basic dynamic load rating (C), which is based on a reference distance of 50 km, and the calculated load acting on the LM Guide (P_c).

- LM Guide with balls (Using a basic dynamic load rating based on a nominal life of 50 km)

$$L_{10} = \left(\frac{C}{P_c} \right)^3 \times 50 \dots\dots\dots (1)$$

L_{10}	: Nominal life	(km)
C	: Basic dynamic load rating	(N)
P_c	: Calculated load	(N)

*These nominal life formulas may not apply if the length of the stroke is less than or equal to twice the length of the LM block.

When comparing the nominal life (L_{10}), you must take into account whether the basic dynamic load rating was defined based on 50 km or 100 km. Convert the basic dynamic load rating based on ISO 14728-1 as necessary.

ISO-regulated basic dynamic load rating conversion formula:

- LM Guide with balls

$$C_{100} = \frac{C_{50}}{1.26}$$

C_{50}	: Basic dynamic load rating based on a nominal life of 50 km
C_{100}	: Basic dynamic load rating based on a nominal life of 100 km

■ Calculating the Modified Nominal Life

During use, an LM Guide may be subjected to vibrations and shocks as well as fluctuating loads, which are difficult to detect. In addition, having LM blocks arranged directly behind one another will have a decisive impact on the service life. Taking these factors into account, the modified nominal life (L_{10m}) can be calculated according to the following formula (2).

● Modified factor α

$$\alpha = \frac{f_c}{f_w}$$

α	: Modified factor	
f_c	: Contact factor	(see Table1 on B2-14)
f_w	: Load factor	(see Table2 on B2-14)

● Modified nominal life L_{10m}

- LM Guide with balls

$$L_{10m} = \left(\alpha \times \frac{C}{P_c} \right)^3 \times 50 \dots\dots\dots (2)$$

L_{10m}	: Modified nominal life	(km)
C	: Basic dynamic load rating	(N)
P_c	: Calculated load	(N)

Point of Selection

Service Life

- If a moment is applied to model SKR-B/D or KR-B/D using two inner blocks in close contact with each other, calculate the equivalent load by multiplying the applied moment by the equivalent factor indicated in **A2-23**Table10 and **A2-131**Table9.

$$P_m = K \cdot M$$

- P_m : Equivalent load (per inner block) (N)
 K : Equivalent moment factor
 (see **A2-23**Table10 and **A2-131**Table9)
 M : Applied moment (N·mm)
 (If planning to use with a wide inner block span, contact THK.)

- If moment M_c is applied to model SKR-B/D or KR-B/D

$$P_m = \frac{K_c \cdot M_c}{2}$$

- If a radial load (P) and a moment are simultaneously applied to model SKR/KR

$$P_E = P_m + P$$

- P_E : Total equivalent radial load (N)
 Perform a nominal life calculation using the above data.

● Service Life Time

When the nominal life (L_{10}) has been obtained, the service life time is obtained using the following equation (if the stroke length and the number of reciprocations per minute are constant).

$$L_h = \frac{L_{10} \times 10^6}{2 \cdot \ell_s \cdot n_1 \times 60}$$

- L_h : Service life time (h)
 ℓ_s : Stroke length (mm)
 n_1 : Number of reciprocations per minute (min^{-1})

[Ball Screw Unit/Bearing Unit(Fixed Side)]

● Nominal Life

■ Calculating the Nominal Life

The nominal life (L_{10}) is obtained from the following equation using the basic dynamic load rating (C_a) and the load acting on the ball screw in the axial direction (F_a).

$$L_{10} = \left(\frac{C_a}{F_a} \right)^3 \times 10^6 \dots\dots\dots(1)$$

- L_{10} : Nominal life (rev.)
 C_a : Basic dynamic load rating (N)
 F_a : Axial load (N)

■ Calculating the Modified Nominal Life

During use, a ball screw may be subjected to vibrations and shocks as well as fluctuating loads, which are difficult to detect. Taking these factors into account, the modified nominal life (L_{10m}) can be calculated according to the following formula (2).

- Modified factor α

$$\alpha = \frac{1}{f_w}$$

α : Modified factor
 f_w : Load factor (see Table2)

- Modified nominal life L_{10m}

$$L_{10m} = \left(\alpha \times \frac{C_a}{F_a} \right)^3 \times 10^6 \dots\dots\dots(2)$$

L_{10m} : Modified nominal life (rev.)
 α : Modified factor
 C_a : Basic dynamic load rating (N)
 F_a : Axial load (N)

● Service Life Time

When the nominal life (L_{10}) has been obtained, the service life time is obtained using the following equation (if the stroke length and the number of reciprocations per minute are constant).

$$L_h = \frac{L_{10} \cdot \ell}{2 \cdot \ell_s \cdot n_1 \times 60}$$

L_h : Service life time (h)
 ℓ_s : Stroke length (mm)
 n_1 : Number of reciprocations per minute (min^{-1})
 ℓ : Ball screw lead (mm)

■ f_c : Contact Factor

If two inner blocks are used in close contact with each other with models SKR-B/D and KR-B/D, multiply the basic load rating by the corresponding contact factor indicated in Table1.

Table1 Contact Factor (f_c)

Inner block types	Contact factor f_c
Model SKR, KR-B Model SKR, KR-D	0.81

■ f_w : Load Factor

Table2 shows load factors.

Table2 Load Factor (f_w)

Vibrations/impact	Speed(V)	f_w
Faint	Very low $V \leq 0.25\text{m/s}$	1 to 1.2
Weak	Slow $0.25 < V \leq 1\text{m/s}$	1.2 to 1.5
Medium	Medium $1 < V \leq 2\text{m/s}$	1.5 to 2
Strong	High $V > 2\text{m/s}$	2 to 3.5

■ K : Moment Equivalent Factor (LM Guide Unit)

When the product travels under a moment, the distribution of load applied to the LM Guide is locally large (see **A1-40**). In such cases, calculate the load by multiplying the moment value by the corresponding moment equivalent factor indicated in **A2-23**Table10 and **A2-131**Table9.

Symbols K_A , K_B and K_C indicate the moment equivalent loads in the M_A , M_B and M_C directions, respectively.

Example of Calculating the Nominal Life

[Condition (Horizontal Installation)]

Assumed model number	: KR 5520A
LM Guide unit	($C = 38100 \text{ N}$, $C_o = 61900 \text{ N}$)
Ball Screw unit	($C_a = 3620 \text{ N}$, $C_{oa} = 9290 \text{ N}$)
Bearing unit(Fixed Side)	($C_a = 7600 \text{ N}$, $P_{oa} = 3990 \text{ N}$)
Mass	: $m = 30 \text{ kg}$
Speed	: $v = 500 \text{ mm/s}$
Acceleration	: $\alpha = 2.4 \text{ m/s}^2$
Stroke	: $l_s = 1200 \text{ mm}$
Gravitational acceleration	: $g = 9.807 \text{ m/s}^2$
Velocity diagram	: see Fig.1

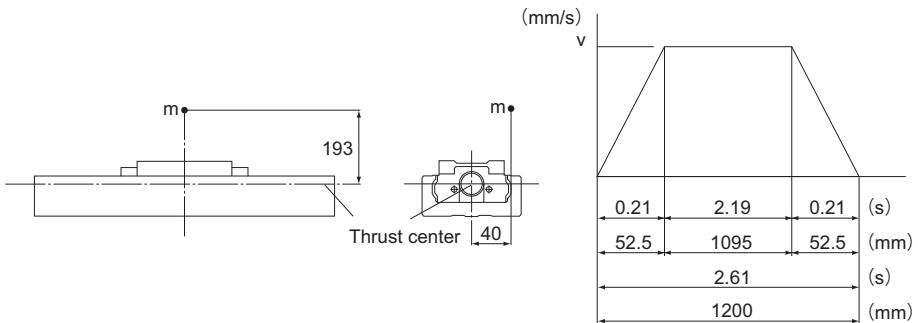

Fig.1 Velocity Diagram

[Consideration]

● Studying the LM Guide Unit

■ Load Applied to the Inner Block

* Assuming that a single inner block is used, convert applied moments M_A and M_B into applied load by multiplying them by the moment equivalent factor ($K_A = K_B = 8.63 \times 10^{-2}$).

* Assuming that a single shaft is used, convert applied moment M_C into applied load by multiplying it by the moment equivalent factor ($K_C = 2.83 \times 10^{-2}$).

- During uniform motion:

$$P_1 = mg + K_C \cdot mg \times 40 = 627 \text{ N}$$

- During acceleration:

$$P_{1a} = P_1 + K_A \cdot m\alpha \times 40 = 1826 \text{ N}$$

$$P_{1aT} = -K_B \cdot m\alpha \times 40 = -249 \text{ N}$$

- During deceleration:

$$P_{1d} = P_1 - K_A \cdot m\alpha \times 40 = -572 \text{ N}$$

$$P_{1dT} = K_B \cdot m\alpha \times 40 = 249 \text{ N}$$

* Since the groove under a load is different from the assumed groove, give "0" (zero) to P_{1aT} and P_{1d} .

■ Combined Radial And Thrust Load

- During uniform motion:

$$P_{1E} = P_1 = 627 \text{ N}$$

- During acceleration:

$$P_{1aE} = P_{1a} + P_{1aT} = 1826 \text{ N}$$

- During deceleration:

$$P_{1dE} = P_{1d} + P_{1dT} = 249 \text{ N}$$

■ Static Safety Factor

$$f_s = \frac{C_0}{P_{\max}} = \frac{C_0}{P_{1aE}} = 33.9$$

■ Nominal Life

- Average load

$$P_m = \sqrt[3]{\frac{1}{\ell_s} (P_{1E}^3 \times 1095 + P_{1aE}^3 \times 52.5 + P_{1dE}^3 \times 52.5)} = 790 \text{ N}$$

- Nominal life

$$L_{10m} = \left(\alpha \times \frac{C}{P_m} \right)^3 \times 50 = 3.25 \times 10^6 \text{ km}$$

$$\alpha = \frac{1}{f_w}$$

f_w : Load factor (1.2)

● Studying the Ball Screw Unit

■ Axial load

- During forward uniform motion:

$$F_{a1} = \mu \cdot mg + f = 11 \text{ N}$$

μ : Friction coefficient(0.005)

f : Rolling resistance of one KR inner block + seal resistance(10.0 N)

- During forward acceleration:

$$F_{a2} = F_{a1} + m\alpha = 83 \text{ N}$$

- During forward deceleration:

$$F_{a3} = F_{a1} - m\alpha = -61 \text{ N}$$

- During uniform backward motion

$$F_{a4} = -F_{a1} = -11 \text{ N}$$

- During backward acceleration:

$$F_{a5} = F_{a4} - m\alpha = -83 \text{ N}$$

- During backward deceleration:

$$F_{a6} = F_{a4} + m\alpha = 61 \text{ N}$$

* Since the groove under a load is different from the assumed groove, give "0" (zero) to F_{a3} , F_{a4} and F_{a5} .

■ Static Safety Factor

$$f_s = \frac{C_{0a}}{F_{amax}} = \frac{C_{0a}}{F_{a2}} = 111.9$$

■ Buckling Load

$$P_1 = \frac{n \cdot \pi^2 \cdot E \cdot I}{l_a^2} \times 0.5 = 11000 \text{ N}$$

P_1 : Buckling load (N)

l_a : Distance between two mounting surfaces (1300 mm)

E : Young's modulus ($2.06 \times 10^5 \text{ N/mm}^2$)

n : Factor for mounting method (fixed-fixed: 4.0, see **A15-30**)

0.5 : Safety factor

I : Minimum geometrical moment of inertia of the shaft (mm^4)

$$I = \frac{\pi}{64} \cdot d_1^4$$

d_1 : Screw-shaft thread minor diameter (17.5 mm)

■ Permissible tensile Compressive Load

$$P_2 = \delta \cdot \frac{\pi}{4} \cdot d_1^2 = 35300 \text{ N}$$

P_2 : Permissible tensile compressive load (N)

δ : Permissible tensile compressive stress (147 N/mm²)

d_1 : Screw-shaft thread minor diameter (17.5mm)

■ Dangerous Speed

$$N_1 = \frac{60 \cdot \lambda^2}{2\pi \cdot \ell_b^2} \cdot \sqrt{\frac{E \times 10^3 \cdot I}{\gamma \cdot A}} \times 0.8 = 1560 \text{ min}^{-1}$$

N_1 : Dangerous speed (min⁻¹)

ℓ_b : Distance between two mounting surfaces (1300mm)

γ : Density (7.85 × 10⁻⁶kg/mm³)

λ : Factor according to the mounting method (fixed-supported 3.927, see **A15-32**)

0.8 : Safety factor

■ DN Value

$$DN = 31125 (\leq 50000)$$

D : Ball center-to-center diameter (20.75mm)

N : Maximum working rotation speed (1500min⁻¹)

■ Nominal Life

- Average axial load

$$F_{am} = \sqrt[3]{\frac{1}{2 \cdot \ell_s} (F_{a1}^3 \times 1095 + F_{a2}^3 \times 52.5 + F_{a6}^3 \times 52.5)} = 26.2 \text{ N}$$

- Nominal life

$$L_{10m} = \left(\frac{\alpha \cdot C_a}{F_{am}} \right)^3 \cdot \ell = 3.05 \times 10^7 \text{ km}$$

$$\alpha = \frac{1}{f_w}$$

f_w : Load factor (1.2)

ℓ : Ball screw lead (20 mm)

● **Bearing Unit (Fixed Side)**

■ **Axial Load (Same as the Ball Screw Unit)**

$$F_{a1} = 11 \text{ N}$$

$$F_{a2} = 83 \text{ N}$$

$$F_{a3} = 0 \text{ N}$$

$$F_{a4} = 0 \text{ N}$$

$$F_{a5} = 0 \text{ N}$$

$$F_{a6} = 61 \text{ N}$$

■ **Static Safety Factor**

$$f_s = \frac{P_{0a}}{F_{a\max}} = \frac{P_{0a}}{F_{a2}} = 48.0$$

■ **Nominal Life**

● Average axial load

$$F_{am} = \sqrt[3]{\frac{1}{2 \cdot \ell_s} (F_{a1}^3 \times 1095 + F_{a2}^3 \times 52.5 + F_{a6}^3 \times 52.5)} = 26.2 \text{ N}$$

● Nominal life

$$L_{10m} = \left(\alpha \times \frac{C_a}{F_{am}} \right)^3 \times 10^6 = 1.41 \times 10^{13} \text{ rev}$$

$$\alpha = \frac{1}{f_w}$$

$$f_w : \text{Load factor} \quad (1.2)$$

* Convert the above nominal life into the service life in travel distance of the Ball Screw.

$$L_s = L_{10m} \cdot \ell \times 10^{-6} = 2.82 \times 10^8 \text{ km}$$

[Result]

The table below shows the result of the examination.

KR5520A	LM guide unit	Ball screw unit	Bearing unit (Fixed side)
Static safety factor	33.9	111.9	48.0
Buckling load(N)	—	11000	—
Permissible tensile compressive load(N)	—	35300	—
Dangerous speed(min ⁻¹)	—	1560	—
DN Value	—	31125	—
Nominal life(km)	3.25×10^8	3.05×10^7	2.82×10^8
Maximum working rotation speed(min ⁻¹)	—	1500	—

Note1) From the static safety coefficient and other values above, it is judged that the assumed model can be used.

Note2) Of the rated lives of the three components, the shortest value (of LM Guide unit) is considered the nominal life of the assumed model KR 5520A.

[Condition (Vertical Installation)]

Assumed model number	: KR 5520A
LM Guide Unit	($C = 38100 \text{ N}$, $C_0 = 61900 \text{ N}$)
Ball Screw Unit	($C_a = 3620 \text{ N}$, $C_{0a} = 9290 \text{ N}$)
Bearing Unit(Fixed Side)	($C_a = 7600 \text{ N}$, $P_{0a} = 3990 \text{ N}$)
Mass	: $m = 30 \text{ kg}$
Speed	: $v = 500 \text{ mm/s}$
Acceleration	: $\alpha = 2.4 \text{ m/s}^2$
Stroke	: $l_s = 1200 \text{ mm}$
Gravitational acceleration	: $g = 9.807 \text{ m/s}^2$
Velocity diagram	see Fig.2

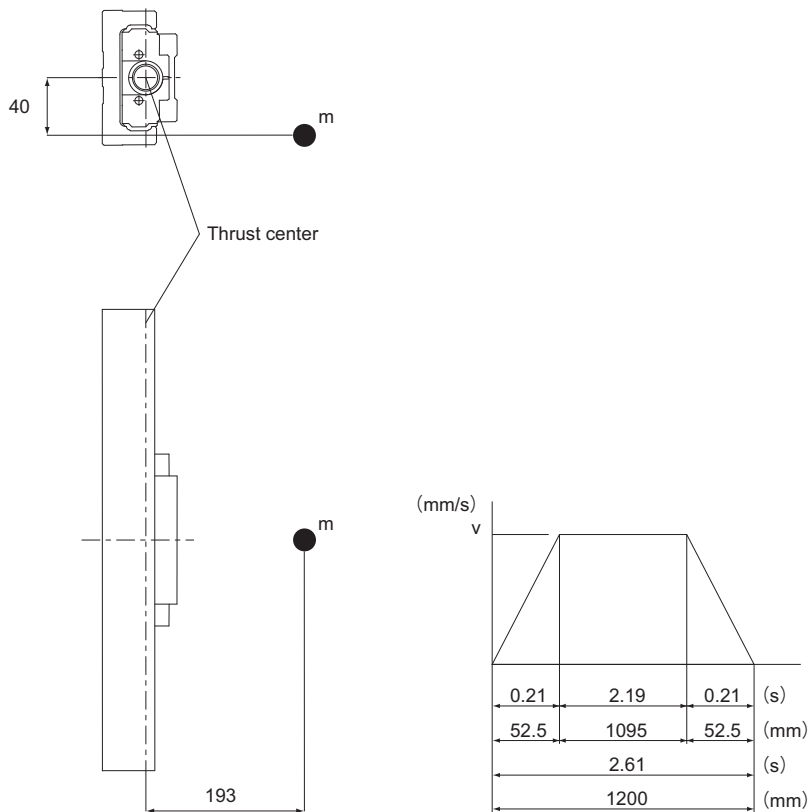

Fig.2 Velocity Diagram

[Consideration]● **Studying the LM Guide Unit**■ **Load Applied to the Inner Block**

* Assuming that a single inner block is used, convert applied moments M_A and M_B into applied load by multiplying them by the moment equivalent factor ($K_A = K_B = 8.63 \times 10^{-2}$).

- During uniform motion:

$$P_1 = K_A \cdot mg \times 193 = 4900 \text{ N}$$

$$P_{1T} = K_B \cdot mg \times 40 = 1016 \text{ N}$$

- During acceleration:

$$P_{1a} = P_1 + K_A \cdot m\alpha \times 193 = 6100 \text{ N}$$

$$P_{1aT} = P_{1T} + K_B \cdot m\alpha \times 40 = 1264 \text{ N}$$

- During deceleration:

$$P_{1d} = P_1 - K_A \cdot m\alpha \times 193 = 3701 \text{ N}$$

$$P_{1dT} = P_{1dT} - K_B \cdot m\alpha \times 40 = 767 \text{ N}$$

■ **Combined Radial And Thrust Load**

- During uniform motion:

$$P_{1E} = P_1 + P_{1T} = 5916 \text{ N}$$

- During acceleration:

$$P_{1aE} = P_{1a} + P_{1aT} = 7364 \text{ N}$$

- During deceleration:

$$P_{1dE} = P_{1d} + P_{1dT} = 4468 \text{ N}$$

■ **Static Safety Factor**

$$f_s = \frac{C_0}{P_{\max}} = \frac{C_0}{P_{1aE}} = 8.4$$

■ **Nominal Life**

- Average load

$$P_m = \sqrt[3]{\frac{1}{\ell_s} (P_{1E}^3 \times 1095 + P_{1aE}^3 \times 52.5 + P_{1dE}^3 \times 52.5)} = 5947 \text{ N}$$

- Nominal life

$$L_{10m} = \left(\alpha \times \frac{C}{P_m} \right)^3 \times 50 = 7.61 \times 10^3 \text{ km}$$

$$\alpha = \frac{1}{f_w}$$

$$f_w : \text{Load factor} \quad (1.2)$$

● Studying the Ball Screw Unit

■ Axial Load

- During upward uniform motion:
 $F_{a1} = mg + f = 304 \text{ N}$
 f : Sliding resistance per block (10.0 N)
- During upward acceleration:
 $F_{a2} = F_{a1} + m\alpha = 376 \text{ N}$
- During upward deceleration:
 $F_{a3} = F_{a1} - m\alpha = 232 \text{ N}$
- During downward uniform motion:
 $F_{a4} = mg - f = 284 \text{ N}$
- During downward acceleration:
 $F_{a5} = F_{a4} - m\alpha = 212 \text{ N}$
- During downward deceleration:
 $F_{a6} = F_{a4} + m\alpha = 356 \text{ N}$

■ Static Safety Factor

$$f_s = \frac{C_{0a}}{F_{\max}} = \frac{C_{0a}}{F_{a2}} = 24.7$$

■ Buckling Load

Same as Horizontal Installation

■ Permissible Tensile Compressive Load

Same as Horizontal Installation

■ Dangerous Speed

Same as Horizontal Installation

■ DN Value

Same as Horizontal Installation

■ Nominal Life

- Average axial load

$$F_m = \sqrt[3]{\frac{1}{2 \cdot \ell_s} (F_{a1}^3 \times 1095 + F_{a2}^3 \times 52.5 + F_{a3}^3 \times 52.5 + F_{a4}^3 \times 1095 + F_{a5}^3 \times 52.5 + F_{a6}^3 \times 52.5)} = 296 \text{ N}$$

- Nominal life

$$L_{10m} = \left(\alpha \times \frac{C_a}{F_{am}} \right)^3 \times \ell = 2.11 \times 10^4 \text{ km}$$

$$\alpha = \frac{1}{f_w}$$

f_w : Load factor (1.2) ℓ : Ball screw lead (20 mm)

● **Bearing Unit (Fixed Side)**

■ **Axial Load (Same as the Ball Screw Unit)**

$$F_{a1} = 304 \text{ N}$$

$$F_{a2} = 376 \text{ N}$$

$$F_{a3} = 232 \text{ N}$$

$$F_{a4} = 284 \text{ N}$$

$$F_{a5} = 212 \text{ N}$$

$$F_{a6} = 356 \text{ N}$$

■ **Static Safety Factor**

$$f_s = \frac{P_{0a}}{F_{\max}} = \frac{P_{0a}}{F_{a2}} = 10.6$$

■ **Nominal Life**

● **Average axial load**

$$F_m = \sqrt[3]{\frac{1}{2 \cdot \ell_s} (F_{a1}^3 \times 1095 + F_{a2}^3 \times 52.5 + F_{a3}^3 \times 52.5 + F_{a4}^3 \times 1095 + F_{a5}^3 \times 52.5 + F_{a6}^3 \times 52.5)} = 296 \text{ N}$$

● **Nominal life**

$$L_{10m} = \left(\alpha \times \frac{C_a}{F_{am}} \right)^3 \times \ell = 9.80 \times 10^9 \text{ rev}$$

$$\alpha = \frac{1}{f_w}$$

$$f_w : \text{Load factor} \quad (1.2)$$

* Convert the above nominal life into the service life in travel distance of the Ball Screw.

$$L_s = L_{10m} \cdot \ell \times 10^{-6} = 1.95 \times 10^5 \text{ km}$$

[Result]

The table below shows the result of the examination.

KR5520A	LM guide unit	Ball screw unit	Bearing unit (Fixed side)
Static safety factor	8.4	24.7	10.6
Buckling load(N)	—	11000	—
Permissible tensile compressive load(N)	—	35300	—
Dangerous speed(min ⁻¹)	—	1560	—
DN Value	—	31125	—
Nominal life(km)	7.61 × 10 ³	2.11 × 10 ⁴	1.95 × 10 ⁵
Maximum working rotation speed(min ⁻¹)	—	1500	—

Note1) From the static safety coefficient and other values above, it is judged that the assumed model can be used.

Note2) Of the rated lives of the three components, the shortest value (of LM Guide unit) is considered the nominal life of the assumed model KR 5520A.

Options

LM Guide Actuator (Options)

Various types of options are available for models SKR and KR. Select an appropriate model according to your application.

There are also options not contained in this catalog. Contact THK for details.

Name		Overview
QZ Lubricator		Significantly Extended Maintenance Interval
Cover	Cover	Serve as contamination protection accessories or the likes
	Bellows	
Sensor	Proximity sensor	Supporting manufacturers: Azbil Corp., Panasonic Industrial Devices SUNX Co., Ltd.
	Photo sensor	Supporting manufacturer: Omron
	Sensor rail	For mounting a sensor
Motor bracket	Housing A with a separate motor/ wrap-around housing	If the customer provides a motor bracket and a motor wrap-around section
	Intermediate Flange	Supporting manufacturers: Yaskawa Electric, Mitsubishi Electric, Panasonic, Sanyo Electric, Omron, Fanuc, Keyence and Oriental Motor

Table1 Table of Applicable Options

Model No.	QZ Lubricator	Cover	Bellows	Proximity sensor	Photo sensor	Housing A for a Separate Motor	Turnaround Housing A	Intermediate Flange
SKR20	— ^{*1}	○	○	○	○	—	△	○
SKR26	— ^{*1}	○	○	○	○	—	△	○
SKR33	○	○	○	○	○	—	△	○
SKR46	○	○	○	○	○	—	△	○
SKR55	—	○	○	○	○	—	○	○
SKR65	—	○	○	○	○	—	○	○
KR15	—	○	○	○	—	—	△	○
KR20	—	○	○	○	○	—	—	○
KR26	—	○	○	○	○	—	—	○
KR30H	—	○	○	○	○	—	△	○
KR33	○	○	○	○	○	○	○	○
KR45H	—	○	○	○	○	—	△	○
KR46	○	○	○	○	○	○	○	○
KR55	○	○	○	○	○	—	○	○
KR65	○	○	○	○	○	—	○	○

△ : There are also options not contained in this catalog. Contact THK for details.

*1 SKR20/26 only use ball cages in the LM Guide component. The Ball Screw unit is equipped with the QZ Lubricator as standard.

QZ Lubricator

● For detailed dimensions, see [A2-65 to A2-75](#) and [A2-193 to A2-203](#).

The QZ Lubricator for SKR feeds the proper amount of lubricant to the outer rail and ball screw shaft raceway. This allows an oil film to be constantly formed between the balls and the raceway and significantly extends the lubrication maintenance interval.

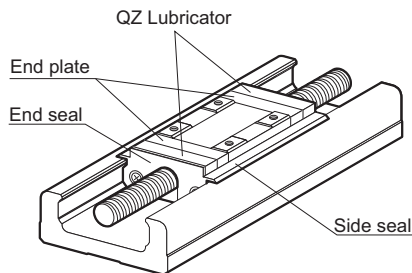

Appearance Drawing

Cover

● For the dimensions of models SKR and KR with covers attached, see [A Product Descriptions](#).

For models SKR and KR, covers are available as an option.

[\[Example of Installation\]](#)

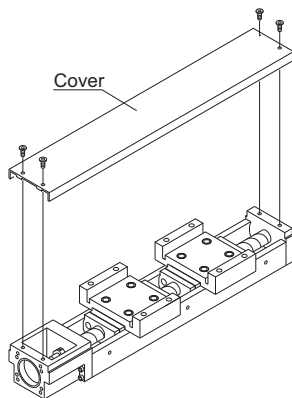

Model SKR33 (with a Cover)

Bellows

● For dimensions of the bellows, see [A2-76 to A2-80](#) and [A2-204 to A2-209](#).

For models SKR and KR, bellows are available for contamination protection in addition to a cover.

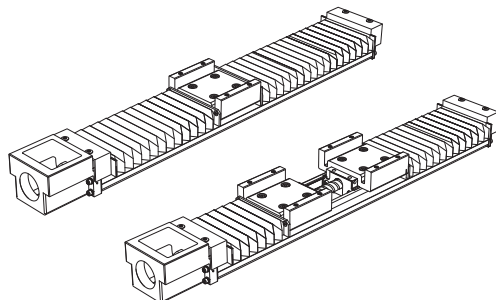

Sensor

● For detailed dimensions, see [A2-81 to A2-84](#) and [A2-210 to A2-213](#).

Optional proximity and photo sensors are available for models SKR and KR.

[Installed Example]

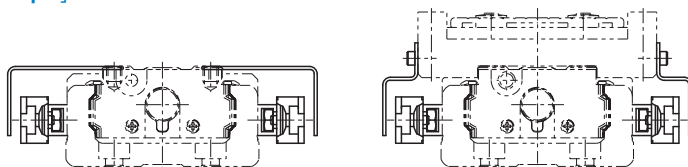

XY Bracket (for Reference)

Brackets for installing models SKR33/46 and models KR33/46 are available. The brackets use aluminum to reduce the weights and keep the inertia as low as possible.

Model No.

LM Guide Actuator

Model No.	Ball screw lead	Inner block type	QZ specification	Stroke	Accuracy grade
SKR33	10	A	QZ	0270	P
①	②	③	④	⑤	⑥
SKR20	01: 1 mm	A	No symbol : No QZ	0020: 20 mm	No symbol: Normal grade
SKR26	02: 2 mm	B	QZ	0025: 25 mm	H: High accuracy grade
SKR33	06: 6 mm	C	QZA	}	P: Precision grade
SKR46	10: 10 mm	D	QZB	1490: 1490 mm	
SKR55	20: 20 mm		QZAD		
SKR65	25: 25 mm				

SKR20	01: 1 mm
SKR26	02: 2 mm
SKR33	06: 6 mm
SKR46	10: 10 mm
SKR55	20: 20 mm
SKR65	25: 25 mm
	30: 30 mm
KR15	40: 40 mm
KR20	50: 50 mm
KR26	
KR30H	
KR33	
KR45H	
KR46	
KR55	
KR65	

QZ specification ④ can be selected on the following models.

SKR33 (→ **A2-38**)

SKR46 (→ **A2-46**)

KR33 (→ **A2-158**)

KR46 (→ **A2-174**)

KR55 (→ **A2-182**)

KR65 (→ **A2-188**)

*It cannot be selected for SKR20, SKR26, SKR55, SKR65, KR15, KR20, KR26, KR30H and KR45H.

If QZ, QZA, QZB, or QZAD is selected for QZ specification ④, specify a stroke incorporating QZ.

(→ **A2-65**, **A2-193**)

If "2: with a bellows" has been selected for Cover ⑧, specify a stroke incorporating the bellows.

(→ **A2-76**, **A2-204**)

The available ball screw leads differ depending on the model.

SKR20: "01," "06"

SKR26: "02," "06"

SKR33: "06," "10," "20" (20 mm available for inner block A and B only)

SKR46: "10," "20"

SKR55: "20," "30," "40"

SKR65: "20," "25," "30," "50"

KR15: "01," "02"

KR20: "01," "06"

KR26: "02," "06"

KR30H: "06," "10"

KR33: "06," "10"

KR45H: "10," "20"

KR46: "10," "20"

KR55: "20"

KR65: "25"

	With/without a motor		Cover	Sensor	Housing A/ Intermediate flange
	0	-	1	B	AQ
	⑦		⑧	⑨	⑩

With direct coupling
0: Direct coupling (without motor)
1: Direct coupling (THK will purchase and mount the motor you specify)
With motor wrap
R1: Non-standard side wrap (without motor)
R2: Standard side wrap (without motor)
R3: Bottom side wrap (without motor)
R4: Non-standard side wrap (THK will purchase and mount the motor you specify)
R5: Standard side wrap (THK will purchase and mount the motor you specify)
R6: Bottom side wrap (THK will purchase and mount the motor you specify)

0: Without cover
1: With cover
2: With bellows

0: None
1
2
6
7
B
E
H
L
J
M

With direct coupling	With motor wrap
A0	WN-05D
AN	WP-08D
AP	WP-08K
AQ	WP-08M
AR	WQ-08D
AS	WQ-08K
AT	WQ-08M
AU	WV-14M
AV	WY-11M
AY	WY-14M
AZ	WZ-16M
A5	WZ-19M
A6	W5-19M
10	
20	
30	
40	
60	

If QZ specification ④ "QZ," "QZA," "QZB," or "QZAD" is selected, "2: With bellows" cannot be selected.

10, 30, and 40 are only available for the KR.

If "0" is selected:

No coupling will be attached. Please specify if a coupling is required when ordering.

If "R1," "R2," or "R3" is selected:

A timing pulley and timing belt will be included.

If "1," "R4," "R5," or "R6" is selected:

The designated motor will be mounted. Please specify the motor cable direction separately.

Please select an option for ⑩ Housing A/Intermediate flange that matches the specified motor.

This product is compatible with motors from various manufacturers. Contact THK for details.

⑦ Motor wrap direction

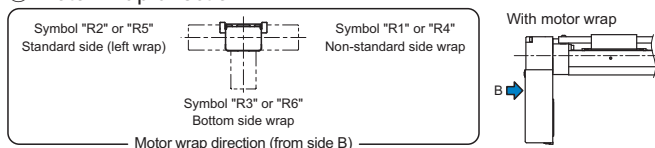

[Handling]

- (1) Do not disassemble the parts. This will result in loss of functionality.
- (2) Take care not to drop or strike the parts. Doing so may cause injury or damage. Striking it could also cause damage to its function even if the product looks intact.
- (3) When handling the product, wear protective gloves, safety shoes, etc. as necessary to ensure safety.

[Precautions on Use]

- (1) Prevent foreign material, such as cutting chips or coolant, from entering the product. Failure to do so may cause damage.
- (2) If the product is used in an environment where cutting chips, coolant, corrosive solvents, water, etc. may enter the product, use bellows, covers, etc. to prevent them from entering the product.
- (3) If foreign material such as cutting chips adheres to the product, replenish the lubricant after cleaning the product.
- (4) The service temperature range of this product is 0 to 40°C (no freezing or condensation). If you consider using this product outside the service temperature range, contact THK.
- (5) Exceeding the critical velocity may lead the components to be damaged or cause an accident. Be sure to use the product within the specification range designated by THK.
- (6) Very small strokes can inhibit the formation of an oil film between the raceways and the area of contact for the rolling elements, resulting in fretting. Therefore, be sure to use a type of grease with high fretting resistance properties if the stroke will be small. It is also recommended that a stroke movement corresponding to the length of the nut block be made on a regular basis to make sure an oil film is formed between the raceway and rolling element.
- (7) Do not use undue force when inserting parts (a pin, key, etc.) into the product. This may permanently deform the raceway, leading to loss of functionality.
- (8) If the product is operating or in the ready state, do not touch any moving parts. In addition, do not enter the operating area of the actuator.
- (9) If performing a task involving multiple people, confirm how to perform the work, what signals will be used, and how to handle problems before beginning, and assign another person to monitor the work.
- (10) Insufficient rigidity or accuracy of mounting members causes the bearing load to concentrate on one point, and the bearing performance will drop significantly. Accordingly, give sufficient consideration to the rigidity/accuracy of the housing and base and strength of the fixing bolts.
- (11) In applications where this product will be moved or transferred, the conditions of use may cause inertia from the motor's mass to result in damage to the motor attachment (Housing A) or other parts. Please contact THK before using in this manner.

[Lubrication]

- (1) Thoroughly wipe off the anti-rust oil before using the product.
- (2) Lubrication is needed to let the models SKR/KR demonstrate their functions fully. Using the product without sufficient lubrication may increase wear of the rolling elements or shorten the service life. Note the standard grease used in the product as follows.

Model KR15	THK AFF Grease
Models SKR20, SKR26, KR20, KR26	THK AFA Grease
Models SKR33, SKR46, SKR55, SKR65, KR30H, KR33, KR45H, KR46, KR55, KR65	THK AFB-LF Grease

- (3) Do not mix different lubricants. Mixing greases using the same type of thickening agent may still cause adverse interaction between the two greases if they use different additives, etc.
- (4) When using the product in locations exposed to constant vibrations or in special environments such as clean rooms, vacuum and low/high temperatures, use the grease appropriate for the specification/environment.
- (5) When adopting oil lubrication method, contact THK.
- (6) Because the intervals between greasing vary depending on the conditions of product use, it is recommended that the greasing interval be determined through an initial inspection. Although the lubrication interval may vary according to use conditions and the service environment, lubrication should be performed approximately every 100 km in travel distance (three to six months). Set the final lubrication interval/amount based on the actual machine.
- (7) The consistency of grease changes according to the temperature. Take note that the slide resistance of the models SKR/KR also changes as the consistency of grease changes.
- (8) After lubrication, the slide resistance of the models SKR/KR may increase due to the agitation resistance of grease. Be sure to perform a break-in operation to let the grease spread fully before operating the machine.
- (9) Excess grease may spatter immediately after lubrication, so wipe off spattered grease as necessary.
- (10) The properties of grease deteriorate and its lubrication performance drops over time, so grease must be checked and added properly according to the machine's frequency of use.

[Storage]

When storing the models SKR/KR, enclose them in a package designated by THK and store them in a room in a horizontal orientation while avoiding high temperatures, low temperatures, and high humidity.

After the product has been in storage for an extended period of time, the lubricant inside may have deteriorated, so add new lubricant before use.

[Disposal]

Dispose of the product properly as industrial waste.

[Instruction Manual]

You can download the "LM Guide Actuator Models SKR/KR -- Instruction Manual" from the THK technical support website.

Technical support website: <https://tech.thk.com/>

