



Spherical Plain Bearing

THK General Catalog

A Product Descriptions

Features and Types	A21-2
Features of the Spherical Plain Bearing ..	A21-2
• Structure and Features	A21-2
Types of the Spherical Plain Bearing..	A21-3
• Types and Features	A21-3
Point of Selection	A21-4
Selecting a Spherical Plain Bearing ..	A21-4
Accuracy Standards	A21-7
Radial Clearance	A21-7
Dimensional Drawing, Dimensional Table	
Model SB	A21-8
Model SA1	A21-10
Point of Design	A21-12
Fit	A21-12
Permissible Tilt Angles	A21-13
Model No.	A21-14
• Model Number Coding	A21-14
Precautions on Use	A21-15

B Support Book (Separate)

Features and Types	B21-2
Features of the Spherical Plain Bearing ..	B21-2
• Structure and Features	B21-2
Types of the Spherical Plain Bearing..	B21-3
• Types and Features	B21-3
Point of Selection	B21-4
Selecting a Spherical Plain Bearing ..	B21-4
• Example of Calculating a pV Value	B21-6
Mounting Procedure and Maintenance..	B21-7
Installation	B21-7
Lubrication	B21-7
Contamination Protection	B21-8
Model No.	B21-9
• Model Number Coding	B21-9
Precautions on Use	B21-10

Features of the Spherical Plain Bearing

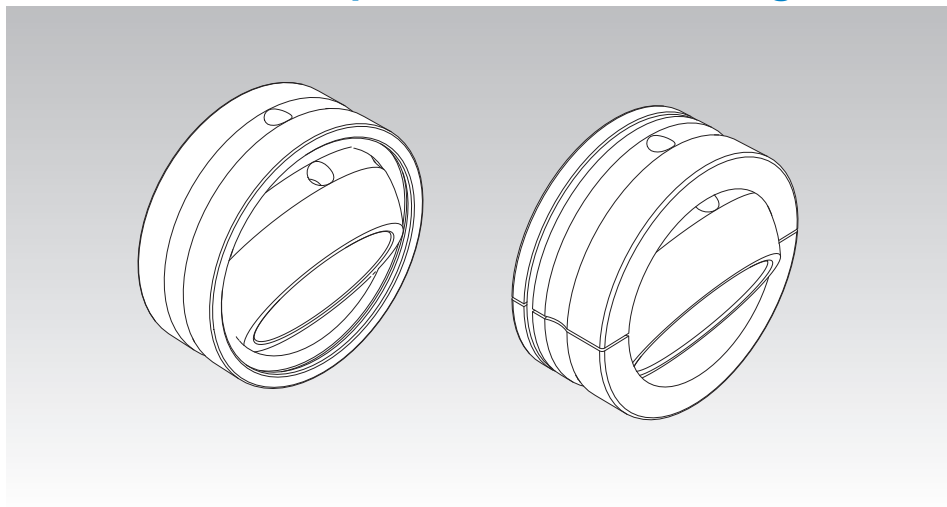

Structure and Features

Spherical Bearings models SB and SA1 are self-aligning plain bearings designed for heavy loads. The inner and outer rings of these models use high-carbon chromium bearing steel that is hardened and ground, are treated with phosphate coating, which is highly resistant to corrosion and wear, and seized with molybdenum disulfide (MoS_2).

The spherical plain bearing is capable of receiving a large radial load and thrust loads in both directions. Furthermore, because of its high resistance to impact loads, the spherical plain bearing is optimal for low-speed, heavy-load rocking components such as the cylinder clevises or hinges of civil-engineering and construction machinery and the suspensions of trucks.

Types of the Spherical Plain Bearing

Types and Features

Model SB

The most popular type of Spherical Plain Bearing in Japan, model SB has wide spherical contact areas and is used as a bearing for heavy loads. The outer ring is split at two points, enabling the inner ring to be accommodated.

Specification Table⇒ **A**21-8

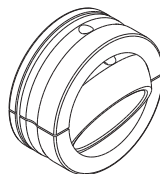

Model SB

Model SA1

This type of Spherical Plain Bearing is widely used in Europe. The outer ring is split at one point (outer rings with diameter of $\phi 100$ or thicker are split at two points), and the width and thickness are smaller than model SB. Thus, this model can be used in small spaces. Types attached with contamination protection seals on both ends (model SA1···UU) are also available.

Specification Table⇒ **A**21-10



Model SA1

Selecting a Spherical Plain Bearing

When selecting a Spherical Plain Bearing, follow the instructions below while referring to the basic dynamic load rating (C) and the basic static load rating (C₀) indicated in the corresponding specification table, as a measuring stick.

[Spherical Plain Bearing Service Life G]

The basic dynamic load rating (C) is used to calculate the service life when the bearing oscillates under a load.

The basic dynamic load rating is calculated based on the contact surface pressure of the spherical sliding section.

The Spherical Plain Bearing service life G is expressed in the total number of rocking motions until it becomes impossible for the bearing to perform normal operation due to the increase in the radial clearance or in the temperature of the bearing as a result of wear on the spherical sliding section.

Since the bearing service life is affected by various factors such as the material of the bearing, magnitude and direction of the load, lubrication conditions and sliding speed, the calculated value can be used as an empirical, practical value.

$$G = b_1 \cdot b_2 \cdot b_3 \cdot b_4 \cdot b_5 \frac{3}{Da \cdot \beta} \cdot \frac{C}{P} \times 10^8$$

- G : Bearing service life
(total number of rocking motions or total number of revolutions)
- C : Basic dynamic load rating (N)
- P : Equivalent radial load (N)
- b₁ : Load direction factor (see Table1)
- b₂ : Lubrication factor (see Table1)
- b₃ : Temperature factor (see Table1)
- b₄ : Dimension factor (see Fig.1)
- b₅ : Material factor (see Fig.2)
- Da : Spherical diameter (see the specification table) (mm)
- β : Oscillation half-angle (°)
(for rotary motion, β=90°)

* If Da (spherical diameter) is 40 or less, use b₄ = 1.

Table1

Type		b ₁		b ₂		b ₃		
		Load direction		Regular lubrication		Temperature °C		
		Fixed	Alternating	Not provided	Provided	-30 +80	+80 +150	+150 +180
Spherical Plain Bearing	Without seal	1	5	0.08	1	1	1	0.7
	With seal	1	5	0.08	1	1	—	—

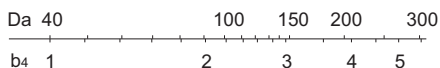

Fig.1 Dimension Factor

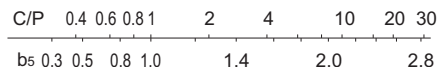

Fig.2 Material Factor

Point of Selection

Selecting a Spherical Plain Bearing

[Equivalent Radial Load]

The Spherical Plain Bearing is capable of receiving a radial load and a thrust load simultaneously. If the magnitude and direction of the load applied are constant, the equivalent radial load is obtained from the following equation.

$$P = Fr + YFa$$

- P : Equivalent radial load (N)
 Fr : Radial load (N)
 Fa : Thrust load (N)
 Y : Thrust load factor (see Table2)

Table2 Thrust Load Factor

Fa/Fr ≤	0.1	0.2	0.3	0.4	0.5
Thrust load factor (Y)	0.8	1	1.5	2.5	3

[Static Safety Factor f_s]

If the Spherical Plain Bearing is to be used under a stationary load or in slight rocking motion, select a model using the basic static load rating (C_0) as a guide. The basic static load rating refers to the stationary load that the bearing can receive without damaging the bearing and without causing permanent deformation that would prevent smooth motion.

In general, set the safety factor at three or greater taking into account the rigidity of the shaft and the housing.

$$f_s = \frac{C_0}{P} \geq 3$$

- f_s : Static safety factor
 C_0 : Basic static load rating
 P : Equivalent radial load

[pV Value]

The permissible sliding speed at which the Spherical Plain Bearing can be used varies depending on the load, lubrication conditions and cooling status. The recommended pV value for continuous motion under a load applied in a constant direction is calculated as follows.

$$pV \leq 400 \text{ N/mm}^2 \cdot \text{mm/s}$$

If the Spherical Plain Bearing performs adiabatic operation or the load direction changes, the heat produced on the sliding surface easily radiates. Therefore, it is possible to set a higher pV value. The contact surface pressure (p) of the Spherical Plain Bearing is obtained from the following equation.

$$p = \frac{P}{D_a \cdot B}$$

p	: Contact surface pressure	(N/mm ²)
P	: Equivalent radial load	(N)
D _a	: Spherical diameter (see the specification table)	(mm)
B	: Outer ring width (see the specification table)	(mm)

The sliding speed is calculated as follows.

$$V = \frac{\pi \cdot D_a \cdot \beta \cdot f}{90 \times 60}$$

V	: Sliding speed	(mm/s)
β	: Oscillation half-angle	(°)
f	: Number of rocking motions per minute	(min ⁻¹)

The spherical plain bearing can be used at sliding speeds of up to 100 mm/s in oscillating motion or up to 300 mm/s in rotary motion under favorable lubrication conditions.

Accuracy Standards

The dimensional tolerances of the Spherical Plain Bearing are defined as indicated in Table3.

Table3 Accuracy of the Spherical Plain Bearing

Unit: μm

Nominal dimension of the inner diameter (d) and outer diameter (D) (mm)		Tolerance in inner diameter (dm)		Tolerance in outer diameter (Dm)		Tolerance of the inner outer ring in width (B _i , B _o)	
Above	Or less	Upper	Lower	Upper	Lower	Upper	Lower
10	18	0	-8	—	—	0	-120
18	30	0	-10	0	-9	0	-120
30	50	0	-12	0	-11	0	-120
50	80	0	-15	0	-13	0	-150
80	120	0	-20	0	-15	0	-200
120	150	0	-25	0	-18	0	-250
150	180	0	-25	0	-25	0	-250
180	250	0	-30	0	-30	0	-300
250	315	—	—	0	-35	0	-350
315	400	—	—	0	-40	0	-400

Note1) "dm" and "Dm" represent the arithmetic averages of the maximum and minimum diameters obtained in measuring the inner and outer diameters at two points.

Note2) The dimensional tolerances of the inner and outer diameters are the values before they are surface treated.

Note3) The dimensional tolerance of the outer ring is the value before it is split.

Note4) Tolerances of the inner and outer diameters in width (B_i, B_o) are assumed to be equal, and obtained from the nominal dimension of the inner diameter of the inner ring.

Radial Clearance

Table4 shows radial clearances of the Spherical Plain Bearing.

Table4 Radial Clearances of the Spherical Plain Bearing

Unit: μm

Bearing inner diameter (d) (mm)		Radial clearance	
Above	Or less	Min.	Max.
—	17	70	125
17	30	75	140
30	50	85	150
50	65	90	160
65	80	95	170
80	100	100	185
100	120	110	200
120	150	120	215
150	240	130	230

Note1) The radial clearance indicates the value before the outer ring is split.

Note2) The axial clearance is approximately twice the radial clearance.

Model SB

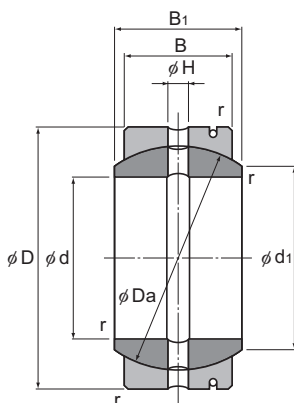

Unit: mm

Model No.	Main dimensions								Basic load rating		Mass kg
	Inner diameter d	Outer diameter D	Outer ring width B	Inner ring width B_1	d_i	D_a	H	r	C	C_0	
SB 12	12	22	9	11	14	18	1.5	0.5	3.82	95.3	0.019
SB 15	15	26	11	13	17.5	22	2.5	0.5	5.69	142	0.028
SB 20	20	32	14	16	23	28	2.5	0.5	9.22	230	0.053
SB 22	22	37	16	19	25.5	32	2.5	0.5	12.1	301	0.085
SB 25	25	42	18	21	29	36	4	0.5	15.3	381	0.116
SB 30	30	50	23	27	36	45	4	1	24.3	609	0.225
SB 35	35	55	26	30	40	50	4	1	30.6	765	0.3
SB 40	40	62	28	33	44	55	4	1	36.3	906	0.375
SB 45	45	72	31	36	50.5	62	6	1	45.2	1130	0.6
SB 50	50	80	36	42	58.5	72	6	1	61	1530	0.87
SB 55	55	90	40	47	64.5	80	6	1	75.3	1880	1.26
SB 60	60	100	45	53	72.5	90	6	1	95.3	2380	1.7
SB 65	65	105	47	55	76	94	6	1	104	2600	2.05

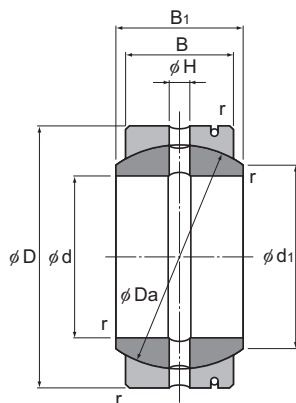

Unit: mm

Model No.	Main dimensions								Basic load rating		Mass kg
	Inner diameter d	Outer diameter D	Outer ring width B	Inner ring width B ₁	d ₁	Da	H	r	C kN	C ₀ kN	
SB 70	70	110	50	58	81.5	100	8	1	118	2940	2.22
SB 75	75	120	55	64	89.5	110	8	1	142	3560	3.02
SB 80	80	130	60	70	97.5	120	8	1	170	4240	3.98
SB 85	85	135	63	74	100.5	125	8	1	185	4640	4.29
SB 90	90	140	65	76	105.5	130	8	1	199	4970	4.71
SB 95	95	150	70	82	113.5	140	8	1	230	5760	6.05
SB 100	100	160	75	88	121.5	150	10	1.5	265	6620	7.42
SB 110	110	170	80	93	130	160	10	1.5	301	7530	8.55
SB 115	115	180	85	98	132.5	165	10	1.5	330	8250	10.3
SB 120	120	190	90	105	140	175	10	1.5	371	9260	12.4
SB 130	130	200	95	110	148.5	185	10	1.5	414	10300	13.8
SB 150	150	220	105	120	166	205	10	1.5	507	12600	17

Model SA1

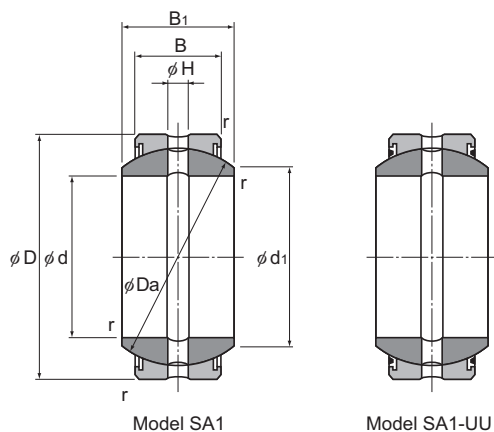

Unit: mm

Model No.		Main dimensions								Basic load rating		Mass
Standard type	Seal type	Inner diameter	Outer diameter	Outer ring width	Inner ring width					C	C ₀	kg
		d	D	B	B ₁	d ₁	Da	H	r	kN	kN	
SA1 12	SA1 12UU	12	22	7	10	15	18	1.5	0.3	2.94	74.1	0.017
SA1 15	SA1 15UU	15	26	9	12	18.4	22	2.5	0.3	4.7	117	0.032
SA1 17	SA1 17UU	17	30	10	14	20.7	25	2.5	0.3	5.88	147	0.049
SA1 20	SA1 20UU	20	35	12	16	24.2	29	2.5	0.3	8.23	205	0.065
SA1 25	SA1 25UU	25	42	16	20	29.3	35.5	4	0.3	13.3	334	0.115
SA1 30	SA1 30UU	30	47	18	22	34.2	40.7	4	0.3	17.3	431	0.16
SA1 35	SA1 35UU	35	55	20	25	39.8	47	4	1	22.1	553	0.258
SA1 40	SA1 40UU	40	62	22	28	45	53	4	1	27.5	686	0.315
SA1 45	SA1 45UU	45	68	25	32	50.8	60	6	1	35.3	882	0.413
SA1 50	SA1 50UU	50	75	28	35	56	66	6	1	43.5	1090	0.56
SA1 60	SA1 60UU	60	90	36	44	66.8	80	6	1.5	67.7	1700	1.1
SA1 70	SA1 70UU	70	105	40	49	77.9	92	8	1.5	86.6	2170	1.54

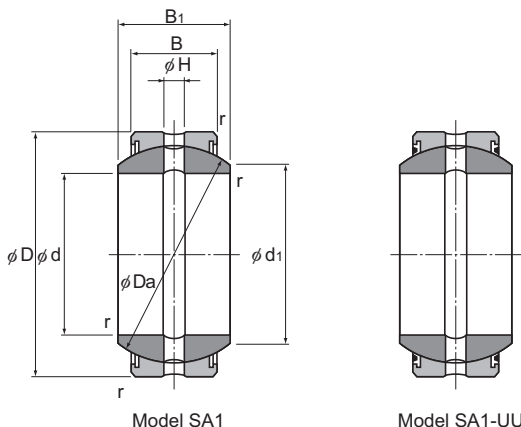

Unit: mm

Model No.		Main dimensions								Basic load rating		Mass kg
Standard type	Seal type	Inner diameter d	Outer diameter D	Outer ring width B	Inner ring width B ₁	d ₁	Da	H	r	C kN	C ₀ kN	
SA1 80	SA1 80UU	80	120	45	55	89.4	105	8	1.5	111	2780	2.29
SA1 90	SA1 90UU	90	130	50	60	98.1	115	8	2	135	3380	2.84
SA1 100	SA1 100UU	100	150	55	70	109.5	130	8	2	169	4210	4.43
SA1 110	SA1 110UU	110	160	55	70	121.2	140	8	2	181	4530	4.94
SA1 120	SA1 120UU	120	180	70	85	135.6	160	8	2	264	6590	8.12
SA1 140	SA1 140UU	140	210	70	90	155.9	180	8	3	296	7410	11.3
SA1 160	SA1 160UU	160	230	80	105	170.2	200	10	3	376	9410	14.4
SA1 180	SA1 180UU	180	260	80	105	199	225	10	3	424	10600	18.9
SA1 200	SA1 200UU	200	290	100	130	213.5	250	10	3	588	14700	28.1
SA1 220	SA1 220UU	220	320	100	135	239.6	275	10	3.5	647	16200	36.1
SA1 240	SA1 240UU	240	340	100	140	265.3	300	10	3.5	706	17600	40.4

Note) Model numbers "...100" or higher have double-slit outer rings.

Fit

The fitting between the Spherical Plain Bearing and the shaft or the housing is selected according to the conditions. Table1 shows recommended values.

Table1 Recommended Fitting Values

Service condition		Shaft	Housing
Inner ring rotational load	Normal load	k6	H7
	Indeterminate load	m6	H7
Outer ring rotational load	Normal load	g6	M7
	Indeterminate load	h6	N7

Note1) If the product is to be installed so that the inner ring rotates and the fitting with the shaft is to be clearance fitting, harden the surface of the shaft in advance.

Note2) "N7" is recommended for light alloy housings.

[Shaft Designing]

If the inner ring is to be fit onto the shaft in loose fitting and the product is to be used under a heavy load, the shaft may slip on the inner circumference of the inner ring. To prevent the slippage, the shaft hardness must be 58 HRC or higher and the surface roughness must be Ra0.80 or below.

Permissible Tilt Angles

The permissible tilt angle of the Spherical Plain Bearing varies according to the shaft shape as indicated in Table2.

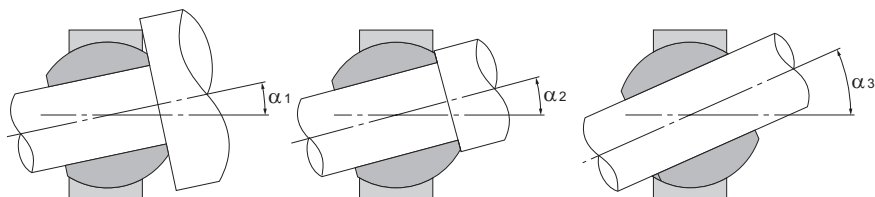

Table2 Permissible Tilt Angles

Unit: °

Unit: °

Model No.	Permissible tilt angles		
	α_1	α_2	α_3
SB 12	5	7	18
SB 15	4	6	18
SB 20	3	4	14
SB 22	4	6	16
SB 25	4	5	16
SB 30	4	6	17
SB 35	4	5	14
SB 40	4	6	12
SB 45	4	5	13
SB 50	4	5	16
SB 55	4	6	16
SB 60	4	6	18
SB 65	4	5	16
SB 70	4	5	15
SB 75	4	5	18
SB 80	4	5	18
SB 85	4	6	16
SB 90	4	5	16
SB 95	4	5	17
SB 100	4	5	18
SB 110	4	5	16
SB 115	4	5	14
SB 120	4	6	15
SB 130	4	5	14
SB 150	4	5	12

Model No.	Permissible tilt angles		
	α_1	α_2 ^{Note)}	α_3
SA1 12	8	11 (6)	25 (6)
SA1 15	6	8 (5)	18 (5)
SA1 17	7	10 (7)	23 (7)
SA1 20	6	9 (6)	21 (6)
SA1 25	6	7 (4)	18 (4)
SA1 30	4	6 (4)	16 (4)
SA1 35	5	6 (4)	16 (4)
SA1 40	5	7 (4)	16 (4)
SA1 45	6	7 (4)	16 (4)
SA1 50	5	6 (4)	15 (4)
SA1 60	5	6 (3)	14 (3)
SA1 70	5	6 (4)	14 (4)
SA1 80	4	6 (4)	14 (4)
SA1 90	4	5 (3)	12 (3)
SA1 100	5	7 (5)	14 (5)
SA1 110	5	6 (4)	15 (4)
SA1 120	4	6 (4)	15 (4)
SA1 140	5	7 (5)	16 (5)
SA1 160	6	8 (6)	13 (6)
SA1 180	5	6 (5)	16 (5)
SA1 200	6	7 (6)	13 (6)
SA1 220	6	8 (6)	15 (6)
SA1 240	6	8 (6)	17 (6)

Note) The values in the parentheses apply to types attached with a seal.

Model Number Coding

Model number configurations differ depending on the model features. Refer to the corresponding sample model number configuration.

[Spherical Plain Bearing]

- Models SB and SA1

SB25

Model No.

SA1 25 UU

Model No.

Seal
No symbol: none
UU: With

Precautions on Use

Spherical Plain Bearing

[Handling]

- (1) Do not disassemble model SA1 or SB prior to installation. Disassembling the product will result in loss of function.
- (2) Take care not to drop or strike the spherical plain bearing. Doing so may cause injury or damage. Giving an impact to it could also cause damage to its function even if the product looks intact.
- (3) When handling the product, wear protective gloves, safety shoes, etc., as necessary to ensure safety.

[Precautions on Use]

- (1) Prevent foreign material, such as cutting chips or coolant, from entering the product. Failure to do so may cause damage.
- (2) If foreign material such as cutting chips adheres to the product, replenish the lubricant after cleaning the product.
- (3) Do not use undue force when fitting parts (pin, key, etc.) to the product. This may generate permanent deformation on the raceway, leading to loss of functionality.
- (4) Insufficient rigidity or accuracy of mounting members causes the bearing load to concentrate on one point and the bearing performance will drop significantly. Accordingly, give sufficient consideration to the rigidity/accuracy of the housing and base and strength of the fixing bolts.

[Lubrication]

- (1) For details of the lubrication, see **B 21-7**.
- (2) Do not mix different lubricants. Mixing greases using the same type of thickening agent may still cause adverse interaction between the two greases if they use different additives, etc.
- (3) When using the product in locations exposed to constant vibrations or in special environments such as clean rooms, vacuum and low/high temperature, use the grease appropriate for the specification/environment.
- (4) The consistency of grease changes according to the temperature. Take note that the slide resistance of the spherical bearing also changes as the consistency of grease changes.
- (5) After lubrication, the slide resistance of the spherical bearing may increase due to the agitation resistance of grease. Be sure to perform a break-in to let the grease spread fully, before operating the machine.
- (6) Excess grease may scatter immediately after lubrication, so wipe off scattered grease as necessary.
- (7) The properties of grease deteriorate and its lubrication performance drops over time, so grease must be checked and added properly according to the use frequency of the machine.
- (8) The greasing interval varies depending on the use condition and service environment. Set the final lubrication interval/amount based on the actual machine.

[Storage]

When storing the Spherical Plain Bearing, enclose it in a package designated by THK and store it in a room while avoiding high temperature, low temperature and high humidity.

[Disposal]

Dispose of the product properly as industrial waste.



Spherical Plain Bearing

THK General Catalog

B Support Book

Features and Types	B21-2
Features of the Spherical Plain Bearing ..	B21-2
• Structure and Features	B21-2
Types of the Spherical Plain Bearing..	B21-3
• Types and Features	B21-3
Point of Selection	B21-4
Selecting a Spherical Plain Bearing ..	B21-4
• Example of Calculating a pV Value	B21-6
Mounting Procedure and Maintenance ..	B21-7
Installation	B21-7
Lubrication	B21-7
Contamination Protection	B21-8
Model No.	B21-9
• Model Number Coding	B21-9
Precautions on Use	B21-10

A Product Descriptions (Separate)

Features and Types	A21-2
Features of the Spherical Plain Bearing ..	A21-2
• Structure and Features	A21-2
Types of the Spherical Plain Bearing..	A21-3
• Types and Features	A21-3
Point of Selection	A21-4
Selecting a Spherical Plain Bearing ..	A21-4
Accuracy Standards	A21-7
Radial Clearance	A21-7
Dimensional Drawing, Dimensional Table	
Model SB	A21-8
Model SA1	A21-10
Point of Design	A21-12
Fit	A21-12
Permissible Tilt Angles	A21-13
Model No.	A21-14
• Model Number Coding	A21-14
Precautions on Use	A21-15

Features of the Spherical Plain Bearing

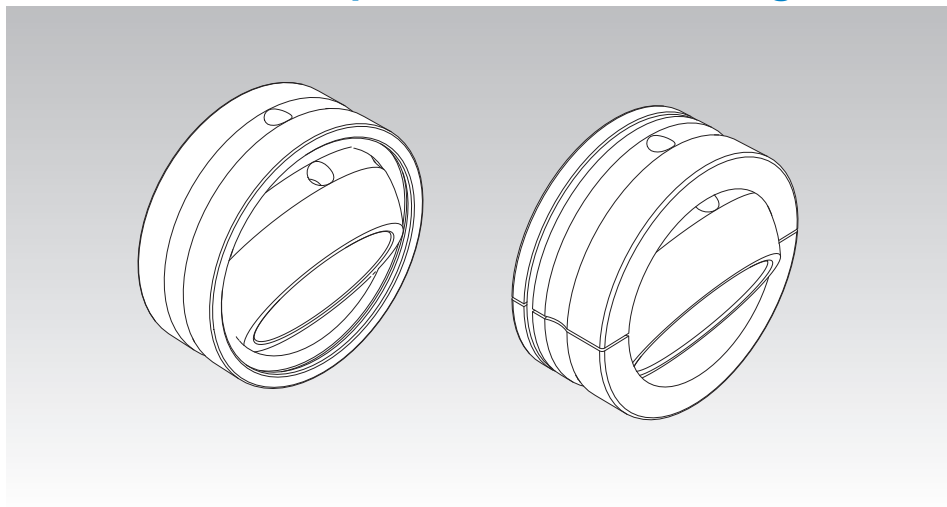

Structure and Features

Spherical Bearings models SB and SA1 are self-aligning plain bearings designed for heavy loads. The inner and outer rings of these models use high-carbon chromium bearing steel that is hardened and ground, are treated with phosphate coating, which is highly resistant to corrosion and wear, and seized with molybdenum disulfide (MoS_2).

The spherical plain bearing is capable of receiving a large radial load and thrust loads in both directions. Furthermore, because of its high resistance to impact loads, the spherical plain bearing is optimal for low-speed, heavy-load rocking components such as the cylinder clevises or hinges of civil-engineering and construction machinery and the suspensions of trucks.

Types of the Spherical Plain Bearing

Types and Features

Model SB

The most popular type of Spherical Plain Bearing in Japan, model SB has wide spherical contact areas and is used as a bearing for heavy loads. The outer ring is split at two points, enabling the inner ring to be accommodated.

Specification Table⇒ **A** 21-8

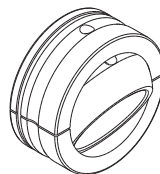

Model SB

Model SA1

This type of Spherical Plain Bearing is widely used in Europe. The outer ring is split at one point (outer rings with diameter of $\phi 100$ or thicker are split at two points), and the width and thickness are smaller than model SB. Thus, this model can be used in small spaces. Types attached with contamination protection seals on both ends (model SA1···UU) are also available.

Specification Table⇒ **A** 21-10



Model SA1

Selecting a Spherical Plain Bearing

When selecting a Spherical Plain Bearing, follow the instructions below while referring to the basic dynamic load rating (C) and the basic static load rating (C₀) indicated in the corresponding specification table, as a measuring stick.

[Spherical Plain Bearing Service Life G]

The basic dynamic load rating (C) is used to calculate the service life when the bearing oscillates under a load.

The basic dynamic load rating is calculated based on the contact surface pressure of the spherical sliding section.

The Spherical Plain Bearing service life G is expressed in the total number of rocking motions until it becomes impossible for the bearing to perform normal operation due to the increase in the radial clearance or in the temperature of the bearing as a result of wear on the spherical sliding section.

Since the bearing service life is affected by various factors such as the material of the bearing, magnitude and direction of the load, lubrication conditions and sliding speed, the calculated value can be used as an empirical, practical value.

$$G = b_1 \cdot b_2 \cdot b_3 \cdot b_4 \cdot b_5 \frac{3}{Da \cdot \beta} \cdot \frac{C}{P} \times 10^8$$

- G : Bearing service life
(total number of rocking motions or total number of revolutions)
- C : Basic dynamic load rating (N)
- P : Equivalent radial load (N)
- b₁ : Load direction factor (see Table1)
- b₂ : Lubrication factor (see Table1)
- b₃ : Temperature factor (see Table1)
- b₄ : Dimension factor (see Fig.1)
- b₅ : Material factor (see Fig.2)
- Da : Spherical diameter (see the specification table) (mm)
- β : Oscillation half-angle (°)
(for rotary motion, β=90°)

* If Da (spherical diameter) is 40 or less, use b₄ = 1.

Table1

Type		b ₁		b ₂		b ₃		
		Load direction		Regular lubrication		Temperature °C		
		Fixed	Alternating	Not provided	Provided	-30 +80	+80 +150	+150 +180
Spherical Plain Bearing	Without seal	1	5	0.08	1	1	1	0.7
	With seal	1	5	0.08	1	1	—	—

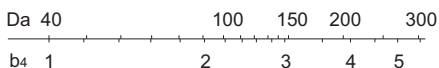

Fig.1 Dimension Factor

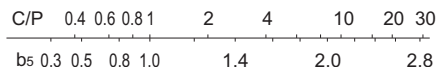

Fig.2 Material Factor

Point of Selection

Selecting a Spherical Plain Bearing

[Equivalent Radial Load]

The Spherical Plain Bearing is capable of receiving a radial load and a thrust load simultaneously. If the magnitude and direction of the load applied are constant, the equivalent radial load is obtained from the following equation.

$$P = Fr + YFa$$

- P : Equivalent radial load (N)
 Fr : Radial load (N)
 Fa : Thrust load (N)
 Y : Thrust load factor (see Table2)

Table2 Thrust Load Factor

Fa/Fr ≤	0.1	0.2	0.3	0.4	0.5
Thrust load factor (Y)	0.8	1	1.5	2.5	3

[Static Safety Factor f_s]

If the Spherical Plain Bearing is to be used under a stationary load or in slight rocking motion, select a model using the basic static load rating (C_0) as a guide. The basic static load rating refers to the stationary load that the bearing can receive without damaging the bearing and without causing permanent deformation that would prevent smooth motion.

In general, set the safety factor at three or greater taking into account the rigidity of the shaft and the housing.

$$f_s = \frac{C_0}{P} \geq 3$$

- f_s : Static safety factor
 C_0 : Basic static load rating
 P : Equivalent radial load

[pV Value]

The permissible sliding speed at which the Spherical Plain Bearing can be used varies depending on the load, lubrication conditions and cooling status. The recommended pV value for continuous motion under a load applied in a constant direction is calculated as follows.

$$pV \leq 400 \text{ N/mm}^2 \cdot \text{mm/s}$$

If the Spherical Plain Bearing performs adiabatic operation or the load direction changes, the heat produced on the sliding surface easily radiates. Therefore, it is possible to set a higher pV value. The contact surface pressure (p) of the Spherical Plain Bearing is obtained from the following equation.

$$p = \frac{P}{Da \cdot B}$$

- p : Contact surface pressure (N/mm²)
 P : Equivalent radial load (N)
 Da : Spherical diameter (see the specification table) (mm)
 B : Outer ring width (see the specification table) (mm)

The sliding speed is calculated as follows.

$$V = \frac{\pi \cdot Da \cdot \beta \cdot f}{90 \times 60}$$

- V : Sliding speed (mm/s)
 β : Oscillation half-angle (°)
 f : Number of rocking motions per minute (min⁻¹)

The spherical plain bearing can be used at sliding speeds of up to 100 mm/s in oscillating motion or up to 300 mm/s in rotary motion under favorable lubrication conditions.

Example of Calculating a pV Value

Assuming that model SB25 is used in a location where the shaft rotates 60 turns per minute at an angle of 40°(oscillation half angle : 20°) and the maximum varying load of 1,500 N is applied, determine whether the model number is appropriate and calculate the service life under these conditions. Assume that the bearing temperature is +80°C or less and the product is regularly provided with sufficient lubrication. Calculate the pV value and examine if the bearing size is appropriate.

The contact surface pressure (p) is calculated as follows.

$$p = \frac{P}{Da \cdot B} = \frac{1500}{36 \times 18} = 2.31 \text{ N/mm}^2 \quad \left(\begin{array}{l} B: \text{outer ring width of model SB25} = 18 \\ Da: \text{spherical diameter of model SB25} = 36 \end{array} \right)$$

The sliding speed (V) is obtained from the following equation.

$$V = \frac{\pi \cdot Da \cdot \beta \cdot f}{90 \times 60} = \frac{3.14 \times 36 \times \left(\frac{40}{2}\right) \times 60}{90 \times 60} = 25.12 \text{ mm/s}$$

The pV value is calculated as follows.

$$pV = 58.0 \text{ N/mm}^2 \cdot \text{mm/s}$$

Since both the pV value and the sliding speed (V) meet the requirements, model SB25 can be used.

Next, calculate the service life of the bearing (G) as follows.

$$G = b_1 \cdot b_2 \cdot b_3 \cdot b_4 \cdot b_5 \cdot \frac{3}{Da \cdot \beta} \cdot \frac{C}{P} \times 10^8$$

$$= 5 \times 1 \times 1 \times 1 \times 2.2 \times \frac{3}{36 \times 20} \times \frac{15300}{1500} \times 10^8 = 4.7 \times 10^7 \text{ (min}^{-1}\text{)}$$

Installation

- (1) Do not use the product in the manner that the permissible tilting angle is exceeded since doing so may damage the product.
- (2) The Spherical Plain Bearing is designed for use under a radial load. Do not use the product if the trust load component or the load component in the thrust direction exceeds 50% of the resultant force consisting of the radial load and the thrust load.
- (3) When installing the Spherical Plain Bearing, pay attention to the mounting orientation so that the slit of the outer ring receives a minimum load.

[Temperature Range]

The permissible temperature range of the Spherical Plain Bearing is limited between -30°C and 80°C depending on the seal material and determined by the permissible temperature range of the grease used.

Lubrication

The spherical sliding surface of the Spherical Plain Bearing is seized with a solid lubricant film of molybdenum disulfide. This enables the Spherical Plain Bearing to be used over a relatively long period without further lubrication under a static load, in low-speed rocking motion or in intermittent rotary motion. However, it is generally necessary to replenish grease on a regular basis. If a heavy load is applied, consider using lithium soap group grease containing molybdenum disulfide. The inner and outer rings of the Spherical Plain Bearing have greasing holes as a means to facilitate the flow of the lubricant inside the bearing.

[Lubrication Interval]

Since the Spherical Plain Bearing is delivered without being applied with a lubricant, it is necessary to replenish an appropriate amount of grease after installing the Spherical Plain Bearing. We recommend filling grease also to the space surrounding the Spherical Plain Bearing. It is also recommendable to shorten the lubrication interval in the start-up period in order to lighten the initial wear and extend the service life.

The lubrication interval varies according to the magnitude of the load, frequency of the vibrations and other conditions. Provide lubrication while referring to the values in Table1 as a guide.

Table1 Lubrication Interval

Type of load	Required minimum lubrication interval
Unilateral load	G/ 40
Fluctuating load	G/ 180

G: Service life of the bearing (total number of rocking motions or total number of revolutions)

Contamination Protection

Spherical Bearing model SA1 is provided with a seal designed to prevent humidity or other contaminants from entering the bearing. This seal is effective in increasing the service life of the bearing. The seal for Spherical Bearing model SA1 is made of oil-resistant synthetic rubber and has double lips as the sealing element. These lips closely contact the spherical inner ring. The seal can be used within the temperature range between -30°C and 80°C , and is highly resistant to wear and capable of operating for a long period of time. If the product is used in an environment where sand or soil matter may enter the bearing, the service life of the seal is shortened. We recommend lubricating the product on a regular basis.

Model Number Coding

Model number configurations differ depending on the model features. Refer to the corresponding sample model number configuration.

[Spherical Plain Bearing]

● Models SB and SA1

SB25

Model No.

SA1 25 UU

Model No.

Seal
No symbol: none
UU: With

Precautions on Use

Spherical Plain Bearing

[Handling]

- (1) Do not disassemble model SA1 or SB prior to installation. Disassembling the product will result in loss of function.
- (2) Take care not to drop or strike the spherical plain bearing. Doing so may cause injury or damage. Giving an impact to it could also cause damage to its function even if the product looks intact.
- (3) When handling the product, wear protective gloves, safety shoes, etc., as necessary to ensure safety.

[Precautions on Use]

- (1) Prevent foreign material, such as cutting chips or coolant, from entering the product. Failure to do so may cause damage.
- (2) If foreign material such as cutting chips adheres to the product, replenish the lubricant after cleaning the product.
- (3) Do not use undue force when fitting parts (pin, key, etc.) to the product. This may generate permanent deformation on the raceway, leading to loss of functionality.
- (4) Insufficient rigidity or accuracy of mounting members causes the bearing load to concentrate on one point and the bearing performance will drop significantly. Accordingly, give sufficient consideration to the rigidity/accuracy of the housing and base and strength of the fixing bolts.

[Lubrication]

- (1) For details of the lubrication, see **B21-7**.
- (2) Do not mix different lubricants. Mixing greases using the same type of thickening agent may still cause adverse interaction between the two greases if they use different additives, etc.
- (3) When using the product in locations exposed to constant vibrations or in special environments such as clean rooms, vacuum and low/high temperature, use the grease appropriate for the specification/environment.
- (4) The consistency of grease changes according to the temperature. Take note that the slide resistance of the spherical bearing also changes as the consistency of grease changes.
- (5) After lubrication, the slide resistance of the spherical bearing may increase due to the agitation resistance of grease. Be sure to perform a break-in to let the grease spread fully, before operating the machine.
- (6) Excess grease may scatter immediately after lubrication, so wipe off scattered grease as necessary.
- (7) The properties of grease deteriorate and its lubrication performance drops over time, so grease must be checked and added properly according to the use frequency of the machine.
- (8) The greasing interval varies depending on the use condition and service environment. Set the final lubrication interval/amount based on the actual machine.

[Storage]

When storing the Spherical Plain Bearing, enclose it in a package designated by THK and store it in a room while avoiding high temperature, low temperature and high humidity.

[Disposal]

Dispose of the product properly as industrial waste.